



**THE DATASHEET OF
LTC4307CMS8-1#TRPBF**



High Definition Multimedia Interface (HDMI) Level-Shifting 2-Wire Bus Buffer

FEATURES

- Bidirectional Buffer for Display Data Channel (DDC)
- Compliant with HDMI Specification Version 1.3 DDC Capacitance Requirement
- Level Translation Between 3.3V and 5V
- $\pm 5\text{kV}$ Human Body Model ESD Protection
- 60mV Buffer Offset Independent of Load
- Compatible with Non-Compliant V_{OL} I²C Devices
- Isolates Input SDA and SCL Line from Output
- Compatible with I²C™, I²C Fast Mode and SMBus
- READY Open-Drain Output
- High Impedance SDA, SCL Pins for $V_{CC} = 0\text{V}$
- Small 8-Lead (3mm × 3mm) DFN and 8-Lead MSOP Packages

APPLICATIONS

- HDMI
- 3.3V/5V Level Translation
- Capacitance Buffer/Bus Extender

DESCRIPTION

The LTC4307-1 is a 2-wire bus buffer that provides capacitance buffering between input and output. The HDMI specification requires that devices have less than 50pF of input capacitance on their DDC bus lines. The LTC4307-1's capacitance buffering feature, in conjunction with its sub-10pF data and clock input capacitance, allows HDMI components to easily meet the 50pF requirement and tolerate high capacitance on the internal bus.

The LTC4307-1 also provides level-shifting between 3.3V and 5V systems to allow lower voltage HDMI transmitters, receivers and EEPROM to interface to the 5V DDC bus. READY is an open-drain digital output flag that indicates whether or not the input and output busses are connected and can interface to the HDMI hot plug detect (HPD) signal. When driven high, the ENABLE digital input allows the LTC4307-1 to connect after a stop bit or bus idle. Driving ENABLE low breaks the connection between the input and output busses.

LT, *LT*, *LTC* and *LTM* are registered trademarks of Linear Technology Corporation. All other trademarks are the property of their respective owners. Protected by U.S. Patents, including 7032051, 6356140, 6650174

TYPICAL APPLICATION

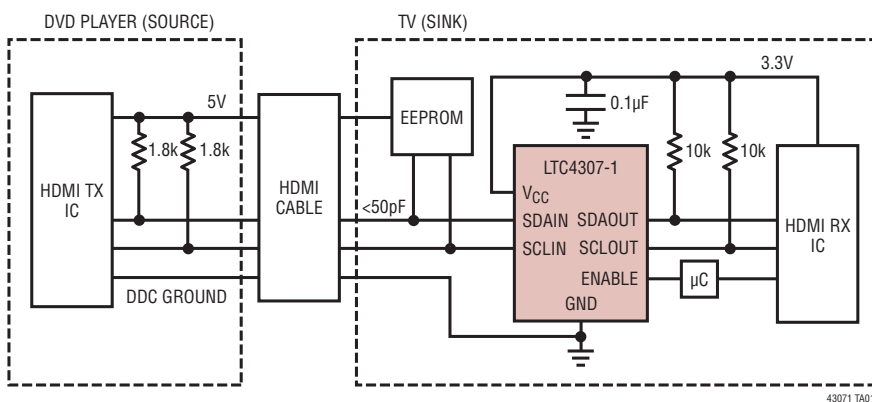

Rising Edge from Asserted Low

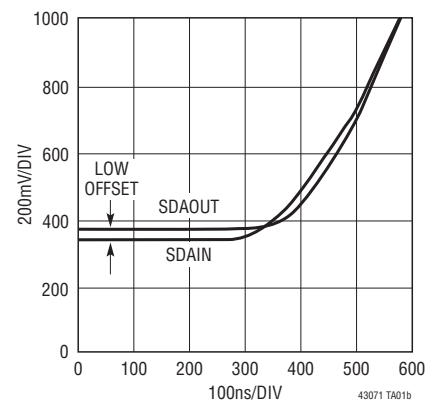

LTC4307-1

ABSOLUTE MAXIMUM RATINGS (Notes 1, 6)

V_{CC} to GND	-0.3V to 6V	Storage Temperature Range	
SDAIN, SCLIN, SDAOUT, SCLOUT, READY, ENABLE	-0.3V to 6V	DFN	-65°C to 125°C
Maximum Sink Current (SDAIN, SCLIN, SDAOUT, SCLOUT, READY)	50mA	MSOP	-65°C to 150°C
Operating Temperature Range		Lead Temperature (Soldering, 10 sec)	
LTC4307C	0°C to 70°C	MSOP	300°C
LTC4307I	-40°C to 85°C		

PIN CONFIGURATION

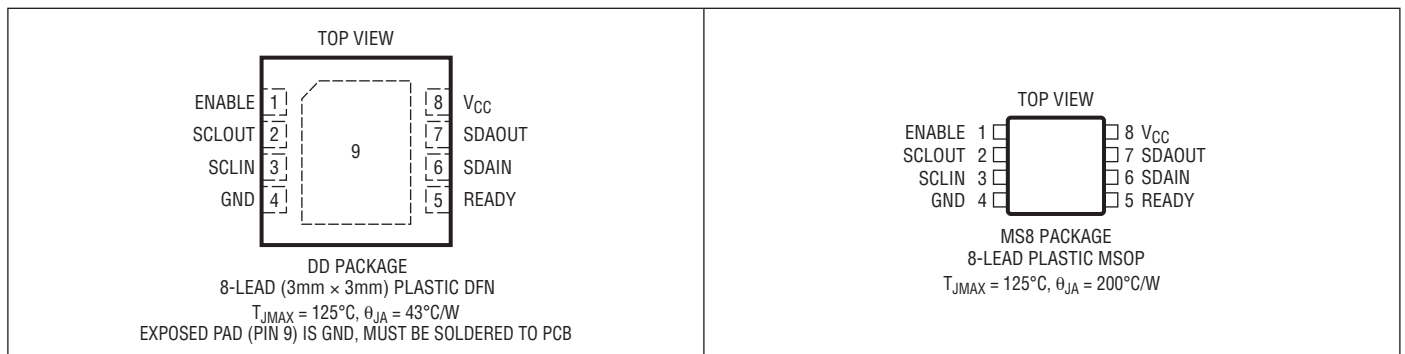

ORDER INFORMATION

LEAD FREE FINISH	TAPE AND REEL	PART MARKING*	PACKAGE DESCRIPTION	TEMPERATURE RANGE
LTC4307CDD-1#PBF	LTC4307CDD-1#TRPBF	LDBP	8-Lead (3mm × 3mm) Plastic DFN	0°C to 70°C
LTC4307IDD-1#PBF	LTC4307IDD-1#TRPBF	LDBP	8-Lead (3mm × 3mm) Plastic DFN	-40°C to 85°C
LTC4307CMS8-1#PBF	LTC4307CMS8-1#TRPBF	LTDBN	8-Lead Plastic MSOP	0°C to 70°C
LTC4307IMS8-1#PBF	LTC4307IMS8-1#TRPBF	LTDBN	8-Lead Plastic MSOP	-40°C to 85°C

Consult LTC Marketing for parts specified with wider operating temperature ranges. *The temperature grade is identified by a label on the shipping container.

For more information on lead free part marking, go to: <http://www.linear.com/leadfree/>

For more information on tape and reel specifications, go to: <http://www.linear.com/tapeandreeel/>

ELECTRICAL CHARACTERISTICS

The ● denotes the specifications which apply over the full operating temperature range, otherwise specifications are at $T_A = 25^\circ\text{C}$. $V_{CC} = 3.3\text{V}$, unless otherwise noted.

SYMBOL	PARAMETER	CONDITIONS	MIN	TYP	MAX	UNITS
Power Supply						
V_{CC}	Positive Supply Voltage		● 2.3		5.5	V
I_{CC}	Supply Current	$V_{CC} = 5.5\text{V}$, $V_{SCLOUT} = V_{SDAOUT} = 0\text{V}$ (Note 5)	●	8	11	mA
I_{SD}	Shutdown Supply Current	$V_{CC} = 5.5\text{V}$, ENABLE = GND, SDA, SCL = 5.5V	●	900	1200	μA
t_{IDLE}	Bus Idle Time		●	55	95	μs

ELECTRICAL CHARACTERISTICS

The ● denotes the specifications which apply over the full operating temperature range, otherwise specifications are at $T_A = 25^\circ\text{C}$. $V_{CC} = 3.3\text{V}$, unless otherwise noted.

SYMBOL	PARAMETER	CONDITIONS	MIN	TYP	MAX	UNITS	
V_{THR_ENABLE}	ENABLE Threshold		0.8	1.4	2	V	
I_{ENABLE}	ENABLE Input Current	ENABLE from 0V to V_{CC}	●	0.1	±5	μA	
t_{PLH_EN}	ENABLE Delay Off-On	$V_{CC} = 3.3\text{V}$ (Figure 1)		95		μs	
t_{PHL_EN}	ENABLE Delay On-Off	$V_{CC} = 3.3\text{V}$ (Note 3) (Figure 1)		10		ns	
t_{PLH_READY}	READY Delay Off-On	$V_{CC} = 3.3\text{V}$ (Note 3) (Figure 1)		10		ns	
t_{PHL_READY}	READY Delay On-Off	$V_{CC} = 3.3\text{V}$ (Note 3) (Figure 1)		10		ns	
V_{OL_READY}	READY Output Low Voltage	$I_{PULLUP} = 3\text{mA}$, $V_{CC} = 2.3\text{V}$	●		0.4	V	
I_{OFF_READY}	READY Off Leakage Current	$V_{CC} = \text{READY} = 5.5\text{V}$	●	0.1	±5	μA	
Propagation Delay							
t_{PHL}	SDA/SCL Propagation Delay High to Low	$C_{LOAD} = 50\text{pF}$, 2.7k to V_{CC} on SDA, SCL, $V_{CC} = 3.3\text{V}$ (Notes 2, 3) (Figure 1)		70		ns	
t_{PLH}	SDA/SCL Propagation Delay Low to High	$C_{LOAD} = 50\text{pF}$, 2.7k to V_{CC} on SDA, SCL, $V_{CC} = 3.3\text{V}$ (Notes 2, 3) (Figure 1)		10		ns	
t_{FALL}	SDA/SCL Transition Time High to Low	$C_{LOAD} = 100\text{pF}$, 10k to V_{CC} on SDA, SCL, $V_{CC} = 3.3\text{V}$ (Notes 3, 4) (Figure 1)		30	300	ns	
Input-Output Connection							
V_{OS}	Input-Output Offset Voltage	2.7k to V_{CC} on SDA, SCL, $V_{CC} = 3.3\text{V}$, Driven SDA, SCL = 0.2V	●	20	60	100	mV
V_{THR}	SDA, SCL Logic Input Threshold Voltage	Rising Edge		$0.45V_{CC}$	$0.55V_{CC}$	$0.65V_{CC}$	V
V_{HYS}	SDA, SCL Logic Input Threshold Voltage Hysteresis	(Note 3)		50			mV
C_{IN}	Digital Input Capacitance SDAIN, SDAOUT, SCLIN, SCLOUT	(Note 3)			10		pF
I_{LEAK}	Input Leakage Current	SDA, SCL, Pins	●		±5		μA
V_{OL}	Output Low Voltage	SDA, SCL Pins, $I_{SINK} = 4\text{mA}$, SDAIN/SCLIN = 0.2V, $V_{CC} = 2.7\text{V}$	●	0	0.4		V
		2.7k to V_{CC} on SDA, SCL, $V_{CC} = 3.3\text{V}$, Driven SDA, SCL = 0.1V	●	120	160	205	mV
V_{ILMAX}	Buffer Input Logic Low Voltage	$V_{CC} = 3.3\text{V}$	●		1.2		V
Timing Characteristics							
f_{I2C_MAX}	I ² C Maximum Operating Frequency	(Note 3)		400	600		kHz
t_{BUF}	Bus Free Time Between Stop and Start Condition	(Note 3)			1.3		μs
t_{HD_STA}	Hold Time After (Repeated) Start Condition	(Note 3)			100		ns
t_{SU_STA}	Repeated Start Condition Set-Up Time	(Note 3)			0		ns
t_{SU_STO}	Stop Condition Set-Up Time	(Note 3)			0		ns
t_{HD_DAT}	Data Hold Time Input	(Note 3)			0		ns
t_{SU_DAT}	Data Set-Up Time	(Note 3)			100		ns

Note 1: Stresses beyond those listed under Absolute Maximum Ratings may cause permanent damage to the device. Exposure to any Absolute Maximum Rating condition for extended periods may affect device reliability and lifetime.

Note 2: See “Propagation Delays” in the Operations section for a discussion of t_{PHL} and t_{PLH} as a function of pull-up resistance and bus capacitance.

Note 3: Determined by design, not tested in production.

Note 4: Measure points are $0.3 \cdot V_{CC}$ and $0.7 \cdot V_{CC}$.

Note 5: I_{CC} test performed with connection circuitry active.

Note 6: All currents into pins are positive; all voltages are referenced to GND unless otherwise specified.

TIMING DIAGRAMS

ENABLE, CONNECT, READY Timing

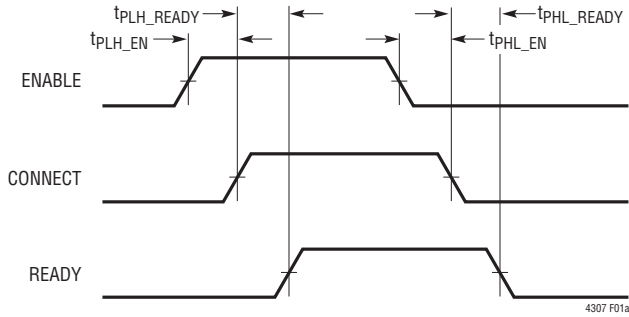

Rising and Falling Propagation Delay and Rise and Fall Times for SDAIN, SDAOUT and SCLIN, SCLOUT

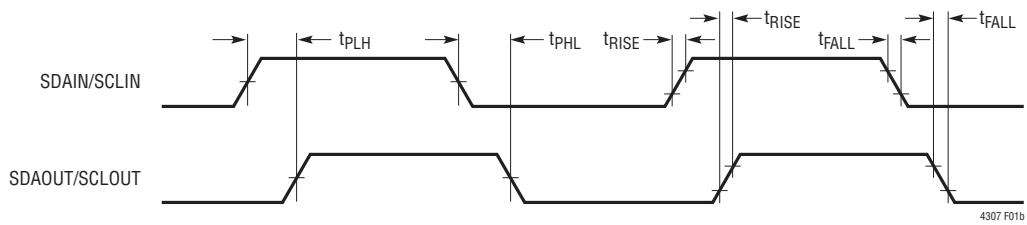
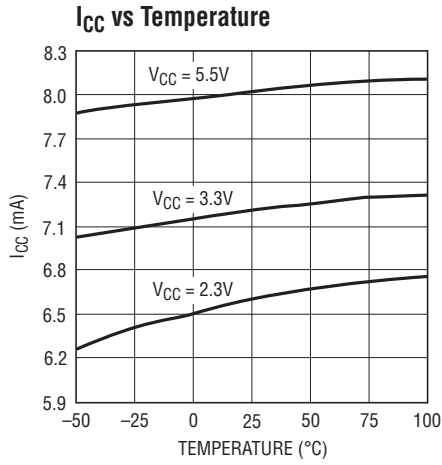
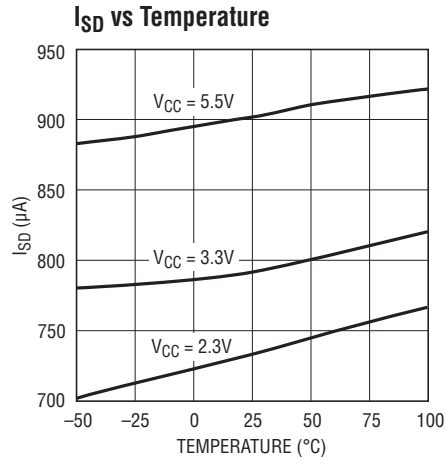

Figure 1. Timing Diagrams

TYPICAL PERFORMANCE CHARACTERISTICS $T_A = 25^\circ\text{C}$, $V_{CC} = 3.3\text{V}$, unless otherwise indicated.



4307 G01



4307 G02

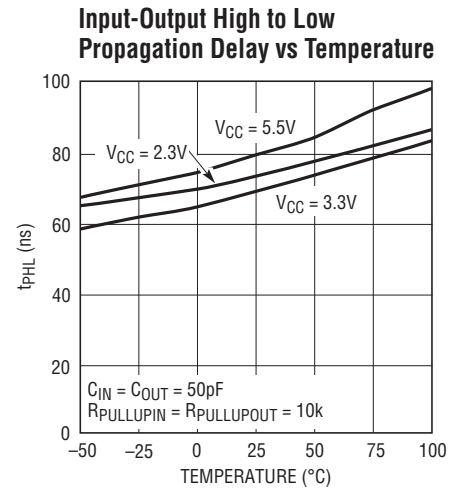

4307 G03

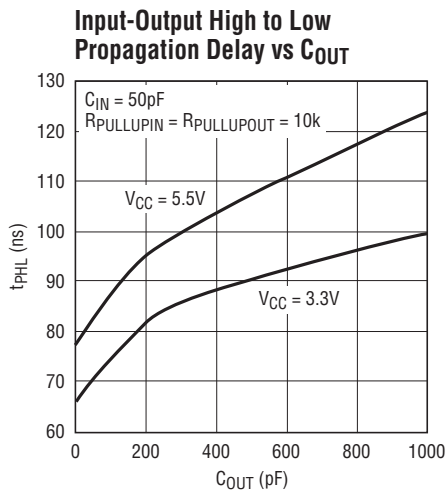

4307 G04

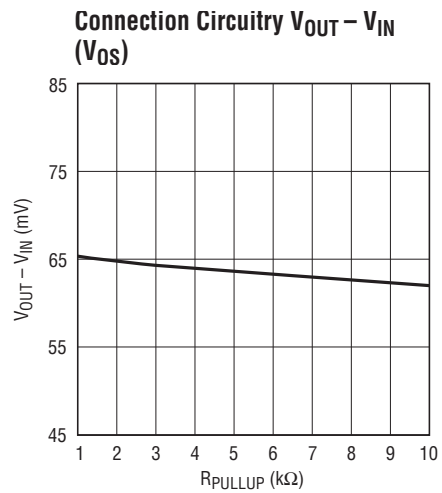

4307 G05

PIN FUNCTIONS

ENABLE (Pin 1): Connection Enable Input. This is a 1.4V digital threshold input pin. For normal operation pull or tie ENABLE high. Driving ENABLE below 0.8V isolates SDAIN from SDAOUT, SCLIN from SCLOUT and asserts READY low. A rising edge on ENABLE after a fault has occurred forces a connection between SDAIN, SDAOUT and SCLIN, SCLOUT. Connect to V_{CC} if unused.

SCLOUT (Pin 2): Serial Clock Output. Connect this pin to the clock line of a DDC bus. A pull-up resistor should be connected between this pin and a supply voltage greater than or equal to the V_{CC} voltage.

SCLIN (Pin 3): Serial Clock Input. Connect this pin to the clock line of a DDC bus. A pull-up resistor should be connected between this pin and a supply voltage greater than or equal to the V_{CC} voltage.

GND (Pin 4): Device Ground. Connect this pin to a ground plane for best results.

READY (Pin 5): Connection READY Status Output. The READY pin is an open-drain N-channel MOSFET output that

pulls low when ENABLE is low, or when the start-up and connection sequence described in the Operation section has not been completed. READY goes high when ENABLE is high and a connection is made. READY can be used to control the HDMI HPD signal. Connect a pull-up resistor, typically 10k, from this pin to V_{CC} to provide the pull-up. This pin can be floated if unused.

SDAIN (Pin 6): Serial Data Input. Connect this pin to the data line of a DDC bus. A pull-up resistor should be connected between this pin and a supply voltage greater than or equal to the V_{CC} voltage.

SDAOUT (Pin 7): Serial Data Output. Connect this pin to the data line of a DDC bus. A pull-up resistor should be connected between this pin and a supply voltage greater than or equal to the V_{CC} voltage.

V_{CC} (Pin 8): Supply Voltage Input. Place a bypass capacitor of at least 0.01 μ F close to V_{CC} for best results.

Exposed Pad (Pin 9, DFN Package Only): Exposed Pad may be left open or connected to device ground.

BLOCK DIAGRAM

Low Offset Level-Shifting 2-Wire Bus Buffer

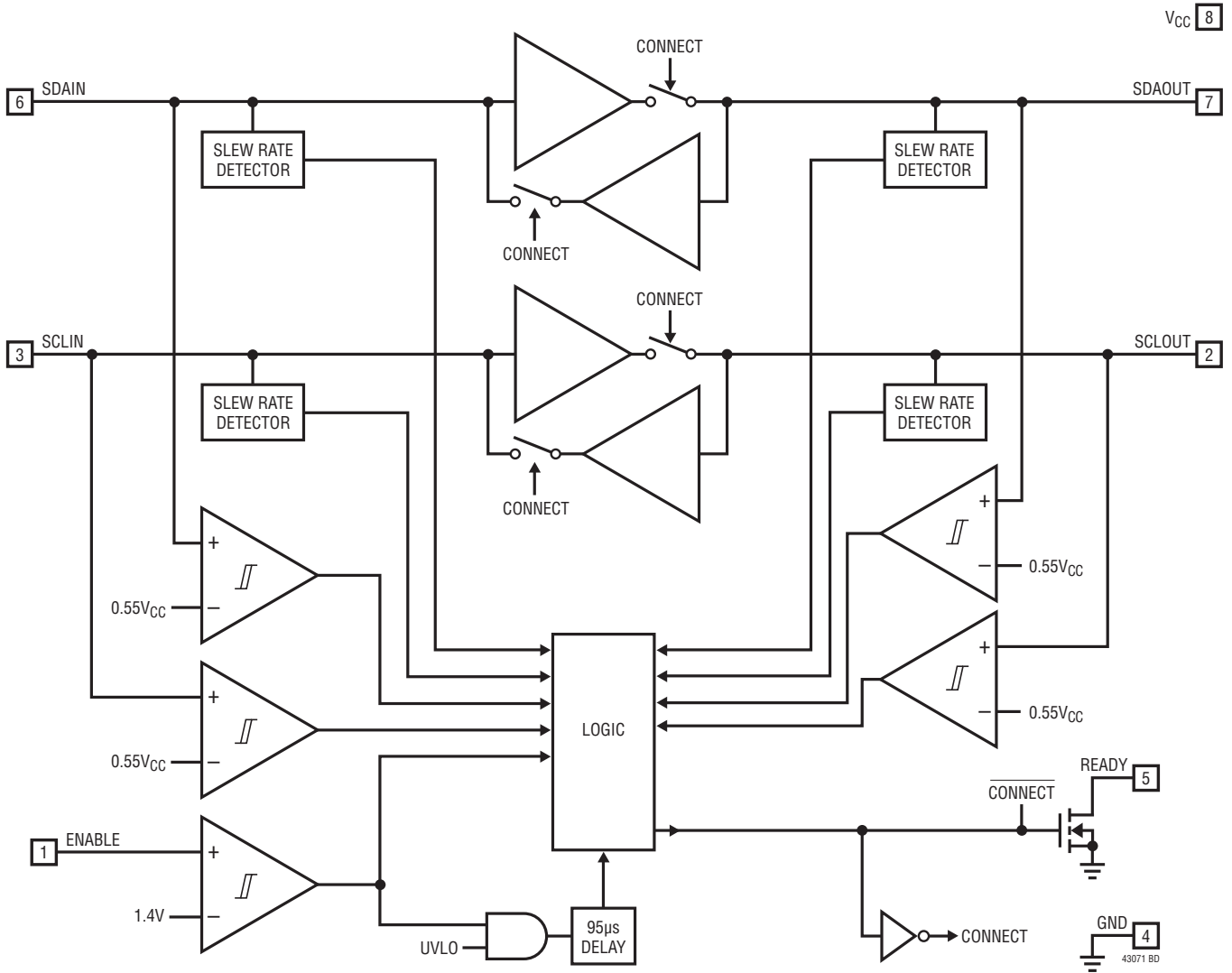

OPERATION

Start-Up

When the LTC4307-1 first receives power on its V_{CC} pin during power-up, it starts in an undervoltage lockout (UVLO) state, ignoring any activity on the SDA or SCL pins until V_{CC} rises above 2V (typ). This is to ensure that the LTC4307-1 does not try to function until it has enough voltage to do so.

Once the LTC4307-1 comes out of UVLO, it monitors both 2-wire busses for either a stop bit or bus idle condition to indicate the completion of data transactions. When both sides are idle or one side has a stop bit condition while the other is idle, the input-to-output connection circuitry is activated, joining SDAIN to SDAOUT and SCLIN to SCLOUT.

Connection Circuitry

Once the connection circuitry is activated, the functionality of the SDAIN and SDAOUT pins is identical. A low forced on either pin at any time results in both pin voltages being low. The LTC4307-1 is tolerant of I²C bus DC logic low voltages up to the $0.3V_{CC} V_{IL}$ I²C specification.

When the LTC4307-1 senses a rising edge on the bus, it deactivates its pull-down devices for bus voltages as low as 0.48V. Care must be taken to ensure that devices participating in clock stretching or arbitration force logic low voltages below 0.48V at the LTC4307-1 inputs.

SDAIN and SDAOUT enter a logic high state only when all devices on both SDAIN and SDAOUT release high. The same is true for SCLIN and SCLOUT. This important feature ensures that clock stretching, clock synchronization, arbitration and the acknowledge protocol always work, regardless of how the devices in the system are tied to the LTC4307-1.

Another key feature of the connection circuitry is that it provides bidirectional buffering, keeping the capacitances of the two 2-wire busses isolated from each other. Placing an LTC4307-1 close to an HDMI port inside an HDMI transmitter or receiver allows the HDMI device to pass the capacitance compliance specification. Because of this isolation, the waveforms on SDAIN and SCLIN look slightly different than the corresponding waveforms on SDAOUT and SCLOUT as described here.

Input to Output Offset Voltage

When a logic low voltage, V_{LOW1} , is driven on any of the LTC4307-1's data or clock pins, the LTC4307-1 regulates the voltage on the opposite data or clock pins to a slightly higher voltage, typically 60mV above V_{LOW1} . This offset is practically independent of pull-up current (see the Typical Performance curves).

Propagation Delays

During a rising edge, the rise time on each side is determined by the bus pull-up resistor and the equivalent capacitance on the line. If the pull-up resistors are the same, a difference in rise time occurs which is directly proportional to the difference in capacitance between the two sides. Users must account for differences in the RC time constants between the two 2-wire busses and ensure that all system timing specifications are met on both busses.

There is a finite propagation delay through the connection circuitry for falling waveforms. Figure 2 shows the falling edge waveforms for $V_{CC} = 5.5V$, a 10k pull-up resistor on each side, 150pF parasitic capacitance on the input bus and 50pF on the output pins. An external N-channel MOSFET device pulls down the voltage on the side with 150pF capacitance; the LTC4307-1 pulls down the voltage on the opposite side with a delay of 80ns. This delay is always positive and is a function of supply voltage, temperature and the pull-up resistors and equivalent bus capacitances on both sides of the bus. The Typical Performance Characteristics section shows propagation delay as a function of temperature and voltage for 10k pull-up resistors and 50pF equivalent capacitance on both sides of the part. Also, the t_{PHL} vs C_{OUT} curve for $V_{CC} = 5.5V$ shows that increasing the

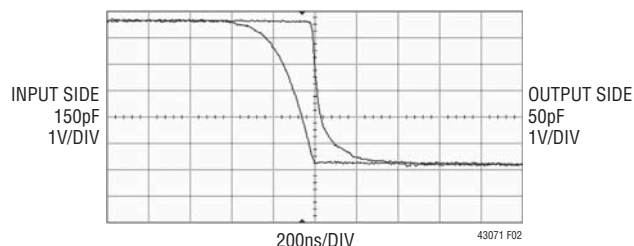

Figure 2. Input-Output Falling Edge Waveforms

OPERATION

capacitance from 50pF to 150pF results in a t_{pHL} increase from 81ns to 91ns. Larger output capacitances translate to longer delays (up to 125ns). Users must quantify the difference in propagation times for a rising edge versus a falling edge in their systems and adjust setup and hold times accordingly.

READY Digital Output

This pin provides a digital flag which is low when either ENABLE is low or the start-up sequence described earlier in this section has not been completed. READY goes high when ENABLE is high and the input and output 2-wire busses are connected. The pin is driven by an open-drain pull-down capable of sinking 3mA while holding 0.4V on the pin. Connect a resistor to V_{CC} to provide the pull-up.

READY can be used to control the HDMI hot plug detect (HPD) signal to prevent the possibility of erroneous attempts by the source to contact the sink before the sink is ready to communicate.

ENABLE

When the ENABLE pin is driven below 0.8V with respect to the LTC4307-1's ground, the input 2-wire bus is disconnected from the output 2-wire bus and the READY pin is internally pulled low. When the pin is driven above 2V, the part waits for data transactions on both 2-wire busses to be complete (as described in the Start-Up section) before connecting the two sides. At this time the internal pull-down on READY releases.

LTC4307 and LTC4307-1 Feature Differences

The LTC4307-1 HDMI level-shifting 2-wire bus buffer is specifically intended for HDMI applications. Features in the general purpose LTC4307 device that are not required in HDMI systems have been removed. In addition, level-shifting functionality has been added to the LTC4307-1 to allow 3.3V HDMI devices to interface safely to the 5V HDMI DDC bus. See Table 1 for a list of the differences between the LTC4307 and LTC4307 -1.

Table 1. Differences Between the LTC4307 and the LTC4307-1

SPECIFICATION	LTC4307	LTC4307-1	COMMENTS ON LTC4307-1
Pre-charge	Yes	No	HDMI DDC Lines are Not Hot Swapped
Level Shifting	No	Yes, 2.2V to 5.5V	Provides Communication Between 3.3V and 5V DDC Busses, Protects 3.3V Devices from 5V Supply
Stuck Bus Disconnect and Recovery	Yes	No	Stuck Busses, Not an Issue in HDMI Systems
Rise Time Accelerators	Yes	No	Complies with HDMI Specification Version 1.3 DDC Capacitance Requirement

APPLICATIONS INFORMATION

Figure 3 shows the LTC4307-1 in a capacitance buffering application. Due to the LTC4307-1's capacitance buffering feature and sub-10pF input capacitance, this application circuit passes the HDMI 50pF maximum DDC capacitance specification easily when the LTC4307-1 is located right at the HDMI connector interface as shown. The capacitance of the internal bus connected to the SDAIN and SCLIN pins may be much larger than 50pF, but because of the LTC4307-1's capacitance buffering, the internal bus capacitance is isolated from the HDMI connector.

In HDMI, the sink device pulls the hot plug detect HPD signal high to tell the source that it is ready to accept commands through the DDC. This signal can be controlled through the READY pin of the LTC4307-1 to prevent the possibility of erroneous attempts by the source to contact the sink before the sink is ready to return its extended display identification data (EDID). The READY pin only goes high after 5V is applied and the LTC4307-1 ENABLE pin is pulled high by the HDMI receiver IC, a controller in the sink, or the 5V line itself.

APPLICATIONS INFORMATION

Figure 4 shows the LTC4307-1 being used for capacitance buffering and 5V to 3.3V level shifting. In this application, the EEPROM is powered by a backup 3.3V supply that is available when the component is turned off. The EDID in the EEPROM should be available for reading even when a component's power is off.

Although the applications shown in this section are for HDMI receive channels, the LTC4307-1 can also be used in HDMI transmit channels with equal success as shown in the Typical Application on the last page of this data sheet.

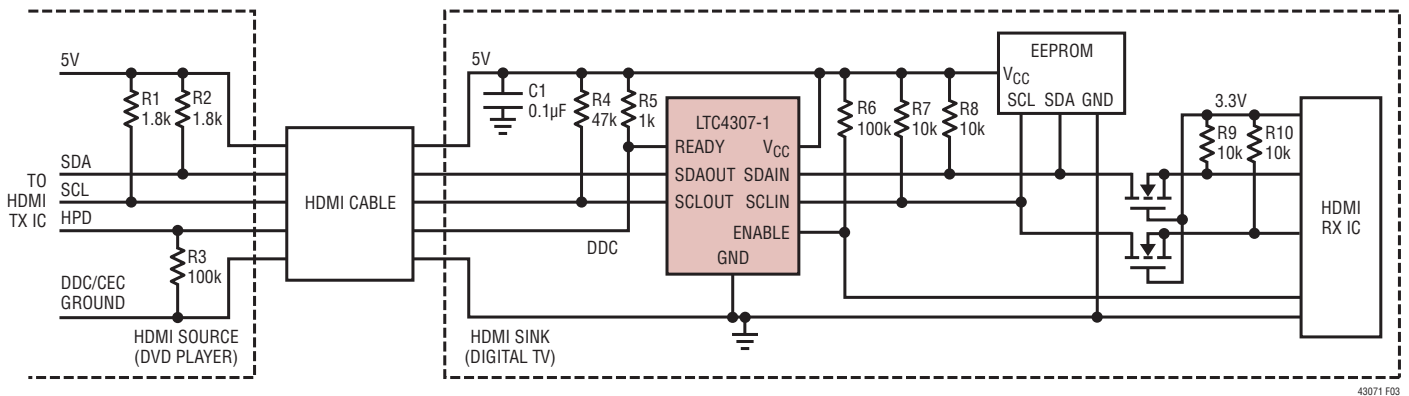

Figure 3. The LTC4307-1 in HDMI Capacitance Buffering Application

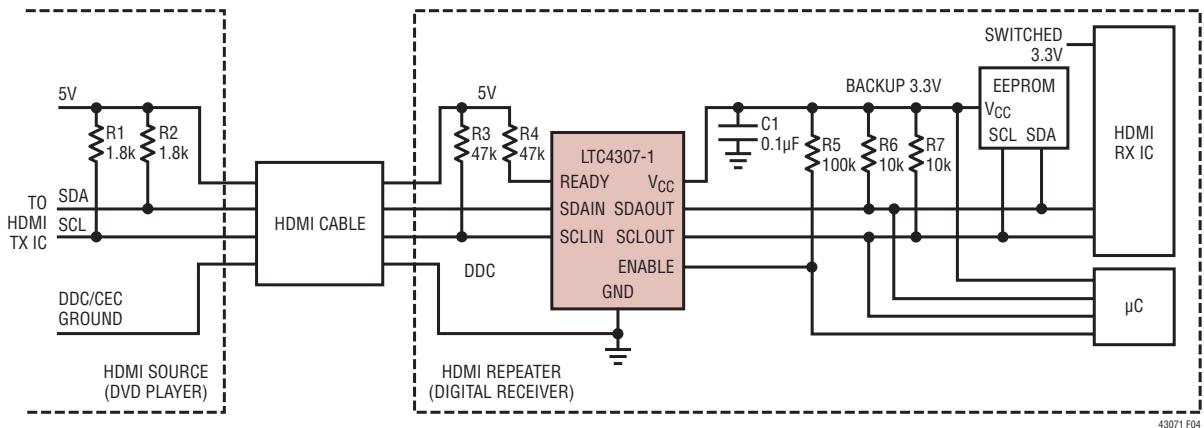
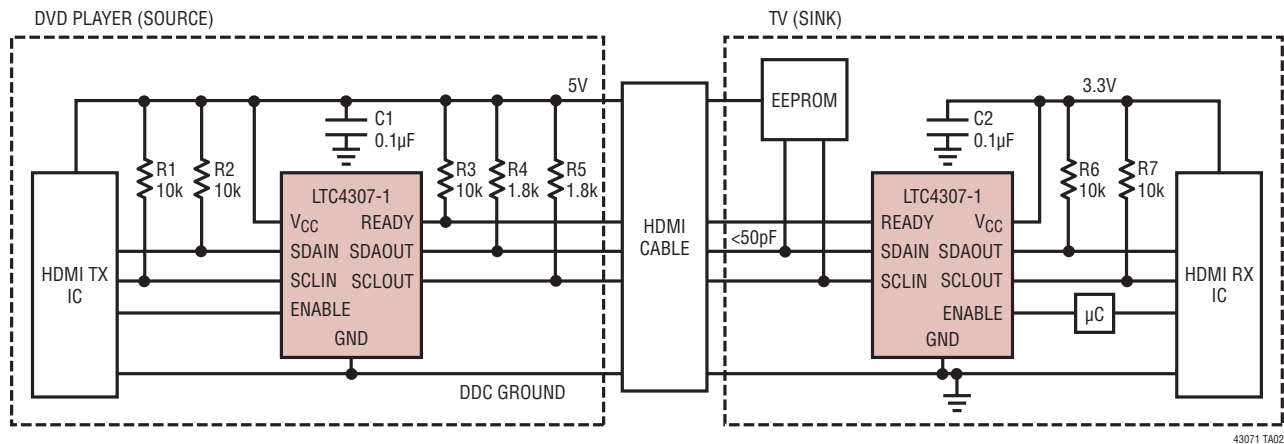

Figure 4. The LTC4307-1 in a Level Shifting and Capacitance Buffering HDMI Application with Backup 3.3V

LTC4307-1

TYPICAL APPLICATION

HDMI Application with LTC4307-1's Providing Capacitance Buffering On Both the Transmit and Receive Channels



RELATED PARTS

PART NUMBER	DESCRIPTION	COMMENTS
LTC1380/LTC1393	Single-Ended 8-Channel/Differential 4-Channel Analog MUX with SMBus Interface	Low R_{ON} : 35 Ω Single Ended/70 Ω Differential, Expandable to 32 Single or 16 Differential Channels
LTC1427-50	Micropower, 10-Bit Current Output DAC with SMBus Interface	Precision 50 μ A \pm 2.5% Tolerance Over Temperature, Four Selectable SMBus Addresses, DAC Powers Up at Zero or Midscale
LTC1623	Dual High Side Switch Controller with SMBus Interface	Eight Selectable Addresses/16-Channel Capability
LTC1663	SMBus Interface 10-Bit Rail-to-Rail Micropower DAC	DNL < 0.75LSB Max, 5-Lead SOT-23 Package
LTC1694/LTC1694-1	SMBus Accelerator	Improved SMBus/ I^2 C Rise Time, Ensures Data Integrity with Multiple SMBus/ I^2 C Devices
LTC1695	SMBus/ I^2 C Fan Speed Controller in ThinSOT™ Package	0.75 Ω PMOS 180mA Regulator, 6-Bit DAC
LT1786F	SMBus Controlled CCFL Switching Regulator	1.25A, 200kHz Floating or Grounded Lamp Configurations
LTC1840	Dual I^2 C Fan Speed Controller	Two 100 μ A 8-Bit DACs, Two Tach Inputs, Four GPIO
LTC4300A-1/ LTC4300A-2/ LTC4300A-3	Hot Swappable 2-Wire Bus Buffers	LTC4300A-1: Bus Buffer with READY, ACC and ENABLE LTC4300A-2: Dual Supply Bus Buffer with READY and ACC LTC4300A-3: Dual Supply Bus Buffer with READY and ENABLE
LTC4301	Supply Independent Hot Swappable 2-Wire Bus Buffer	Supply Independent
LTC4301L	Hot Swappable 2-Wire Bus Buffer with Low Voltage Level Translation	Allows Bus Pull-Up Voltages as Low as 1V on SDAIN and SCLIN
LTC4302-1/LTC4302-2	Addressable 2-Wire Bus Buffer	Address Expansion, GPIO, Software Controlled
LTC4303/LTC4304	Hot Swappable 2-Wire Bus Buffers with Stuck Bus Recovery	Provides Automatic Clacking to Free Stuck I^2 C Busses
LTC4305/LTC4306	2-/4-Channel, 2-Wire Bus Multiplexers with Capacitance Buffering	2/4 Selectable Downstream Busses, Stuck Bus Disconnect, Rise Time Accelerators, Fault Reporting, \pm 10kV HBM ESD Tolerance
LTC4307	Low Offset Hot-Swappable 2-Wire Bus Buffer with Stuck Bus Recovery	60mV Buffer Offset, 30ms Stuck Bus Disconnect and Recovery

ThinSOT is a trademark of Linear Technology Corporation

Looking for pricing, stock, or lifecycle information?

Click below to explore more details on WIN SOURCE:

- ⊖ [View LTC4307CMS8-1#TRPBF](#) on WIN SOURCE
- ⊖ [Linear Technology](#) Information

Optimize Your Supply Chain with WIN SOURCE Solutions

- ✓ Global Sourcing Solution
- ✓ Obsolete Management
- ✓ Cost Control Management
- ✓ Shortage Management
- ✓ Alternative Solution
- ✓ Excess Inventory Management