



**THE DATASHEET OF
LTC4263CS#PBF**



Single IEEE 802.3af Compliant PSE Controller with Internal Switch

FEATURES

- IEEE 802[®].3af Compliant
- Operation from a Single 48V Supply
- Fully Autonomous Operation without Microcontroller
- Internal MOSFET with Thermal Protection
- Power Management Works Across Multiple Ports with Simple RC Network
- Precision Inrush Control with Internal Sense Resistor
- Powered Device (PD) Detection and Classification
- AC and DC Disconnect Sensing
- Robust Short-Circuit Protection
- Pin-Selectable Detection Backoff for Midspan PSEs
- Classification Dependent I_{CUT} Current Threshold
- LED Driver Indicates Port On and Blinks Status Codes
- Available in 14-Pin SO and 4mm × 3mm DFN Packages

APPLICATIONS

- IEEE 802.3af Compliant Endpoint/Midspan PSEs
- Single-Port or Multi-Port Power Injectors
- Power Forwarders
- Low-Port Count PSEs
- Environment B PSEs
- Standalone PSEs

LT, LT, LTC, LTM, Linear Technology and the Linear logo are registered trademarks of Linear Technology Corporation. Hot Swap and ThinSOT are trademarks of Linear Technology Corporation. All other trademarks are the property of their respective owners.

DESCRIPTION

The LTC[®]4263 is an autonomous single-channel PSE controller for use in IEEE 802.3af compliant Power over Ethernet systems. It includes an onboard power MOSFET, internal inrush, current limit, and short-circuit control, IEEE 802.3af compliant PD detection and classification circuitry, and selectable AC or DC disconnect sensing. Onboard control algorithms provide complete IEEE 802.3af compliant operation without the need of a microcontroller. The LTC4263 simplifies PSE implementation, needing only a single 48V supply and a small number of passive support components.

Programmable onboard power management circuitry permits multiple LTC4263s to allocate and share power in multi-port systems, allowing maximum utilization of the 48V power supply—all without the intervention of a host processor. The port current limit can be configured to automatically adjust to the detected PD class. Detection backoff timing is configurable for either Endpoint or Midspan operation. Built-in foldback and thermal protection provide comprehensive fault protection.

An LED pin indicates the state of the port controlled by the LTC4263. When run from a single 48V supply, the LED pin can operate as a simple switching current source to reduce power dissipation in the LED drive circuitry.

The LTC4263 is available in 14-pin 4mm × 3mm DFN and 14-pin SO packages.

TYPICAL APPLICATION

Single-Port Fully Autonomous PSE

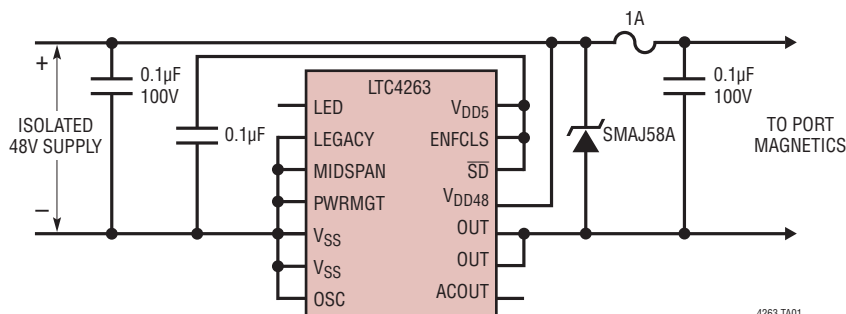

4263 TA01

4263fe

LTC4263

ABSOLUTE MAXIMUM RATINGS (Notes 1, 2)

Supply Voltages

$V_{SS} - V_{DD48}$ 0.3V to -80V

V_{DD5} $V_{SS} - 0.3V$ to $V_{SS} + 6V$

Pin Voltages and Currents

LEGACY, MIDSPAN, ENFCLS, PWRMGT

\overline{SD} , OSC $V_{SS} - 0.3V$ to $V_{SS} + 6V$

LED $V_{SS} - 0.3V$ to $V_{SS} + 80V$

OUT, ACOUT (See Note 3)

Operating Ambient Temperature Range

LTC4263C 0°C to 70°C

LTC4263I -40°C to 85°C

Junction Temperature (Note 4) 125°C

Storage Temperature Range -65°C to 150°C

Lead Temperature (Soldering, 10 sec)

SO 300°C

PIN CONFIGURATION

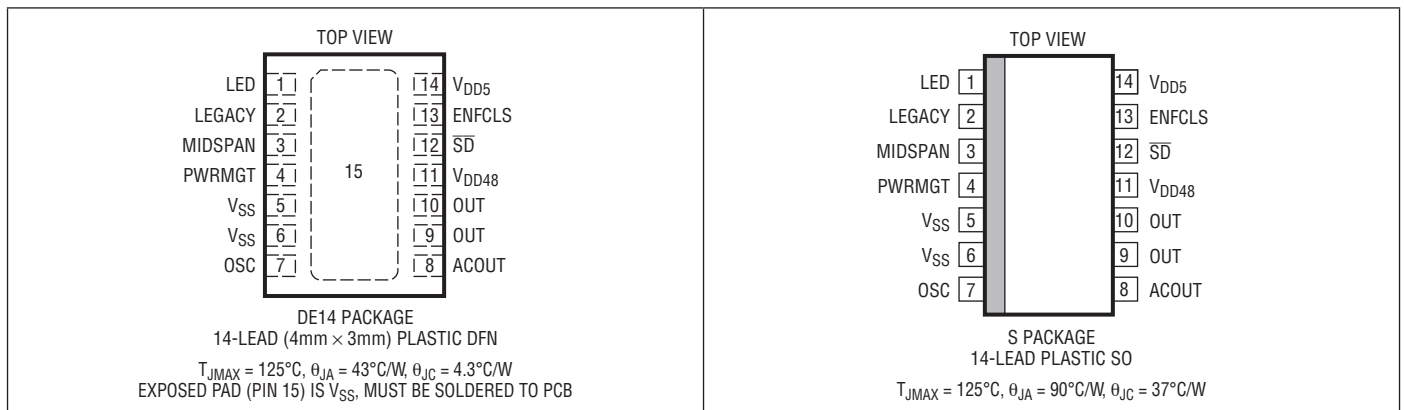

ORDER INFORMATION

LEAD FREE FINISH	TAPE AND REEL	PART MARKING*	PACKAGE DESCRIPTION	TEMPERATURE RANGE
LTC4263CDE#PBF	LTC4263CDE#TRPBF	4263	14-Lead (4mm x 3mm) Plastic DFN	0°C to 70°C
LTC4263IDE#PBF	LTC4263IDE#TRPBF	4263	14-Lead (4mm x 3mm) Plastic DFN	-40°C to 85°C
LTC4263CS#PBF	LTC4263CS#TRPBF	4263CS	14-Lead Plastic SO	0°C to 70°C
LTC4263IS#PBF	LTC4263IS#TRPBF	4263IS	14-Lead Plastic SO	-40°C to 85°C

Consult LTC Marketing for parts specified with wider operating temperature ranges. *The temperature grade is identified by a label on the shipping container.

For more information on lead free part marking, go to: <http://www.linear.com/leadfree/>

For more information on tape and reel specifications, go to: <http://www.linear.com/tapeandreel/>

ELECTRICAL CHARACTERISTICS

The ● denotes the specifications which apply over the full operating temperature range, otherwise specifications are at $T_A = 25^\circ\text{C}$. $V_{DD48} - V_{SS} = 48V$ and V_{DD5} not driven externally. All voltages are relative to V_{SS} unless otherwise noted. (Notes 2, 5)

SYMBOL	PARAMETER	CONDITIONS	MIN	TYP	MAX	UNITS	
Power Supplies							
V_{SUPPLY}	48V Supply Voltage	$V_{DD48} - V_{SS}$	●	33	48	66	V
		To Maintain IEEE Compliant Output	●	46		57	V
V_{UVLO_OFF}	UVLO Turn-Off Voltage	$V_{DD48} - V_{SS}$ Decreasing	●	29	31	33	V
V_{UVLO_HYS}	UVLO Hysteresis		●	0.1		1	V

4263fe

ELECTRICAL CHARACTERISTICS The ● denotes the specifications which apply over the full operating temperature range, otherwise specifications are at $T_A = 25^\circ\text{C}$. $V_{DD48} - V_{SS} = 48\text{V}$ and V_{DD5} not driven externally. All voltages are relative to V_{SS} unless otherwise noted. (Notes 2, 5)

SYMBOL	PARAMETER	CONDITIONS		MIN	TYP	MAX	UNITS
V_{OVLO_OFF}	OVLO Turn-Off Voltage	$V_{DD48} - V_{SS}$ Increasing	●	66	70	74	V
V_{OVLO_HYS}	OVLO Hysteresis		●	0.2		2	V
V_{DD5}	V_{DD5} Supply Voltage	Driven Externally	●	4.5	5	5.5	V
	V_{DD5} Internal Supply	Driven Internally	●	4.3	4.4	4.5	V
I_{DD48}	V_{DD48} Supply Current	$V_{DD5} - V_{SS} = 5\text{V}$	●		1	2	mA
		Internal V_{DD5}	●		2	4	mA
I_{DD5}	V_{DD5} Supply Current	$V_{DD5} - V_{SS} = 5\text{V}$	●		1	2	mA

Power MOSFET

R_{ON}	On-Resistance	$I = 350\text{mA}$, Measured From OUT to V_{SS}	●		1.5	2.4	Ω
						3.0	Ω
I_{OUT_LEAK}	OUT Pin Leakage	$V_{OUT} - V_{SS} = V_{DD48} - V_{SS} = 57\text{V}$	●		1	10	μA
R_{PU}	OUT Pin Pull-Up Resistance to V_{DD48}	$0\text{V} \leq (V_{DD48} - V_{OUT}) \leq 5\text{V}$	●	360	500	640	k Ω

Current Control

I_{CUT}	Overload Current Threshold	Class 0, Class 3, Class 4 (Note 6)	●	355	375	395	mA
		Class 2	●	165	175	185	mA
		Class 1	●	95	100	105	mA
I_{LIM}	Short-Circuit Current Limit	$V_{OUT} - V_{SS} = 5\text{V}$	●	405	425	445	mA
		$V_{DD48} - V_{OUT} = 30\text{V}$	●	405	425	445	mA
I_{FB}	Foldback Current Limit	$V_{DD48} - V_{OUT} = 0\text{V}$ (Note 7)	●	30	60	120	mA
		$V_{DD48} - V_{OUT} = 10\text{V}$	●	110	140	180	mA
I_{MIN}	DC Disconnect Current Threshold		●	5.2	7.5	9.8	mA
I_{FAULT}	High Speed Fault Current Limit	(Note 8)	●	500	650	800	mA

Detection

I_{DET}	Detection Current	First Point, $V_{DD48} - V_{OUT} = 10\text{V}$	●	235	255	275	μA
		Second Point, $V_{DD48} - V_{OUT} = 3.5\text{V}$	●	160	180	200	μA
V_{DET}	Detection Voltage Compliance	$V_{DD48} - V_{OUT}$, Open Port $V_{DD48} - V_{SS} = 57\text{V}$	●			21	V
R_{DETMIN}	Minimum Valid Signature Resistance		●	15.5	17	18.5	k Ω
R_{DETMAX}	Maximum Valid Signature Resistance		●	27.5	29.7	32	k Ω
R_{OPEN}	Open Circuit Threshold		●	500		2000	k Ω

Classification

V_{CLASS}	Classification Voltage	$V_{DD48} - V_{OUT}$, $0\text{mA} \leq I_{CLASS} \leq 50\text{mA}$	●	16.5		20.5	V
I_{CLASS}	Classification Current Compliance	$V_{OUT} = V_{DD48}$	●	55	60	75	mA
I_{TCLASS}	Classification Threshold Current	Class 0 – 1	●	5.5	6.5	7.5	mA
		Class 1 – 2	●	13.5	14.5	15.5	mA
		Class 2 – 3 (Note 9)	●	21.5	23	24.5	mA

Power Management

V_{PWRMGT}	Power Management Pin Threshold		●	0.98	1	1.02	V
I_{PWRMGT}	Power Management Pin Output Current	Class 0, Class 3, Class 4	●	-75.6	-72.3	-69	μA
		Class 1	●	-19.6	-18.8	-17.9	μA
		Class 2	●	-34.3	-32.8	-31.3	μA

AC Disconnect

R_{OSC}	OSC Pin Input Impedance	$2\text{V} \leq (V_{OSC} - V_{SS}) \leq 3\text{V}$	●	175	250	325	k Ω
I_{OSC}	OSC Pin Output Current	$V_{OSC} - V_{SS} = 2\text{V}$	●	-140		140	μA
f_{OSC}	OSC Pin Frequency	$V_{OSC} - V_{SS} = 2\text{V}$	●	103	110	115	Hz

ELECTRICAL CHARACTERISTICS

The ● denotes the specifications which apply over the full operating temperature range, otherwise specifications are at $T_A = 25^\circ\text{C}$. $V_{DD48} - V_{SS} = 48\text{V}$ and V_{DD5} not driven externally. All voltages are relative to V_{SS} unless otherwise noted. (Notes 2, 5)

SYMBOL	PARAMETER	CONDITIONS		MIN	TYP	MAX	UNITS
A_{VACD}	Voltage Gain OSC to ACOUT	$2\text{V} \leq (V_{OSC} - V_{SS}) \leq 3\text{V}$	●	0.95	1.0	1.05	V/V
$I_{ACD\text{MAX}}$	AC Disconnect Output Current	$V_{OSC} - V_{SS} = 2\text{V}$, $0\text{V} \leq (V_{ACOUT} - V_{SS}) \leq 4\text{V}$	●	-1		1	mA
$I_{ACD\text{MIN}}$	Remain Connected AC Pin Current	$V_{OSC} - V_{SS} = 2\text{V}$	●	130	160	190	μA
V_{ACDEN}	AC Disconnect Enable Signal	$V_{OSC} - V_{SS}$, Port On	●	1.5			V

Digital Interface (Note 10)

V_{OLED}	LED Output Low Voltage	$I_{LED} = 10\text{mA}$	●		1.1	2.2	V
V_{ILD}	Digital Input Low Voltage	MIDSPAN, PWRMGT, ENFCLS, $\overline{\text{SD}}$ LEGACY	● ●			0.8 0.4	V V
V_{IHD}	Digital Input High Voltage	MIDSPAN, PWRMGT, ENFCLS, $\overline{\text{SD}}$ LEGACY	● ●	2.2 2.2			V
V_{OZ}	Voltage of Legacy Pin if Left Floating		●	1.1	1.25	1.4	V
I_{OLEG}	Current In/Out of Legacy Pin	$0\text{V} \leq (V_{LEGACY} - V_{SS}) \leq 5\text{V}$	●	-60		60	μA
I_{FLT}	Maximum Allowed Leakage of External Components at Legacy Pin in Force Power-On Mode		●	-10		10	μA

Timing Characteristics

t_{DET}	Detection Time	Beginning to End of Detection	●	270	290	310	ms
t_{DETDLY}	Detection Delay	PD Insertion to Detection Complete	●	300		620	ms
t_{PDC}	Classification Duration		●	34	37	39	ms
t_{PON}	Power Turn-On Delay	End of Valid Detect to Application of Power	●	135	145	155	ms
t_{RISE}	Turn-On Rise Time	$V_{DD48} - V_{OUT}$: 10% to 90% $C_{PSE} = 0.1\mu\text{F}$	●	40	170		μs
$t_{OVL D}$	Overload/Short-Circuit Time Limit		●	52	62	72	ms
t_{ED}	Error Delay	I_{CUT} Fault to Next Detect	●	3.8	4.0	4.2	s
t_{MPDO}	Maintain Power Signature (MPS) Disconnect Delay	PD Removal to Power Removal	●	320	350	380	ms
t_{MPS}	MPS Minimum Pulse Width	PD Minimum Current Pulse Width Required to Stay Connected (Note 11)	●			20	ms
t_{DBO}	Midspan Mode Detection Backoff	$R_{PORT} = 15.5\text{k}\Omega$	●	3.0	3.2	3.4	s
t_{DISDLY}	Power Removal Detection Delay		●	0.8	0.95	1.1	s

Note 1: Stresses beyond those listed under Absolute Maximum Ratings may cause permanent damage to the device. Exposure to any Absolute Maximum Rating condition for extended periods may affect device reliability and lifetime.

Note 2: All currents into device pins are positive; all currents out of device pins are negative. All voltages are referenced to V_{SS} unless otherwise specified.

Note 3: 80mA of current may be pulled from the OUT or ACOUT pin without damage whether the LTC4263 is powered or not. These pins will also withstand a positive voltage of $V_{SS} + 80\text{V}$.

Note 4: This IC includes overtemperature protection that is intended to protect the device during momentary overload conditions. Junction temperature will exceed 125°C when overtemperature protection is active. Continuous operation above the specified maximum operating junction temperature may impair device reliability.

Note 5: The LTC4263 operates with a negative supply voltage. To avoid confusion, voltages in this data sheet are referred to in terms of absolute magnitude.

Note 6: If the ENFCLS pin is high, I_{CUT} depends on the result of classification. If ENFCLS pin is low, I_{CUT} reverts to its Class 0 specification.

Note 7: In order to reduce power dissipated in the switch while charging the PD, the LTC4263 reduces the current limit when $V_{OUT} - V_{SS}$ is large. Refer to the Typical Performance Characteristics for more information.

Note 8: The LTC4263 includes a high speed current limit circuit intended to protect against faults. The fault protection is activated for port current in excess of I_{FAULT} . After the high speed current limit activates, the short-circuit current limit (I_{LIM}) engages and restricts current to IEEE 802.3af levels.

Note 9: Class 4 or higher classification current is treated as Class 3.

Note 10: The LTC4263 digital interface operates with respect to V_{SS} . All logic levels are measured with respect to V_{SS} .

Note 11: The IEEE 802.3af specification allows a PD to present its Maintain Power Signature (MPS) on an intermittent basis without being disconnected. In order to stay powered, the PD must present the MPS for t_{MPS} within any t_{MPDO} time window.

TYPICAL PERFORMANCE CHARACTERISTICS

Powering an IEEE 802.3af PD

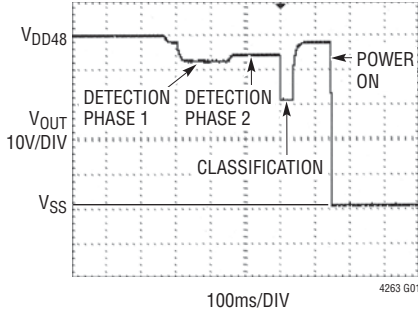

Powering a Legacy PD with 220µF Bypass Capacitor

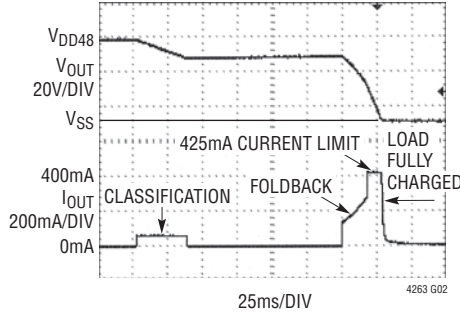

Classification Transient Response to 40mA Load Step

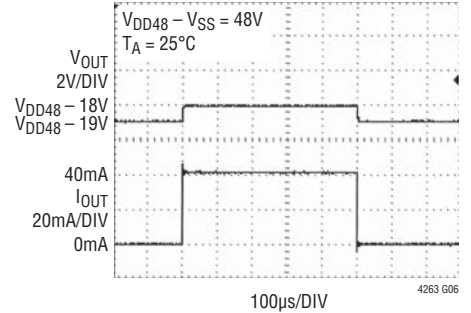

Overload Restart Delay

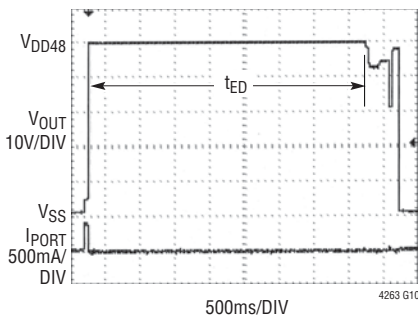

Midspan Backoff with Invalid PD

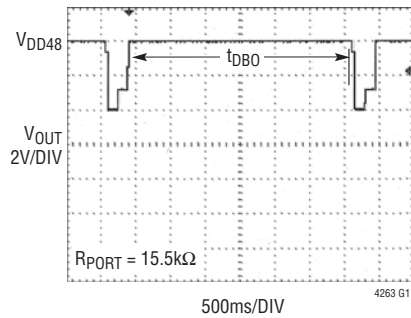

Overcurrent Response Time

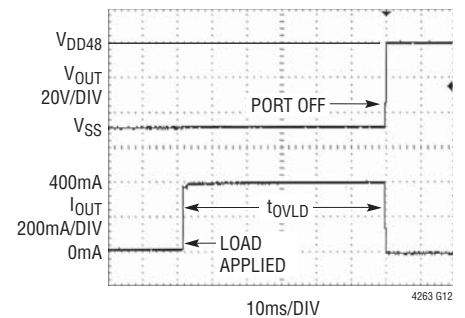

Response to PD Removal with AC Disconnect Enabled

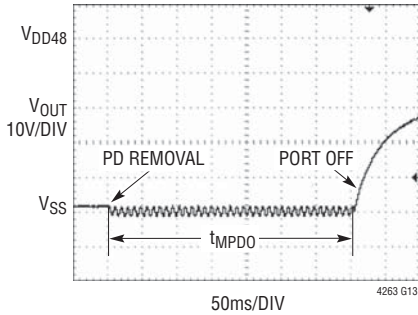

Rapid Response to 1Ω Short

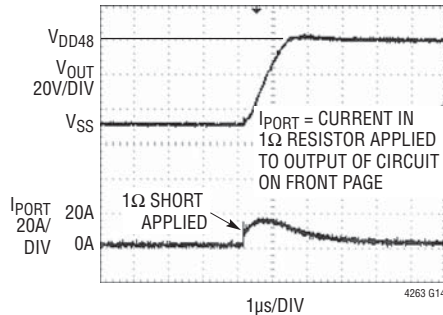

Rapid Response to Momentary 50Ω Short

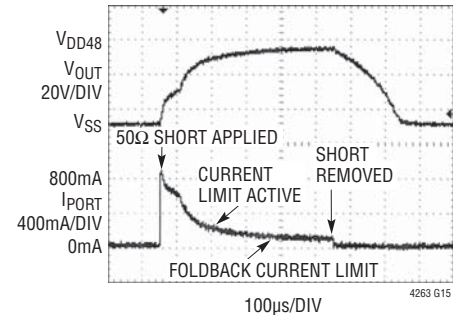

I_{PORT} = CURRENT IN 50Ω RESISTOR APPLIED TO OUTPUT OF CIRCUIT ON FRONT PAGE

TYPICAL PERFORMANCE CHARACTERISTICS

Current Limit and Foldback

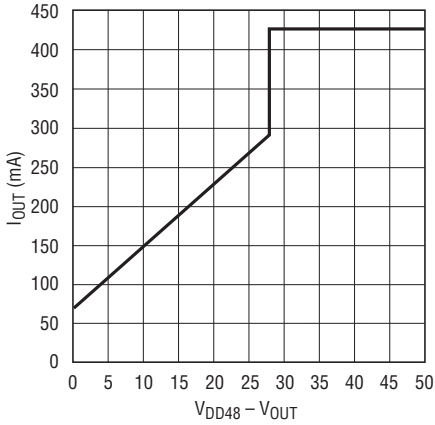

4263 G03

LED Pin Pulldown vs Load Current

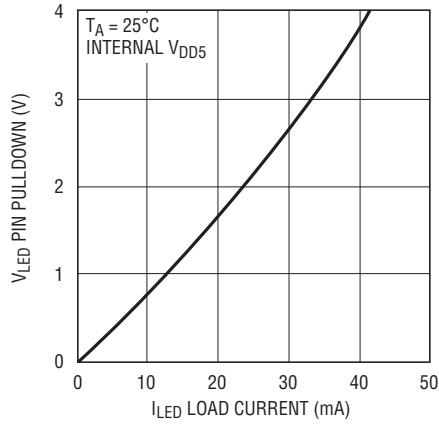

4263 G04

Classification Current Compliance

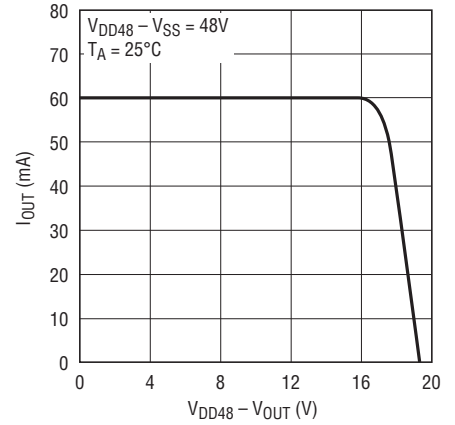

4263 G05

IDD48 DC Supply Current vs Supply Voltage with Internal VDD5

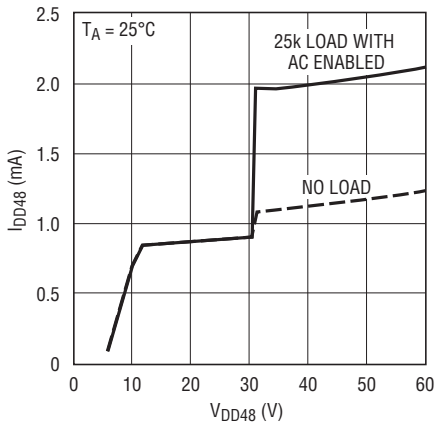

4263 G07

IDD48 DC Supply Current vs Supply Voltage with VDD5 = 5.0V

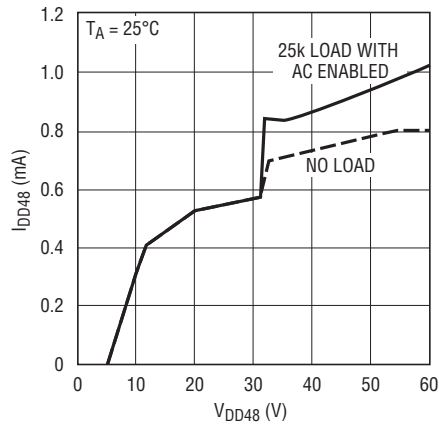

4263 G08

IDD5 DC Supply Current vs Supply Voltage

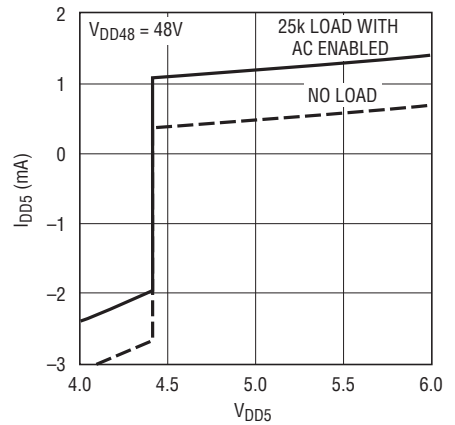

4263 G09

RON vs Temperature

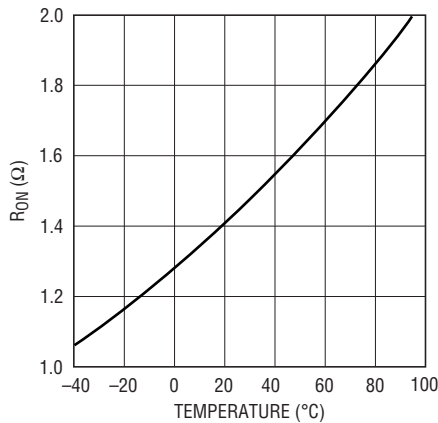

4263 G16

Legacy Pin Current vs Voltage

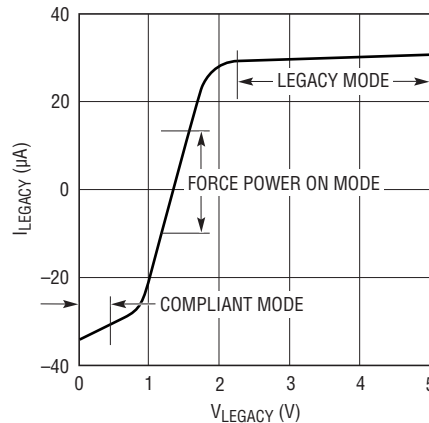

4263 G17

TEST TIMING

Detect, Class and Turn-On Timing

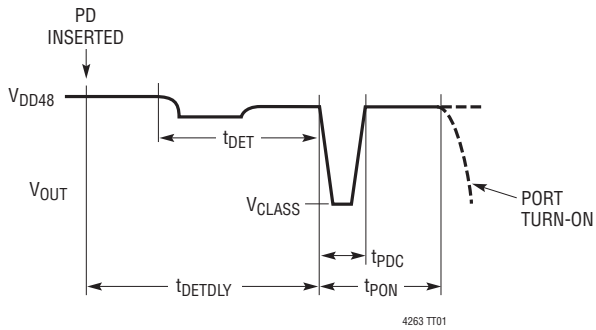

Current Limit Timing

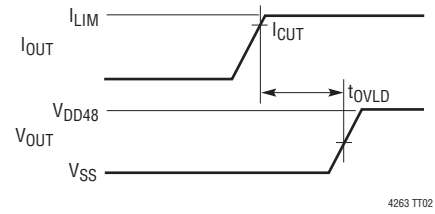

DC Disconnect Timing

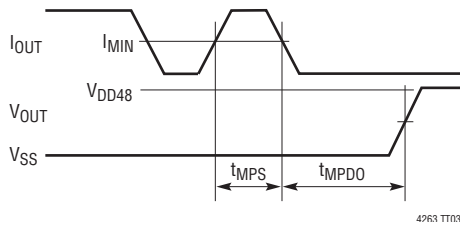

AC Disconnect Timing

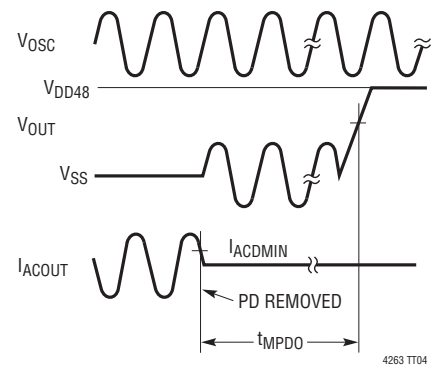

PIN FUNCTIONS (DFN/SO)

LED (Pin 1): Port State LED Drive. This pin is an open drain output that pulls down when the port is powered. Under port fault conditions, the LED will flash in patterns to indicate the nature of the port fault. See the Applications Information section for a description of these patterns. When the LTC4263 is operated from a single 48V supply, this pin is pulsed low with a 6% duty cycle during the periods when the LED should be on. This allows use of a simple inductor, diode, and resistor circuit to avoid excess heating due to the large voltage drop from V_{DD48} . See the Applications Information section for details on this circuit.

LEGACY (Pin 2): Legacy Detect. This pin controls whether legacy detect is enabled. If held at V_{DD5} , legacy detect is enabled and testing for a large capacitor is performed to detect the presence of a legacy PD on the port. See the Applications Information section for descriptions of legacy PDs that can be detected. If held at V_{SS} , only IEEE 802.3af compliant PDs are detected. If left floating, the LTC4263 enters force-power-on mode and any PD that generates between 1V and 10V when biased with 270 μ A of detection current will be powered as a legacy device. This mode is useful if the system uses a differential detection scheme to detect legacy devices. Warning: Legacy modes are not IEEE 802.3af compliant.

MIDSPAN (Pin 3): Midspan Enable. If this pin is connected to V_{DD5} , Midspan backoff is enabled and a 3.2 second delay occurs after every failed detect cycle unless the result is open circuit. If held at V_{SS} , no delay occurs after failed detect cycles.

PWRMGT (Pin 4): Power Management. The LTC4263 sources current at the PWRMGT pin proportional to the class of the PD that it is powering. The voltage of this pin is checked before powering the port. The port will not turn on if this pin is more than 1V above V_{SS} . Connect the PWRMGT pins of multiple LTC4263s together with a resistor and capacitor to V_{SS} to implement power management. If power management is not used, tie this pin to V_{SS} .

V_{SS} (Pins 5, 6): Negative 48V Supply. Pins 5 and 6 should be tied together on the PCB.

OSC (Pin 7) Oscillator for AC Disconnect. If AC disconnect is used, connect a 0.1 μ F X7R capacitor from OSC to V_{SS} . Tie OSC to V_{SS} to disable AC disconnect and enable DC disconnect.

ACOUT (Pin 8): AC Disconnect Sense. Senses the port to determine whether a PD is still connected when in AC disconnect mode. If port capacitance drops below about 0.15 μ F for longer than T_{MPDO} the port is turned off. If AC disconnect is used, connect this pin to the port with a series combination of a 1k resistor and a 0.47 μ F 100V X7R capacitor. See the Applications Information section for more information.

OUT (Pins 9, 10): Port Output. If DC disconnect is used, these pins are connected to the port. If AC disconnect is used, these pins are connected to the port through a parallel combination of a 1A diode and a 500k resistor. Pins 9 and 10 should be tied together on the PCB. See the Applications Information section for more information.

V_{DD48} (Pin 11): 48V Return. Must be bypassed with a 0.1 μ F capacitor to V_{SS} .

\overline{SD} (Pin 12): Shutdown. If held low, the LTC4263 is prevented from performing detection or powering the port. Pulling \overline{SD} low will turn off the port if it is powered. When released, a 4-second delay will occur before detection is attempted.

ENFCLS (Pin 13): Enforce Class Current Limits. If held at V_{DD5} , the LTC4263 will reduce the I_{CUT} threshold for class 1 or class 2 PDs. If ENFCLS is held at V_{SS} , I_{CUT} remains at 375mA (typ) for all classes.

V_{DD5} (Pin 14): Logic Power Supply. Apply 5V referenced to V_{SS} , if such a supply is available, or place a 0.1 μ F bypass capacitor to V_{SS} to enable the internal regulator. When the internal regulator is used, this pin should only be connected to the bypass capacitor and to any logic pins of the LTC4263 that are being held at V_{DD5} .

Exposed Pad (Pin 15, DE Package Only): V_{SS} . Must be connected to V_{SS} on the PCB. The Exposed Pad acts as a heatsink for the internal MOSFET.

BLOCK DIAGRAM

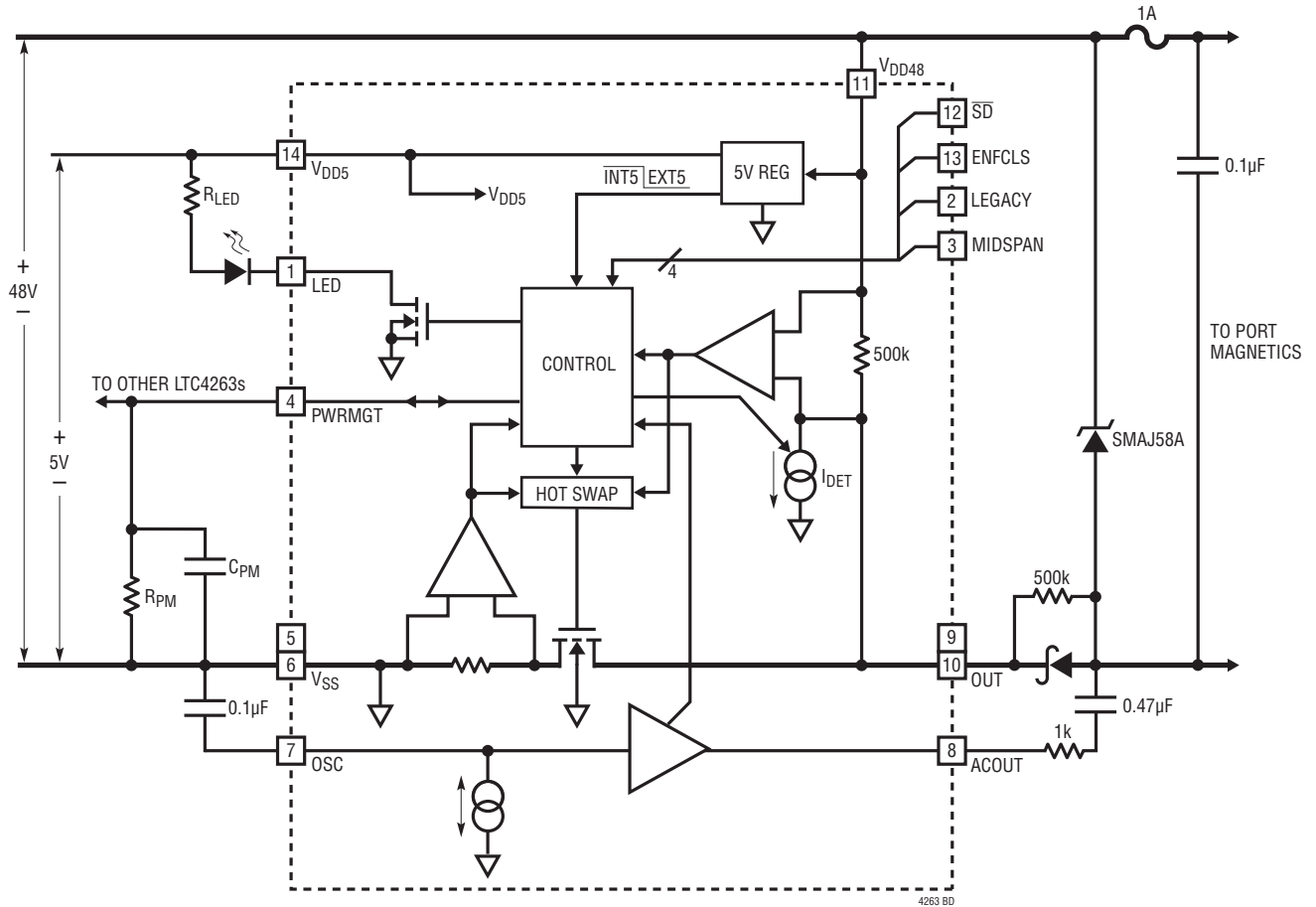

BOLD LINES INDICATE HIGH CURRENT

4263 BD

APPLICATIONS INFORMATION

POE OVERVIEW

Over the years, twisted-pair Ethernet has become the most commonly used method for local area networking. The IEEE 802.3 group, the originator of the Ethernet standard, has defined an extension to the standard, IEEE 802.3af, which allows DC power to be delivered simultaneously over the same cable used for data communication. This has enabled a whole new class of Ethernet devices, including IP telephones, wireless access points, and PDA charging stations which do not require additional AC wiring or external power transformers, a.k.a. “wall warts.” With about 13W of power available, small data devices can be powered by their Ethernet connections, free from AC wall outlets. Sophisticated detection and power monitoring techniques prevent damage to legacy data-only devices while still supplying power to newer, Ethernet-powered devices over the twisted-pair cable.

The device that supplies power is called the Power Sourcing Equipment (PSE). A device that draws power from the wire is called a Powered Device (PD). A PSE is typically an Ethernet switch, router, hub, or other network switching equipment that is commonly found in the wiring closets where cables converge. PDs can take many forms. Digital IP telephones, wireless network access points, PDA or notebook computer docking stations, cell phone chargers,

and HVAC thermostats are examples of devices that can draw power from the network.

A PSE is required to provide a nominal 48V DC between either the signal pairs or the spare pairs (but not both) as shown in Figure 1. The power is applied as a voltage between two of the pairs, typically by powering the center taps of the isolation transformers used to couple the differential data signals to the wire. Since Ethernet data is transformer coupled at both ends and is sent differentially, a voltage difference between the transmit pairs and the receive pairs does not affect the data. A 10Base-T/100Base-TX Ethernet connection only uses two of the four pairs in the cable. The unused or spare pairs can optionally be powered directly, as shown in Figure 1, without affecting the data. 1000Base-T uses all four pairs and power must be connected to the transformer center taps if compatibility with 1000Base-T is required.

The LTC4263 provides a complete PSE solution for detection and powering of PD devices in an IEEE 802.3af compliant system. The LTC4263 controls a single PSE port that will detect, classify, and provide isolated 48V power to a PD device connected to the port. The LTC4263 senses removal of a PD with IEEE 802.3af compliant AC or DC methods and turns off 48V power when the PD is disconnected. An internal control circuit takes care of system configuration and timing.

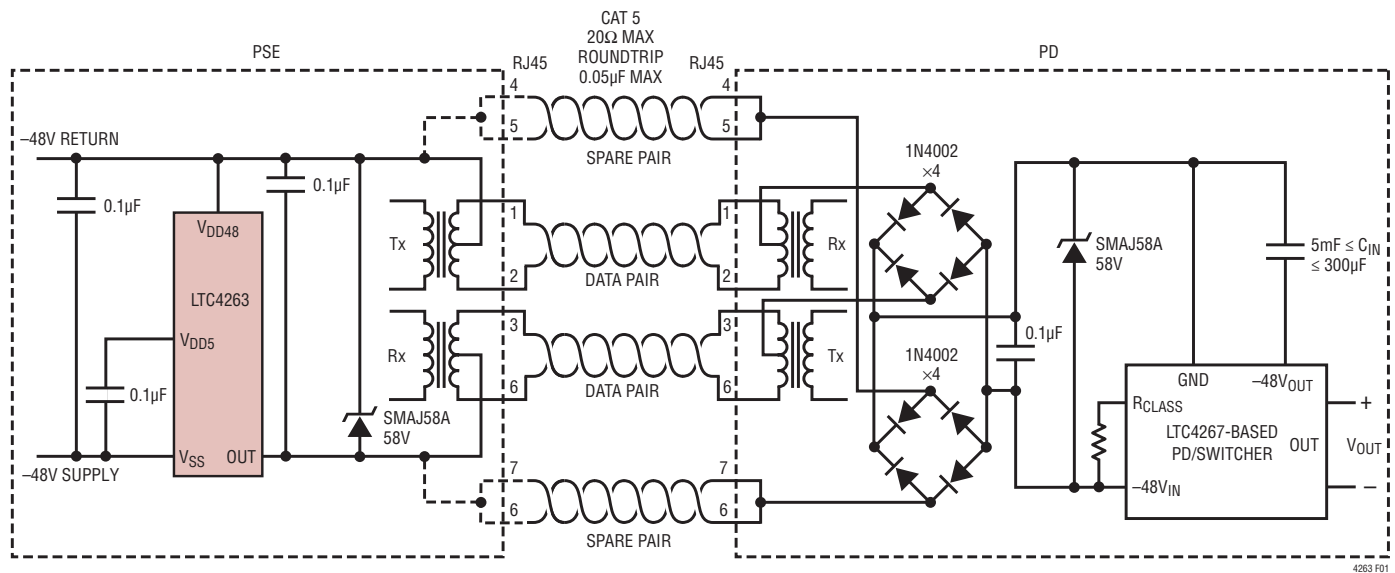

Figure 1. System Diagram

APPLICATIONS INFORMATION

LTC4263 OPERATION

Signature Detection

The IEEE 802.3af specification defines a specific pair-to-pair signature resistance used to identify a device that can accept power via its Ethernet connection. When the port voltage is below 10V, an IEEE 802.3af compliant PD will have an input resistance of approximately 25k Ω . Figure 2 illustrates the relationship between the PD signature resistance and the required resistance ranges the PSE must accept and reject. According to the IEEE 802.3af specification, the PSE must accept PDs with signatures between 19k Ω and 26.5k Ω and may or may not accept resistances in the two ranges of 15k Ω to 19k Ω and 26.5k Ω to 33k Ω . The black box in Figure 2 represents the typical 150 Ω pair-to-pair termination used in Ethernet devices like a computer's network interface card (NIC) that cannot accept power.

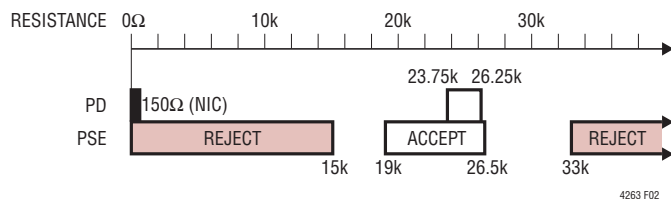

Figure 2. IEEE 802.3af Signature Resistance Ranges

The LTC4263 checks for the signature resistance by forcing two test currents on the port in sequence and measuring the resulting voltages. It then subtracts the two V-I points to determine the resistive slope while removing voltage offset caused by any series diodes or current offset caused by leakage at the port (see Figure 3). The LTC4263 will typically accept any PD resistance between 17k Ω and 29.7k Ω as a valid PD. Values outside this range (excluding open and short-circuits) are reported to the user by a code flashed via the LED pin.

The LTC4263 uses a force-current detection method in order to reduce noise sensitivity and provide a more robust detection algorithm. The first test point is taken by forcing a test current into the port, waiting a short time to allow

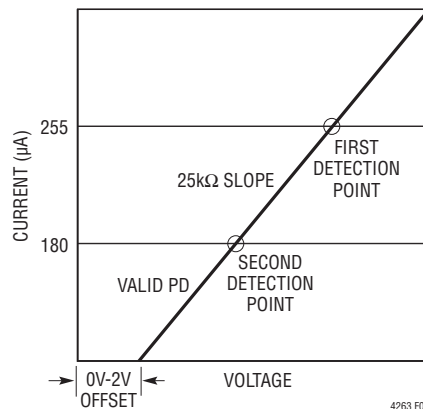

Figure 3. PD 2-Point Detection

the line to settle and measuring the resulting voltage. This result is stored and the second current is applied to the port, allowed to settle and the voltage measured.

The LTC4263 will not power the port if the PD has more than 5 μ F in parallel with its signature resistor unless legacy mode is enabled.

The LTC4263 autonomously tests for a valid PD connected to the port. It repeatedly queries the port every 580ms, or every 3.2s if midspan backoff mode is active (see below). If detection is successful, it performs classification and power management and then powers up the port.

Midspan Backoff

IEEE 802.3af requires the midspan PSE to wait two seconds after a failed detection before attempting to detect again unless the port resistance is greater than 500k Ω . This requirement is to prevent the condition of an endpoint PSE and a midspan PSE, connected to the same PD at the same time, from each corrupting the PD signature and preventing power-on. After the first corrupted detection cycle, the midspan PSE waits while the endpoint PSE completes detection and turns the port on. If the midspan mode of the LTC4263 is enabled by connecting the MIDSPAN pin to V_{DD5}, a 3.2 second delay occurs after every failed detect cycle unless the result is an open circuit.

APPLICATIONS INFORMATION

Classification

An IEEE 802.3af PD has the option of presenting a classification signature to the PSE to indicate how much power it will draw when operating. This signature consists of a specific constant-current draw when the PSE port voltage is between 15.5V and 20.5V, with the current level

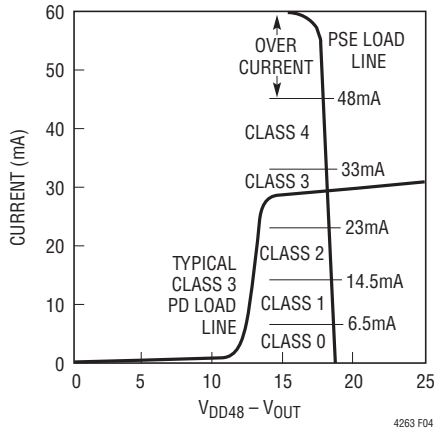

Figure 4. Classification Load Lines

indicating the power class to which the PD belongs. Per the IEEE 802.3af specification, there are five classes and three power levels for a PD as shown in Table 1. Note that class 4 is presently reserved by the IEEE for future use. Figure 4 shows an example PD load line, starting with the shallow slope of the 25k signature resistor below 10V, then drawing the classification current (in this case, class 3) between 15.5V and 20.5V. Also shown is the load line for the LTC4263. It maintains a low impedance until reaching current limit at 60mA (typ).

The LTC4263 will classify a port immediately after a successful detection. It measures the PD classification signature current by applying 18V (typ) to the port and measuring the resulting current. The LTC4263 identifies the three IEEE power levels and stores the detected class internally for use by the power management circuitry. In addition, the LTC4263 allows selectable enforcement of IEEE classification power levels. With the ENFCLS pin high, the LTC4263 reduces the I_{CUT} current threshold if it detects class 1 or class 2, thereby insuring that PDs which violate their advertised class are shut down.

Table 1. IEEE 802.3af Classification, PD Power Consumption, and LTC4263 Enforced Power Output

IEEE 802.3af CLASS	CLASSIFICATION CURRENT	MAXIMUM IEEE ALLOWABLE PD POWER	LTC4263 ENFORCED I_{CUT} THRESHOLD*	CLASS DESCRIPTION
0	0mA to 5mA	12.95W	375mA (typ)	PD Does Not Implement Classification, Unknown Power
1	8mA to 13mA	3.84W	100mA (typ)	Low Power PD
2	16mA to 21mA	6.49W	175mA (typ)	Medium Power PD
3	25mA to 31mA	12.95W	375mA (typ)	Full Power PD
4	35mA to 45mA	12.95W	375mA (typ)	Reserved, Power as Class 0

*Enforced I_{CUT} active if ENFCLS pin is high. Otherwise, I_{CUT} is 375mA (typ).

APPLICATIONS INFORMATION

Power Management

The LTC4263 includes a power management feature allowing simple implementation of power management across multiple ports driven by a single power supply. The PWRMGT pins of all LTC4263 devices are tied together along with an RC network to prevent over-allocation of power in a multi-port system.

Immediately following classification, the LTC4263 performs a power management check to ensure power is available to supply the newly classed PD. The allocated power is represented by the voltage on the shared PWRMGT node and the LTC4263 checks the allocated power by measuring this voltage. If the PWRMGT voltage is less than 1V, there is power available and the power needs of the new PD are added to the already allocated power on the node. To allocate power, a current proportional to the power needs for the new PD is sourced out of the PWRMGT pin (Table 2).

Table 2. LTC4263 Power Management

IEEE 802.3af CLASS	PSE OUTPUT POWER REQUIRED	LTC4263 PWRMGT CURRENT
0, 3, 4	15.4W	-72.3μA
2	7W	-32.8μA
1	4W	-18.8μA

When additional current is added to the PWRMGT node, the voltage rises toward the 1V threshold. After adding current, the LTC4263 verifies that the power supply is not over-allocated by verifying the node voltage remains below 1V. If the voltage is below 1V, the LTC4263 proceeds to power the port. If over 1V, the current is removed from the node, port powering is aborted, and the LTC4263 goes back into detection mode.

For multiple LTC4263s implementing power management, the PWRMGT pins are connected together and to a RC network connected to V_{SS} as shown in Figure 5. The value of R_{PM} represents the full load output capability of the system power supply (P_{FULL_LOAD}). Select a 1% resistor to set the full load output power using the following formula:

$$R_{PM} = \frac{213k\Omega \cdot W}{P_{FULL_LOAD}}$$

The LTC4263 power management uses pulse width modulation to set the power requirements of each PD. Capacitor C_{PM} is used as a lowpass filter to generate the average power requirement for all PDs in the system. Set C_{PM} to 1μF.

If power management is not used, tie PWRMGT to V_{SS} .

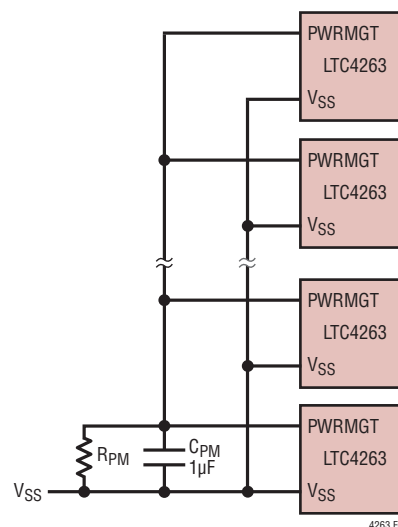

Figure 5. PWRMGT Pin Connections

APPLICATIONS INFORMATION

Power Control

The primary function of the LTC4263 is to control the delivery of power to the PSE port. In order to meet IEEE 802.3af requirements and provide a robust solution, a variety of current limit and current monitoring functions are needed, as shown in Figure 6. All control circuitry is integrated and the LTC4263 requires no external MOSFET, sense resistor, or microcontroller to achieve IEEE compliance.

The LTC4263 includes an internal MOSFET for driving the PSE port. The LTC4263 drives the gate of the internal MOSFET while monitoring the current and the output voltage at the OUT pin. This circuitry couples the 48V input supply to the port in a controlled manner that satisfies the PD's power needs while minimizing disturbances on the 48V backplane.

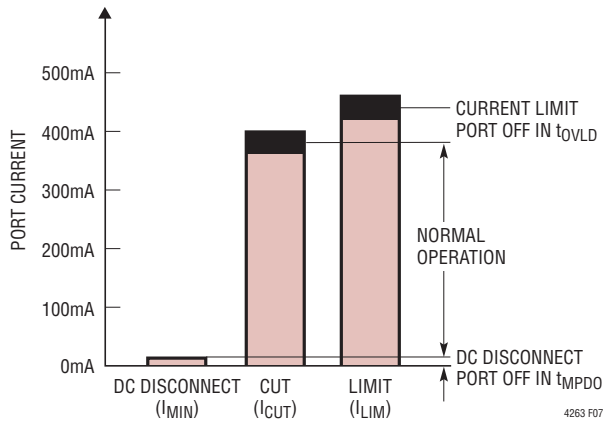

Figure 6. Current Thresholds and Current Limits

Port Overload

A PSE port is permitted to supply up to 15.4W continuously and up to 400mA (I_{CUT}) for up to 75ms ($t_{OVL D}$) when in overload. Per the IEEE 802.3af specification, the PSE is required to remove power if a port stays in an overload condition. The LTC4263 monitors port current and removes port power if port current exceeds 375mA (typ) for greater than 62ms (typ).

Port Inrush and Short-Circuit

The IEEE 802.3af standard lists two separate maximum current limits, I_{INRUSH} and I_{LIM} , that a PSE must implement.

I_{INRUSH} refers to current at port turn-on and I_{LIM} is the maximum allowable current in the case of a short after the port is powered. Because the IEEE specification calls out identical values, the LTC4263 implements both as a single current limit referred to as I_{LIM} .

When 48V power is applied to the port, the LTC4263 is designed to power-up the PD in a controlled manner without causing transients on the input supply. To accomplish this, the LTC4263 implements inrush current limit. At turn-on, current limit will allow the port voltage to quickly rise until the PD reaches its input turn-on threshold. At this point, the PD begins to draw current to charge its bypass capacitance, slowing the rate of port voltage increase.

If at any time the port is shorted or an excessive load is applied, the LTC4263 limits port current to avoid a hazardous condition. The current is limited to I_{LIM} for port voltages above 30V and is reduced for lower port voltages (see the Foldback section). Inrush and short-circuit current limit are allowed to be active for 62ms (typ) before the port is shut off.

Port Fault

If the port is suddenly shorted, the internal MOSFET power dissipation can rise to very high levels until the short-circuit current limit circuit can respond. A separate high speed current limit circuit detects severe fault conditions ($I_{OUT} > 650\text{mA}$ (typ)) and quickly turns off the internal MOSFET if such an event occurs. The circuit then limits current to I_{LIM} while the $t_{OVL D}$ timer increments. During a short-circuit, I_{LIM} will be reduced by the foldback circuitry.

$t_{OVL D}$ Timing

For overload, inrush, and short-circuit conditions, the IEEE 802.3af standard limits the duration of these events to 50ms-75ms. The LTC4263 includes a 62ms (typ) $t_{OVL D}$ timer to monitor overload conditions. The timer is incremented whenever current greater than I_{CUT} flows through the port. If the current is still above I_{CUT} when the $t_{OVL D}$ timer expires, the LTC4263 will turn off power to the port and flash the LED. In this situation, the LTC4263 waits four seconds and then restarts detection. If the overload

APPLICATIONS INFORMATION

condition is removed before the t_{QVLD} timer expires, the port stays powered and the timer is reset.

Foldback

Foldback is designed to limit power dissipation in the LTC4263 during power-up and momentary short-circuit conditions. At low port output voltages, the voltage across the internal MOSFET is high, and power dissipation will be large if significant current is flowing. Foldback monitors the port output voltage and reduces the I_{LIM} current limit level for port voltages of less than 28V, as shown in Figure 7.

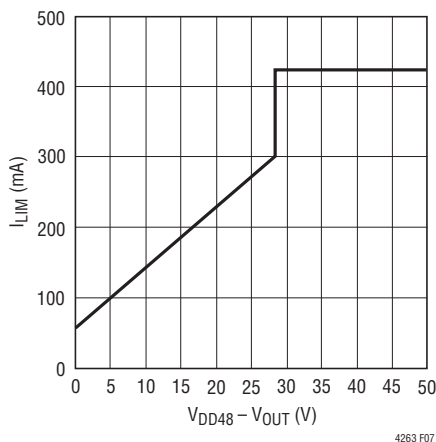

Figure 7. Current Limit Foldback

Thermal Protection

The LTC4263 includes thermal overload protection in order to provide full device functionality in a miniature package while maintaining safe operating temperatures. Several factors create the possibility for very large power dissipation within the LTC4263. At port turn-on, while I_{LIM} is active, the instantaneous power dissipated by the LTC4263 can be as high as 12W. This can cause 40°C or more of die heating in a single turn-on sequence. Similarly, excessive heating can occur if an attached PD repeatedly pushes the LTC4263 into I_{LIM} by drawing too much current. Excessive heating can also occur if the V_{DD5} pin is shorted or overloaded.

The LTC4263 protects itself from thermal damage by monitoring die temperature. If the die temperature exceeds the overtemperature trip point, the LTC4263 removes port

power and shuts down all functions including the internal 5V regulator. Once the die cools, the LTC4263 waits four seconds, then restarts detection.

DC Disconnect

The DC disconnect circuit monitors port current whenever power is on to detect continued presence of the PD. IEEE 802.3af mandates a minimum current of 10mA that the PD must draw for periods of at least 75ms with optional dropouts of no more than 250ms. The t_{MPDO} disconnect timer increments whenever port current is below 7.5mA (typ). If the timer expires, the port is turned off and the LTC4263 waits 1.5 seconds before restarting detection. If the undercurrent condition goes away before t_{MPDO} (350ms (typ)), the timer is reset to zero. The DC disconnect circuit includes a glitch filter to prevent noise from falsely resetting the timer. The current must be present for a period of at least 20ms to guarantee reset of the timer. To enable DC disconnect, tie the OSC pin to V_{SS} .

AC Disconnect

AC disconnect is an alternate method of sensing the presence or absence of a PD by monitoring the port impedance. The LTC4263 forces an AC signal from an internal sine wave generator on to the port. The ACOUT pin current is then sampled once per cycle and compared to $I_{ACD_{MIN}}$. Like DC disconnect, the AC disconnect sensing circuitry controls the t_{MPDO} disconnect timer. When the connection impedance rises due to the removal of the PD, AC peak current falls below $I_{ACD_{MIN}}$ and the disconnect timer increments. If the impedance remains high (AC peak current remains below $I_{ACD_{MIN}}$), the disconnect timer counts to t_{MPDO} and the port is turned off. If the impedance falls, causing AC peak current to rise above $I_{ACD_{MIN}}$ for two consecutive samples before the maximum count of the disconnect timer, the timer resets and the port remains powered.

The AC disconnect circuitry senses the port via the ACOUT pin. Connect a 0.47 μ F 100V X7R capacitor (C_{DET}) and a 1k Ω resistor (R_{DET}) from the DETECT pin to the port output as shown in Figure 8. This provides an AC path for sensing the port impedance. The 1k Ω resistor, R_{DET} , limits current flowing through this path during port power-on and power-off. An AC blocking diode (D_{AC}) is inserted between the OUT pin and the port to prevent the AC signal from

4263fe

APPLICATIONS INFORMATION

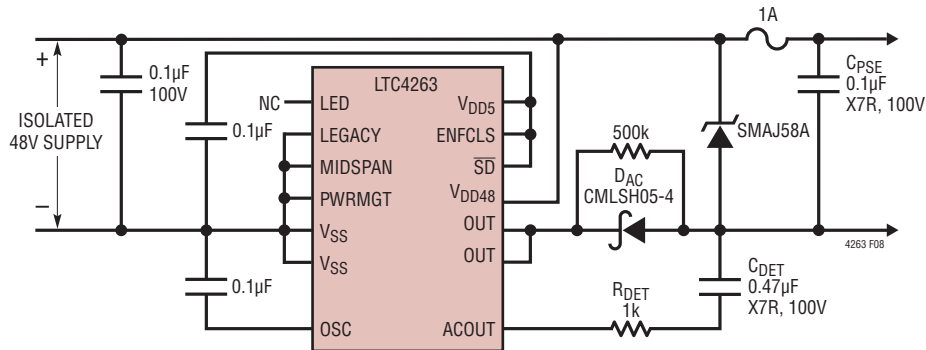

Figure 8. LTC4263 Using AC Disconnect

being shorted by the LTC4263's power control MOSFET. The 500k resistor across D_{AC} allows the port voltage to decay after disconnect occurs.

Sizing of capacitors is critical to ensure proper function of AC disconnect. C_{PSE} (Figure 8) controls the connection impedance on the PSE side. Its capacitance must be kept low enough for AC disconnect to be able to sense the PD. On the other hand, C_{DET} has to be large enough to pass the signal at 110Hz. The recommended values are 0.1µF for C_{PSE} and 0.47µF for C_{DET} . The sizes of C_{PSE} , C_{DET} , and R_{DET} are chosen to create an economical, physically compact and functionally robust system. Moreover, the complete Power over Ethernet AC disconnect system (PSE, transformers, cabling, PD, etc.) is complex; deviating from the recommended values of C_{DET} , R_{DET} and C_{PSE} is strongly discouraged. Contact the Linear Technology Applications department for additional support.

Internal 110Hz AC Oscillator

The LTC4263 includes onboard circuitry to generate a 110Hz (typ), 2V_{P-P} sine wave on its OSC pin when a 0.1µF capacitor is connected between the OSC pin and V_{SS}. This sine wave is synchronized to the controller inside the LTC4263 and should not be externally driven. Tying the OSC pin to V_{SS} shuts down the oscillator and enables DC disconnect.

Power-On Reset and Reset/Backoff Timing

Upon start-up, the LTC4263 waits four seconds before starting its first detection cycle. Depending on the results of this detection it will either power the port, repeat

detection, or wait 3.2 seconds before attempting detection again if in midspan mode.

The LTC4263 may be reset by pulling the \overline{SD} pin low. The port is turned off immediately and the LTC4263 sits idle. After \overline{SD} is released there will be a 4-second delay before the next detection cycle begins.

V_{DD5} Logic-Level Supply

The V_{DD5} supply for the LTC4263 can either be supplied externally or generated internally from the V_{DD48} supply. If supplied externally, a voltage between 4.5V and 5.5V should be applied to the V_{DD5} pin to cause the internal regulator to shut down. If V_{DD5} is to be generated internally, the voltage will be 4.4V (typ) and a 0.1µF capacitor should be connected between V_{DD5} and V_{SS}. Do not connect the internally generated V_{DD5} to anything other than a bypass capacitor and the logic control pins of the same LTC4263.

LED Flash Codes

The LTC4263 includes a multi-function LED driver to inform the user of the port status. The LED is turned on when the port is connected to a PD and power is applied. If the port is not connected or is connected to a non-powered device with a 150Ω or shorted termination, the port will not be powered and the LED will be off. For other port conditions, the LTC4263 blinks a code to communicate the status to the user as shown in Table 3. One flash indicates low signature resistance, two flashes indicates high resistance, five flashes indicates an overload fault, and nine flashes indicates that power management is preventing the port from turning on.

APPLICATIONS INFORMATION

When active, the LED flash codes are repeated every 1.2 seconds. The duration of each LED flash is 75ms. Multiple LED flashes occur at a 300ms interval.

The LTC4263 includes a feature for efficiently driving the LED from a 48V power supply without the wasted power caused by having to drop over 45V in a current limit resistor. When operating the V_{DD5} supply internally, the LTC4263 drives the LED pin with a 6% duty cycle PWM signal. This allows use of the simple LED drive circuit in Figure 9 to minimize power dissipation. The modulation frequency of the LED drive is 28kHz, making the on period

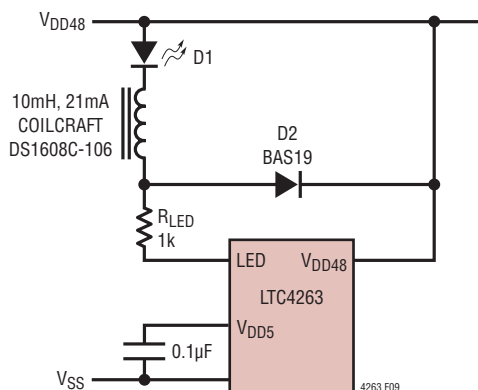

Figure 9. LED Drive Circuit with Single 48V Supply

2.2 μ s. During the 2.2 μ s that the LED pin is pulled low, current ramps up in the inductor, limited by R_{LED} . Diode D2 completes the circuit by allowing current to circulate while the LED pin is open circuit. Since current is only drawn from the power supply 6% of the time, power dissipation is substantially reduced.

When V_{DD5} is powered from an external supply, the PWM signal is disabled and the LED pin will pull down continuously when on. In this mode, the LED can be powered from the 5V supply with a simple series resistor.

IEEE 802.3af COMPLIANCE AND EXTERNAL COMPONENT SELECTION

This section discusses the other elements that go along with the LTC4263 to make an IEEE 802.3af compliant PSE. The LTC4263 is designed to control power delivery in IEEE 802.3af compliant Power Sourcing Equipment. Because proper operation of the LTC4263 also depends on external components and power sources like the 48V supply, using the LTC4263 in a PSE does not in itself guarantee IEEE 802.3af compliance. To ensure a compliant PSE design, it is recommended to adhere closely to the example application circuits provided. For further assistance contact the Linear Technology Applications department.

Table 3. Port Status and LED Flash Codes

PORT STATUS	LED FLASH CODE	FLASH PATTERN
Non-Powered Device $0\Omega < R_{PORT} < 200\Omega$	Off	LED Off
Port Open $R_{PORT} > 1M\Omega$	Off	LED Off
Port On $25k\Omega$	On	LED On
Low Signature Resistance $300\Omega < R_{PORT} < 15k\Omega$	1 Flash	☀ ● ● ● ☀ ● ● ● ☀ ● ● ●
High Signature Resistance $33k\Omega < R_{PORT} < 500k\Omega$	2 Flashes	☀ ☀ ● ● ☀ ☀ ● ● ☀ ☀ ● ●
Port Overload Fault	5 Flashes	● ● ● ● ☀ ☀ ☀ ☀ ☀ ● ● ●
Power Management Allocation Exceeded	9 Flashes	● ☀ ☀ ☀ ☀ ☀ ☀ ☀ ☀ ☀ ● ●

APPLICATIONS INFORMATION

Common Mode Chokes

Both non-powered and powered Ethernet connections achieve best performance for data transfer and EMI when a common mode choke is used on each port. For cost reduction reasons, some designs share a common mode choke between two adjacent ports. This is not recommended. Sharing a common mode choke between two ports couples start-up, disconnect and fault transients from one port to the other. The end result can range from momentary noncompliance with IEEE 802.3af to intermittent behavior and even to excessive voltages that may damage circuitry in both the PSE and PD connected to the port.

Transient Suppressor Diode

IEEE 802.3af Power over Ethernet is a challenging Hot Swap™ application because it must survive unintentional abuse by repeated plugging in and out of devices at the port. Ethernet cables could potentially be cut or shorted together. Consequently, the PSE must be designed to handle these events without damage.

The most severe of these events is a sudden short on a powered port. What the PSE sees depends on how much CAT-5 cable is between it and the short. If the short occurs on the far end of a long cable, the cable inductance will prevent the current in the cable from increasing too quickly and the LTC4263 built-in short-circuit protection will control the current and turn off the port. However, the high current along with the cable inductance causes a large flyback voltage to appear across the port when the MOSFET is turned off. In the case of a short occurring with a minimum length cable, the instantaneous current can be extremely high due to the lower inductance. The LTC4263 has a high speed fault current limit circuit that

shuts down the port in 20 μ s (typ). In this case, there is lower inductance but higher current so the event is still severe. A transient suppressor is required to clamp the port voltage and prevent damage to the LTC4263. An SMAJ58A or equivalent device works well to maintain port voltages within a safe range. A bidirectional transient suppressor should not be used. Good board layout places the transient suppressor between the port and the LTC4263 to enhance the protective function.

If the port voltage reverses polarity and goes positive, the OUT pin can be overstressed because this voltage is stacked on top of the 48V supply. In this case, the transient suppressor must clamp the voltage to a small positive value to protect the LTC4263 and the PSE capacitor.

Component leakages across the port can have an adverse affect on AC disconnect and even affect DC disconnect if the leakage becomes severe. The SMAJ58A is rated at less than 5 μ A leakage at 58V and works well in this application. There is a potential for stress induced leakage, so sufficient margins should be used when selecting transient suppressors for these applications.

Capacitors

Sizing of both the C_{DET} and C_{PSE} capacitors is critical for proper operation of the LTC4263 AC disconnect sensing. See the AC Disconnect section for more information. Note that many ceramic capacitors have dramatic DC voltage and temperature coefficients. Use 100V or higher rated X7R capacitors for C_{DET} and C_{PSE} , as these have reduced voltage dependence while also being relatively small and inexpensive. Bypass the 48V supply with a 0.1 μ F, 100V capacitor located close to the LTC4263. The V_{DD5} supply also requires a 0.1 μ F bypass capacitor.

APPLICATIONS INFORMATION

Fuse

While the LTC4263 does not require a fuse for proper operation or for compliance with IEEE 802.3af, some safety requirements state that the output current must be limited to less than 2A in less than 60 seconds if any one component fails or is shorted. Since the LTC4263 is the primary current limiter, its failure could result in excess current to the port. To meet these safety requirements, a fuse can be placed in the positive leg of the port. The fuse must be large enough that it will pass at least 450mA when derated for high temperature but small enough that it will fuse at less than 2A at cold temperature. This requirement can usually be satisfied with a 1A fuse or PTC. Placing the fuse between the RJ-45 connector and the LTC4263 and its associated circuitry provides additional protection for this circuitry. Consult a safety requirements expert for the application specific requirements.

Power Supply

Poor regulation on the 48V supply can lead to noncompliance. The IEEE specification requires a PSE output voltage between 44V and 57V. When the LTC4263 begins powering an Ethernet port, it controls the current through the port to minimize disturbances on V_{SS} . However, if the V_{SS} supply is underdamped or otherwise unstable, its voltage could go outside of the IEEE-specified limits, causing the PSE to be noncompliant. This scenario can be even worse when a PD is unplugged because the current can drop immediately to zero. In both cases the port voltage must always stay between 44V and 57V. Beyond this, the IEEE 802.3af specification places specific ripple, noise and load regulation requirements on the PSE. Disturbances on V_{SS} can also adversely affect detection, classification and AC disconnect sensing. For these reasons, proper bypassing and stability of the V_{SS} supply is important.

Another problem that can affect the V_{SS} supply is insufficient power, leading to the supply voltage dropping out of the specified range. The 802.3af specification states that if a PSE powers a PD it must be able to provide the maximum power level requested by the PD based on the PD's classification. The specification does allow a PSE to choose not to power a port, typically because the PD requires more power than the PSE has available to deliver. If a PSE is built with a V_{SS} supply not capable of delivering full power to all ports, it is recommended to use the LTC4263 power management feature to prevent ports from being turned on when there is insufficient power. Because the specification also requires the PSE to supply an inrush current of 400mA at up to a 5% duty cycle, the V_{SS} supply capability should be at least a few percent higher than the maximum total power the PSE needs to supply to the PDs.

Isolation

The IEEE 802.3af standard requires Ethernet ports to be electrically isolated from all other conductors that are user accessible. This includes the metal chassis, other connectors, and the AC power line. Environment A isolation is the most common and applies to wiring within a single building serviced by a single AC power system. For this type of application, the PSE isolation requirement can be met with the use of a single, isolated 48V supply powering several LTC4263 ports. Environment B, the stricter isolation requirement, is for networks that cross an AC power distribution boundary. In this case, electrical isolation must be maintained between each port in the PSE. The LTC4263 can be used to build a multi-port Environment B PSE by powering each LTC4263 from a separate, isolated 48V supply. In all PSE applications, there should be no user accessible connections to the LTC4263 other than the RJ-45 port.

TYPICAL APPLICATIONS

Three Port Midspan PSE with Power Management Set for 30W

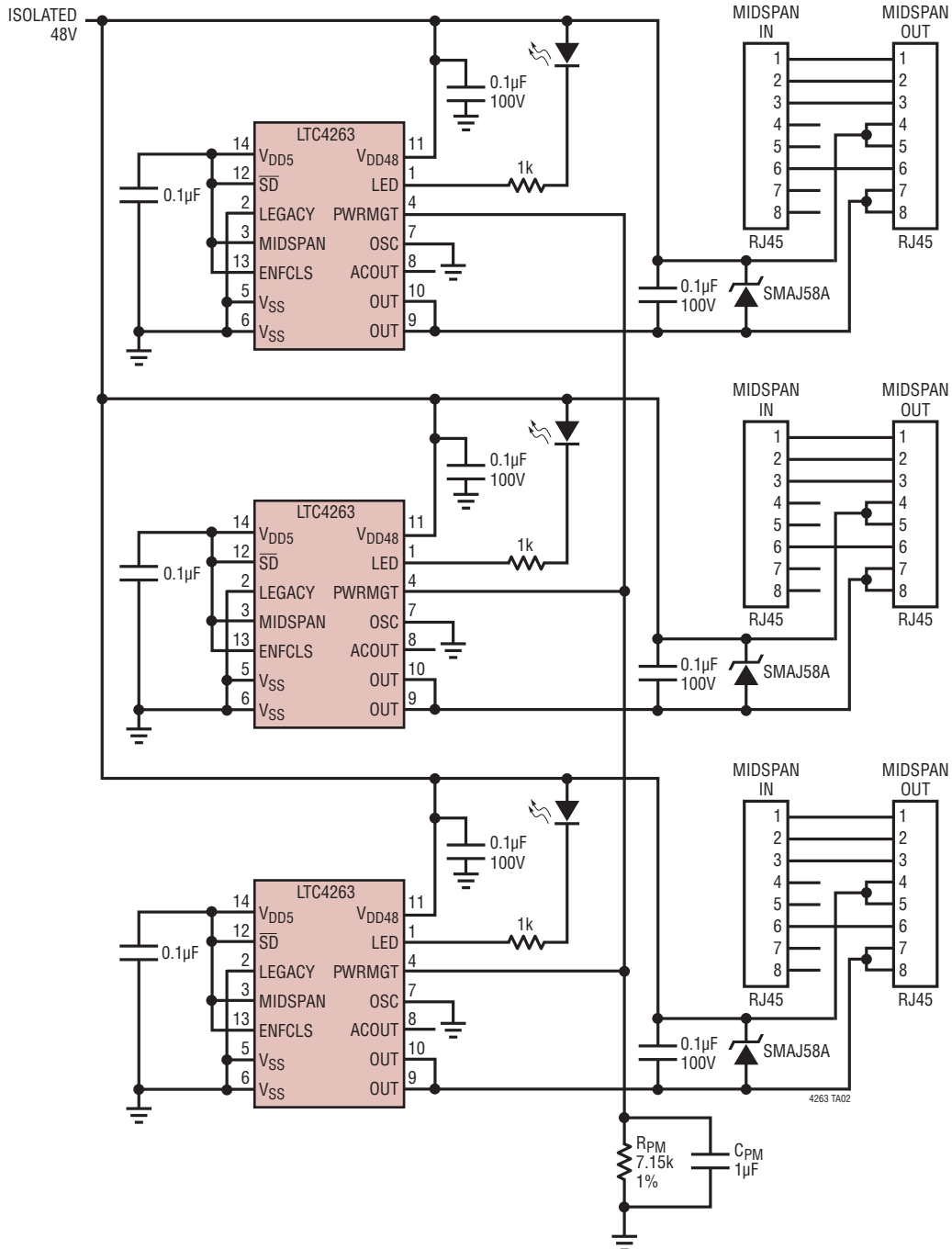

PACKAGE DESCRIPTION

DE Package 14-Lead Plastic DFN (4mm × 3mm) (Reference LTC DWG # 05-08-1708 Rev B)

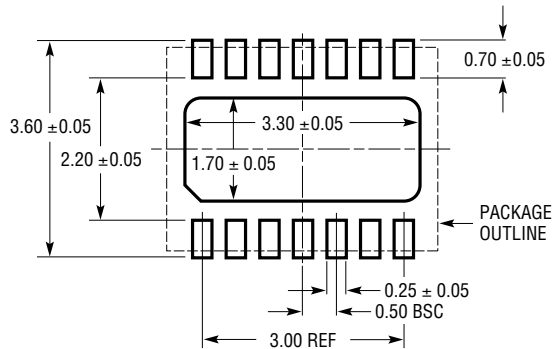

RECOMMENDED SOLDER PAD PITCH AND DIMENSIONS
APPLY SOLDER MASK TO AREAS THAT ARE NOT SOLDERED

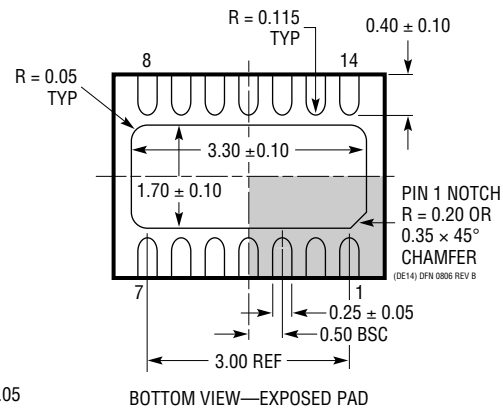
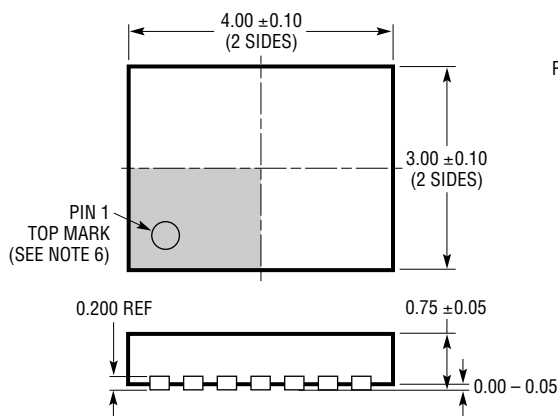

- NOTE:
1. DRAWING PROPOSED TO BE MADE VARIATION OF VERSION (WGED-3) IN JEDEC PACKAGE OUTLINE MO-229
 2. DRAWING NOT TO SCALE
 3. ALL DIMENSIONS ARE IN MILLIMETERS
 4. DIMENSIONS OF EXPOSED PAD ON BOTTOM OF PACKAGE DO NOT INCLUDE MOLD FLASH. MOLD FLASH, IF PRESENT, SHALL NOT EXCEED 0.15mm ON ANY SIDE
 5. EXPOSED PAD SHALL BE SOLDER PLATED
 6. SHADED AREA IS ONLY A REFERENCE FOR PIN 1 LOCATION ON THE TOP AND BOTTOM OF PACKAGE

PACKAGE DESCRIPTION

S Package
14-Lead Plastic Small Outline (Narrow .150 Inch)
 (Reference LTC DWG # 05-08-1610)

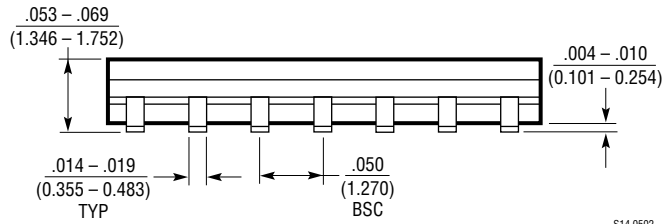
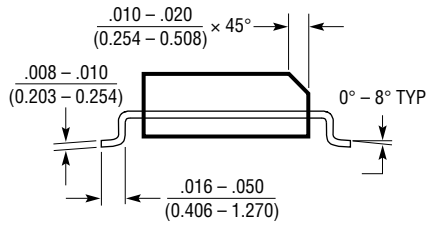
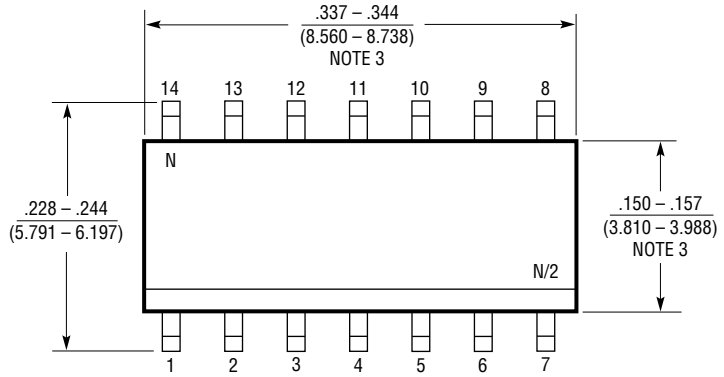
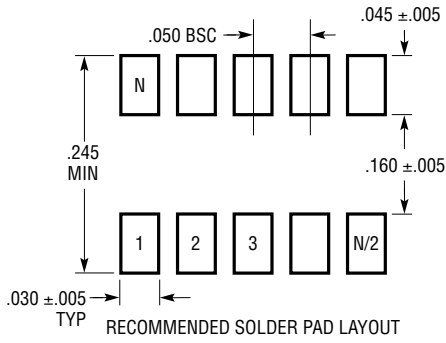

- NOTE:
 1. DIMENSIONS IN $\frac{\text{INCHES}}{\text{MILLIMETERS}}$
 2. DRAWING NOT TO SCALE
 3. THESE DIMENSIONS DO NOT INCLUDE MOLD FLASH OR PROTRUSIONS.
 MOLD FLASH OR PROTRUSIONS SHALL NOT EXCEED .006" (0.15mm)

S14 0502

REVISION HISTORY (Revision history begins at Rev E)

REV	DATE	DESCRIPTION	PAGE NUMBER
E	6/10	Replaced Figure 3 in Applications Information section	11

TYPICAL APPLICATION

Complete Single-Port Endpoint PSE with Integrated RJ45

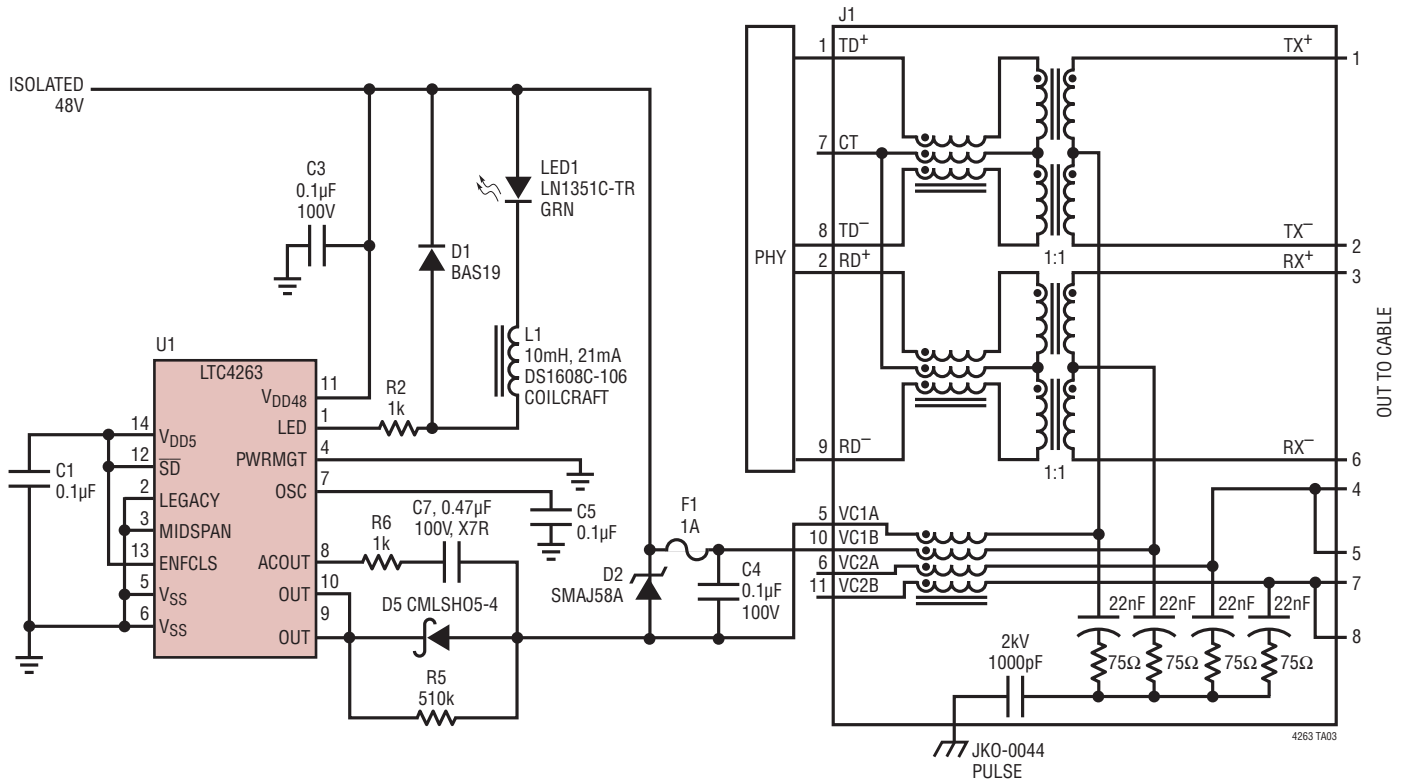

RELATED PARTS

PART NUMBER	DESCRIPTION	COMMENTS
LTC1737	High Power Isolated Flyback Controller	Sense Output Voltage Directly from Primary-Side Winding
LTC3803	Current Mode Flyback DC/DC Controller in ThinSOT™	200kHz Constant-Frequency, Adjustable Slope Compensation, Optimized for High Input Voltage Applications
LTC4257	IEEE 802.3af PD Interface Controller	100V 400mA Internal Switch, Programmable Classification
LTC4257-1	IEEE 802.3af PD Interface Controller	100V 400mA Dual Current Limit
LTC4258	Quad IEEE 802.3af Power Over Ethernet Controller	DC Disconnect Only
LTC4259A-1	Quad IEEE 802.3af Power Over Ethernet Controller	With AC Disconnect
LTC4267	IEEE 802.3af PD Interface with Switcher	Integrated Current Mode Switching Regulator

Looking for pricing, stock, or lifecycle information?

Click below to explore more details on WIN SOURCE:

 [View LTC4263CS#PBF on WIN SOURCE](#)

 [Linear Technology](#) Information

Optimize Your Supply Chain with WIN SOURCE Solutions

-  Global Sourcing Solution
-  Obsolete Management
-  Cost Control Management
-  Shortage Management
-  Alternative Solution
-  Excess Inventory Management