



**THE DATASHEET OF  
LTC4012CUF-3#TRPBF**



# High Efficiency, Multi-Chemistry Battery Charger with PowerPath Control

## FEATURES

- General Purpose Battery Charger Controller
- Efficient 550kHz Synchronous Buck PWM Topology
- $\pm 0.5\%$  Output Float Voltage Accuracy
- Programmable Charge Current: 4% Accuracy
- Programmable AC Adapter Current Limit: 3% Accuracy
- No Audible Noise with Ceramic Capacitors
- INFET Low Loss Ideal Diode PowerPath™ Control
- Wide Input Voltage Range: 6V to 28V
- Wide Output Voltage Range: 2V to 28V
- Indicator Outputs for Charging, C/10 Current Detection and Input Current Limiting
- Analog Charge Current Monitor
- Micropower Shutdown
- 20-Pin 4mm × 4mm × 0.75mm QFN Package

## APPLICATIONS

- Notebook Computers
- Portable Instruments
- Battery Backup Systems

LT, LT, LTC, LTM, Linear Technology and the Linear logo are registered trademarks and PowerPath and ThinSOT are trademarks of Linear Technology Corporation. All other trademarks are the property of their respective owners. Protected by U.S. Patents including 5723970.

## DESCRIPTION

The LTC®4012-3 is a constant-current/constant-voltage battery charger controller. It uses a synchronous quasi-constant frequency PWM control architecture that will not generate audible noise with ceramic bulk capacitors. Charge current is set by external resistors and can be monitored as an output voltage across the programming resistor. With no built-in termination, the LTC4012-3 charges a wide range of batteries under external control.

The LTC4012-3 features fully adjustable output voltage. For charge management and safety, the IC includes an input P-channel MOSFET ideal diode controller, battery (output) overvoltage protection, reverse charge current protection, PWM soft-start and robust non-overlap control for an all N-channel MOSFET PWM power stage.

The device includes AC adapter input current limiting, which maximizes the charge rate for a fixed input power level. An external sense resistor programs the input current limit, and the  $\overline{\text{ICL}}$  status pin indicates reduced charge current as a result of AC adapter current limiting. Ideal diode control at the adaptor input improves charger efficiency.

The  $\overline{\text{CHRG}}$  status pin is active during all charging modes, including special indication for low charge current.

## TYPICAL APPLICATION

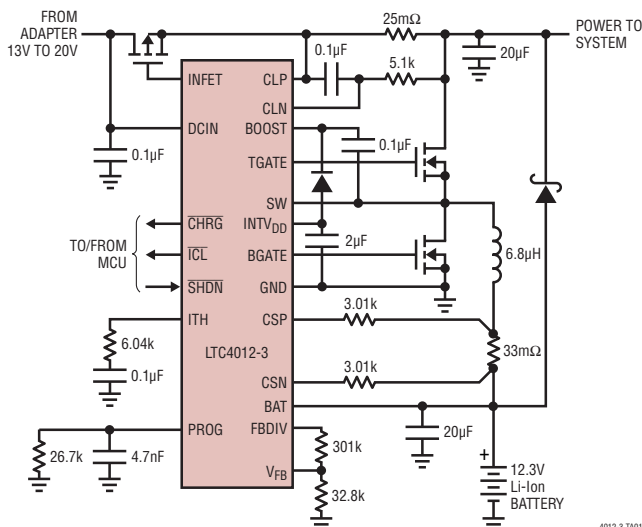

Efficiency at DCIN = 20V

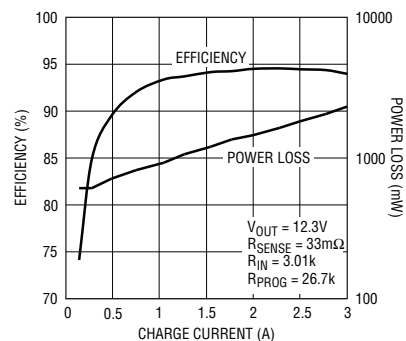

PIN 5 NAME		
PART	GND	ACP
LTC4012		X
LTC4012-3	X	

4012-3 TA02

4012-3 TA01

40123fb

# LTC4012-3

## ABSOLUTE MAXIMUM RATINGS

(Note 1)

DCIN .....	-14V to 30V
DCIN to CLP .....	-32V to 20V
CLP, CLN or SW to GND .....	-0.3V to 30V
CLP to CLN .....	±0.3V
CSP, CSN or BAT to GND .....	-0.3V to 28V
CSP to CSN .....	±0.3V
BOOST to GND .....	-0.3V to 36V
BOOST to SW .....	-0.3V to 7V
SHDN or $V_{FB}$ to GND .....	-0.3V to 7V
CHRG or $\overline{ICL}$ to GND .....	-0.3V to 30V
Operating Temperature Range	
(Note 2) .....	-40°C to 125°C
Junction Temperature (Note 3) .....	125°C
Storage Temperature Range .....	-65°C to 150°C

## PIN CONFIGURATION

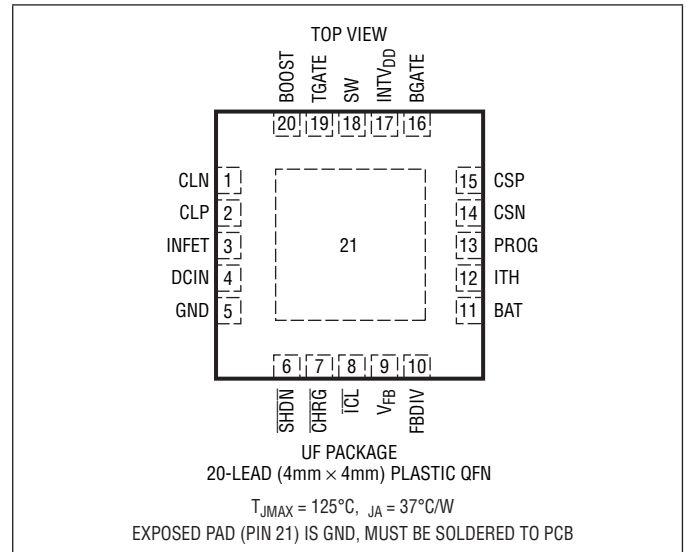

## ORDER INFORMATION

LEAD FREE FINISH	TAPE AND REEL	PART MARKING*	PACKAGE DESCRIPTION	TEMPERATURE RANGE
LTC4012CUF-3#PBF	LTC4012CUF-3#TRPBF	40123	20-Lead (4mm × 4mm) Plastic QFN	0°C to 85°C
LTC4012IUF-3#PBF	LTC4012IUF-3#TRPBF	40123	20-Lead (4mm × 4mm) Plastic QFN	-40°C to 125°C

Consult LTC Marketing for parts specified with wider operating temperature ranges. \*The temperature grade is identified by a label on the shipping container. Consult LTC Marketing for information on non-standard lead based finish parts.

For more information on lead free part marking, go to: <http://www.linear.com/leadfree/>

For more information on tape and reel specifications, go to: <http://www.linear.com/tapeandreel/>

## ELECTRICAL CHARACTERISTICS

The ● denotes the specifications which apply over the full operating temperature range, otherwise specifications are at  $T_A = 25^\circ\text{C}$ .  $\text{DCIN} = 20\text{V}$ ,  $\text{BAT} = 12\text{V}$ ,  $\text{GND} = 0\text{V}$  unless otherwise noted. (Note 2)

SYMBOL	PARAMETER	CONDITIONS	MIN	TYP	MAX	UNITS	
<b>Charge Voltage Regulation</b>							
$V_{\text{TOL}}$	$V_{\text{BAT}}$ Accuracy (See Test Circuits)	C-Grade	●	-0.5	0.5	%	
		I-Grade	●	-0.8	0.8	%	
				-1.0	1.0	%	
$I_{\text{VFB}}$	$V_{\text{FB}}$ Input Bias Current	$V_{\text{FB}} = 1.2\text{V}$		±20		nA	
$R_{\text{ON}}$	FBDIV On Resistance	$I_{\text{LOAD}} = 100\mu\text{A}$	●	85	190	$\Omega$	
$I_{\text{LEAK-FBDIV}}$	FBDIV Output Leakage Current	$\text{SHDN} = 0\text{V}$ , $\text{FBDIV} = 0\text{V}$	●	-1	0	1	$\mu\text{A}$
$V_{\text{BOV}}$	$V_{\text{FB}}$ Overvoltage Threshold		●	1.235	1.281	1.32	V
<b>Charge Current Regulation</b>							
$I_{\text{TOL}}$	Charge Current Accuracy with $R_{\text{IN}} = 3.01\text{k}$ , $6\text{V} < \text{BAT} < 18\text{V}$	$R_{\text{PROG}} = 26.7\text{k}$	●	-4	4	%	
		C-Grade	●	-5	5	%	
		I-Grade	●	-9.5	9.5	%	
		$V_{\text{SENSE}} = 0\text{mV}$ , $\text{PROG} = 1.2\text{V}$		-12.75	-11.67	-10.95	$\mu\text{A}$
$A_{\text{I}}$	Current Sense Amplifier Gain (PROG $\Delta I$ ) with $R_{\text{IN}} = 3.01\text{k}$ , $6\text{V} < \text{BAT} < 18\text{V}$	$V_{\text{SENSE}}$ Step from $0\text{mV}$ to $5\text{mV}$ , $\text{PROG} = 1.2\text{V}$		-1.78	-1.66	-1.54	$\mu\text{A}$
$V_{\text{CS-MAX}}$	Maximum Peak Current Sense Threshold Voltage per Cycle ( $R_{\text{IN}} = 3.01\text{k}$ )	ITH = 2V, C-Grade	●	140	195	250	mV
		ITH = 2V, I-Grade	●	125		265	mV
		ITH = 5V	●		325	430	mV
$V_{\text{C10}}$	C/10 Indicator Threshold Voltage	PROG Falling		340	400	460	mV
$V_{\text{REV}}$	Reverse Current Threshold Voltage	PROG Falling		180	253	295	mV
<b>Input Current Regulation</b>							
$V_{\text{CL}}$	Current Limit Threshold	CLP – CLN		97	100	103	mV
		C-Grade	●	96	100	104	mV
		I-Grade	●	92		108	mV
$I_{\text{CLN}}$	CLN Input Bias Current	CLN = CLP		±100		nA	
$V_{\text{ICL}}$	ICL Indicator Threshold	(CLP – CLN) – $V_{\text{CL}}$		-8	-5	-2	mV
<b>CLP Supply</b>							
OVR	Operating Voltage Range			6	28	V	
$V_{\text{UVLO}}$	CLP Undervoltage Lockout Threshold	CLP Increasing	●	4.65	4.85	5.25	V
$V_{\text{UV(HYST)}}$	UVLO Threshold Hysteresis			200		mV	
$I_{\text{CLPO}}$	CLP Operating Current	CLP = 20V, No Gate Loads			2	3	mA
<b>Shutdown</b>							
$V_{\text{IL}}$	SHDN Input Voltage Low		●		300	mV	
$V_{\text{IH}}$	SHDN Input Voltage High		●	1.4		V	
$R_{\text{IN}}$	SHDN Pull-Down Resistance			40		k $\Omega$	
$I_{\text{CLPS}}$	CLP Shutdown Current	CLP = 12V, DCIN = 0V	●		15	26	$\mu\text{A}$
		SHDN = 0V			350	500	$\mu\text{A}$
$I_{\text{LEAK-BAT}}$	BAT Leakage Current	SHDN = 0V or DCIN = 0V, $0\text{V} \leq \text{CSP} = \text{CSN} = \text{BAT} \leq 18\text{V}$	●	-1.5	0	1.5	$\mu\text{A}$
$I_{\text{LEAK-CSN}}$	CSN Leakage Current	SHDN = 0V or DCIN = 0V, $0\text{V} \leq \text{CSP} = \text{CSN} = \text{BAT} \leq 20\text{V}$	●	-1.5	0	1.5	$\mu\text{A}$
$I_{\text{LEAK-CSP}}$	CSP Leakage Current	SHDN = 0V or DCIN = 0V, $0\text{V} \leq \text{CSP} = \text{CSN} = \text{BAT} \leq 20\text{V}$	●	-1.5	0	1.5	$\mu\text{A}$
$I_{\text{LEAK-SW}}$	SW Leakage Current	SHDN = 0V or DCIN = 0V, $0\text{V} \leq \text{SW} \leq 20\text{V}$	●	-1	0	2	$\mu\text{A}$

## ELECTRICAL CHARACTERISTICS

The ● denotes the specifications which apply over the full operating temperature range, otherwise specifications are at  $T_A = 25^\circ\text{C}$ .  $\text{DCIN} = 20\text{V}$ ,  $\text{BAT} = 12\text{V}$ ,  $\text{GND} = 0\text{V}$  unless otherwise noted. (Note 2)

SYMBOL	PARAMETER	CONDITIONS		MIN	TYP	MAX	UNITS
<b>INTV<sub>DD</sub> Regulator</b>							
INTV <sub>DD</sub>	Output Voltage	No Load	●	4.85	5	5.15	V
$\Delta V_{\text{DD}}$	Load Regulation	$I_{\text{DD}} = 20\text{mA}$			-0.4	-1	%
$I_{\text{DD}}$	Short-Circuit Current (Note 5)	INTV <sub>DD</sub> = 0V		50	85	130	mA
<b>Switching Regulator</b>							
$V_{\text{ACP}}$	AC Present Charge Enable Threshold Voltage	DCIN – BAT, DCIN Rising C-Grade I-Grade	● ●	350 300	500	650 700	mV mV
$I_{\text{ITH}}$	ITH Current	ITH = 1.4V			-40/+90		$\mu\text{A}$
$f_{\text{TYP}}$	Typical Switching Frequency			467	550	633	kHz
$f_{\text{MIN}}$	Minimum Switching Frequency	$C_{\text{LOAD}} = 3.3\text{nF}$		20	25		kHz
$\text{DC}_{\text{MAX}}$	Maximum Duty Cycle	$C_{\text{LOAD}} = 3.3\text{nF}$		98	99		%
$t_{\text{R-TG}}$	TGATE Rise Time	$C_{\text{LOAD}} = 3.3\text{nF}$ , 10% – 90%			60	110	ns
$t_{\text{F-TG}}$	TGATE Fall Time	$C_{\text{LOAD}} = 3.3\text{nF}$ , 90% – 10%			50	110	ns
$t_{\text{R-BG}}$	BGATE Rise Time	$C_{\text{LOAD}} = 3.3\text{nF}$ , 10% – 90%			60	110	ns
$t_{\text{F-BG}}$	BGATE Fall Time	$C_{\text{LOAD}} = 3.3\text{nF}$ , 90% – 10%			60	110	ns
$t_{\text{NO}}$	TGATE, BGATE Non-Overlap Time	$C_{\text{LOAD}} = 3.3\text{nF}$ , 10% – 10%			110		ns
<b>PowerPath Control</b>							
$I_{\text{DCIN}}$	DCIN Input Current	$0\text{V} \leq \text{DCIN} \leq \text{CLP}$	●	-10		60	$\mu\text{A}$
$V_{\text{FTO}}$	Forward Turn-On Voltage (DCIN Detection Threshold)	DCIN-CLP, DCIN Rising	●	15		60	mV
$V_{\text{FR}}$	Forward Regulation Voltage	DCIN-CLP	●	15	25	35	mV
$V_{\text{RTO}}$	Reverse Turn-Off Voltage	DCIN-CLP, DCIN Falling	●	-45	-25	-15	mV
$V_{\text{OL(INFET)}}$	INFET Output Low Voltage, Relative to CLP	DCIN-CLP = 0.1V, $I_{\text{INFET}} = 1\mu\text{A}$		-6.5		-5	V
$V_{\text{OH(INFET)}}$	INFET Output High Voltage, Relative to CLP	DCIN-CLP = -0.1V, $I_{\text{INFET}} = -5\mu\text{A}$		-250		250	mV
$t_{\text{F(ON)}}$	INFET Turn-On Time	To CLP-INFET > 3V, $C_{\text{INFET}} = 1\text{nF}$			85	180	$\mu\text{s}$
$t_{\text{F(OFF)}}$	INFET Turn-Off Time	To CLP-INFET < 1.5V, $C_{\text{INFET}} = 1\text{nF}$			2.5	6	$\mu\text{s}$
<b>Indicator Outputs</b>							
$V_{\text{OL}}$	Output Voltage Low	$I_{\text{LOAD}} = 100\mu\text{A}$ , PROG = 1.2V				500	mV
$I_{\text{LEAK}}$	Output Leakage	$\overline{\text{SHDN}} = 0\text{V}$ , DCIN = 0V, $V_{\text{OUT}} = 20\text{V}$	●	-10		10	$\mu\text{A}$
$I_{\text{C10}}$	CHRG C/10 Current Sink	CHRG = 2.5V	●	15	25	38	$\mu\text{A}$

**Note 1:** Stresses beyond those listed under Absolute Maximum Ratings may cause permanent damage to the device. Exposure to any Absolute Maximum Rating condition for extended periods may affect device reliability and lifetime.

**Note 2:** The LTC4012C-3 is guaranteed to meet performance specifications over the  $0^\circ\text{C}$  to  $85^\circ\text{C}$  operating temperature range. The LTC4012I-3 is guaranteed to meet performance specifications over the  $-40^\circ\text{C}$  to  $125^\circ\text{C}$  operating temperature range.

**Note 3:** Operating junction temperature  $T_J$  (in  $^\circ\text{C}$ ) is calculated from the ambient temperature  $T_A$  and the total continuous package power dissipation  $P_D$  (in watts) by the formula  $T_J = T_A + (\theta_{JA} \cdot P_D)$ . Refer to the Applications Information section for details.

**Note 4:** All currents into device pins are positive; all currents out of device pins are negative. All voltages are referenced to GND, unless otherwise specified.

**Note 5:** Output current may be limited by internal power dissipation. Refer to the Applications Information section for details.

# TYPICAL PERFORMANCE CHARACTERISTICS

( $T_A = 25^\circ\text{C}$  unless otherwise noted.  $L = \text{IHLP-2525 } 6.8\mu\text{H}$ )

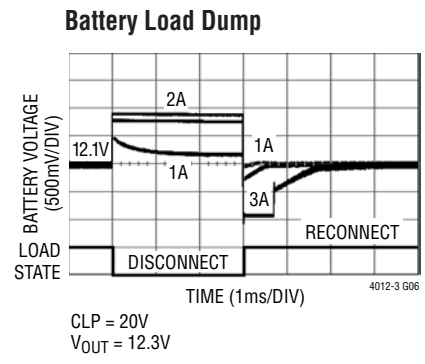
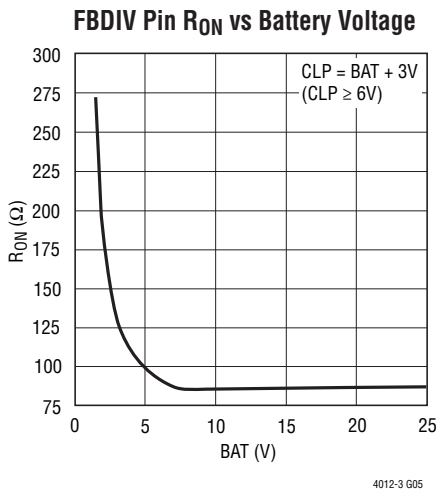
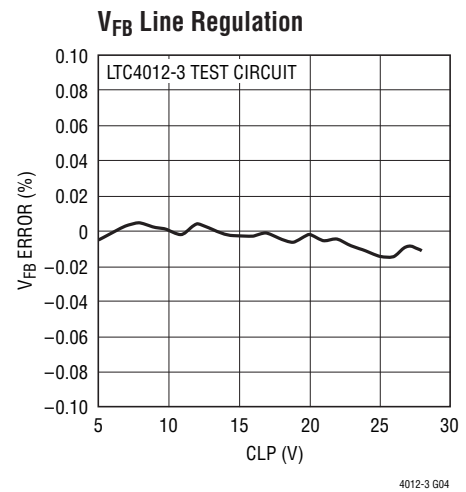
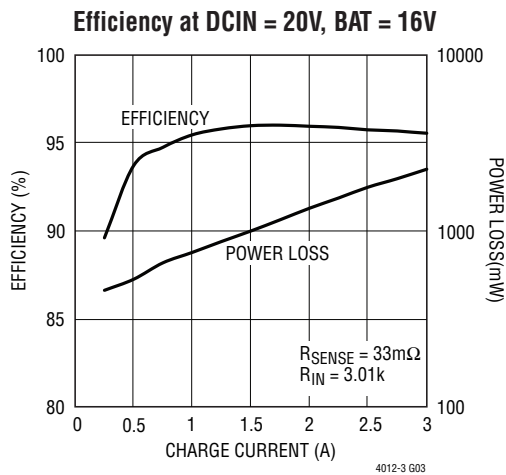
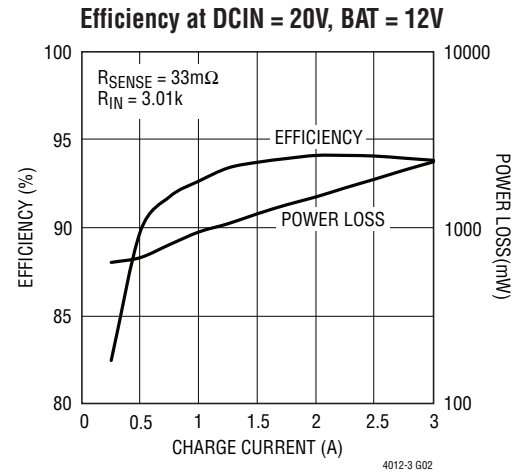
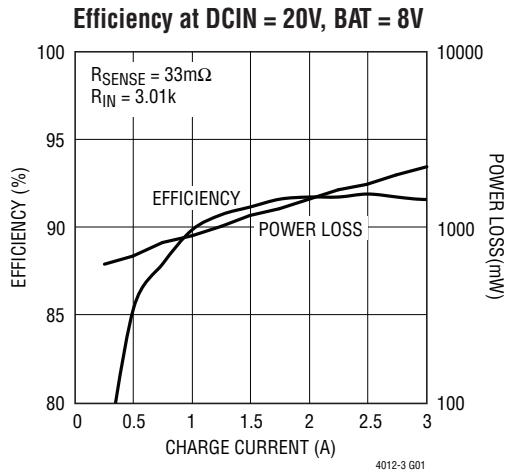

## TYPICAL PERFORMANCE CHARACTERISTICS

( $T_A = 25^\circ\text{C}$  unless otherwise noted.  $L = \text{IHLP-2525 } 6.8\mu\text{H}$ )

### Charge Current Accuracy

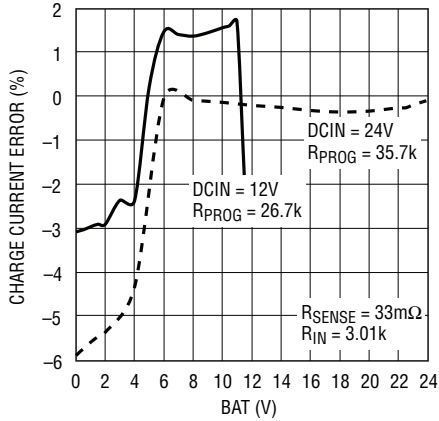

4012-3 G07

### Charge Current Line Regulation

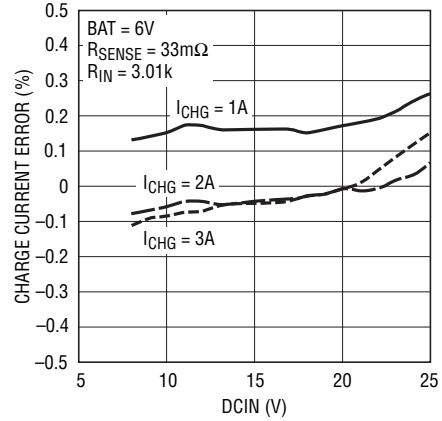

4012-3 G08

### Charge Current Load Regulation

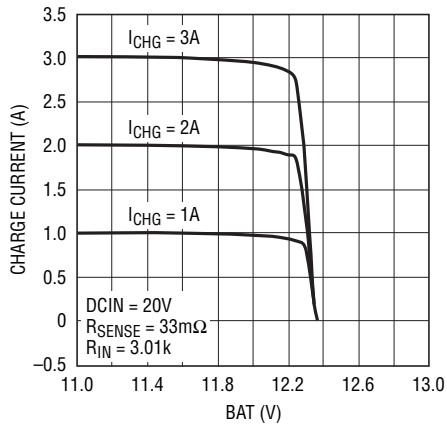

4012-3 G09

### Input Current Limit

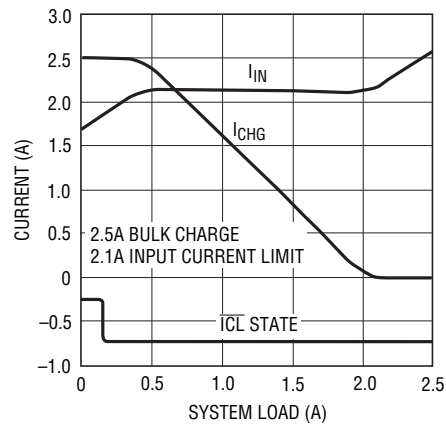

4012-3 G10

### PWM Soft-Start

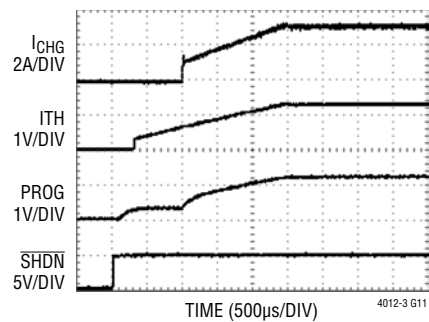

4012-3 G11

### Gate Drive Non-Overlap

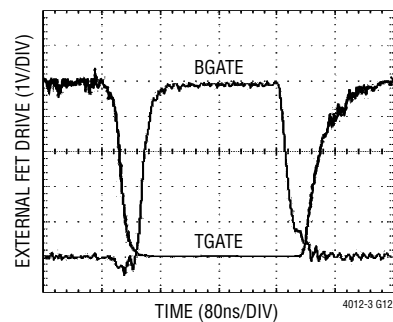

4012-3 G12

# TYPICAL PERFORMANCE CHARACTERISTICS

( $T_A = 25^\circ\text{C}$  unless otherwise noted.  $L = \text{IHLP-2525 } 6.8\mu\text{H}$ )

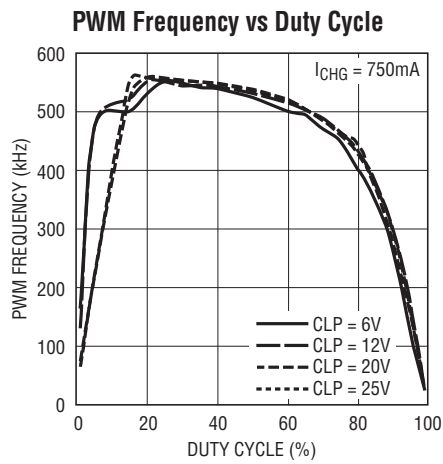

4012-3 G13

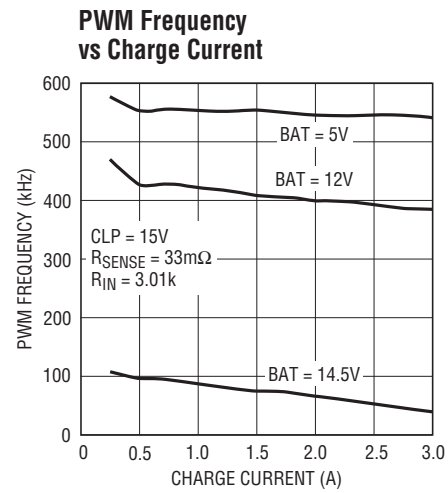

4012-3 G14

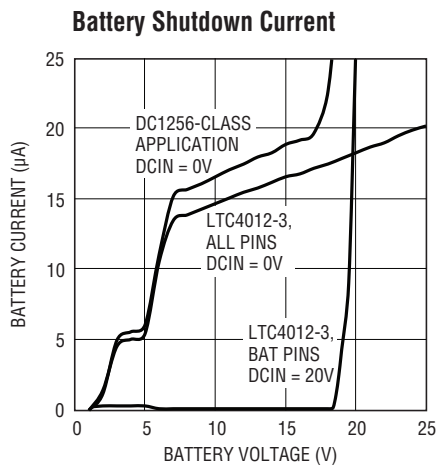

4012-3 G15

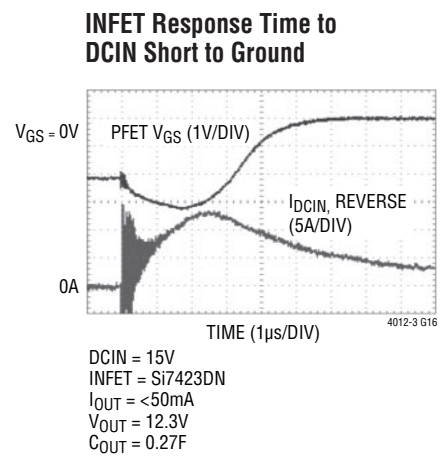

4012-3 G16

## PIN FUNCTIONS

**CLN (Pin 1):** Adapter Input Current Limit Negative Input. The LTC4012-3 senses voltage on this pin to determine if less charge current should be sourced to limit total input current. The threshold is set 100mV below the CLP pin. An external filter should be used to remove switching noise. This input should be tied to CLP if not used. Operating voltage range is (CLP – 110mV) to CLP.

**CLP (Pin 2):** Adapter Input Current Limit Positive Input. The LTC4012-3 also draws power from this pin, including a small amount for some shutdown functions. Operating voltage range is GND to 28V.

**INFET (Pin 3):** PowerPath Control Output. This output drives the gate of a PMOS pass transistor connected between the DC input (DCIN) and the raw system supply rail (CLP) to maintain a forward voltage of 25mV when a DC input source is present. INFET is internally clamped about 6V below CLP. Maximum operating voltage is CLP, which is used to turn off the input PMOS transistor when the DC input is removed.

**DCIN (Pin 4):** DC Sense Input. One of two voltage sense inputs to the internal PowerPath controller (the other input to the controller is CLP). This input is usually supplied from an input DC power source. Operating voltage ranges from GND to 28.2V.

**GND (Pin 5):** Ground. Internally connected to the Exposed Pad (package paddle).

**SHDN (Pin 6):** Active-Low Shutdown Input. Driving  $\overline{\text{SHDN}}$  below 300mV unconditionally forces the LTC4012-3 into the shutdown state. This input has a 40k $\Omega$  internal pull-down to GND. Operating voltage range is GND to INTV<sub>DD</sub>.

**CHRG (Pin 7):** Active-Low Charge Indicator Output. This open-drain output provides three levels of information about charge status using a strong pull-down, 25 $\mu$ A weak pull-down or high impedance. Refer to the Operation and Applications Information sections for further details. This output should be left floating if not used.

**$\overline{\text{ICL}}$  (Pin 8):** Active-Low Input Current Limit Indicator Output. This open-drain output pulls to GND when the charge current is reduced because of AC adapter input current limiting. This output should be left floating if not used.

**V<sub>FB</sub> (Pin 9):** Battery Voltage Feedback Input. An external resistor divider between FBDIV and GND with the center tap connected to V<sub>FB</sub> programs the charger output voltage. In constant voltage mode, this pin is nominally at 1.2085V. Refer to the Applications Information section for complete details on programming battery voltage. Operating voltage range is GND to 1.25V.

**FBDIV (Pin 10):** Battery Voltage Feedback Resistor Divider Source. The LTC4012-3 connects this pin to BAT when charging is in progress. FBDIV is an open-drain PFET output to BAT with an operating voltage range of GND to BAT.

**BAT (Pin 11):** Battery Pack Connection. The LTC4012-3 uses the voltage on this pin to control PWM operation when charging. Operating voltage range is GND to CLN.

**ITH (Pin 12):** PWM Control Voltage and Compensation Node. The LTC4012-3 develops a voltage on this pin to control cycle-by-cycle peak inductor current. An external R-C network connected to ITH provides PWM loop compensation. Refer to the Applications Information section for further details on establishing loop stability. Operating voltage range is GND to INTV<sub>DD</sub>.

**PROG (Pin 13):** Charge Current Programming and Monitoring Pin. An external resistance connected between PROG and GND, along with the current sense and PWM input resistors, programs the maximum charge current. The voltage on this pin can also provide a linearized indicator of charge current. Refer to the Applications Information section for complete details on current programming and monitoring. Operating voltage range is GND to INTV<sub>DD</sub>.

**CSN (Pin 14):** Charge Current Sense Negative Input. Place an external input resistor (R<sub>IN</sub>, Figure 1) between this pin and the negative side of the charge current sense resistor. Operating voltage ranges from (BAT – 50mV) to (BAT + 200mV).

**CSP (Pin 15):** Charge Current Sense Positive Input. Place an external input resistor (R<sub>IN</sub>, Figure 1) between this pin and the positive side of the charge current sense resistor. Operating voltage ranges from (BAT – 50mV) to (BAT + 200mV).

## PIN FUNCTIONS

**BGATE (Pin 16):** External Synchronous NFET Gate Control Output. This output provides gate drive to an external NMOS power transistor switch used for synchronous rectification to increase efficiency in the step-down DC/DC converter. Operating voltage is GND to  $INTV_{DD}$ . BGATE should be left floating if not used.

**INTV<sub>DD</sub> (Pin 17):** Internal 5V Regulator Output. This pin provides a means of bypassing the internal 5V regulator used to power the LTC4012-3 PWM FET drivers. This supply shuts down when the LTC4012-3 shuts down. Refer to the Application Information section for details if additional power is drawn from this pin by the application circuit.

**SW (Pin 18):** PWM Switch Node. The LTC4012-3 uses the voltage on this pin as the source reference for its topside NFET (PWM switch) driver. Refer to the Applications Information section for additional PCB layout suggestions related to this critical circuit node. Operating voltage range is GND to CLN.

**TGATE (Pin 19):** External NFET Switch Gate Control Output. This output provides gate drive to an external NMOS power transistor switch used in the DC/DC converter. Operating voltage range is GND to  $(CLN + 5V)$ .

**BOOST (Pin 20):** TGATE Driver Supply Input. A bootstrap capacitor is returned to this pin from a charge network connected to SW and  $INTV_{DD}$ . Refer to the Applications Information section for complete details on circuit topology and component values. Operating voltage ranges from  $(INTV_{DD} - 1V)$  to  $(CLN + 5V)$ .

**GND (Exposed Pad Pin 21):** Ground. The package paddle provides a single-point ground for the internal voltage reference and other critical LTC4012-3 circuits. It should be soldered to a suitable PCB copper ground pad for proper electrical operation and to obtain the specified package thermal resistance.

## BLOCK DIAGRAM

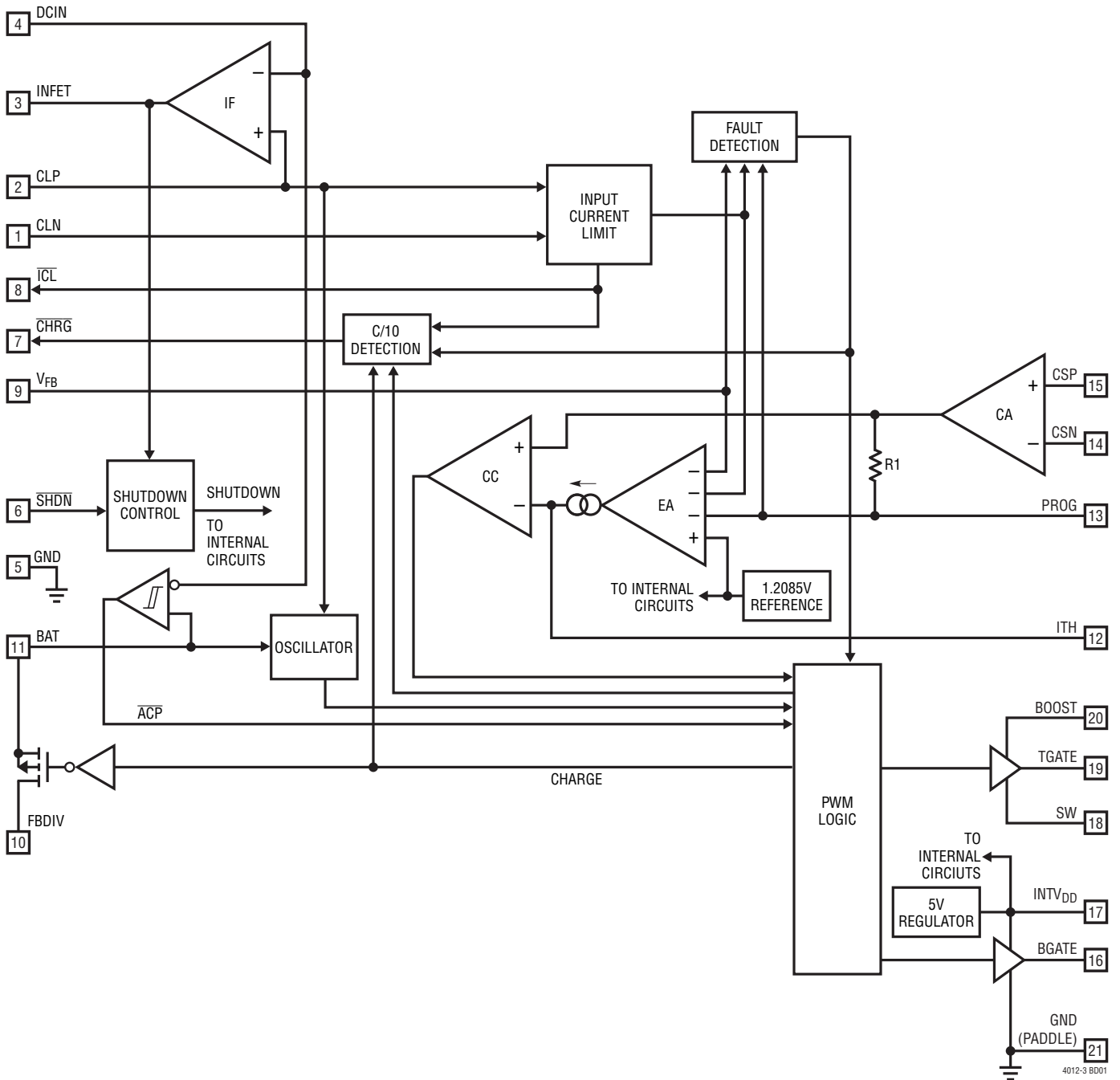

## TEST CIRCUITS

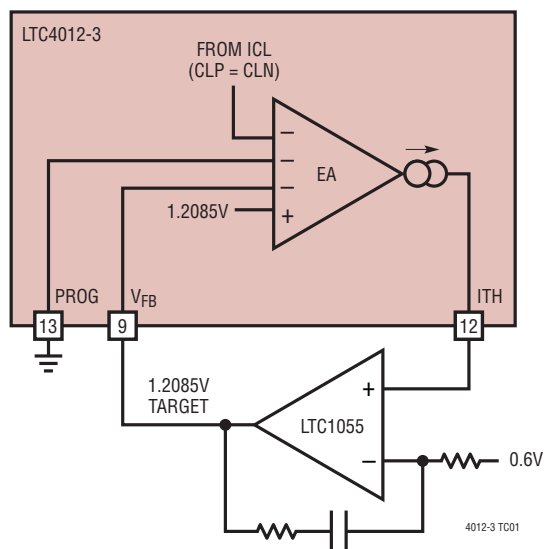

## OPERATION

### Overview

The LTC4012-3 is a synchronous step-down (buck) current mode PWM battery charger controller. The maximum charge current is programmed by the combination of a charge current sense resistor ( $R_{SENSE}$ ), matched input resistors ( $R_{IN}$ , Figure 1), and a programming resistor ( $R_{PROG}$ ) between the PROG and GND pins. Battery voltage is programmed with an external resistor divider between FBDIV and GND. In addition, the PROG pin provides a linearized voltage output of the actual charge current.

The LTC4012-3 does not have built-in charge termination and is flexible enough for charging any type of battery chemistry. It is a building block IC intended for use with an external circuit, such as a microcontroller, capable of managing the entire algorithm required for the specific battery being charged. The LTC4012-3 features a shutdown input and various state indicator outputs, allowing easy and direct management by a wide range of external (digital) charge controllers.

### Shutdown

The LTC4012-3 remains in shutdown until  $DCIN$  is greater than 5.1V and exceeds  $CLP$  by 60mV and  $\overline{SHDN}$  is driven above 1.4V. In shutdown, current drain from the battery is reduced to the lowest possible level, thereby increasing standby time. When in shutdown, the ITH pin is pulled to GND and  $\overline{CHRG}$ ,  $\overline{ICL}$ , FET gate drivers and  $INTV_{DD}$  are all disabled. Charging can be stopped at any time by forcing  $\overline{SHDN}$  below 300mV.

### AC Present Detection

AC present is detected as soon as  $DCIN$  exceeds  $BAT$  by at least 500mV. Charging is not enabled until this condition is first met. After this event, charging is no longer gated by AC present detection. If battery voltage rises due to ESR, or  $DCIN$  droops due to current load, the PWM will remain enabled, even with very low input overhead, unless  $DCIN$  falls below the supply voltage on  $CLP$ .

### Input PowerPath Control

The input PFET controller performs many important functions. First, it monitors  $DCIN$  and enables the charger when this input voltage is higher than the raw  $CLP$  system supply. Next, it controls the gate of an external input power PFET to maintain a low forward voltage drop when charging, creating improved efficiency. It also prevents reverse current flow through this same PFET, providing a suitable input blocking function. Finally, it helps avoid synchronous boost operation during invalid operating conditions by detecting elevated  $CLP$  voltage and forcing the charger off.

If  $DCIN$  voltage is less than  $CLP$ , then  $DCIN$  must rise 60mV higher than  $CLP$  to enable the charger and activate the ideal diode control. The gate of the input PFET is driven to a voltage sufficient to regulate a forward drop between  $DCIN$  and  $CLP$  of about 25mV. If the input voltage differential drops below this point, the FET is turned off slowly. If the voltage between  $DCIN$  and  $CLP$  drops to less than -25mV, the input FET is turned off in less than 6 $\mu$ s to prevent significant reverse current from flowing back through the PFET, and the charger is disabled.

### Soft-Start

Exiting the shutdown state enables the charger and releases the ITH pin. When enabled, switching will not begin until  $DCIN$  exceeds  $BAT$  by 500mV and ITH exceeds a threshold that assures initial current will be positive (about 5% to 25% of the maximum programmed current). To limit inrush current, soft-start delay is created with the compensation values used on the ITH pin. Longer soft-start times can be realized by increasing the filter capacitor on ITH, if reduced loop bandwidth is acceptable. The actual charge current at the end of soft-start will depend on which loop (current, voltage or adapter limit) is in control of the PWM. If this current is below that required by the ITH start-up threshold, the resulting charge current transient duration depends on loop compensation but is typically less than 100 $\mu$ s.

## OPERATION

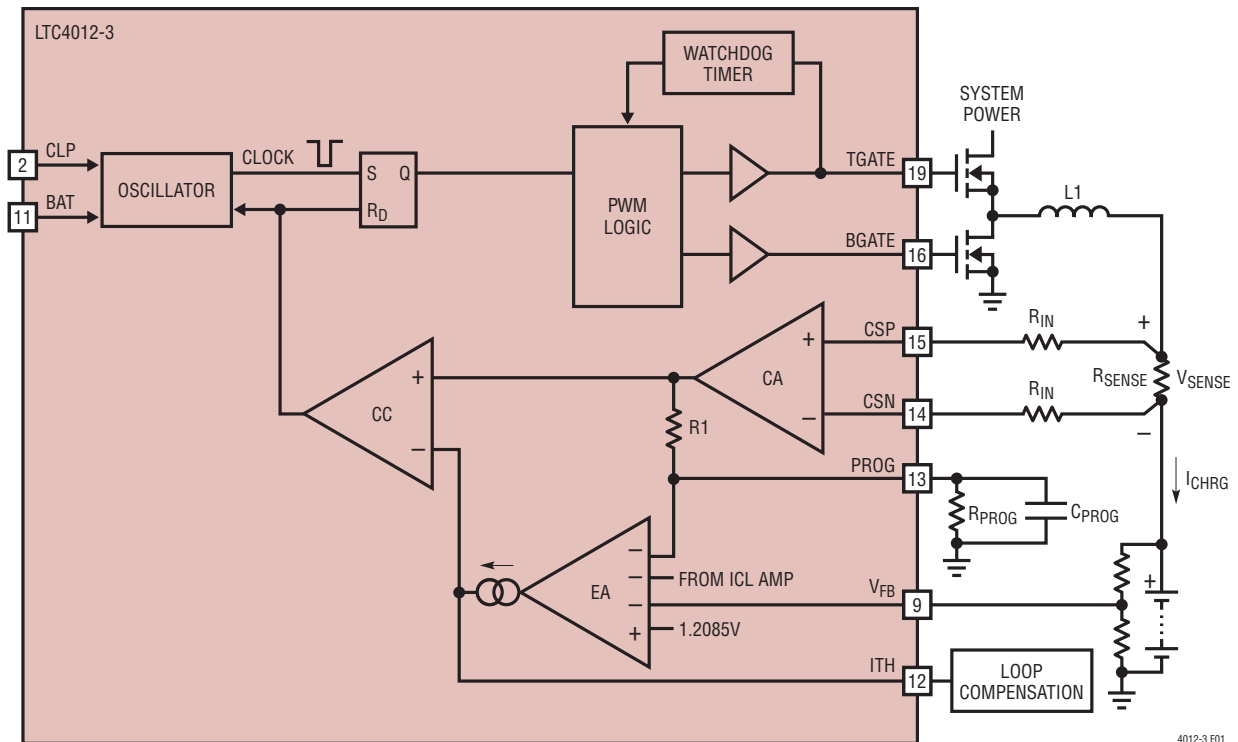

Figure 1. PWM Circuit Diagram

### Bulk Charge

When soft-start is complete, the LTC4012-3 begins sourcing the current programmed by the external components connected to CSP, CSN and PROG. Some batteries may require a small conditioning trickle current if they are heavily discharged. As shown in the Applications Information section, the LTC4012-3 can address this need through a variety of low current circuit techniques on the PROG pin. Once a suitable cell voltage has been reached, charge current can be switched to a higher, bulk charge value.

### End of Charge and $\overline{\text{CHRG}}$ Output

As the battery approaches the programmed output voltage, charge current will begin to decrease. The open-drain  $\overline{\text{CHRG}}$  output can indicate when the current drops to 10% of its programmed full-scale value by turning off the strong pull-down (open-drain FET) and turning on a weak 25 $\mu\text{A}$  pull-down current. This weak pull-down state is latched until the part enters shutdown or the sensed current rises

to roughly C/6. C/10 indication will not be set if charge current has been reduced due to adapter input current limiting. As the charge current approaches 0A, the PWM continues to operate in full continuous mode. This avoids generation of audible noise, allowing bulk ceramic capacitors to be used in the application.

### Charge Current Monitoring

When the LTC4012-3 is charging, the voltage on the PROG pin varies in direct proportion to the charge current. Referring to Figure 1, the nominal PROG voltage is given by:

$$V_{\text{PROG}} = \frac{I_{\text{CHRG}} \cdot R_{\text{SENSE}} \cdot R_{\text{PROG}}}{R_{\text{IN}}} + 11.67\mu\text{A} \cdot R_{\text{PROG}}$$

Voltage tolerance on PROG is limited by the charge current accuracy specified in the Electrical Characteristics table. Refer to the Applications Information section on programming charge current for additional details.

## OPERATION

### Adapter Input Current Limit

The LTC4012-3 can monitor and limit current from the input DC supply, which is normally an AC adapter. When the programmed adapter input current is reached, charge current is reduced to maintain the desired maximum input current. The ITH and PROG pins will reflect the reduced charge current. This limit function avoids overloading the DC input source, allowing the product to operate at the same time the battery is charging without complex load management algorithms. The battery will automatically be charged at the maximum possible rate that the adapter will support, given the application's operating condition. The LTC4012-3 can only limit input current by reducing charge current, and in this case the charger uses nonsynchronous PWM operation to prevent boosting if the average charge current falls below about 25% of the maximum programmed current. Note that the  $\overline{\text{ICL}}$  indicator output becomes active (low) at an adapter input current level just slightly less than that required for the internal amplifier to begin to assert control over the PWM loop.

### Charger Status Indicator Outputs

The LTC4012-3 open-drain indicator outputs provide valuable information about the IC's operating state and can be used for a variety of purposes in applications. Table 1 summarizes the state of the indicator outputs as a function of LTC4012-3 operation.

**Table 1. LTC4012-3 Open-Drain Indicator Outputs**

CHRG	$\overline{\text{ICL}}$	CHARGER STATE
Off	Off	No DC Input (Shutdown) or Reverse Current
On	Off	Bulk Charge
25 $\mu$ A	Off	Low Current Charge or Initial DCIN – BAT <500mV
On	On	Input Current Limit During Bulk Charge
25 $\mu$ A	On	Input Current Limit During Low Current Charge

### PWM Controller

The LTC4012-3 uses a synchronous step-down architecture to produce high operating efficiency. The nominal operating frequency of 550kHz allows use of small filter components. The following conceptual discussion of basic PWM operation references Figure 1.

The voltage across the external charge current sense resistor  $R_{\text{SENSE}}$  is measured by current amplifier, CA. This instantaneous current ( $V_{\text{SENSE}}/R_{\text{IN}}$ ) is fed to the PROG pin where it is averaged by an external capacitor and converted to a voltage by the programming resistor  $R_{\text{PROG}}$  between PROG and GND. The PROG voltage becomes the average charge current input signal to error amplifier, EA. EA also receives loop control information from the battery voltage feedback input,  $V_{\text{FB}}$ , and the adapter input current limit circuit.

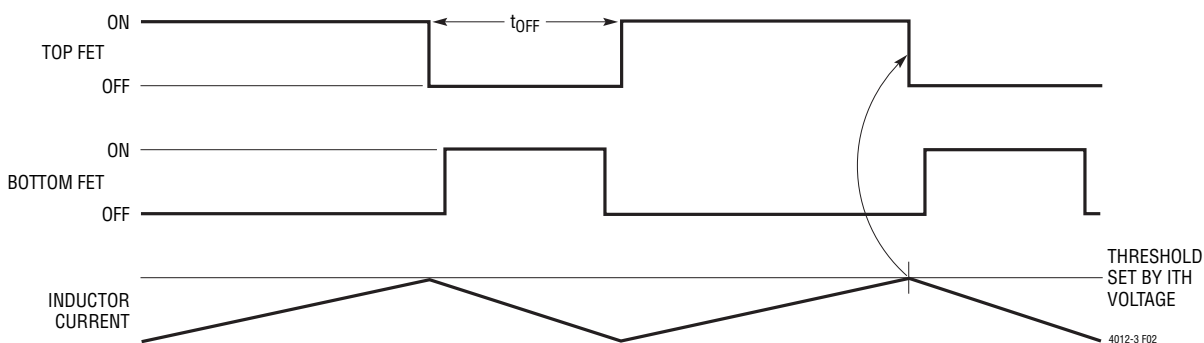

**Figure 2. PWM Waveforms**

## OPERATION

The ITH output of the error amplifier is a scaled control voltage for one input of the PWM comparator, CC. ITH sets a peak inductor current threshold, sensed by R1, to maintain the desired average current through R<sub>SENSE</sub>. The current comparator output does this by switching the state of the RS latch at the appropriate time.

At the beginning of each oscillator cycle, the PWM clock sets the RS latch and turns on the external topside NFET (bottom-side synchronous NFET off) to refresh the current carried by the external inductor L1. The inductor current and voltage across R<sub>SENSE</sub> begin to rise linearly. CA buffers this instantaneous voltage rise and applies it to CC with gain supplied by R1. When the voltage across R1 exceeds the peak level set by the ITH output of EA, the top FET turns off and the bottom FET turns on. The inductor current then ramps down linearly until the next rising PWM clock edge. This closes the loop and sources the correct inductor current to maintain the desired parameter (charge current, battery voltage, or input current). To produce a near constant frequency, the PWM oscillator implements the equation:

$$t_{\text{OFF}} = \frac{\text{CLP} - \text{BAT}}{\text{CLP} \cdot 550\text{kHz}}$$

Repetitive, closed-loop waveforms for stable PWM operation appear in Figure 2.

### PWM Watchdog Timer

As input and output conditions vary, the LTC4012-3 may need to utilize PWM duty cycles approaching 100%. In this case, operating frequency may be reduced well below 550kHz. An internal watchdog timer observes the activity on the TGATE pin. If TGATE is on for more than 40μs, the watchdog activates and forces the bottom NFET on (top NFET off) for about 100ns. This avoids a

potential source of audible noise when using ceramic input or output capacitors and prevents the boost supply capacitor for the top gate driver from discharging. In low drop out operation, the actual charge current may not be able to reach the programmed full-scale value due to the watchdog function.

### Overvoltage Protection

The LTC4012-3 also contains overvoltage detection that prevents transient battery voltage overshoots of more than about 6% above the programmed output voltage. When battery overvoltage is detected, both external MOSFETs are turned off until the overvoltage condition clears, at which time a new soft-start sequence begins. This is useful for properly charging battery packs that use an internal switch to disconnect themselves for performing functions such as calibration or pulse mode charging.

### Reverse Charge Current Protection (Anti-Boost)

Because the LTC4012-3 always attempts to operate synchronously in full continuous mode (to avoid audible noise from ceramic capacitors), reverse average charge current can occur during some invalid operating conditions. INFET PowerPath control avoids boosting a lightly loaded system supply during reverse operation. However, under heavier system loads, CLP may not boost above DCIN, even though reverse average current is flowing. In this case a second circuit monitors indication of reverse average current on PROG.

If either of these circuits detects boost operation, The LTC4012-3 turns off both external MOSFETs until the reverse current condition clears. At that point, a new soft-start sequence begins.

## APPLICATIONS INFORMATION

### Programming Charge Current

The formula for charge current is:

$$I_{\text{CHRG}} = \frac{R_{\text{IN}}}{R_{\text{SENSE}}} \cdot \left( \frac{1.2085\text{V}}{R_{\text{PROG}}} - 11.67\mu\text{A} \right)$$

The LTC4012-3 operates best with 3.01k input resistors, although other resistors near this value can be used to accommodate standard sense resistor values. Refer to the subsequent discussion on inductor selection for other considerations that come into play when selecting input resistors  $R_{\text{IN}}$ .

$R_{\text{SENSE}}$  should be chosen according to the following equation:

$$R_{\text{SENSE}} = \frac{100\text{mV}}{I_{\text{MAX}}}$$

where  $I_{\text{MAX}}$  is the desired maximum charge current  $I_{\text{CHRG}}$ . The 100mV target can be adjusted to some degree to obtain standard  $R_{\text{SENSE}}$  values and/or a desired  $R_{\text{PROG}}$  value, but target voltages lower than 100mV will cause a proportional reduction in current regulation accuracy.

The required minimum resistance between PROG and GND can be determined by applying the suggested expression for  $R_{\text{SENSE}}$  while solving the first equation given above for charge current with  $I_{\text{CHRG}} = I_{\text{MAX}}$ :

$$R_{\text{PROG(MIN)}} = \frac{1.2085\text{V} \cdot R_{\text{IN}}}{0.1\text{V} + 11.67\mu\text{A} \cdot R_{\text{IN}}}$$

If  $R_{\text{IN}}$  is chosen to be 3.01k with a sense voltage of 100mV, this equation indicates a minimum value for  $R_{\text{PROG}}$  of 26.9k. Table 6 gives some examples of recommended charge current programming component values based on these equations.

The resistance between PROG and GND can simply be set with a single a resistor, if only maximum charge current needs to be controlled during the desired charging algorithm.

However, some batteries require a low charge current for initial conditioning when they are heavily discharged. The charge current can then be safely switched to a higher level after conditioning is complete. Figure 3 illustrates one method of doing this with 2-level control of the PROG pin resistance. Turning Q1 off reduces the charge current to  $I_{\text{MAX}}/10$  for battery conditioning. When Q1 is on, the LTC4012-3 is programmed to allow full  $I_{\text{MAX}}$  current for bulk charge. This technique can be expanded through the use of additional digital control inputs for an arbitrary number of pre-programmed current values.

For a truly continuous range of maximum charge current control, pulse width modulation can be used as shown in Figure 4.

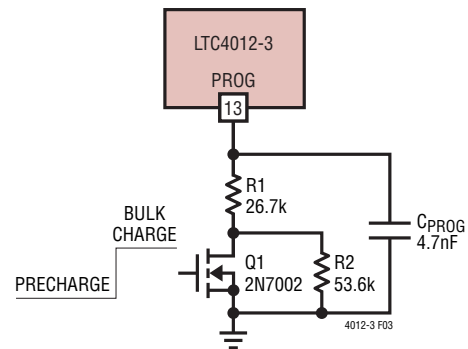

Figure 3. Programming 2-Level Charge Current

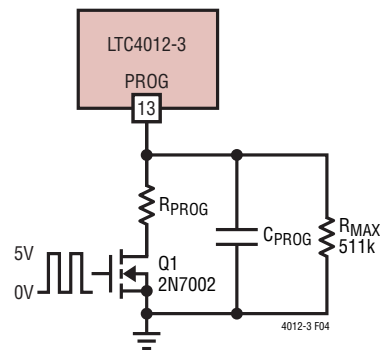

Figure 4. Programming PWM Current

## APPLICATIONS INFORMATION

The value of  $R_{\text{PROG}}$  controls the maximum value of charge current which can be programmed (Q1 continuously on). PWM of the Q1 gate voltage changes the value of  $R_{\text{PROG}}$  to produce lower currents. The frequency of this modulation should be higher than a few kHz, and  $C_{\text{PROG}}$  must be increased to reduce the ripple caused by switching Q1. In addition, it may be necessary to increase loop compensation capacitance connected to ITH to maintain stability or prevent large current overshoot during start-up. Selecting a higher Q1 PWM frequency ( $\approx 10\text{kHz}$ ) will reduce the need to change  $C_{\text{PROG}}$  or other compensation values. Charge current will be proportional to the duty cycle of the PWM input on the gate of Q1.

### Programming LTC4012-3 Output Voltage

Figure 5 shows the external circuit for programming the charger output voltage. The voltage is then governed by the following equation:

$$V_{\text{BAT}} = \frac{1.2085\text{V} \cdot (R1 + R2)}{R2}, R2 = R2A + R2B$$

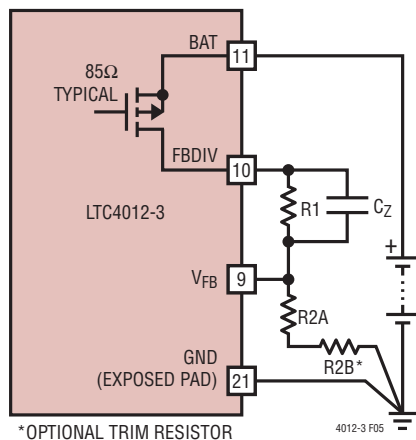

Figure 5. Programming Output Voltage

See Table 2 for approximate resistor values for R2.

$$R1 = R2 \left( \frac{V_{\text{BAT}}}{1.2085\text{V}} - 1 \right), R2 = R2A + R2B$$

Selecting R2 to be less than 50k and the sum of R1 and R2 at least 200k or above, achieves the lowest possible error at the  $V_{\text{FB}}$  sense input. Note that sources of error such as R1 and R2 tolerance, FBDIV  $R_{\text{ON}}$  or  $V_{\text{FB}}$  input impedance are not included in the specifications given in the Electrical Characteristics. This leads to the possibility that very accurate (0.1%) external resistors might be required. Actually, the temperature rise of the LTC4012-3 will rarely exceed  $50^{\circ}\text{C}$  at the end of charge, because charge current will have tapered to a low level. This means that 0.25% resistors will normally provide the required level of overall accuracy. Table 2 gives recommended values for R1 and R2 for popular lithium-ion battery voltages. For values of R1 above 200k, addition of capacitor  $C_Z$  may improve transient response and loop stability. A value of 10pF is normally adequate.

Table 2. Programming Output Voltage

$V_{\text{BAT}}$ (V)	R1 (0.25%) (k $\Omega$ )	R2A (0.25%) (k $\Omega$ )	R2B (1%)* ( $\Omega$ )
4.1	165	69	–
4.2	167	67.3	200
8.2	162	28	–
8.4	169	28.4	–
12.3	301	32.8	–
12.6	294	31.2	–
16.4	284	22.6	–
16.8	271	21	–
20.5	316	19.8	–
21	298	18.2	–
24.6	298	15.4	–
25.2	397	20	–

\*To Obtain Desired Accuracy Requires Series Resistors For R2.

## APPLICATIONS INFORMATION

### Programming Input Current Limit

To set the input current limit,  $I_{LIM}$ , the minimum wall adapter current rating must be known. To account for the tolerance of the LTC4012-3 input current sense circuit, 5% should be subtracted from the adapter's minimum rated output. Refer to Figure 6 and program the input current limit function with the following equation:

$$R_{CL} = \frac{100\text{mV}}{I_{LIM}}$$

where  $I_{LIM}$  is the desired maximum current draw from the DC (adapter) input, including adjustments for tolerance, if any.

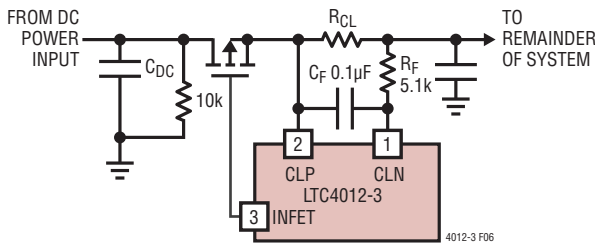

Figure 6. Programming Input Current Limit

Often an AC adapter will include a rated current output margin of at least +10%. This can allow the adapter current limit value to simply be programmed to the actual minimum rated adapter output current. Table 3 shows some common  $R_{CL}$  current limit programming values.

A lowpass filter formed by  $R_F$  (5.1k) and  $C_F$  (0.1µF) is required to eliminate switching noise from the LTC4012-3 PWM and other system components. If input current limiting is not desired, CLN should be shorted to CLP while CLP remains connected to power.

Table 3. Common  $R_{CL}$  Values

ADAPTER RATING (A)	$R_{CL}$ VALUE (1%) (Ω)	$R_{CL}$ POWER DISSIPATION (W)	$R_{CL}$ POWER RATING (W)
1.00	0.100	0.100	0.25
1.25	0.080	0.125	0.25
1.50	0.068	0.150	0.25
1.75	0.056	0.175	0.25
2.00	0.050	0.200	0.25
2.50	0.039	0.244	0.50
3.00	0.033	0.297	0.50
3.50	0.027	0.331	0.50
4.00	0.025	0.400	0.50

Figure 7 shows an optional circuit that can influence the parameters of the input current limit in two ways. The first option is to lower the power dissipation of  $R_{CL}$  at the expense of accuracy without changing the input current limit value. The second is to make the input current limit value programmable.

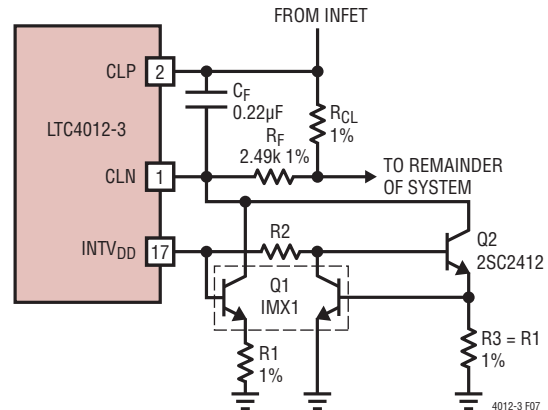

Figure 7. Adjusting Input Current Limit

## APPLICATIONS INFORMATION

The overall accuracy of this circuit needs to be better than the power source current tolerance or be margined such that the worse-case error remains under the power source limits.

The accuracy of the Figure 7 circuit is a function of the  $INTV_{DD}$ ,  $V_{BE}$ ,  $R_{CL}$ ,  $R_F$ ,  $R_1$  and  $R_3$  tolerances. To improve accuracy, the tolerance of  $R_F$  should be changed from 5.1k, 5% to a 2.49k 1% resistor.  $R_{CL}$  and the programming resistors  $R_1$  and  $R_3$  should also be 1% tolerance such that the dominant error is  $INTV_{DD}$  ( $\pm 3\%$ ). Bias resistor  $R_2$  can be 5%. When choosing NPN transistors, both need to have good gain ( $>100$ ) at  $10\mu A$  levels. Low gain NPNs will increase programming errors. Q1 must be a matched NPN pair. Since  $R_F$  has been reduced in value by half, the capacitor value of  $C_F$  should double to  $0.22\mu F$  to remain effective at filtering out any noise.

If you wish to reduce  $R_{CL}$  power dissipation for a given current limit, the programming equation becomes:

$$R_{CL} = \frac{100mV - \left( \frac{5 \cdot 2.49k}{R_1} \right)}{I_{LIM}}$$

If you wish to make the input current limit programmable, the equation becomes:

$$I_{LIM} = \frac{100mV - \left( \frac{5 \cdot 2.49k}{R_1} \right)}{R_{CL}}$$

The equation governing  $R_2$  for both applications is based on the value of  $R_1$ .  $R_3$  should always be equal to  $R_1$ .

$$R_2 = 0.875 \cdot R_1$$

In many notebook applications, there are situations where two different  $I_{LIM}$  values are needed to allow two different power adapters or power sources to be used. In such cases, start by setting  $R_{LIM}$  for the high power  $I_{LIM}$  configuration and then use Figure 7 to set the lower  $I_{LIM}$  value. To toggle between the two  $I_{LIM}$  values, take the three ground connections shown in Figure 7, combine them into one common connection and use a small-signal NFET (2N7002) to open or close that common connection to circuit ground. When the NFET is off, the circuit is defeated (floating) allowing  $I_{LIM}$  to be the maximum value. When the NFET is on, the circuit will become active and  $I_{LIM}$  will drop to the lower set value.

### Monitoring Charge Current

The PROG pin voltage can be used to indicate charge current where 1.2085V indicates full programmed current (1C) and zero charge current is approximately equal to  $R_{PROG} \cdot 11.67\mu A$ . PROG voltage varies in direct proportion to the charge current between this zero-current (offset) value and 1.2085V. When monitoring the PROG pin voltage, using a buffer amplifier as shown in Figure 8 will minimize charge current errors. The buffer amplifier may be powered from the  $INTV_{DD}$  pin or any supply that is always on when the charger is on.

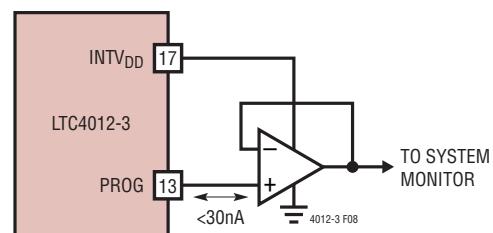

Figure 8. PROG Voltage Buffer

## APPLICATIONS INFORMATION

### C/10 $\overline{\text{CHRG}}$ Indicator

The value chosen for  $R_{\text{PROG}}$  has a strong influence on charge current monitoring and the accuracy of the C/10 charge indicator output ( $\overline{\text{CHRG}}$ ). The LTC4012-3 uses the voltage on the PROG pin to determine when charge current has dropped to the C/10 threshold. The nominal threshold of 400mV produces an accurate low charge current indication of C/10 as long as  $R_{\text{PROG}} = 26.7\text{k}$ , independent of all other current programming considerations. However, it may sometimes be necessary to deviate from this value to satisfy other application design goals.

If  $R_{\text{PROG}}$  is greater than 26.7k, the actual level at which low charge current is detected will be less than C/10. The highest value of  $R_{\text{PROG}}$  that can be used while reliably indicating low charge current before reaching final  $V_{\text{BAT}}$  is 30.1k.  $R_{\text{PROG}}$  can safely be set to values higher than this, but low current indication will be lost.

If  $R_{\text{PROG}}$  is less than 26.7k, low charge current detection occurs at a level higher than C/10. More importantly, the LTC4012-3 becomes increasingly sensitive to reverse current. The lowest value of  $R_{\text{PROG}}$  that can be used without the risk of erroneous boost operation detection at end of charge is 26.1k. Values of  $R_{\text{PROG}}$  less than this should not be used. See the Operation section for more information about reverse current.

The nominal fractional value of  $I_{\text{MAX}}$  at which C/10 indication occurs is given by:

$$\frac{I_{\text{C10}}}{I_{\text{MAX}}} = \frac{400\text{mV} - (R_{\text{PROG}} \cdot 11.67\mu\text{A})}{1.2085\text{V} - (R_{\text{PROG}} \cdot 11.67\mu\text{A})}$$

Direct digital monitoring of C/10 indication is possible with an external application circuit like the one shown in Figure 9.

By using two different value pull-up resistors, a microprocessor can detect three states from this pin (charging, C/10 and not charging). See Figure 10. When a digital output port (OUT) from the microprocessor drives one of the resistors and a second digital input port polls the network, the charge state can be determined as shown in Table 4.

Table 4. Digital Read Back State (IN, Figure 10)

LTC4012-3 CHARGER STATE	OUT STATE	
	Hi-Z	1
Off	1	1
C/10 Charge	0	1
Bulk Charge	0	0

### Input and Output Capacitors

In addition to typical input supply bypassing (0.1 $\mu\text{F}$ ) on DCIN, the relatively high ESR of aluminum electrolytic capacitors is helpful for reducing ringing when hot-plugging the charger to the AC adapter. Refer to LTC Application Note 88 for more information.

The input capacitor between system power (drain of top FET, Figure 1) and GND is required to absorb all input PWM ripple current, therefore it must have adequate ripple current rating. Maximum RMS ripple current is typically one-half of the average battery charge current. Actual capacitance value is not critical, but using the highest possible voltage rating on PWM input capacitors will minimize problems. Consult with the manufacturer before use.

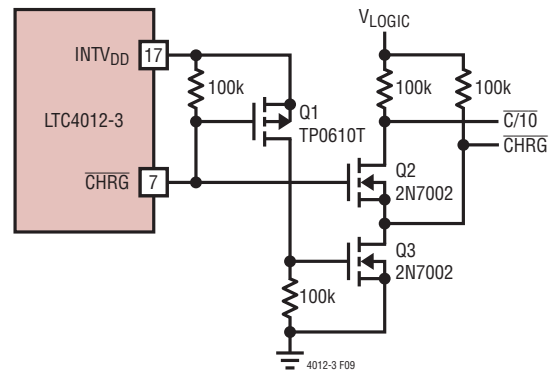

Figure 9. Digital C/10 Indicator

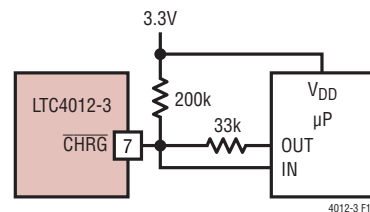

Figure 10. Microprocessor Status Interface

## APPLICATIONS INFORMATION

The output capacitor shown across the battery and ground must also absorb PWM output ripple current. The general formula for this capacitor current is:

$$I_{\text{RMS}} = \frac{0.29 \cdot V_{\text{BAT}} \cdot \left(1 - \frac{V_{\text{BAT}}}{V_{\text{CLP}}}\right)}{L1 \cdot f_{\text{PWM}}}$$

For example,  $I_{\text{RMS}} = 0.22\text{A}$  with:

$$V_{\text{BAT}} = 12.6\text{V}$$

$$V_{\text{CLP}} = 19\text{V}$$

$$L1 = 10\mu\text{H}$$

$$f_{\text{PWM}} = 550\text{kHz}$$

High capacity ceramic capacitors (20 $\mu\text{F}$  or more) available from a variety of manufacturers can be used for input/output capacitors. Other alternatives include OS-CON and POSCAP capacitors from Sanyo.

Low ESR solid tantalum capacitors have high ripple current rating in a relatively small surface mount package, but exercise caution when using tantalum for input or output bulk capacitors. High input surge current can be created when the adapter is hot-plugged to the charger or when a battery is connected to the charger. Solid tantalum capacitors have a known failure mechanism when subjected to very high surge currents. Select tantalum capacitors that have high surge current ratings or have been surge tested.

EMI considerations usually make it desirable to minimize ripple current in battery leads. Adding Ferrite beads or inductors can increase battery impedance at the nominal 550kHz switching frequency. Switching ripple current splits between the battery and the output capacitor in inverse relation to capacitor ESR and the battery impedance. If the ESR of the output capacitor is 0.2 $\Omega$  and the battery impedance is raised to 4 $\Omega$  with a ferrite bead, only 5% of the current ripple will flow to the battery.

### Inductor Selection

Higher switching frequency generally results in lower efficiency because of MOSFET gate charge losses, but it allows smaller inductor and capacitor values to be used. A primary effect of the inductor value L1 is the amplitude of ripple current created. The inductor ripple current  $\Delta I_L$  decreases with higher inductance and PWM operating frequency:

$$\Delta I_L = \frac{V_{\text{BAT}} \cdot \left(1 - \frac{V_{\text{BAT}}}{V_{\text{CLP}}}\right)}{L1 \cdot f_{\text{PWM}}}$$

Accepting larger values of  $\Delta I_L$  allows the use of low inductance, but results in higher output voltage ripple and greater core losses. Lower charge currents generally call for larger inductor values.

The LTC4012-3 limits maximum instantaneous peak inductor current during every PWM cycle. To avoid unstable switch waveforms, the ripple current must satisfy:

$$\Delta I_L < 2 \cdot \left( \frac{150\text{mV}}{R_{\text{SENSE}}} - I_{\text{MAX}} \right)$$

so choose:

$$L1 > \frac{0.125 \cdot V_{\text{CLP}}}{f_{\text{PWM}} \cdot \left( \frac{150\text{mV}}{R_{\text{SENSE}}} - I_{\text{MAX}} \right)}$$

For C-grade parts, a reasonable starting point for setting ripple current is  $\Delta I_L = 0.4 \cdot I_{\text{MAX}}$ . For I-grade parts, use  $\Delta I_L = 0.2 \cdot I_{\text{MAX}}$  **only** if the IC will actually be used to charge batteries over the wider I-grade temperature range. The voltage compliance of internal LTC4012-3 circuits also imposes limits on ripple current. Select  $R_{\text{IN}}$  (in Figure 1) to avoid average current errors in high ripple designs. The following equation can be used for guidance:

$$\frac{R_{\text{SENSE}} \cdot \Delta I_L}{50\mu\text{A}} \leq R_{\text{IN}} \leq \frac{R_{\text{SENSE}} \cdot \Delta I_L}{20\mu\text{A}}$$

## APPLICATIONS INFORMATION

$R_{IN}$  should not be less than 2.37k or more than 6.04k. Values of  $R_{IN}$  greater than 3.01k may cause some reduction in programmed current accuracy. Use these equations and guidelines, as represented in Table 5, to help select the correct inductor value. This table was developed for C-grade parts to maintain maximum  $\Delta I_L$  near  $0.6 \cdot I_{MAX}$  with  $f_{PWM}$  at 550kHz and  $V_{BAT} = 0.5 \cdot V_{CLP}$  (the point of maximum  $\Delta I_L$ ), assuming that inductor value could also vary by 25% at  $I_{MAX}$ . For I-grade parts, reduce maximum  $\Delta I_L$  to less than  $0.4 \cdot I_{MAX}$ , but **only** if the IC will actually be used to charge batteries over the wider I-grade temperature range. In that case, a good starting point can be found by multiplying the inductor values shown in Table 5 by a factor of 1.6 and rounding up to the nearest standard value.

**Table 5. Minimum Typical Inductor Values**

$V_{CLP}$	L1 (Typ)	$I_{MAX}$	$R_{SENSE}$	$R_{IN}$	$R_{PROG}$
<10V	$\geq 10\mu H$	1A	100m $\Omega$	3.01k	26.7k
10V to 20V	$\geq 20\mu H$	1A	100m $\Omega$	3.01k	26.7k
>20V	$\geq 28\mu H$	1A	100m $\Omega$	3.01k	26.7k
<10V	$\geq 5.1\mu H$	2A	50m $\Omega$	3.01k	26.7k
10V to 20V	$\geq 10\mu H$	2A	50m $\Omega$	3.01k	26.7k
>20V	$\geq 14\mu H$	2A	50m $\Omega$	3.01k	26.7k
<10V	$\geq 3.4\mu H$	3A	33m $\Omega$	3.01k	26.7k
10V to 20V	$\geq 6.8\mu H$	3A	33m $\Omega$	3.01k	26.7k
>20V	$\geq 9.5\mu H$	3A	33m $\Omega$	3.01k	26.7k
<10V	$\geq 2.5\mu H$	4A	25m $\Omega$	3.01k	26.7k
10V to 20V	$\geq 5.1\mu H$	4A	25m $\Omega$	3.01k	26.7k
>20V	$\geq 7.1\mu H$	4A	25m $\Omega$	3.01k	26.7k

To guarantee that a chosen inductor is optimized in any given application, use the design equations provided and perform bench evaluation in the target application, particularly at duty cycles below 20% or above 80% where PWM frequency can be much less than the nominal value of 550kHz.

### TGATE BOOST Supply

Use the external components shown in Figure 11 to develop a bootstrapped BOOST supply for the TGATE FET driver. A good set of equations governing selection of the two capacitors is:

$$C1 = \frac{20 \cdot Q_G}{4.5V}, C2 = 20 \cdot C1$$

where  $Q_G$  is the rated gate charge of the top external NFET with  $V_{GS} = 4.5V$ . The maximum average diode current is then given by:

$$I_D = Q_G \cdot 665kHz$$

To improve efficiency by increasing  $V_{GS}$  applied to the top FET, substitute a Schottky diode with low reverse leakage for D1.

PWM jitter has been observed in some designs operating at higher  $V_{IN}/V_{OUT}$  ratios. This jitter does not substantially affect DC charge current accuracy. A series resistor with a value of 5 $\Omega$  to 20 $\Omega$  can be inserted between the cathode of D1 and the BOOST pin to remove this jitter, if present. A resistor case size of 0603 or larger is recommended to lower ESL and achieve the best results.

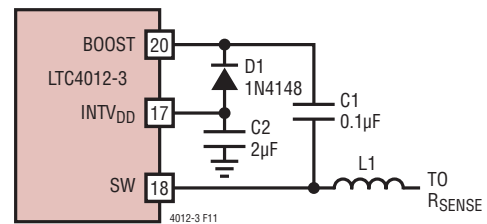

**Figure 11. TGATE Boost Supply**

## APPLICATIONS INFORMATION

### FET Selection

Two external power MOSFETs must be selected for use with the charger: an N-channel power switch (top FET) and an N-channel synchronous rectifier (bottom FET). Peak gate-to-source drive levels are internally set to about 5V. Consequently, logic-level FETs must be used. In addition to the fundamental DC current, selection criteria for these MOSFETs also include channel resistance  $R_{DS(ON)}$ , total gate charge  $Q_G$ , reverse transfer capacitance  $C_{RSS}$ , maximum rated drain-source voltage  $BV_{DSS}$  and switching characteristics such as  $t_{d(ON/OFF)}$ . Power dissipation for each external FET is given by:

$$P_{D(TOP)} = \frac{V_{BAT} \cdot I_{MAX}^2 \cdot (1 + \delta\Delta T) R_{DS(ON)}}{V_{CLP}} + k \cdot V_{CLP}^2 \cdot I_{MAX} \cdot C_{RSS} \cdot 665\text{kHz}$$

$$P_{D(BOT)} = \frac{(V_{CLP} - V_{BAT}) \cdot I_{MAX}^2 \cdot (1 + \delta\Delta T) R_{DS(ON)}}{V_{CLP}}$$

where  $\delta$  is the temperature dependency of  $R_{DS(ON)}$ ,  $\Delta T$  is the temperature rise above the point specified in the FET data sheet for  $R_{DS(ON)}$  and  $k$  is a constant inversely related to the internal LTC4012-3 top gate driver. The term  $(1 + \delta\Delta T)$  is generally given for a MOSFET in the form of a normalized  $R_{DS(ON)}$  curve versus temperature, but  $\delta$  of  $0.005/^\circ\text{C}$  can be used as a suitable approximation for logic-level FETs if other data is not available.  $C_{RSS} = \Delta Q_{GD}/\Delta V_{DS}$  is usually specified in the MOSFET characteristics. The constant  $k = 2$  can be used in estimating top FET dissipation. The LTC4012-3 is designed to work best with external FET switches with a total gate charge at 5V of 15nC or less.

For  $V_{CLP} < 20\text{V}$ , high charge current efficiency generally improves with larger FETs, while for  $V_{CLP} > 20\text{V}$ , top gate transition losses increase rapidly to the point that using a topline NFET with higher  $R_{DS(ON)}$  but lower  $C_{RSS}$  can actually provide higher efficiency. If the charger will be operated with a duty cycle above 85%, overall efficiency is normally improved by using a larger top FET.

The synchronous (bottom) FET losses are greatest at high input voltage or during a short circuit, which forces a low side duty cycle of nearly 100%. Increasing the size of this FET lowers its losses but increases power dissipation in the LTC4012-3. Using asymmetrical FETs will normally achieve cost savings while allowing optimum efficiency.

Select FETs with  $BV_{DSS}$  that exceeds the maximum  $V_{CLP}$  voltage that will occur. Both FETs are subjected to this level of stress during operation. Many logic-level MOSFETs are limited to 30V or less.

The LTC4012-3 uses an improved adaptive TGATE and BGATE drive that is insensitive to MOSFET inertial delays,  $t_{d(ON/OFF)}$ , to avoid overlap conduction losses. Switching characteristics from power MOSFET data sheets apply only to a specific test fixture, so there is no substitute for bench evaluation of external FETs in the target application. In general, MOSFETs with lower inertial delays will yield higher efficiency.

### Diode Selection

A Schottky diode in parallel with the bottom FET and/or top FET in an LTC4012-3 application clamps SW during the non-overlap times between conduction of the top and bottom FET switches. This prevents the body diode of the MOSFETs from forward biasing and storing charge, which could reduce efficiency as much as 1%. One or both diodes can be omitted if the efficiency loss can be tolerated. A 1A Schottky is generally a good size for 3A chargers due to the low duty cycle of the non-overlap times. Larger diodes can actually result in additional efficiency (transition) losses due to larger junction capacitance.

### Loop Compensation and Soft-Start

The three separate PWM control loops of the LTC4012-3 can be compensated by a single set of components attached between the ITH pin and GND. As shown in the typical LTC4012-3 application, a 6.04k resistor in series with a capacitor of at least  $0.1\mu\text{F}$  provides adequate loop compensation for the majority of applications.

## APPLICATIONS INFORMATION

The LTC4012-3 can be soft-started with the compensation capacitor on the ITH pin. At start-up, ITH will quickly rise to about 0.25V, then ramp up at a rate set by the compensation capacitor and the 40 $\mu$ A ITH bias current. The full programmed charge current will be reached when ITH reaches approximately 2V. With a 0.1 $\mu$ F capacitor, the time to reach full charge current is usually greater than 1.5ms. This capacitor can be increased if longer start-up times are required, but loop bandwidth and dynamic response will be reduced.

### INTV<sub>DD</sub> Regulator Output

Bypass the INTV<sub>DD</sub> regulator output to GND with a low ESR X5R or X7R ceramic capacitor with a value of 0.47 $\mu$ F or larger. The capacitor used to build the BOOST supply (C2 in Figure 11) can serve as this bypass. Do not draw more than 30mA from this regulator for the host system, governed by IC power dissipation.

### Calculating IC Power Dissipation

The user should ensure that the maximum rated junction temperature is not exceeded under all operating conditions. The thermal resistance of the LTC4012-3 package ( $\theta_{JA}$ ) is 37°C/W, provided the Exposed Pad is in good thermal contact with the PCB. The actual thermal resistance in the application will depend on forced air cooling and other heat sinking means, especially the amount of copper on the PCB to which the LTC4012-3 is attached. The following formula may be used to estimate the maximum average power dissipation,  $P_D$  (in watts), of the LTC4012-3, which is dependent upon the gate charge of the external MOSFETs. This gate charge, which is a function of both gate and drain voltage swings, is determined from specifications or graphs in the manufacturer's data sheet. For the equation below, find the gate charge for each transistor assuming 5V gate swing and a drain voltage swing equal to the maximum  $V_{CLP}$  voltage. Maximum LTC4012-3 power dissipation under normal operating conditions is then given by:

$$P_D = DCIN(3mA + I_{DD} + 665kHz(Q_{TGATE} + Q_{BGATE})) - 5I_{DD}$$

where:

$I_{DD}$  = Average external INTV<sub>DD</sub> load current, if any

$Q_{TGATE}$  = Gate charge of external top FET in Coulombs

$Q_{BGATE}$  = Gate charge of external bottom FET in Coulombs

### PCB Layout Considerations

To prevent magnetic and electrical field radiation and high frequency resonant problems, proper layout of the components connected to the LTC4012-3 is essential. Refer to Figure 12. For maximum efficiency, the switch node rise and fall times should be minimized. The following PCB design priority list will help insure proper topology. Layout the PCB using this specific order.

1. Input capacitors should be placed as close as possible to switching FET supply and ground connections with the shortest copper traces possible. The switching FETs must be on the same layer of copper as the input capacitors. Vias should not be used to make these connections.
2. Place the LTC4012-3 close to the switching FET gate terminals, keeping the connecting traces short to produce clean drive signals. This rule also applies to IC supply and ground pins that connect to the switching FET source pins. The IC can be placed on the opposite side of the PCB from the switching FETs.

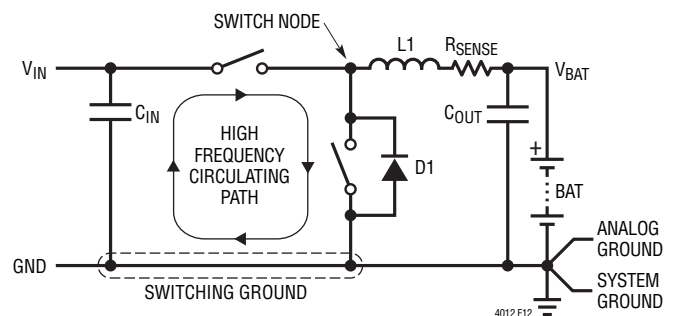

Figure 12. High Speed Switching Path

## APPLICATIONS INFORMATION

- Place the inductor input as close as possible to the switching FETs. Minimize the surface area of the switch node. Make the trace width the minimum needed to support the programmed charge current. Use no copper fills or pours. Avoid running the connection on multiple copper layers in parallel. Minimize capacitance from the switch node to any other trace or plane.
- Place the charge current sense resistor immediately adjacent to the inductor output, and orient it such that current sense traces to the LTC4012-3 are not long. These feedback traces need to be run together as a single pair with the smallest spacing possible on any given layer on which they are routed. Locate any filter component on these traces next to the LTC4012-3, and not at the sense resistor location.
- Place output capacitors adjacent to the sense resistor output and ground.
- Output capacitor ground connections must feed into the same copper that connects to the input capacitor ground before connecting back to system ground.
- Connection of switching ground to system ground, or any internal ground plane, should be single-point. If the system has an internal system ground plane, a good way to do this is to cluster vias into a single star point to make the connection.
- Route analog ground as a trace tied back to the LTC4012-3 GND pin and paddle before connecting to any other ground. Avoid using the system ground plane. A useful CAD technique is to make analog ground a separate ground net and use a  $0\Omega$  resistor to connect analog ground to system ground.
- A good rule of thumb for via count in a given high current path is to use 0.5A per via. Be consistent when applying this rule.
- If possible, place all the parts listed above on the same PCB layer.
- Copper fills or pours are good for all power connections except as noted above in Rule 3. Copper planes on multiple layers can also be used in parallel. This helps with thermal management and lowers trace inductance, which further improves EMI performance.
- For best current programming accuracy, provide a Kelvin connection from  $R_{SENSE}$  to CSP and CSN. See Figure 13 for an example.
- It is important to minimize parasitic capacitance on the CSP and CSN pins. The traces connecting these pins to their respective resistors should be as short as possible.

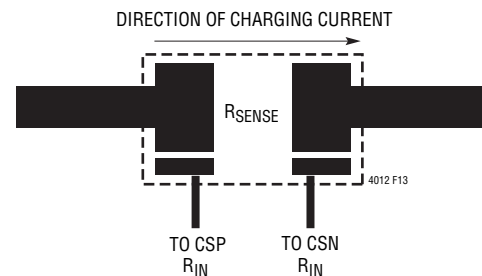
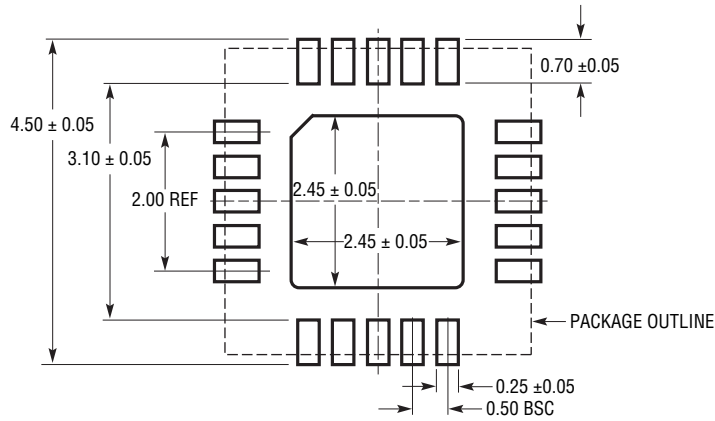

Figure 13. Kelvin Sensing of Charge Current

**PACKAGE DESCRIPTION**

**UF Package**  
**20-Lead Plastic QFN (4mm × 4mm)**  
 (Reference LTC DWG # 05-08-1710 Rev A)



RECOMMENDED SOLDER PAD PITCH AND DIMENSIONS  
 APPLY SOLDER MASK TO AREAS THAT ARE NOT SOLDERED

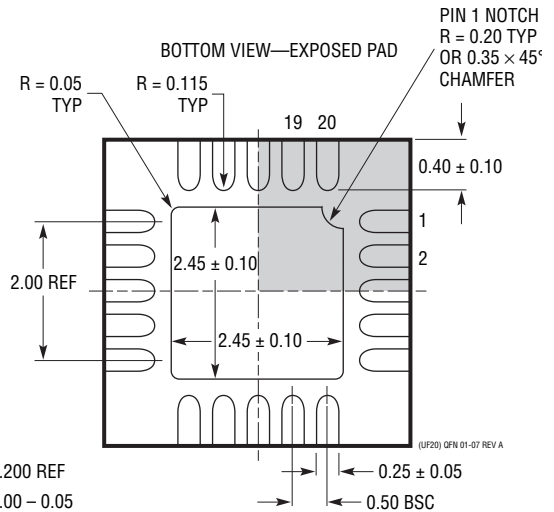
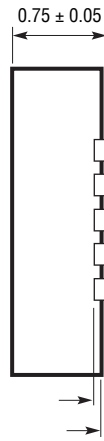
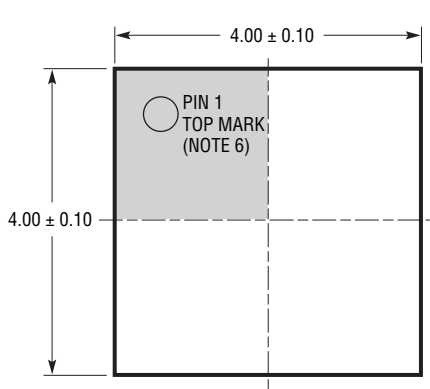

- NOTE:
1. DRAWING IS PROPOSED TO BE MADE A JEDEC PACKAGE OUTLINE MO-220 VARIATION (WGGD-1)—TO BE APPROVED
  2. DRAWING NOT TO SCALE
  3. ALL DIMENSIONS ARE IN MILLIMETERS
  4. DIMENSIONS OF EXPOSED PAD ON BOTTOM OF PACKAGE DO NOT INCLUDE MOLD FLASH. MOLD FLASH, IF PRESENT, SHALL NOT EXCEED 0.15mm ON ANY SIDE
  5. EXPOSED PAD SHALL BE SOLDER PLATED
  6. SHADED AREA IS ONLY A REFERENCE FOR PIN 1 LOCATION ON THE TOP AND BOTTOM OF PACKAGE

**REVISION HISTORY** (Revision history begins at Rev B)

REV	DATE	DESCRIPTION	PAGE NUMBER
B	3/10	I-Grade Part Added. Reflected Throughout the Data Sheet	1 to 28



## Looking for pricing, stock, or lifecycle information?

Click below to explore more details on WIN SOURCE:

- ⊖ [View LTC4012CUF-3#TRPBF on WIN SOURCE](#)
- ⊖ [Linear Technology Information](#)

## Optimize Your Supply Chain with WIN SOURCE Solutions

- ✓ Global Sourcing Solution
- ✓ Obsolete Management
- ✓ Cost Control Management
- ✓ Shortage Management
- ✓ Alternative Solution
- ✓ Excess Inventory Management