



**THE DATASHEET OF  
LTC3559EUD#PBF**



# Linear USB Battery Charger with Dual Buck Regulators

## FEATURES

### Battery Charger

- Standalone USB Charger
- Up to 950mA Charge Current Programmable via Single Resistor
- HPWR Input Selects 20% or 100% of Programmed Charge Current
- NTC Input for Temperature Qualified Charging
- Internal Timer Termination
- Bad Battery Detection
- CHRG Indicates C/10 or Timeout

### Buck Regulators

- 400mA Output Current
- 2.25MHz Constant Frequency Operation
- Zero Current in Shutdown
- Low Noise Pulse Skip Operation or Power Saving Burst Mode Operation
- Low No-Load Quiescent Current: 35µA
- Available in a Low Profile Thermally Enhanced 16-Lead 3mm × 3mm QFN Package

## APPLICATIONS

- SD/Flash-Based MP3 Players
- Low Power Handheld Applications

## DESCRIPTION

The LTC<sup>®</sup>3559/LTC3559-1 are USB battery chargers with dual high efficiency buck regulators. The parts are ideally suited to power single-cell Li-Ion/Polymer based handheld applications needing multiple supply rails.

Battery charge current is programmed via the PROG pin and the HPWR pin, with capability up to 950mA at the BAT pin. The battery charger has an NTC input for temperature qualified charging. The CHRG pin allows battery status to be monitored continuously during the charging process. An internal timer controls charger termination.

Each monolithic synchronous buck regulator provides up to 400mA of output current while operating at efficiencies greater than 90% over the entire Li-Ion/Polymer range. A MODE pin provides the flexibility to place both buck regulators in a power saving Burst Mode<sup>®</sup> operation or a low noise pulse skip mode.

The LTC3559/LTC3559-1 are offered in a low profile thermally enhanced 16-lead (3mm × 3mm) QFN package.

LT, LT, LTC and LTM are registered trademarks of Linear Technology Corporation. All other trademarks are the property of their respective owners.

## TYPICAL APPLICATION

USB Charger Plus Dual Buck Regulators

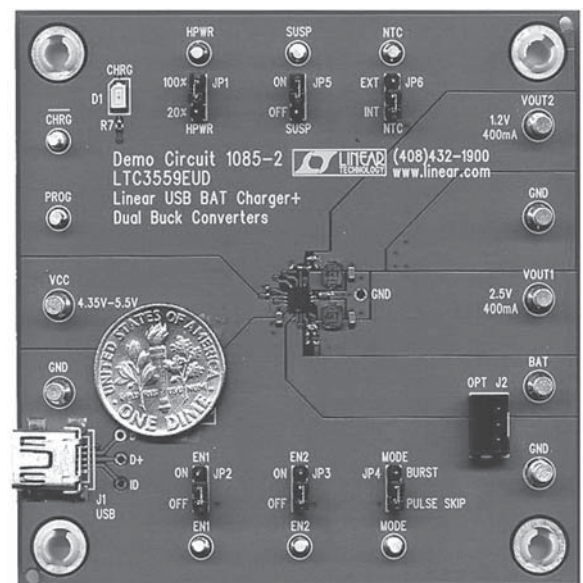
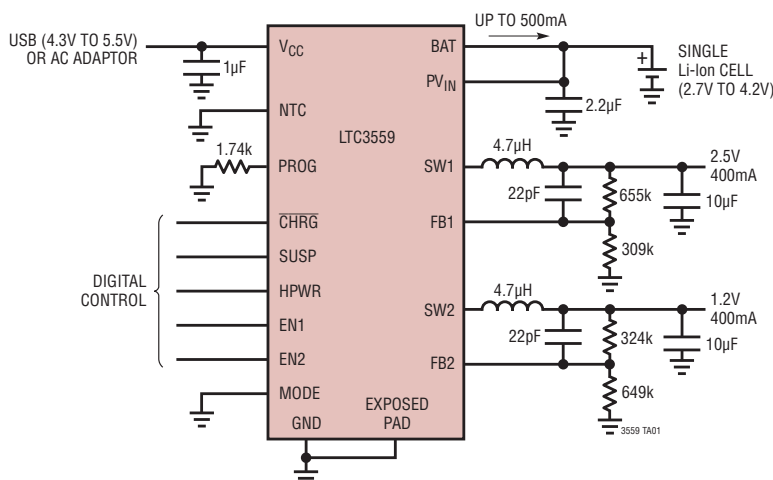

3559fb

# LTC3559/LTC3559-1

## ABSOLUTE MAXIMUM RATINGS

(Note 1)

$V_{CC}$ (Transient); $t < 1\text{ms}$ and Duty Cycle $< 1\%$ .....	-0.3V to 7V
$V_{CC}$ (Static) .....	-0.3V to 6V
BAT, CHRG, SUSP .....	-0.3V to 6V
HPWR, NTC, PROG .....	-0.3V to Max ( $V_{CC}$ , BAT) + 0.3V
PROG Pin Current .....	1.25mA
BAT Pin Current .....	1A
$PV_{IN}$ .....	-0.3V to BAT + 0.3V
EN1, EN2, MODE.....	-0.3V to 6V
FB1, FB2, SW1, SW2 .....	-0.3V to $PV_{IN}$ + 0.3V or 6V
$I_{SW1}$ , $I_{SW2}$ .....	600mA DC
Junction Temperature (Note 2) .....	125°C
Operating Temperature Range (Note 3)....	-40°C to 85°C
Storage Temperature.....	-65°C to 125°C

## PIN CONFIGURATION

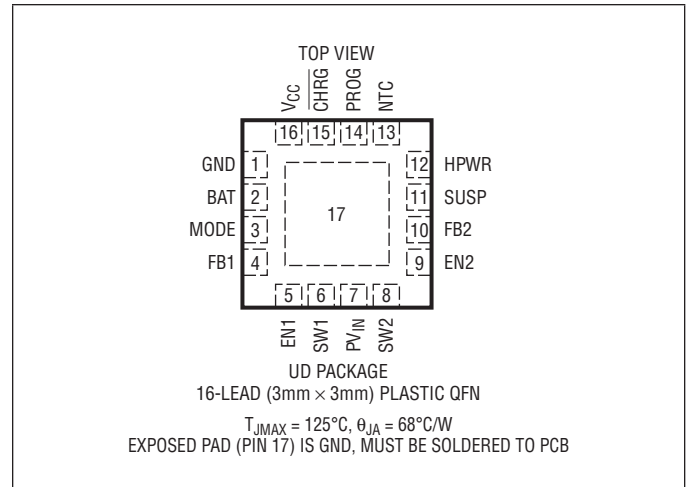

## ORDER INFORMATION

LEAD FREE FINISH	TAPE AND REEL	PART MARKING	PACKAGE DESCRIPTION	TEMPERATURE RANGE
LTC3559EUD#PBF	LTC3559EUD#TRPBF	LCMB	16-Lead (3mm x 3mm) Plastic QFN	-40°C to 85°C
LTC3559EUD-1#PBF	LTC3559EUD-1#TRPBF	LDQD	16-Lead (3mm x 3mm) Plastic QFN	-40°C to 85°C

Consult LTC Marketing for parts specified with wider operating temperature ranges.

Consult LTC Marketing for information on non-standard lead based finish parts.

For more information on lead free part marking, go to: <http://www.linear.com/leadfree/>

For more information on tape and reel specifications, go to: <http://www.linear.com/tapeandreeel/>

## ELECTRICAL CHARACTERISTICS

The ● denotes specifications that apply over the full operating temperature range, otherwise specifications are at  $T_A = 25^\circ\text{C}$ .

SYMBOL	PARAMETER	CONDITIONS	MIN	TYP	MAX	UNITS
<b>Battery Charger. <math>V_{CC} = 5\text{V}</math>, <math>BAT = PV_{IN} = 3.6\text{V}</math>, <math>R_{PROG} = 1.74\text{k}</math>, <math>HPWR = 5\text{V}</math>, <math>SUSP = NTC = EN1 = EN2 = 0\text{V}</math></b>						
$V_{CC}$	Input Supply Voltage		● 4.3		5.5	V
$I_{VCC}$	Battery Charger Quiescent Current (Note 4)	Standby Mode, Charge Terminated Suspend Mode, $V_{SUSP} = 5\text{V}$		200 8.5	400 17	$\mu\text{A}$ $\mu\text{A}$
$V_{FLOAT}$	BAT Regulated Output Voltage	LTC3559 $0^\circ\text{C} \leq T_A \leq 85^\circ\text{C}$ , LTC3559	4.179	4.200	4.221	V
		LTC3559-1 $0^\circ\text{C} \leq T_A \leq 85^\circ\text{C}$ , LTC3559-1	4.165	4.200	4.235	V
$I_{CHG}$	Constant-Current Mode Charge Current	HPWR = 5V	● 440	460	500	mA
		HPWR = 0V	84	92	100	mA
$I_{BAT}$	Battery Drain Current	Standby Mode, Charger Terminated		-3.5	-7	$\mu\text{A}$
		Shutdown, $V_{CC} < V_{UVLO}$ , $BAT = V_{FLOAT}$		-2.5	-4	$\mu\text{A}$
		Suspend Mode, $SUSP = 5\text{V}$ , $BAT = V_{FLOAT}$		-1.5	-3	$\mu\text{A}$
$V_{UVLO}$	Undervoltage Lockout Threshold	$BAT = 3.5\text{V}$ , $V_{CC}$ Rising	3.85	4.0	4.125	V
$\Delta V_{UVLO}$	Undervoltage Lockout Hysteresis	$BAT = 3.5\text{V}$		200		mV
$V_{DUVLO}$	Differential Undervoltage Lockout Threshold	$BAT = 4.05\text{V}$ , ( $V_{CC} - BAT$ ) Falling (LTC3559)	30	50	70	mV
		$BAT = 3.95\text{V}$ , ( $V_{CC} - BAT$ ) Falling (LTC3559-1)	30	50	70	mV

3559fb

## ELECTRICAL CHARACTERISTICS

The ● denotes specifications that apply over the full operating temperature range, otherwise specifications are at  $T_A = 25^\circ\text{C}$ .

SYMBOL	PARAMETER	CONDITIONS	MIN	TYP	MAX	UNITS
$\Delta V_{DUVLO}$	Differential Undervoltage Lockout Hysteresis	BAT = 4.05V (LTC3559) BAT = 3.95V (LTC3559-1)		130 130		mV mV
$V_{PROG}$	PROG Pin Servo Voltage	HPWR = 5V HPWR = 0V BAT < $V_{TRKL}$		1.000 0.200 0.100		V V V
$h_{PROG}$	Ratio of $I_{BAT}$ to PROG Pin Current			800		mA/mA
$I_{TRKL}$	Trickle Charge Current	BAT < $V_{TRKL}$	36	46	56	mA
$V_{TRKL}$	Trickle Charge Threshold Voltage	BAT Rising	2.8	2.9	3.0	V
$\Delta V_{TRKL}$	Trickle Charge Hysteresis Voltage			100		mV
$\Delta V_{RECHRG}$	Recharge Battery Threshold Voltage	Threshold Voltage Relative to $V_{FLOAT}$	-85	-100	-130	mV
$t_{RECHRG}$	Recharge Comparator Filter Time	BAT Falling		1.7		ms
$t_{TERM}$	Safety Timer Termination Period	BAT = $V_{FLOAT}$	3.5	4	4.5	Hour
$t_{BADBAT}$	Bad Battery Termination Time	BAT < $V_{TRKL}$	0.4	0.5	0.6	Hour
$h_{C/10}$	End-of-Charge Indication Current Ratio	(Note 5)	0.085	0.1	0.11	mA/mA
$t_{C/10}$	End-of-Charge Comparator Filter Time	$I_{BAT}$ Falling		2.2		ms
$R_{ON(CHG)}$	Battery Charger Power FET On-Resistance (Between $V_{CC}$ and BAT)	$I_{BAT} = 190\text{mA}$		500		$\text{m}\Omega$
$T_{LIM}$	Junction Temperature in Constant Temperature Mode			105		$^\circ\text{C}$

### NTC

$V_{COLD}$	Cold Temperature Fault Threshold Voltage	Rising NTC Voltage Hysteresis		75 76.5 1.6	78	$\%V_{CC}$ $\%V_{CC}$
$V_{HOT}$	Hot Temperature Fault Threshold Voltage	Falling NTC Voltage Hysteresis		33.4 34.9 1.6	36.4	$\%V_{CC}$ $\%V_{CC}$
$V_{DIS}$	NTC Disable Threshold Voltage	Falling NTC Voltage Hysteresis	●	0.7 1.7 50	2.7	$\%V_{CC}$ mV
$I_{NTC}$	NTC Leakage Current	$V_{NTC} = V_{CC} = 5\text{V}$		-1	1	$\mu\text{A}$

### Logic (HPWR, SUSP, CHRG)

$V_{IL}$	Input Low Voltage	HPWR, SUSP Pins			0.4	V
$V_{IH}$	Input High Voltage	HPWR, SUSP Pins		1.2		V
$R_{DN}$	Logic Pin Pull-Down Resistance	HPWR, SUSP Pins	●	1.9	4	6.3 $\text{M}\Omega$
$V_{CHRG}$	$\overline{\text{CHRG}}$ Pin Output Low Voltage	$I_{CHRG} = 5\text{mA}$			100	250 mV
$I_{CHRG}$	$\overline{\text{CHRG}}$ Pin Input Current	BAT = 4.5V, $V_{CHRG} = 5\text{V}$			0	1 $\mu\text{A}$

### Buck Switching Regulators, BAT = $PV_{IN} = 3.8\text{V}$ , EN1 = EN2 = 3.8V

$PV_{IN}$	Input Supply Voltage	LTC3559 LTC3559-1	● ●	3 3	4.2 4.1	V V
$I_{PVIN}$	Pulse Skip Supply Current Burst Mode Supply Current Shutdown Supply Current Supply Current in UVLO	MODE = 0 (One Buck Enabled) (Note 6) MODE = 1 (One Buck Enabled) (Note 6) EN1 = EN2 = 0V $PV_{IN} = 2.0\text{V}$	●		220 35 0 4	400 50 2 8 $\mu\text{A}$ $\mu\text{A}$ $\mu\text{A}$ $\mu\text{A}$
$PV_{IN\ UVLO}$	$PV_{IN}$ Falling $PV_{IN}$ Rising				2.45 2.55	V V
$f_{OSC}$	Switching Frequency	MODE = 0V		1.91	2.25	2.59 MHz
$V_{IL}$	Input Low Voltage	MODE, EN1, EN2			0.4	V
$V_{IH}$	Input High Voltage	MODE, EN1, EN2		1.2		V
$I_{LIMSW}$	Peak PMOS Current Limit	MODE = 0V or 3.8V		550	800	1050 mA

# LTC3559/LTC3559-1

## ELECTRICAL CHARACTERISTICS

The ● denotes specifications that apply over the full operating temperature range, otherwise specifications are at  $T_A = 25^\circ\text{C}$ .

SYMBOL	PARAMETER	CONDITIONS	MIN	TYP	MAX	UNITS
$V_{FB}$	Feedback Voltage		● 780	800	820	mV
$I_{FB}$	FB Input Current	FB1, FB2 = 0.82V	-0.05		0.05	$\mu\text{A}$
$D_{MAX}$	Maximum Duty Cycle	FB1, FB2 = 0V	100			%
$R_{PMOS}$	$R_{DS(ON)}$ of PMOS	$I_{SW} = 150\text{mA}$		0.65		$\Omega$
$R_{NMOS}$	$R_{DS(ON)}$ of NMOS	$I_{SW} = -150\text{mA}$		0.75		$\Omega$
$R_{SW(PD)}$	SW Pull-Down in Shutdown			13		$\text{k}\Omega$

**Note 1:** Stresses beyond those listed under Absolute Maximum Ratings may cause permanent damage to the device. Exposure to any Absolute Maximum Rating condition for extended periods may affect device reliability and lifetime.

**Note 2:**  $T_J$  is calculated from the ambient temperature  $T_A$  and power dissipation  $P_D$  according to the following formula:

$$T_J = T_A + (P_D \cdot \theta_{JA})^\circ\text{C/W}$$

**Note 3:** The LTC3559/LTC3559-1 are guaranteed to meet specifications from  $0^\circ\text{C}$  to  $85^\circ\text{C}$ . Specifications over the  $-40^\circ\text{C}$  to  $85^\circ\text{C}$  operating

temperature range are assured by design, characterization and correlation with statistical process controls.

**Note 4:**  $V_{CC}$  supply current does not include current through the PROG pin or any current delivered to the BAT pin. Total input current is equal to this specification plus  $1.00125 \cdot I_{BAT}$  where  $I_{BAT}$  is the charge current.

**Note 5:**  $I_{C/10}$  is expressed as a fraction of measured full charge current with indicated PROG resistor.

**Note 6:** FB high, regulator not switching.

## TYPICAL PERFORMANCE CHARACTERISTICS

Suspend State Supply and BAT Currents vs Temperature

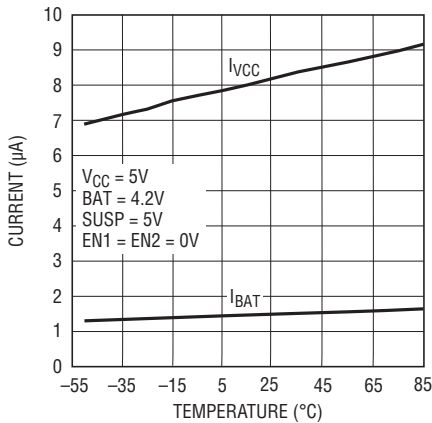

3559 G01

Battery Regulation (Float) Voltage vs Temperature

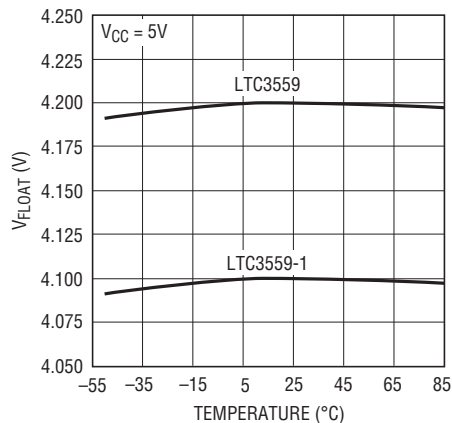

3559 G02

Battery Regulation (Float) Voltage vs Battery Charge Current, Constant-Voltage Charging

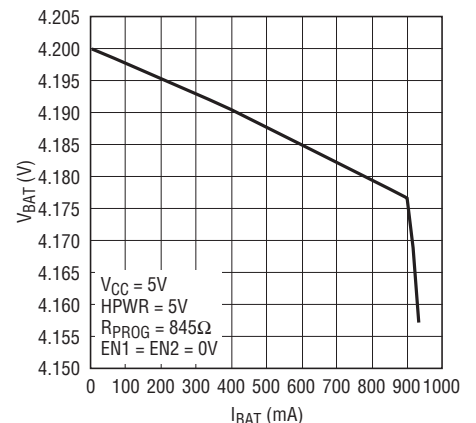

3559 G03

3559fb

# TYPICAL PERFORMANCE CHARACTERISTICS

**Battery Charge Current vs Supply Voltage**

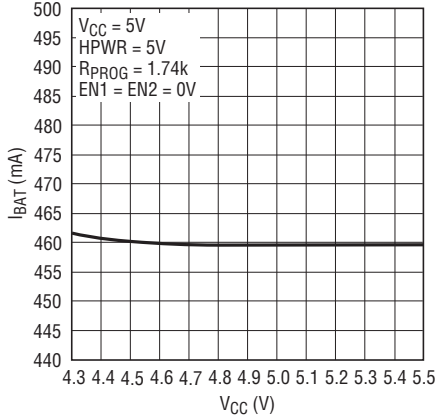

3559 G04

**Battery Charge Current vs Battery Voltage (LTC3559)**

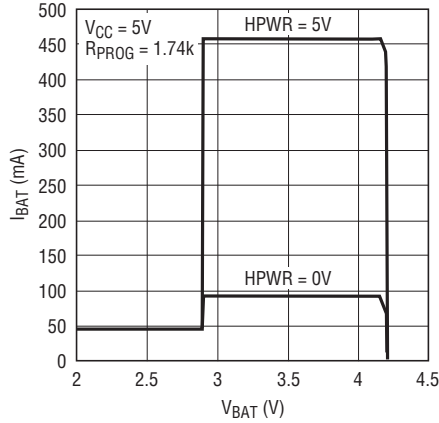

3559 G05

**Battery Charge Current vs Ambient Temperature in Thermal Regulation**

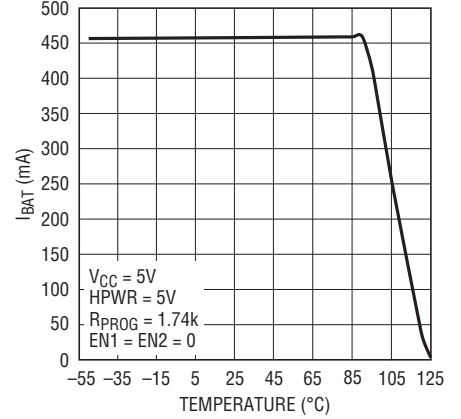

3559 G06

**Battery Charger Undervoltage Lockout Threshold vs Temperature**

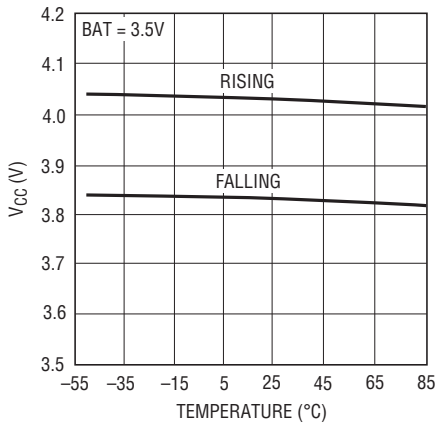

3559 G07

**Battery Drain Current in Undervoltage Lockout vs Temperature**

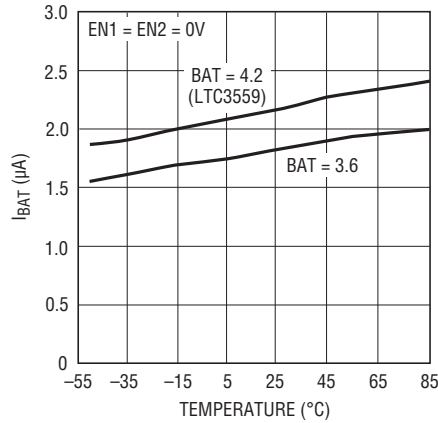

3559 G08

**PROG Voltage vs Battery Charge Current**

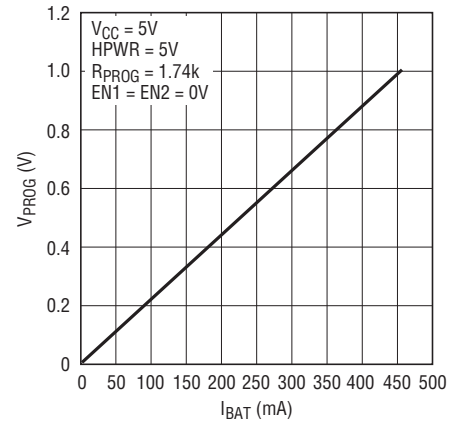

3559 G09

**Recharge Threshold vs Temperature**

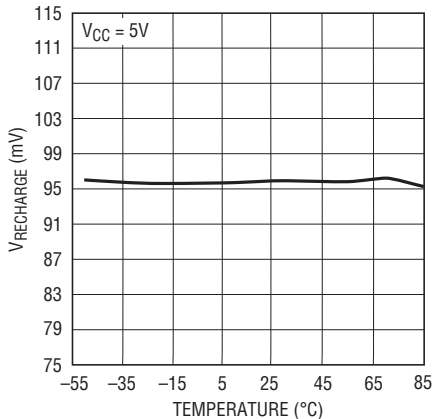

3559 G10

**Battery Charger FET On-Resistance vs Temperature**

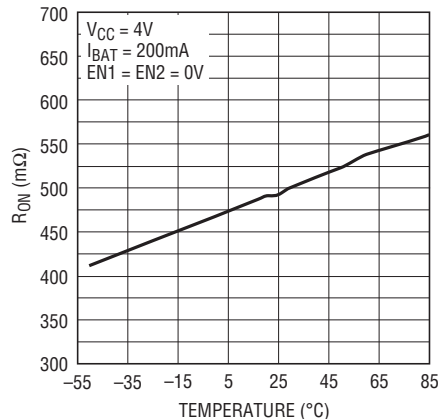

3559 G11

**SUSP/HPWR Pin Rising Thresholds vs Temperature**

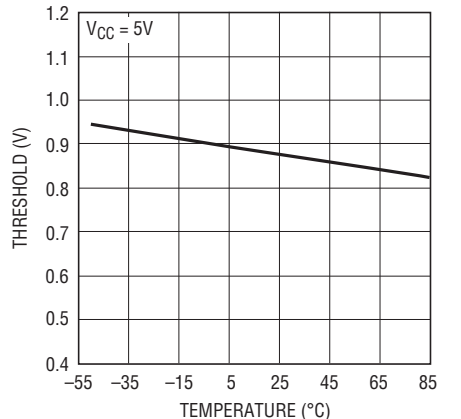

3559 G12

## TYPICAL PERFORMANCE CHARACTERISTICS

**CHRG Pin Output Low Voltage vs Temperature**

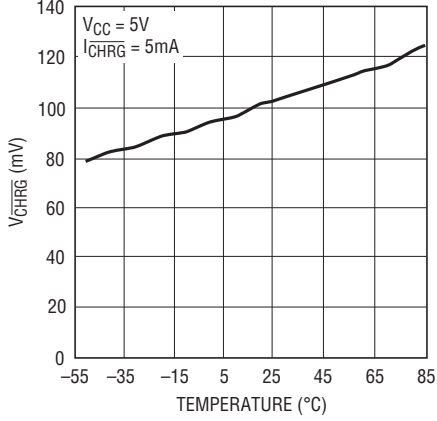

3559 G13

**CHRG Pin I-V Curve**

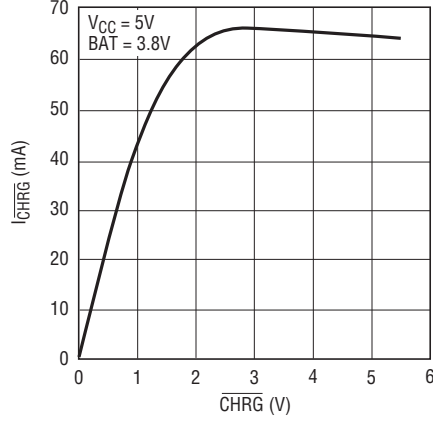

3559 G14

**Timer Accuracy vs Supply Voltage**

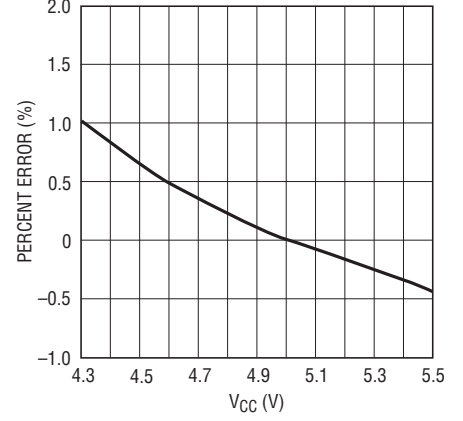

3559 G15

**Timer Accuracy vs Temperature**

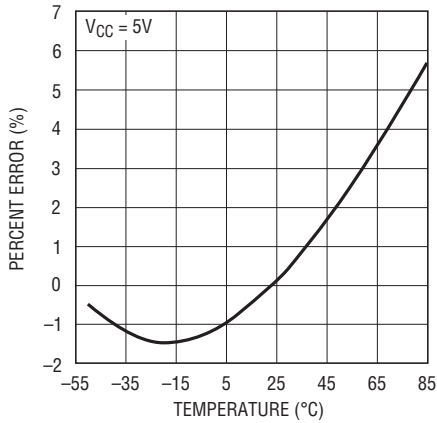

3559 G16

**Complete Charge Cycle  
2400mAh Battery (LTC3559)**

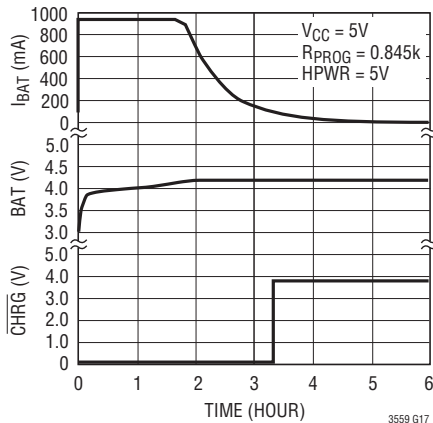

3559 G17

**Buck Regulator Input Current vs  
Temperature, Burst Mode Operation**

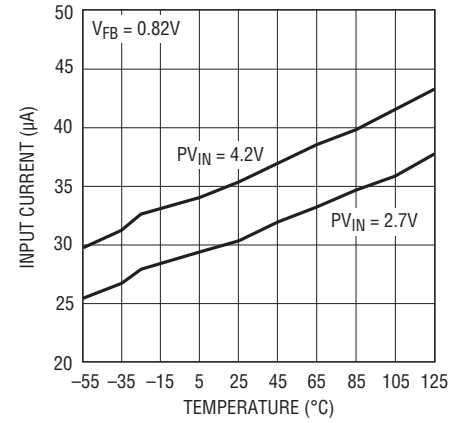

3559 G18

**Buck Regulator Input Current vs  
Temperature, Pulse Skip Mode  
(LTC3559)**

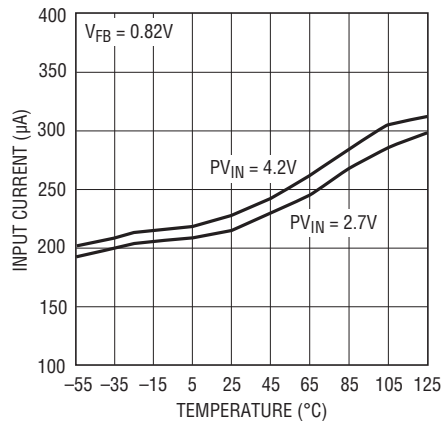

3559 G19

**Buck Regulator  $PV_{IN}$  Undervoltage  
Thresholds vs Temperature**

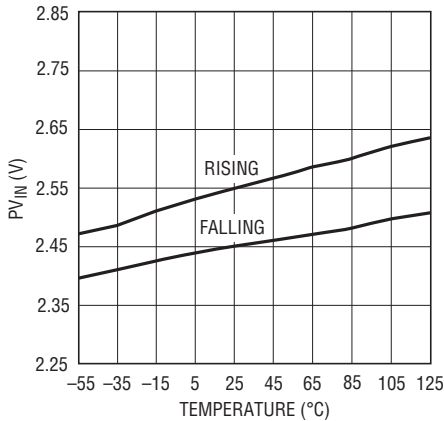

3559 G20

**Frequency vs Temperature**

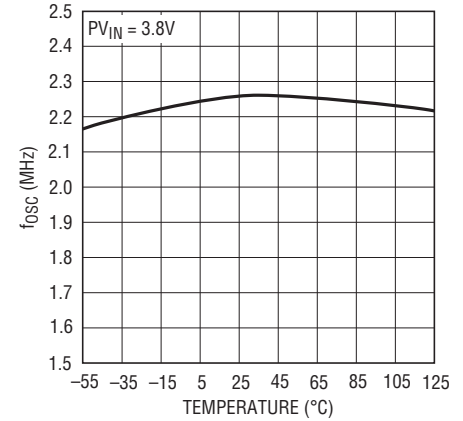

3559 G21

3559fb

# TYPICAL PERFORMANCE CHARACTERISTICS

**Buck Regulator Enable Thresholds vs Temperature**

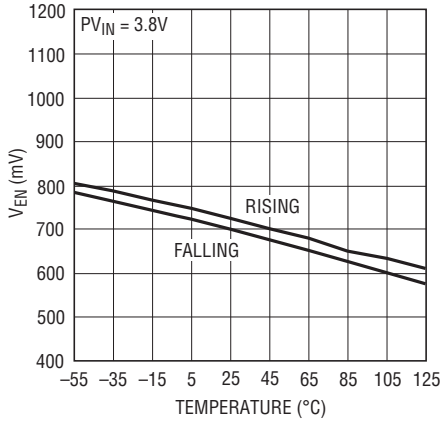

3559 G22

**Buck Regulator PMOS  $R_{DS(ON)}$  vs Temperature (LTC3559)**

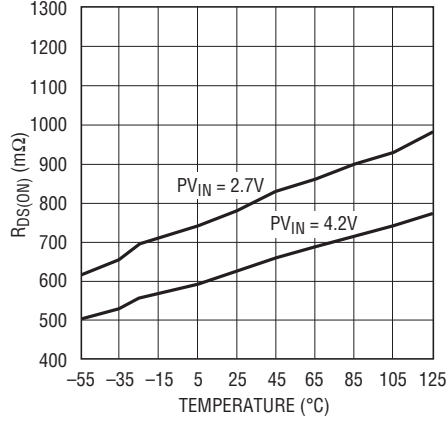

3559 G23

**Buck Regulator NMOS  $R_{DS(ON)}$  vs Temperature (LTC3559)**

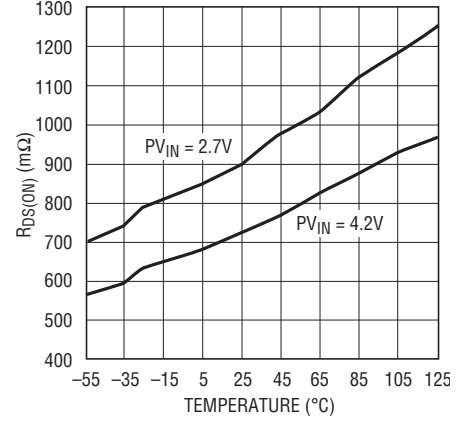

3559 G24

**Buck Regulator Efficiency vs  $I_{LOAD}$  (LTC3559)**

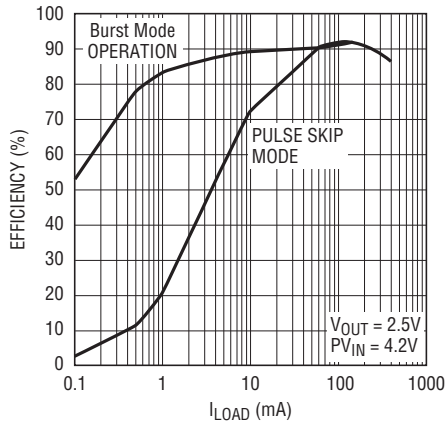

3559 G25

**Buck Regulator Load Regulation**

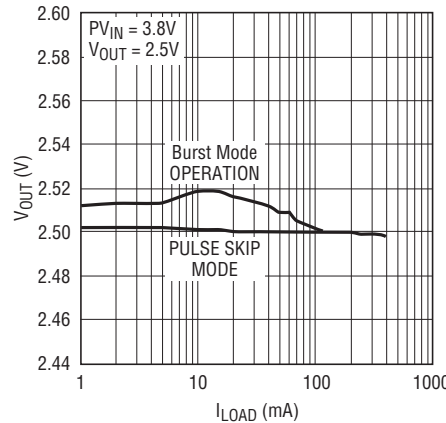

3559 G26

**Buck Regulator Line Regulation**

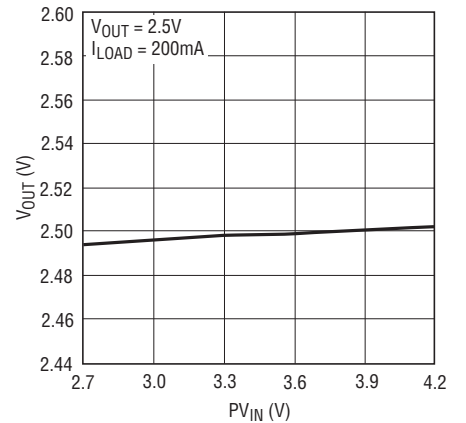

3559 G27

**Buck Regulator Efficiency vs  $I_{LOAD}$  (LTC3559)**

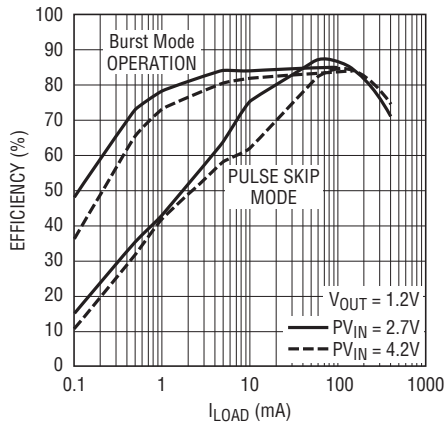

3559 G28

**Buck Regulator Load Regulation**

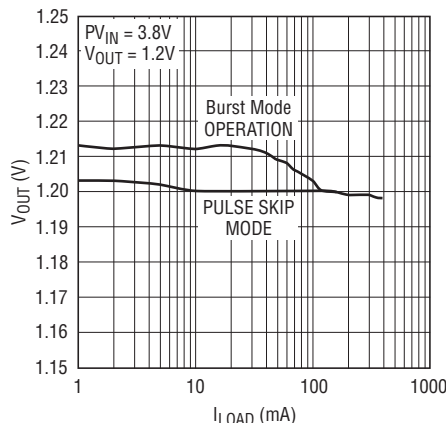

3559 G29

**Buck Regulator Line Regulation**

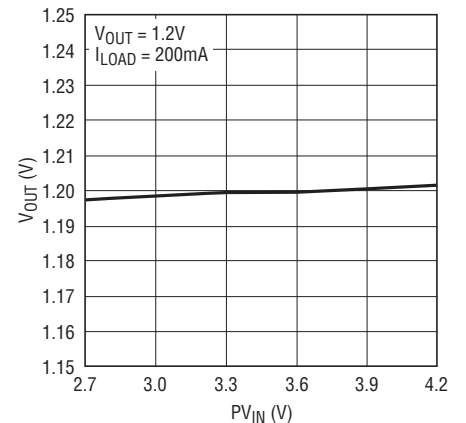

3559 G30

## TYPICAL PERFORMANCE CHARACTERISTICS

### Buck Regulator Start-Up Transient

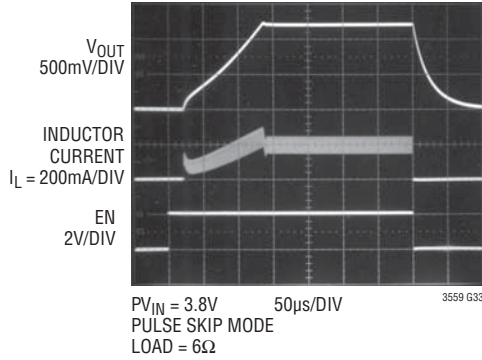

### Buck Regulator Pulse Skip Mode Operation

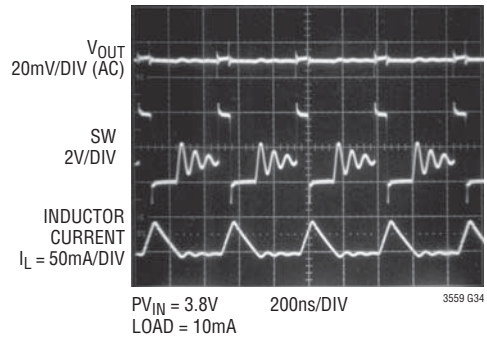

### Buck Regulator Burst Mode Operation

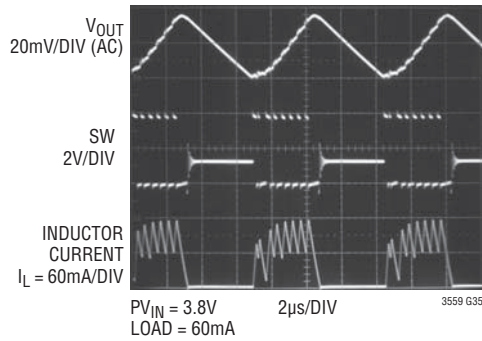

### Buck Regulator Transient Response, Pulse Skip Mode

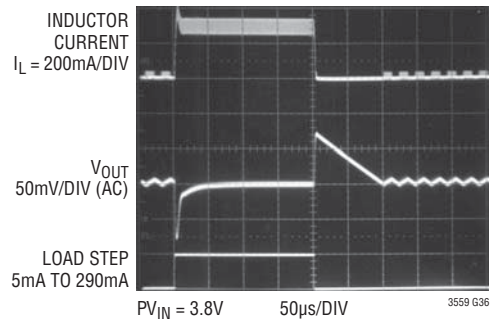

### Buck Regulator Transient Response, Burst Mode Operation

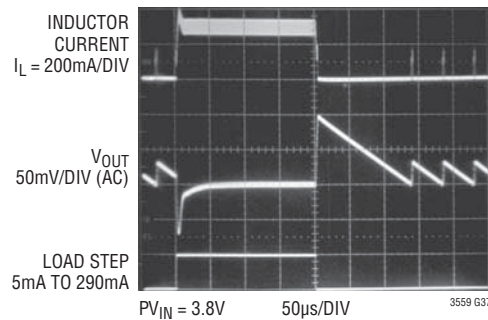

## PIN FUNCTIONS

**GND (Pin 1):** Ground, Connect to Exposed Pad (Pin 17).

**BAT (Pin 2):** Charge Current Output. Provides charge current to the battery and regulates final float voltage to 4.2V (LTC3559) or 4.1V (LTC3559-1).

**MODE (Pin 3):** MODE Pin for Buck Regulators. When held high, both regulators are in Burst Mode operation. When held low both regulators operate in pulse skip mode. This pin is a high impedance input; do not float.

**FB1 (Pin 4):** Buck 1 Feedback Voltage Pin. Receives feedback by a resistor divider connected across the output.

**EN1 (Pin 5):** Enable Input Pin for Buck 1. This pin is a high impedance input; do not float. Active high.

**SW1 (Pin 6):** Buck 1 Switching Node. External inductor connects to this node.

**PV<sub>IN</sub> (Pin 7):** Input Supply Pin for Buck Regulators. Connect to BAT. A 2.2μF decoupling capacitor to GND is recommended.

**SW2 (Pin 8):** Buck 2 Switching Node. External inductor connects to this node.

**EN2 (Pin 9):** Enable Input Pin for Buck 2. This pin is a high impedance input; do not float. Active high.

**FB2 (Pin 10):** Buck 2 Feedback Voltage Pin. Receives feedback by a resistor divider connected across the output.

**SUSP (Pin 11):** Suspend Battery Charging Operation. A voltage greater than 1.2V on this pin puts the battery charger into suspend mode, disables the charger and resets the termination timer. A weak pull-down current is internally applied to this pin to ensure it is low at power up when the input is not being driven externally.

**HPWR (Pin 12):** High Current Battery Charging Enabled. A voltage greater than 1.2V at this pin programs the BAT pin current at 100% of the maximum programmed charge current. A voltage less than 0.4V sets the BAT pin current to 20% of the maximum programmed charge current. When used with a 1.74k PROG resistor, this pin

can toggle between low power and high power modes per USB specification. A weak pull-down current is internally applied to this pin to ensure it is low at power up when the input is not being driven externally.

**NTC (Pin 13):** Input to the NTC Thermistor Monitoring Circuit. The NTC pin connects to a negative temperature coefficient thermistor which is typically co-packaged with the battery pack to determine if the battery is too hot or too cold to charge. If the battery temperature is out of range, charging is paused until the battery temperature re-enters the valid range. A low drift bias resistor is required from V<sub>CC</sub> to NTC and a thermistor is required from NTC to ground. To disable the NTC function, the NTC pin should be grounded.

**PROG (Pin 14):** Charge Current Program and Charge Current Monitor Pin. Charge current is programmed by connecting a resistor from PROG to ground. When charging in constant-current mode, the PROG pin serves to 1V if the HPWR pin is pulled high, or 200mV if the HPWR pin is pulled low. The voltage on this pin always represents the battery current through the following formula:

$$I_{\text{BAT}} = \frac{\text{PROG}}{R_{\text{PROG}}} \cdot 800$$

**CHRG (Pin 15):** Open-Drain Charge Status Output. The CHRG pin indicates the status of the battery charger. Four possible states are represented by CHRG: charging, not charging (i.e., the charge current is less than 1/10th of the full-scale charge current), unresponsive battery (i.e., the battery voltage remains below 2.9V after 1/2 hour of charging) and battery temperature out of range. CHRG requires a pull-up resistor and/or LED to provide indication.

**V<sub>CC</sub> (Pin 16):** Battery Charger Input. A 1μF decoupling capacitor to GND is recommended.

**Exposed Pad (Pin 17):** Ground. The Exposed Pad must be soldered to PCB ground to provide electrical contact and rated thermal performance.

**BLOCK DIAGRAM**

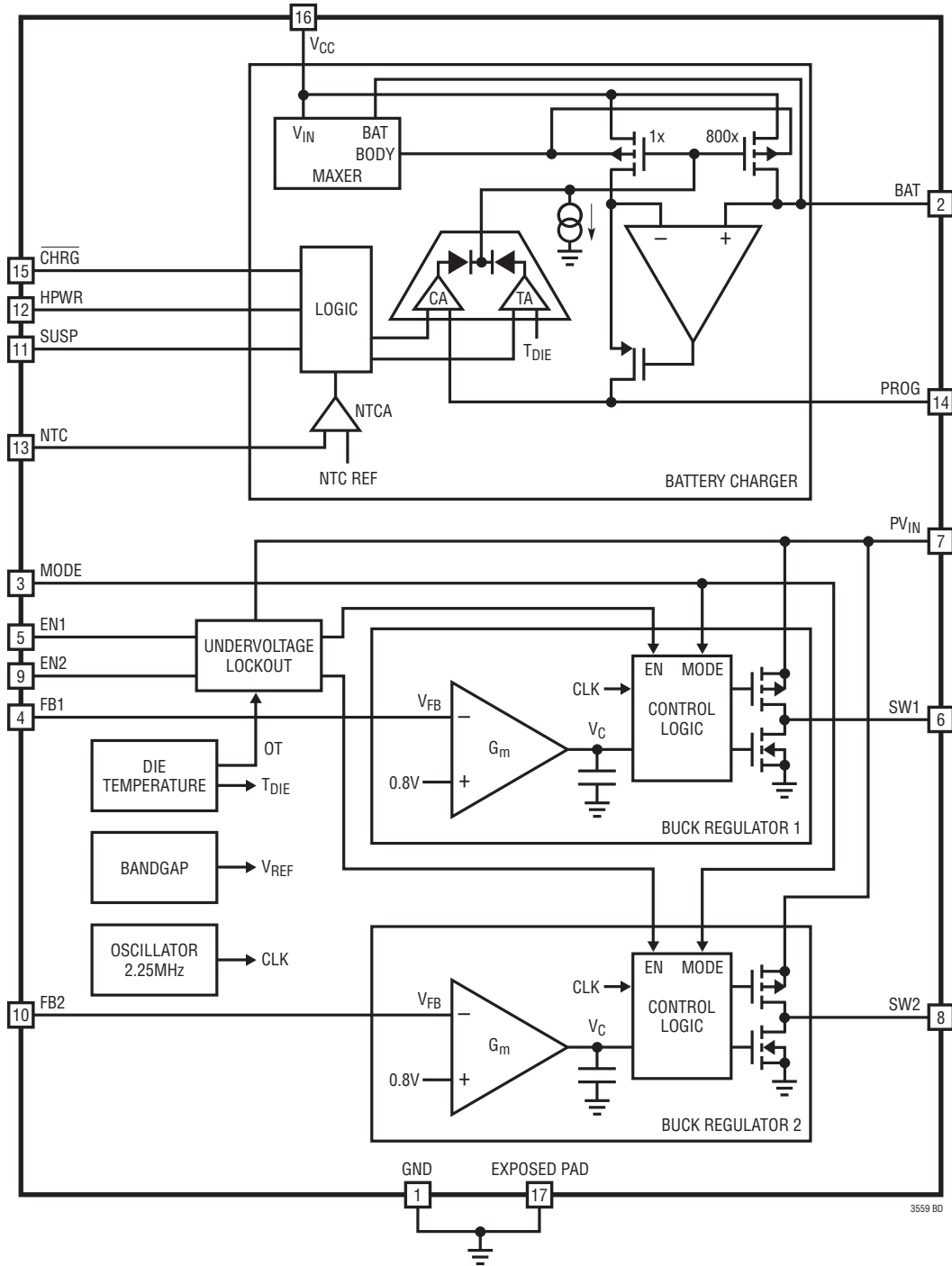

3559 BD

## OPERATION

The LTC3559/LTC3559-1 are linear battery chargers with dual monolithic synchronous buck regulators. The buck regulators are internally compensated and need no external compensation components.

The battery charger employs a constant-current/constant-voltage charging algorithm and is capable of charging a single Li-Ion battery at charging currents up to 950mA. The user can program the maximum charging current available

at the BAT pin via a single PROG resistor. The actual BAT pin current is set by the status of the HPWR pin.

For proper operation, the BAT and PV<sub>IN</sub> pins must be tied together. If a buck regulator is also enabled during the battery charging operation, the net current charging the battery may be lower than the actual programmed value. Refer to Figure 1 for an explanation.

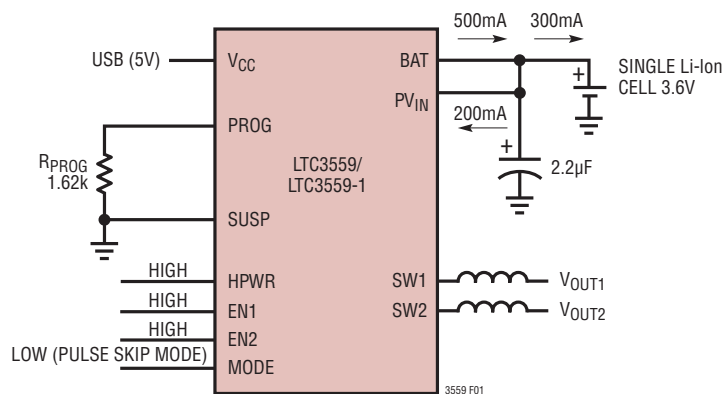

**Figure 1. Current Being Delivered at the BAT Pin Is 500mA. Both Buck Regulators Are Enabled. The Sum of the Average Input Currents Drawn by Both Buck Regulators Is 200mA. This Makes the Effective Battery Charging Current Only 300mA. If the HPWR Pin Were Tied LO, the BAT Pin Current Would Be 100mA. With the Buck Regulator Conditions Unchanged, This Would Cause the Battery to Discharge at 100mA**

## APPLICATIONS INFORMATION

### Battery Charger Introduction

The LTC3559/LTC3559-1 have a linear battery charger designed to charge single-cell lithium-ion batteries. The charger uses a constant-current/constant-voltage charge algorithm with a charge current programmable up to 950mA. Additional features include automatic recharge, an internal termination timer, low-battery trickle charge conditioning, bad-battery detection, and a thermistor sensor input for out of temperature charge pausing.

Furthermore, the battery charger is capable of operating from a USB power source. In this application, charge current can be programmed to a maximum of 100mA or 500mA per USB power specifications.

### Input Current vs Charge Current

The battery charger regulates the total current delivered to the BAT pin; this is the charge current. To calculate the total input current (i.e., the total current drawn from the V<sub>CC</sub> pin), it is necessary to sum the battery charge current, charger quiescent current and PROG pin current.

### Undervoltage Lockout (UVLO)

The undervoltage lockout circuit monitors the input voltage (V<sub>CC</sub>) and disables the battery charger until V<sub>CC</sub> rises above V<sub>UVLO</sub> (typically 4V). 200mV of hysteresis prevents oscillations around the trip point. In addition, a differential undervoltage lockout circuit disables the battery charger when V<sub>CC</sub> falls to within V<sub>DUVLO</sub> (typically 50mV) of the BAT voltage.

## APPLICATIONS INFORMATION

### Suspend Mode

The battery charger can also be disabled by pulling the SUSP pin above 1.2V. In suspend mode, the battery drain current is reduced to 1.5 $\mu$ A and the input current is reduced to 8.5 $\mu$ A.

### Charge Cycle Overview

When a battery charge cycle begins, the battery charger first determines if the battery is deeply discharged. If the battery voltage is below  $V_{TRKL}$ , typically 2.9V, an automatic trickle charge feature sets the battery charge current to 10% of the full-scale value.

Once the battery voltage is above 2.9V, the battery charger begins charging in constant-current mode. When the battery voltage approaches the 4.2V (LTC3559) or 4.1V (LTC3559-1) required to maintain a full charge, otherwise known as the float voltage, the charge current begins to decrease as the battery charger switches into constant-voltage mode.

### Trickle Charge and Defective Battery Detection

Any time the battery voltage is below  $V_{TRKL}$ , the charger goes into trickle charge mode and reduces the charge current to 10% of the full-scale current. If the battery voltage remains below  $V_{TRKL}$  for more than 1/2 hour, the charger latches the bad-battery state, automatically terminates, and indicates via the  $\overline{CHRG}$  pin that the battery was unresponsive. If for any reason the battery voltage rises above  $V_{TRKL}$ , the charger will resume charging. Since the charger has latched the bad-battery state, if the battery voltage then falls below  $V_{TRKL}$  again but without rising past  $V_{RECHRG}$  first, the charger will immediately assume that the battery is defective. To reset the charger (i.e., when the dead battery is replaced with a new battery), simply remove the input voltage and reapply it or put the part in and out of suspend mode.

### Charge Termination

The battery charger has a built-in safety timer that sets the total charge time for 4 hours. Once the battery voltage rises above  $V_{RECHRG}$  and the charger enters constant-voltage

mode, the 4-hour timer is started. After the safety timer expires, charging of the battery will discontinue and no more current will be delivered.

### Automatic Recharge

After the battery charger terminates, it will remain off, drawing only microamperes of current from the battery. If the portable product remains in this state long enough, the battery will eventually self discharge. To ensure that the battery is always topped off, a charge cycle will automatically begin when the battery voltage falls below  $V_{RECHRG}$ . In the event that the safety timer is running when the battery voltage falls below  $V_{RECHRG}$ , it will reset back to zero. To prevent brief excursions below  $V_{RECHRG}$  from resetting the safety timer, the battery voltage must be below  $V_{RECHRG}$  for more than 1.7ms. The charge cycle and safety timer will also restart if the  $V_{CC}$  UVLO or DUVLO cycles low and then high (e.g.,  $V_{CC}$  is removed and then replaced) or the charger enters and then exits suspend mode.

### Programming Charge Current

The PROG pin serves both as a charge current program pin, and as a charge current monitor pin. By design, the PROG pin current is 1/800th of the battery charge current. Therefore, connecting a resistor from PROG to ground programs the charge current while measuring the PROG pin voltage allows the user to calculate the charge current.

Full-scale charge current is defined as 100% of the constant-current mode charge current programmed by the PROG resistor. In constant-current mode, the PROG pin serves to 1V if HPWR is high, which corresponds to charging at the full-scale charge current, or 200mV if HPWR is low, which corresponds to charging at 20% of the full-scale charge current. Thus, the full-scale charge current and desired program resistor for a given full-scale charge current are calculated using the following equations:

$$I_{CHG} = \frac{800V}{R_{PROG}}$$

$$R_{PROG} = \frac{800V}{I_{CHG}}$$

## APPLICATIONS INFORMATION

In any mode, the actual battery current can be determined by monitoring the PROG pin voltage and using the following equation:

$$I_{\text{BAT}} = \frac{\text{PROG}}{R_{\text{PROG}}} \cdot 800$$

### Thermal Regulation

To prevent thermal damage to the IC or surrounding components, an internal thermal feedback loop will automatically decrease the programmed charge current if the die temperature rises to approximately 115°C. Thermal regulation protects the battery charger from excessive temperature due to high power operation or high ambient thermal conditions and allows the user to push the limits of the power handling capability with a given circuit board design without risk of damaging the LTC3559/LTC3559-1 or external components. The benefit of the LTC3559/LTC3559-1 battery charger thermal regulation loop is that charge current can be set according to actual conditions rather than worst-case conditions with the assurance that the battery charger will automatically reduce the current in worst-case conditions.

### Charge Status Indication

The  $\overline{\text{CHRG}}$  pin indicates the status of the battery charger. Four possible states are represented by  $\overline{\text{CHRG}}$ : charging, not charging, unresponsive battery and battery temperature out of range.

The signal at the  $\overline{\text{CHRG}}$  pin can be easily recognized as one of the above four states by either a human or a microprocessor. The  $\overline{\text{CHRG}}$  pin, which is an open-drain output, can drive an indicator LED through a current limiting resistor for human interfacing, or simply a pull-up resistor for microprocessor interfacing.

To make the  $\overline{\text{CHRG}}$  pin easily recognized by both humans and microprocessors, the pin is either low for charging, high for not charging, or it is switched at high frequency (35kHz) to indicate the two possible faults: unresponsive battery and battery temperature out of range.

When charging begins,  $\overline{\text{CHRG}}$  is pulled low and remains low for the duration of a normal charge cycle. When the

charge current has dropped to below 10% of the full-scale current, the  $\overline{\text{CHRG}}$  pin is released (high impedance). If a fault occurs after the  $\overline{\text{CHRG}}$  pin is released, the pin remains high impedance. However, if a fault occurs before the  $\overline{\text{CHRG}}$  pin is released, the pin is switched at 35kHz. While switching, its duty cycle is modulated between a high and low value at a very low frequency. The low and high duty cycles are disparate enough to make an LED appear to be on or off thus giving the appearance of “blinking”. Each of the two faults has its own unique “blink” rate for human recognition as well as two unique duty cycles for microprocessor recognition.

Table 1 illustrates the four possible states of the  $\overline{\text{CHRG}}$  pin when the battery charger is active.

**Table 1.  $\overline{\text{CHRG}}$  Output Pin**

STATUS	FREQUENCY	MODULATION (BLINK) FREQUENCY	DUTY CYCLE
Charging	0Hz	0 Hz (Lo-Z)	100%
$I_{\text{BAT}} < C/10$	0Hz	0 Hz (Hi-Z)	0%
NTC Fault	35kHz	1.5Hz at 50%	6.25% to 93.75%
Bad Battery	35kHz	6.1Hz at 50%	12.5% to 87.5%

An NTC fault is represented by a 35kHz pulse train whose duty cycle varies between 6.25% and 93.75% at a 1.5Hz rate. A human will easily recognize the 1.5Hz rate as a “slow” blinking which indicates the out of range battery temperature while a microprocessor will be able to decode either the 6.25% or 93.75% duty cycles as an NTC fault.

If a battery is found to be unresponsive to charging (i.e., its voltage remains below  $V_{\text{TRKL}}$  for over 1/2 hour), the  $\overline{\text{CHRG}}$  pin gives the battery fault indication. For this fault, a human would easily recognize the frantic 6.1Hz “fast” blinking of the LED while a microprocessor would be able to decode either the 12.5% or 87.5% duty cycles as a bad battery fault.

Although very improbable, it is possible that a duty cycle reading could be taken at the bright-dim transition (low duty cycle to high duty cycle). When this happens the duty cycle reading will be precisely 50%. If the duty cycle reading is 50%, system software should disqualify it and take a new duty cycle reading.

## APPLICATIONS INFORMATION

### NTC Thermistor

The battery temperature is measured by placing a negative temperature coefficient (NTC) thermistor close to the battery pack. The NTC circuitry is shown in Figure 3.

To use this feature, connect the NTC thermistor,  $R_{NTC}$ , between the NTC pin and ground, and a bias resistor,  $R_{NOM}$ , from  $V_{CC}$  to NTC.  $R_{NOM}$  should be a 1% resistor with a value equal to the value of the chosen NTC thermistor at 25°C ( $R_{25}$ ). A 100k thermistor is recommended since thermistor current is not measured by the battery charger and its current will have to be considered for compliance with USB specifications.

The battery charger will pause charging when the resistance of the NTC thermistor drops to 0.54 times the

value of  $R_{25}$  or approximately 54k (for a Vishay “Curve 1” thermistor, this corresponds to approximately 40°C). If the battery charger is in constant-voltage mode, the safety timer will pause until the thermistor indicates a return to a valid temperature.

As the temperature drops, the resistance of the NTC thermistor rises. The battery charger is also designed to pause charging when the value of the NTC thermistor increases to 3.25 times the value of  $R_{25}$ . For a Vishay “Curve 1” thermistor, this resistance, 325k, corresponds to approximately 0°C. The hot and cold comparators each have approximately 3°C of hysteresis to prevent oscillation about the trip point. Grounding the NTC pin disables all NTC functionality.

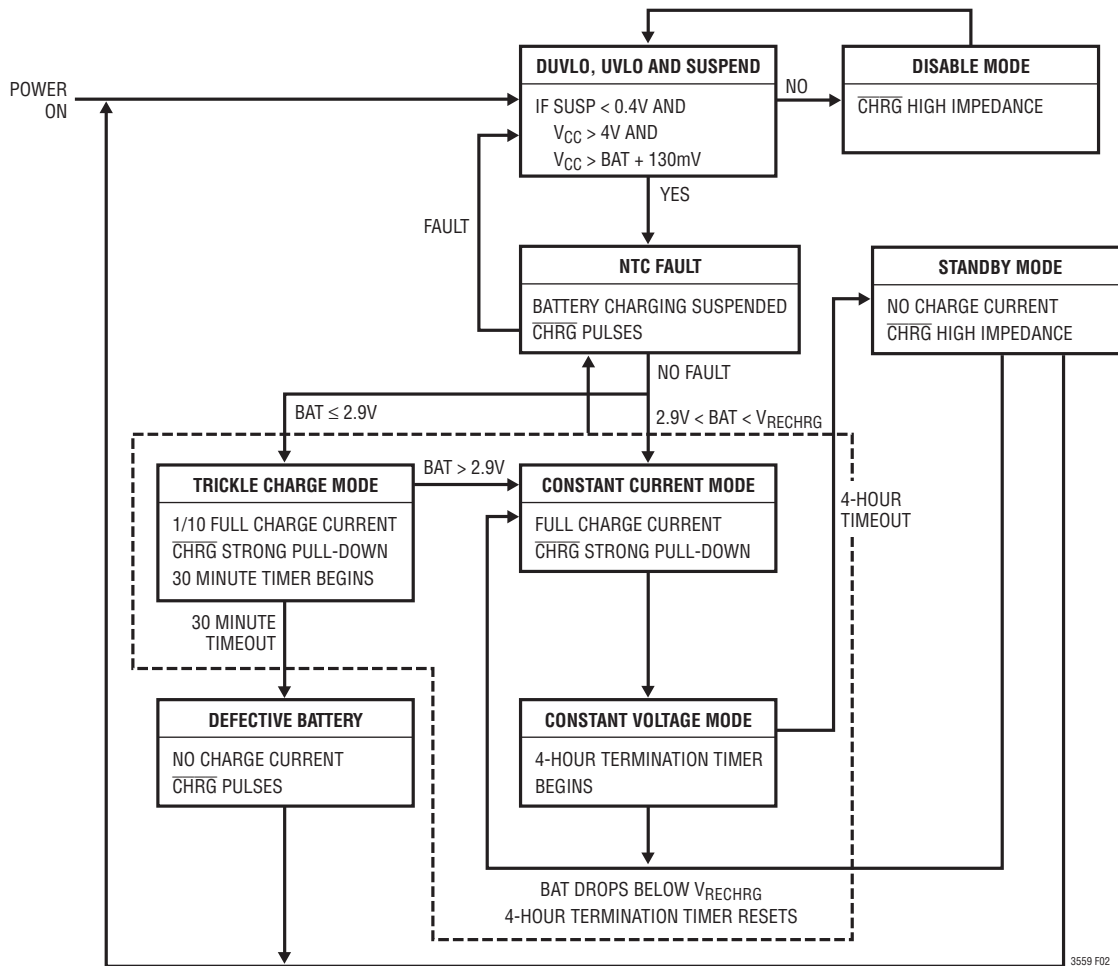

Figure 2. State Diagram of the Battery Charger Operation

## APPLICATIONS INFORMATION

### Alternate NTC Thermistors and Biasing

The battery charger provides temperature qualified charging if a grounded thermistor and a bias resistor are connected to the NTC pin. By using a bias resistor whose value is equal to the room temperature resistance of the thermistor ( $R_{25}$ ) the upper and lower temperatures are pre-programmed to approximately 40°C and 0°C, respectively (assuming a Vishay “Curve 1” thermistor).

The upper and lower temperature thresholds can be adjusted by either a modification of the bias resistor value or by adding a second adjustment resistor to the circuit. If only the bias resistor is adjusted, then either the upper or the lower threshold can be modified but not both. The other trip point will be determined by the characteristics of the thermistor. Using the bias resistor in addition to an adjustment resistor, both the upper and the lower temperature trip points can be independently programmed with the constraint that the difference between the upper and lower temperature thresholds cannot decrease. Examples of each technique are given below.

NTC thermistors have temperature characteristics which are indicated on resistance-temperature conversion tables. The Vishay-Dale thermistor NTHS0603N011-N1003F, used in the following examples, has a nominal value of 100k and follows the Vishay “Curve 1” resistance-temperature characteristic.

In the explanation below, the following notation is used.

$R_{25}$  = Value of the thermistor at 25°C

$R_{NTC|COLD}$  = Value of thermistor at the cold trip point

$R_{NTC|HOT}$  = Value of the thermistor at the hot trip point

$r_{COLD}$  = Ratio of  $R_{NTC|COLD}$  to  $R_{25}$

$r_{HOT}$  = Ratio of  $R_{NTC|HOT}$  to  $R_{25}$

$R_{NOM}$  = Primary thermistor bias resistor (see Figure 3)

$R_1$  = Optional temperature range adjustment resistor (see Figure 4)

The trip points for the battery charger’s temperature qualification are internally programmed at  $0.349 \cdot V_{CC}$  for the hot threshold and  $0.765 \cdot V_{CC}$  for the cold threshold.

Therefore, the hot trip point is set when:

$$\frac{R_{NTC|HOT}}{R_{NOM} + R_{NTC|HOT}} \cdot V_{CC} = 0.349 \cdot V_{CC}$$

and the cold trip point is set when:

$$\frac{R_{NTC|COLD}}{R_{NOM} + R_{NTC|COLD}} \cdot V_{CC} = 0.765 \cdot V_{CC}$$

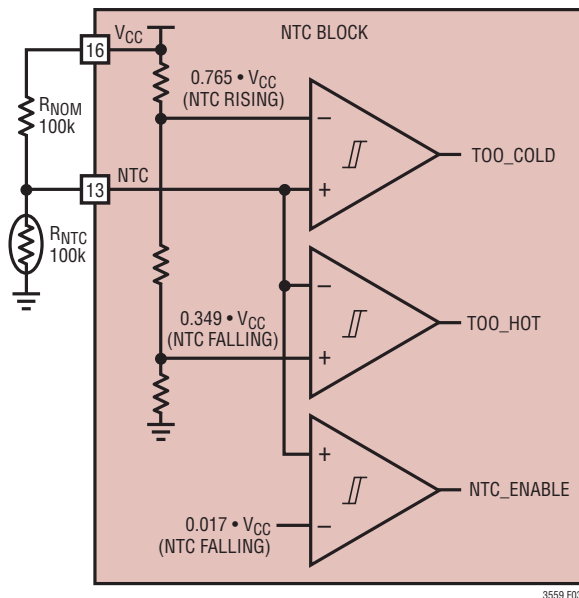

Figure 3. Typical NTC Thermistor Circuit

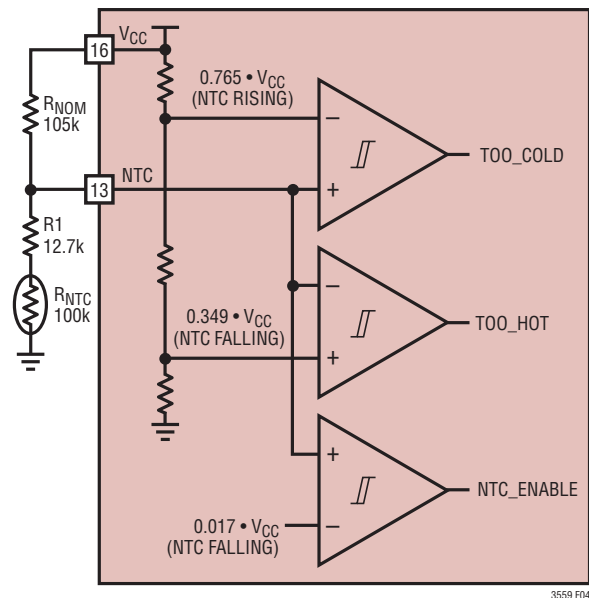

Figure 4. NTC Thermistor Circuit with Additional Bias Resistor

3559fb

## APPLICATIONS INFORMATION

Solving these equations for  $R_{NTC|COLD}$  and  $R_{NTC|HOT}$  results in the following:

$$R_{NTC|HOT} = 0.536 \cdot R_{NOM}$$

and

$$R_{NTC|COLD} = 3.25 \cdot R_{NOM}$$

By setting  $R_{NOM}$  equal to R25, the above equations result in  $r_{HOT} = 0.536$  and  $r_{COLD} = 3.25$ . Referencing these ratios to the Vishay Resistance-Temperature Curve 1 chart gives a hot trip point of about 40°C and a cold trip point of about 0°C. The difference between the hot and cold trip points is approximately 40°C.

By using a bias resistor,  $R_{NOM}$ , different in value from R25, the hot and cold trip points can be moved in either direction. The temperature span will change somewhat due to the nonlinear behavior of the thermistor. The following equations can be used to easily calculate a new value for the bias resistor:

$$R_{NOM} = \frac{r_{HOT}}{0.536} \cdot R25$$

$$R_{NOM} = \frac{r_{COLD}}{3.25} \cdot R25$$

where  $r_{HOT}$  and  $r_{COLD}$  are the resistance ratios at the desired hot and cold trip points. Note that these equations are linked. Therefore, only one of the two trip points can be chosen, the other is determined by the default ratios designed in the IC. Consider an example where a 60°C hot trip point is desired.

From the Vishay Curve 1 R-T characteristics,  $r_{HOT}$  is 0.2488 at 60°C. Using the above equation,  $R_{NOM}$  should be set to 46.4k. With this value of  $R_{NOM}$ , the cold trip point is about 16°C. Notice that the span is now 44°C rather than the previous 40°C.

The upper and lower temperature trip points can be independently programmed by using an additional bias resistor as shown in Figure 4. The following formulas can be used to compute the values of  $R_{NOM}$  and R1:

$$R_{NOM} = \frac{r_{COLD} - r_{HOT}}{2.714} \cdot R25$$

$$R1 = 0.536 \cdot R_{NOM} - r_{HOT} \cdot R25$$

For example, to set the trip points to 0°C and 45°C with a Vishay Curve 1 thermistor choose:

$$R_{NOM} = \frac{3.266 - 0.4368}{2.714} \cdot 100k = 104.2k$$

the nearest 1% value is 105k.

$$R1 = 0.536 \cdot 105k - 0.4368 \cdot 100k = 12.6k$$

the nearest 1% value is 12.7k. The final solution is shown in Figure 4 and results in an upper trip point of 45°C and a lower trip point of 0°C.

### USB and Wall Adapter Power

Although the battery charger is designed to draw power from a USB port to charge Li-Ion batteries, a wall adapter can also be used. Figure 5 shows an example of how to combine wall adapter and USB power inputs. A P-channel MOSFET, MP1, is used to prevent back conduction into the USB port when a wall adapter is present and Schottky diode, D1, is used to prevent USB power loss through the 1k pull-down resistor.

Typically, a wall adapter can supply significantly more current than the 500mA-limited USB port. Therefore, an N-channel MOSFET, MN1, and an extra program resistor are used to increase the maximum charge current to 950mA when the wall adapter is present.

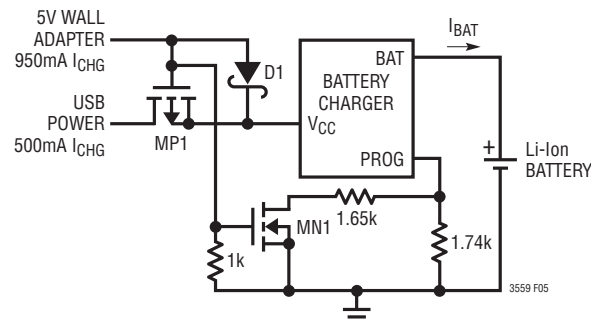

Figure 5. Combining Wall Adapter and USB Power

## APPLICATIONS INFORMATION

### Power Dissipation

The conditions that cause the LTC3559/LTC3559-1 to reduce charge current through thermal feedback can be approximated by considering the power dissipated in the IC. For high charge currents, the LTC3559/LTC3559-1 power dissipation is approximately:

$$P_D = (V_{CC} - V_{BAT}) \cdot I_{BAT}$$

where  $P_D$  is the power dissipated,  $V_{CC}$  is the input supply voltage,  $V_{BAT}$  is the battery voltage, and  $I_{BAT}$  is the charge current. It is not necessary to perform any worst-case power dissipation scenarios because the LTC3559/LTC3559-1 will automatically reduce the charge current to maintain the die temperature at approximately 105°C. However, the approximate ambient temperature at which the thermal feedback begins to protect the IC is:

$$T_A = 105^\circ\text{C} - P_D \theta_{JA}$$

$$T_A = 105^\circ\text{C} - (V_{CC} - V_{BAT}) \cdot I_{BAT} \cdot \theta_{JA}$$

Example: Consider an LTC3559/LTC3559-1 operating from a USB port providing 500mA to a 3.5V Li-Ion battery. The ambient temperature above which the LTC3559/LTC3559-1 will begin to reduce the 500mA charge current is approximately:

$$T_A = 105^\circ\text{C} - (5\text{V} - 3.5\text{V}) \cdot (500\text{mA}) \cdot 68^\circ\text{C}/\text{W}$$

$$T_A = 105^\circ\text{C} - 0.75\text{W} \cdot 68^\circ\text{C}/\text{W} = 105^\circ\text{C} - 51^\circ$$

$$T_A = 54^\circ\text{C}$$

The LTC3559/LTC3559-1 can be used above 70°C, but the charge current will be reduced from 500mA. The approximate current at a given ambient temperature can be calculated:

$$I_{BAT} = \frac{105^\circ\text{C} - T_A}{(V_{CC} - V_{BAT}) \cdot \theta_{JA}}$$

Using the previous example with an ambient temperature of 88°C, the charge current will be reduced to approximately:

$$I_{BAT} = \frac{105^\circ\text{C} - 88^\circ\text{C}}{(5\text{V} - 3.5\text{V}) \cdot 68^\circ\text{C}/\text{W}} = \frac{17^\circ\text{C}}{102^\circ\text{C}/\text{A}}$$

$$I_{BAT} = 167\text{mA}$$

Furthermore, the voltage at the PROG pin will change proportionally with the charge current as discussed in the Programming Charge Current section.

It is important to remember that LTC3559/LTC3559-1 applications do not need to be designed for worst-case thermal conditions since the IC will automatically reduce power dissipation when the junction temperature reaches approximately 105°C.

### Battery Charger Stability Considerations

The LTC3559/LTC3559-1 battery charger contains two control loops: the constant-voltage and constant-current loops. The constant-voltage loop is stable without any compensation when a battery is connected with low impedance leads. Excessive lead length, however, may add enough series inductance to require a bypass capacitor of at least 1.5μF from BAT to GND. Furthermore, a 4.7μF capacitor with a 0.2Ω to 1Ω series resistor from BAT to GND is required to keep ripple voltage low when the battery is disconnected.

High value capacitors with very low ESR (especially ceramic) reduce the constant-voltage loop phase margin, possibly resulting in instability. Ceramic capacitors up to 22μF may be used in parallel with a battery, but larger ceramics should be decoupled with 0.2Ω to 1Ω of series resistance.

In constant-current mode, the PROG pin is in the feedback loop, not the battery. Because of the additional pole created by the PROG pin capacitance, capacitance on this pin must be kept to a minimum. With no additional capacitance on the PROG pin, the charger is stable with program resistor values as high as 25K. However, additional capacitance on this node reduces the maximum allowed program resistor. The pole frequency at the PROG pin should be kept above 100kHz. Therefore, if the PROG pin is loaded with a capacitance,  $C_{PROG}$ , the following equation should be used to calculate the maximum resistance value for  $R_{PROG}$ :

$$R_{PROG} \leq \frac{1}{2\pi \cdot 10^5 \cdot C_{PROG}}$$

## APPLICATIONS INFORMATION

Average, rather than instantaneous, battery current may be of interest to the user. For example, if a switching power supply operating in low-current mode is connected in parallel with the battery, the average current being pulled out of the BAT pin is typically of more interest than the instantaneous current pulses. In such a case, a simple RC filter can be used on the PROG pin to measure the average battery current as shown in Figure 6. A 10k resistor has been added between the PROG pin and the filter capacitor to ensure stability.

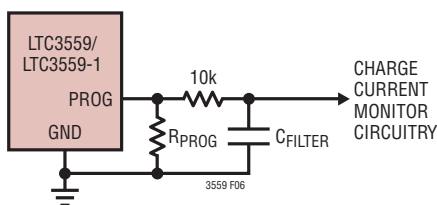

Figure 6. Isolated Capacitive Load on PROG Pin and Filtering

### USB Inrush Limiting

When a USB cable is plugged into a portable product, the inductance of the cable and the high-Q ceramic input capacitor form an L-C resonant circuit. If there is not much impedance in the cable, it is possible for the voltage at the input of the product to reach as high as twice the USB voltage (~10V) before it settles out. In fact, due to the high voltage coefficient of many ceramic capacitors (a nonlinearity), the voltage may even exceed twice the USB voltage. To prevent excessive voltage from damaging the LTC3559/LTC3559-1 during a hot insertion, the soft connect circuit in Figure 7 can be employed.

In the circuit of Figure 7, capacitor C1 holds MP1 off when the cable is first connected. Eventually C1 begins to charge up to the USB voltage applying increasing gate support to MP1. The long time constant of R1 and C1 prevents

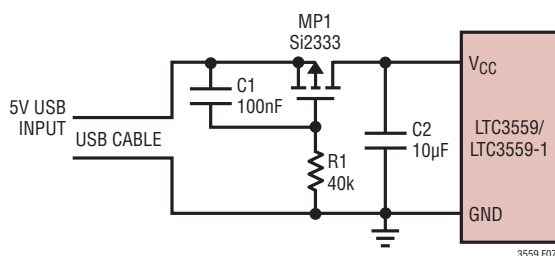

Figure 7. USB Soft Connect Circuit

the current from building up in the cable too fast thus dampening out any resonant overshoot.

### Buck Switching Regulator General Information

The LTC3559/LTC3559-1 contain two 2.25MHz constant-frequency current mode switching regulators that provide up to 400mA each. Both switchers can be programmed for a minimum output voltage of 0.8V and can be used to power a microcontroller core, microcontroller I/O, memory or other logic circuitry. Both regulators support 100% duty cycle operation (dropout mode) when the input voltage drops very close to the output voltage and are also capable of operating in Burst Mode operation for highest efficiencies at light loads (Burst Mode operation is pin selectable). The switching regulators also include soft-start to limit inrush current when powering on, short circuit current protection, and switch node slew limiting circuitry to reduce radiated EMI.

A single MODE pin sets both regulators in Burst Mode operation or pulse skip operating mode while each regulator is enabled individually through their respective enable pins EN1 and EN2. The buck regulators input supply (PV<sub>IN</sub>) should be connected to the battery pin (BAT). This allows the undervoltage lockout circuit on the BAT pin to disable the buck regulators when the BAT voltage drops below 2.45V. Do not drive the buck switching regulators from a voltage other than BAT. A 2.2µF decoupling capacitor from the PV<sub>IN</sub> pin to GND is recommended.

### Buck Switching Regulator Output Voltage Programming

Both switching regulators can be programmed for output voltages greater than 0.8V. The output voltage for each buck switching regulator is programmed using a resistor divider from the switching regulator output connected to the feedback pins (FB1 and FB2) such that:

$$V_{OUT} = 0.8(1 + R1/R2)$$

Typical values for R1 are in the range of 40k to 1M. The capacitor C<sub>FB</sub> cancels the pole created by feedback resistors and the input capacitance of the FB pin and also helps to improve transient response for output voltages much greater than 0.8V. A variety of capacitor sizes can be used for C<sub>FB</sub> but a value of 10pF is recommended for

3559fb

## APPLICATIONS INFORMATION

most applications. Experimentation with capacitor sizes between 2pF and 22pF may yield improved transient response if so desired by the user.

### Buck Switching Regulator Operating Modes

The step-down switching regulators include two possible operating modes to meet the noise/power needs of a variety of applications.

In pulse skip mode, an internal latch is set at the start of every cycle, which turns on the main P-channel MOSFET switch. During each cycle, a current comparator compares the peak inductor current to the output of an error amplifier. The output of the current comparator resets the internal latch, which causes the main P-channel MOSFET switch to turn off and the N-channel MOSFET synchronous rectifier to turn on. The N-channel MOSFET synchronous rectifier turns off at the end of the 2.25MHz cycle or if the current through the N-channel MOSFET synchronous rectifier drops to zero. Using this method of operation, the error amplifier adjusts the peak inductor current to deliver the required output power. All necessary compensation is internal to the step-down switching regulator requiring only a single ceramic output capacitor for stability. At light loads in pulse skip mode, the inductor current may reach zero on each pulse which will turn off the N-channel MOSFET synchronous rectifier. In this case, the switch node (SW1 or SW2) goes high impedance and the switch node voltage will “ring”. This is discontinuous operation, and is normal behavior for a switching regulator. At very light loads in pulse skip mode, the step-down switching

regulators will automatically skip pulses as needed to maintain output regulation. At high duty cycle ( $V_{OUT} > PV_{IN}/2$ ) in pulse skip mode, it is possible for the inductor current to reverse causing the buck converter to switch continuously. Regulation and low noise operation are maintained but the input supply current will increase to a couple mA due to the continuous gate switching.

During Burst Mode operation, the step-down switching regulators automatically switch between fixed frequency PWM operation and hysteretic control as a function of the load current. At light loads the step-down switching regulators control the inductor current directly and use a hysteretic control loop to minimize both noise and switching losses. During Burst Mode operation, the output capacitor is charged to a voltage slightly higher than the regulation point. The step-down switching regulator then goes into sleep mode, during which the output capacitor provides the load current. In sleep mode, most of the switching regulator’s circuitry is powered down, helping conserve battery power. When the output voltage drops below a pre-determined value, the step-down switching regulator circuitry is powered on and another burst cycle begins. The sleep time decreases as the load current increases. Beyond a certain load current point (about 1/4 rated output load current) the step-down switching regulators will switch to a low noise constant frequency PWM mode of operation, much the same as pulse skip operation at high loads. For applications that can tolerate some output ripple at low output currents, Burst Mode operation provides better efficiency than pulse skip at light loads.

The step-down switching regulators allow mode transition on-the-fly, providing seamless transition between modes even under load. This allows the user to switch back and forth between modes to reduce output ripple or increase low current efficiency as needed. Burst Mode operation is set by driving the MODE pin high, while pulse skip mode is achieved by driving the MODE pin low.

### Buck Switching Regulator in Shutdown

The buck switching regulators are in shutdown when not enabled for operation. In shutdown, all circuitry in the buck switching regulator is disconnected from the regulator input supply, leaving only a few nanoamps of

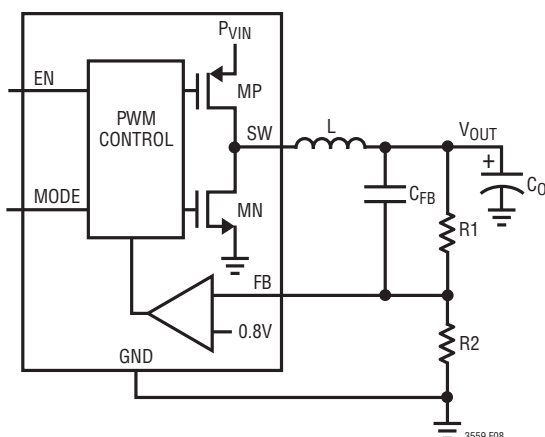

Figure 8. Buck Converter Application Circuit

## APPLICATIONS INFORMATION

leakage pulled to ground through a 10k resistor on the switch (SW1 or SW2) pin when in shutdown.

### Buck Switching Regulator Dropout Operation

It is possible for a step-down switching regulator's input voltage to approach its programmed output voltage (e.g., a battery voltage of 3.4V with a programmed output voltage of 3.3V). When this happens, the PMOS switch duty cycle increases until it is turned on continuously at 100%. In this dropout condition, the respective output voltage equals the regulator's input voltage minus the voltage drops across the internal P-channel MOSFET and the inductor.

### Buck Switching Regulator Soft-Start Operation

Soft-start is accomplished by gradually increasing the peak inductor current for each switching regulator over a 500 $\mu$ s period. This allows each output to rise slowly, helping minimize the battery in-rush current required to charge up the regulator's output capacitor. A soft-start cycle occurs whenever a switcher first turns on, or after a fault condition has occurred (thermal shutdown or UVLO). A soft-start cycle is not triggered by changing operating modes using the MODE pin. This allows seamless output operation when transitioning between operating modes.

### Buck Switching Regulator Switching Slew Rate Control

The buck switching regulators contain circuitry to limit the slew rate of the switch node (SW1 and SW2). This circuitry is designed to transition the switch node over a period of a couple of nanoseconds, significantly reducing radiated EMI and conducted supply noise while maintaining high efficiency.

### Buck Switching Regulator Low Supply Operation

An undervoltage lockout (UVLO) circuit on  $PV_{IN}$  shuts down the step-down switching regulators when BAT drops below 2.45V. This UVLO prevents the step-down switching regulators from operating at low supply voltages where loss of regulation or other undesirable operation may occur.

### Buck Switching Regulator Inductor Selection

The buck regulators are designed to work with inductors in the range of 2.2 $\mu$ H to 10 $\mu$ H, but for most applications a 4.7 $\mu$ H inductor is suggested. Larger value inductors reduce ripple current which improves output ripple voltage. Lower value inductors result in higher ripple current which improves transient response time. To maximize efficiency, choose an inductor with a low DC resistance. For a 1.2V output efficiency is reduced about 2% for every 100m $\Omega$  series resistance at 400mA load current, and about 2% for every 300m $\Omega$  series resistance at 100mA load current. Choose an inductor with a DC current rating at least 1.5 times larger than the maximum load current to ensure that the inductor does not saturate during normal operation. If output short circuit is a possible condition the inductor should be rated to handle the maximum peak current specified for the buck regulators.

Different core materials and shapes will change the size/current and price/current relationship of an inductor. Toroid or shielded pot cores in ferrite or permalloy materials are small and don't radiate much energy, but generally cost more than powdered iron core inductors with similar electrical characteristics. Inductors that are very thin or have a very small volume typically have much higher DCR losses, and will not give the best efficiency. The choice of which style inductor to use often depends more on the price vs size, performance, and any radiated EMI requirements than on what the buck regulator requires to operate.

The inductor value also has an effect on Burst Mode operation. Lower inductor values will cause Burst Mode switching frequency to increase.

Table 2 shows several inductors that work well with the LTC3559/LTC3559-1. These inductors offer a good compromise in current rating, DCR and physical size. Consult each manufacturer for detailed information on their entire selection of inductors.

## APPLICATIONS INFORMATION

**Table 2 Recommended Inductors**

INDUCTOR TYPE	L (μH)	MAX I <sub>DC</sub> (A)	MAX DCR(Ω)	SIZE IN MM (L × W × H)	MANUFACTURER	
DB318C	4.7	1.07	0.1	3.8 × 3.8 × 1.8	Toko www.toko.com	
	3.3	1.20	0.07	3.8 × 3.8 × 1.8		
D312C	4.7	0.79	0.24	3.6 × 3.6 × 1.2		
	3.3	0.90	0.20	3.6 × 3.6 × 1.2		
DE2812C	4.7	1.15	0.13*	3.0 × 2.8 × 1.2		
	3.3	1.37	0.105*	3.0 × 2.8 × 1.2		
CDRH3D16	4.7	0.9	0.11	4 × 4 × 1.8	Sumida www.sumida.com	
CDRH2D11	3.3	1.1	0.085	4 × 4 × 1.8		
	4.7	0.5	0.17	3.2 × 3.2 × 1.2		
3.3	0.6	0.123	3.2 × 3.2 × 1.2			
CLS4D09	4.7	0.75	0.19	4.9 × 4.9 × 1		
SD3118	4.7	1.3	0.162	3.1 × 3.1 × 1.8	Cooper www.cooperet.com	
	3.3	1.59	0.113	3.1 × 3.1 × 1.8		
SD3112	4.7	0.8	0.246	3.1 × 3.1 × 1.2		
	3.3	0.97	0.165	3.1 × 3.1 × 1.2		
SD12	4.7	1.29	0.117*	5.2 × 5.2 × 1.2		
	3.3	1.42	0.104*	5.2 × 5.2 × 1.2		
SD10	4.7	1.08	0.153*	5.2 × 5.2 × 1.0		
	3.3	1.31	0.108*	5.2 × 5.2 × 1.0		
LPS3015	4.7	1.1	0.2	3.0 × 3.0 × 1.5		Coilcraft www.coilcraft.com
	3.3	1.3	0.13	3.0 × 3.0 × 1.5		

\*Typical DCR

### Buck Switching Regulator Input/Output Capacitor Selection

Low ESR (equivalent series resistance) ceramic capacitors should be used at both switching regulator outputs as well as the switching regulator input supply. Only X5R or X7R ceramic capacitors should be used because they retain their capacitance over wider voltage and temperature ranges than other ceramic types. A 10μF output capacitor is sufficient for most applications. For good transient response and stability the output capacitor should retain at least 4μF of capacitance over operating temperature and bias voltage. The switching regulator input supply should be bypassed with a 2.2μF capacitor. Consult manufacturer for detailed information on their selection and specifications of ceramic capacitors. Many manufacturers now offer very thin (< 1mm tall) ceramic capacitors ideal for use in height-restricted designs. Table 3 shows a list of several ceramic capacitor manufacturers.

**Table 3: Recommended Ceramic Capacitor Manufacturers**

AVX	(803) 448-9411	www.avxcorp.com
Murata	(714) 852-2001	www.murata.com
Taiyo Yuden	(408) 537-4150	www.t-yuden.com
TDK	(888) 835-6646	www.tdk.com

### PCB Layout Considerations

As with all DC/DC regulators, careful attention must be paid while laying out a printed circuit board (PCB) and to component placement. The inductors, input PV<sub>IN</sub> capacitor and output capacitors must all be placed as close to the LTC3559/LTC3559-1 as possible and on the same side as the LTC3559/LTC3559-1. All connections must be made on that same layer. Place a local unbroken ground plane below these components that is tied to the Exposed Pad (Pin 17) of the LTC3559/LTC3559-1. The Exposed Pad must also be soldered to system ground for proper operation.

## TYPICAL APPLICATIONS

The Output Voltage of a Buck Regulator Is Programmed for 3.3V. When BAT Voltage Approaches 3.3V, the Regulator Operates in Dropout and the Output Voltage Will Be  $BAT - (I_{LOAD} \cdot 0.6)$ . An LED at CHRG Gives a Visual Indication of the Battery Charger State. A 3-Resistor Bias Network for NTC Sets Hot and Cold Trip Points at Approximately 55°C and 0°C

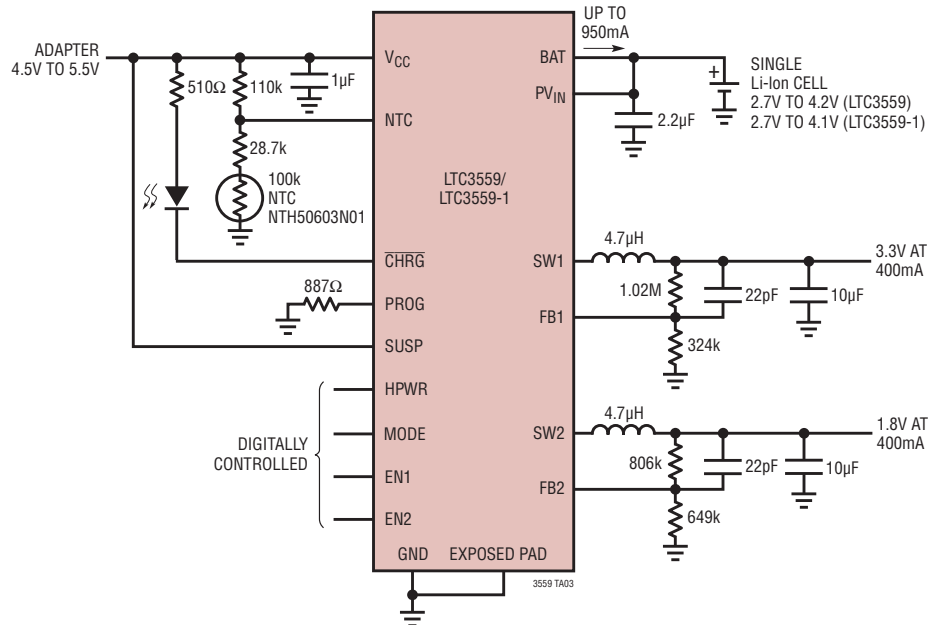

Buck Regulator Efficiency vs  $I_{LOAD}$

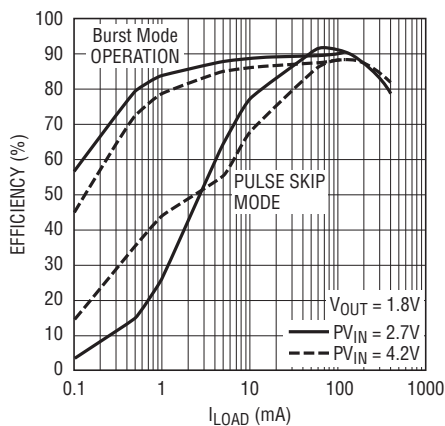

3559 TA02b

Buck Regulator Efficiency vs  $I_{LOAD}$

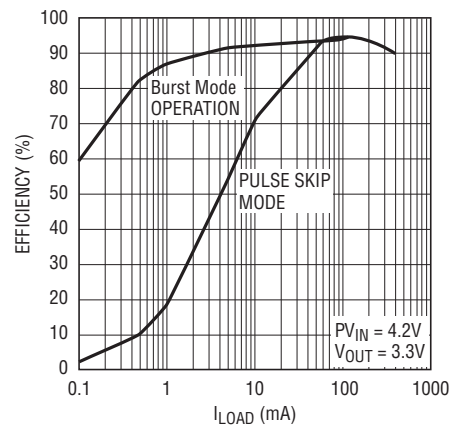

3559 TA02c

## TYPICAL APPLICATIONS

The Battery Can be Charged with Up to 950mA of Charge Current. Buck Regulator 2 Is Enabled Only After  $V_{OUT1}$  Is Up to Approximately 0.7V. This Provides a Sequencing Function Which May Be Desirable in Applications Where a Microprocessor Needs to Be Powered Up Before Peripherals. CHRG Interfaces to a Microprocessor Which Decodes the Battery Charger State

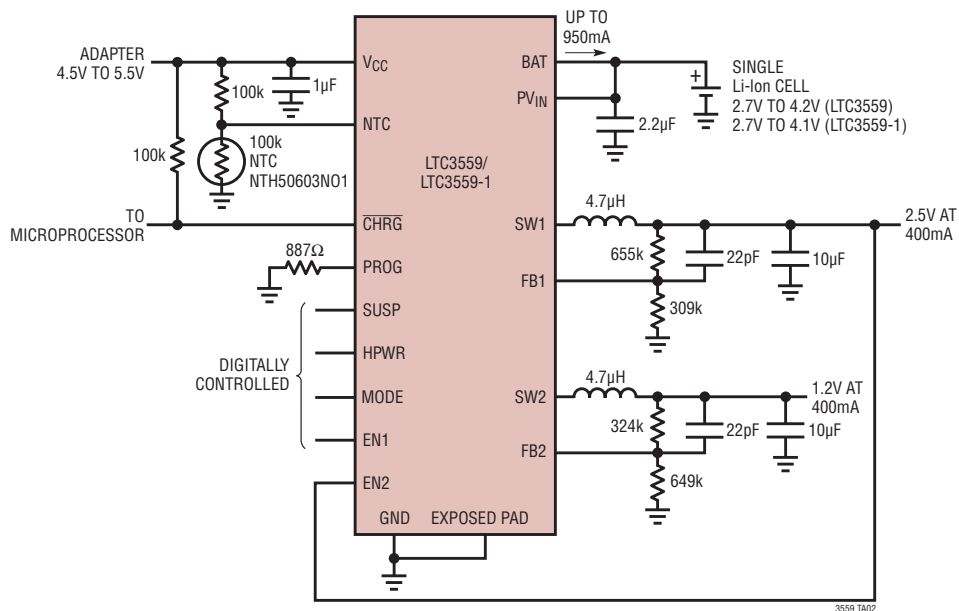

## PACKAGE DESCRIPTION

**UD Package**  
**16-Lead Plastic QFN (3mm × 3mm)**  
 (Reference LTC DWG # 05-08-1691)

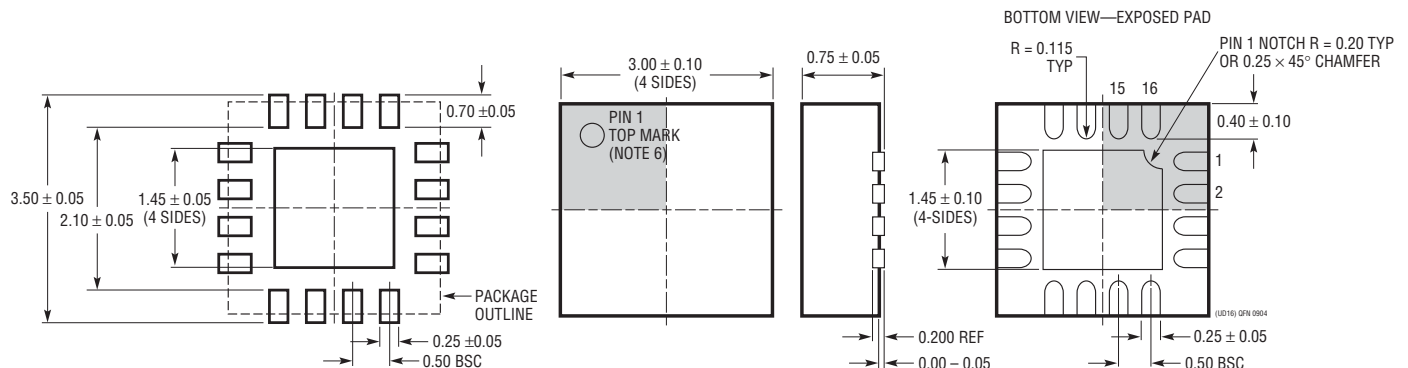

RECOMMENDED SOLDER PAD PITCH AND DIMENSIONS

NOTE:

1. DRAWING CONFORMS TO JEDEC PACKAGE OUTLINE MO-220 VARIATION (WEED-2)
2. DRAWING NOT TO SCALE
3. ALL DIMENSIONS ARE IN MILLIMETERS
4. DIMENSIONS OF EXPOSED PAD ON BOTTOM OF PACKAGE DO NOT INCLUDE MOLD FLASH. MOLD FLASH, IF PRESENT, SHALL NOT EXCEED 0.15mm ON ANY SIDE
5. EXPOSED PAD SHALL BE SOLDER PLATED
6. SHADED AREA IS ONLY A REFERENCE FOR PIN 1 LOCATION ON THE TOP AND BOTTOM OF PACKAGE



## RELATED PARTS

PART NUMBER	DESCRIPTION	COMMENTS
LTC3550	Dual Input USB/AC Adapter Li-Ion Battery Charger with Adjustable Output 600mA Buck Converter	Synchronous Buck Converter, Efficiency: 93%, Adjustable Output at 600mA, Charge Current: 950mA Programmable, USB Compatible, Automatic Input Power Detection and Selection
LTC3552	Standalone Linear Li-Ion Battery Charger with Adjustable Output Dual Synchronous Buck Converter	Synchronous Buck Converter, Efficiency: >90%, Adjustable Outputs at 800mA and 400mA, Charge Current Programmable Up to 950mA, USB Compatible, 5mm × 3mm DFN16 Package
LTC3552-1	Standalone Linear Li-Ion Battery Charger with Dual Synchronous Buck Converter	Synchronous Buck Converter, Efficiency: >90%, Outputs 1.8V at 800mA and 1.575 at 400mA, Charge Current Programmable Up to 950mA, USB Compatible
LTC3455	Dual DC/DC Converter with USB Power Manager and Li-Ion Battery Charger	Seamless Transition Between Input Power Sources: Li-Ion Battery, USB and 5V Wall Adapter, Two High Efficiency DC/DC Converters: Up to 96%, Full-Featured Li-Ion Battery Charger with Accurate USB Current Limiting (500mA/100mA) Pin-Selectable Burst Mode Operation, Hot Swap™ Output for SDIO and Memory Cards, 4mm × 4mm QFN24 Package
LTC3456	2-Cell, Multi-Output DC/DC Converter with USB Power Manager	Seamless Transition Between 2-Cell Battery, USB and AC Wall Adapter Input Power Sources, Main Output: Fixed 3.3V Output, Core Output: Adjustable From 0.8V to $V_{BATT(MIN)}$ , Hot Swap Output for Memory Cards, Power Supply Sequencing: Main and Hot Swap Accurate USB Current Limiting, High Frequency Operation: 1MHz, High Efficiency: Up to 92%, 4mm × 4mm QFN24 Package
LTC4080	500mA Standalone Charger with 300mA Synchronous Buck	Charges Single-Cell Li-Ion Batteries, Timer Termination +C/10, Thermal Regulation, Buck Output: 0.8V to $V_{BAT}$ , Buck Input $V_{IN}$ : 2.7V to 5.5V, 3mm × 3mm DFN10 Package

Hot Swap is a trademark of Linear Technology Corporation.

## Looking for pricing, stock, or lifecycle information?

Click below to explore more details on WIN SOURCE:

-  [View LTC3559EUD#PBF on WIN SOURCE](#)
-  [Linear Technology](#) Information

## Optimize Your Supply Chain with WIN SOURCE Solutions

-  Global Sourcing Solution
-  Obsolete Management
-  Cost Control Management
-  Shortage Management
-  Alternative Solution
-  Excess Inventory Management