



**THE DATASHEET OF  
LTC3456EUF#PBF**



## 2-Cell, Multi-Output DC/DC Converter with USB Power Manager

### FEATURES

- Seamless Transition Between 2-Cell Battery, USB and AC Wall Adapter Input Power Sources
- Main Output: Fixed 3.3V Output
- Core Output: Adjustable from 0.8V to  $V_{BATT(MIN)}$
- Hot Swap™ Output for Memory Cards
- All Outputs Discharged to Ground During Shutdown
- Power Supply Sequencing: Main and Hot Swap Outputs Come Up After Core Output
- Accurate USB Current Limiting
- High Frequency Operation: 1MHz
- High Efficiency: Up to 92%
- Small (4mm × 4mm × 0.75mm) 24-Pin QFN Package

### APPLICATIONS

- GPS Portable Navigators
- MP3 Players
- Digital Cameras
- Handheld Computers

### DESCRIPTION

The LTC<sup>®</sup>3456 is a complete power management system IC optimized for a variety of portable applications. The device generates two separate power rails: a 3.3V (fixed) Main supply and a 1.8V (adjustable) Core supply. In addition, the LTC3456 contains a USB power manager, a Hot Swap output, a low-battery indicator and an always-alive  $V_{MAX}$  output. The LTC3456 takes power from one of three sources: a Wall adapter, a USB port or a 2-cell Alkaline/NiCd/NiMH battery, in that order of priority. Current drawn from the USB port is accurately limited to 100mA or 500mA based on the state of the USBHP pin.

The Main and Core switchers are all high efficiency, 1MHz fixed frequency PWM converters. Availability in a small (4mm × 4mm × 0.75mm) 24-pin QFN package makes the LTC3456 ideal for space-sensitive portable devices.

LT, LTC and LT are registered trademarks of Linear Technology Corporation. Hot Swap is a trademark of Linear Technology Corporation. All other trademarks are the property of their respective owners. Protected by U.S. Patents including 5481178, 6580258, 6304066.

### TYPICAL APPLICATION

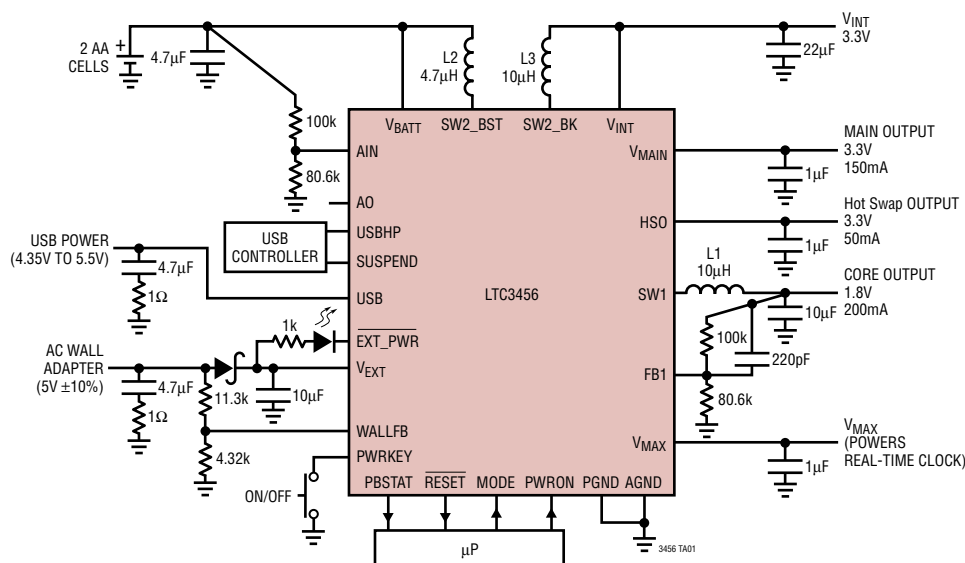

**Efficiency and Power Loss vs Load Current (Battery Powered)**

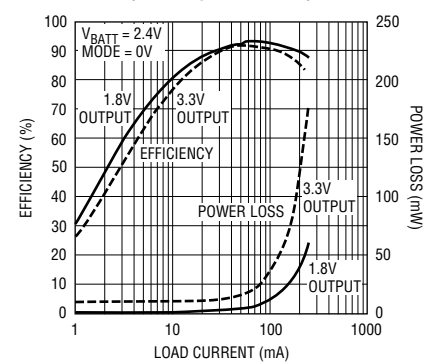

## ABSOLUTE MAXIMUM RATINGS

(Note 1)

$V_{BATT}$ , $V_{MAX}$ Voltages .....	-0.3V to 6V
$V_{INT}$ , $V_{MAIN}$ , $V_{EXT}$ , HSO Voltages .....	-0.3V to 6V
SW1, SW2_BK, SW2_BST Voltages .....	-0.3V to 6V
USB, USBHP, SUSPEND Voltages .....	-0.3V to 6V
PWRKEY, PBSTAT, PWRON Voltages .....	-0.3V to 6V
MODE, AO, EXT_PWR, RESET Voltages .....	-0.3V to 6V
FB1, AIN, WALLFB Voltages .....	-0.3V to 2V
Junction Temperature .....	125°C
Operating Temperature Range (Note 2) ..	-40°C to 85°C
Storage Temperature Range .....	-65°C to 125°C

## PACKAGE/ORDER INFORMATION

<p>TOP VIEW</p> <p>UF PACKAGE 24-LEAD (4mm × 4mm) PLASTIC QFN <math>T_{JMAX} = 125^{\circ}\text{C}</math>, <math>\theta_{JA} = 37^{\circ}\text{C/W}</math>, <math>\theta_{JC} = 2^{\circ}\text{C/W}</math> EXPOSED PAD (PIN 25) IS PGND MUST BE SOLDERED TO PCB</p>	ORDER PART NUMBER
	LTC3456EUF
	UF PART MARKING
	3456
<b>Order Options</b> Tape and Reel: Add #TR Lead Free: Add #PBF Lead Free Tape and Reel: Add #TRPBF Lead Free Part Marking: <a href="http://www.linear.com/leadfree/">http://www.linear.com/leadfree/</a>	

Consult LTC Marketing for parts specified with wider operating temperature ranges.

## ELECTRICAL CHARACTERISTICS

The ● denotes specifications which apply over the full operating temperature range, otherwise specifications are at  $T_A = 25^{\circ}\text{C}$ .  
 $V_{BATT} = 2.4\text{V}$ ,  $V_{INT} = 3.3\text{V}$ ,  $V_{PWRON} = 2\text{V}$ , PWRKEY is open,  $V_{USB} = 0\text{V}$ ,  $V_{WALLFB} = 0\text{V}$ , unless otherwise specified.

PARAMETER	CONDITIONS	MIN	TYP	MAX	UNITS
Battery Voltage Range		1.8		3.2	V
Quiescent Current (Battery Powered)	(Note 3)				
Burst Mode® Operation	$V_{MODE} = 2\text{V}$ , $V_{FB1} = 1\text{V}$ , $V_{INT} = 3.4\text{V}$		180	250	$\mu\text{A}$
PWM Operation	$V_{MODE} = 0\text{V}$ , $V_{FB1} = 1\text{V}$ , $V_{INT} = 3.4\text{V}$		380	450	$\mu\text{A}$
Shutdown	$V_{PWRON} = 0\text{V}$ , $V_{INT} = 0\text{V}$		0.1	1	$\mu\text{A}$
$V_{BATT}$ Pin Current (Wall Powered)	$V_{WALLFB} = 1.5\text{V}$ , $V_{EXT} = 5\text{V}$ (Note 4)		1	2	$\mu\text{A}$
$V_{BATT}$ Pin Current (USB Powered)	$V_{USB} = 5\text{V}$ , $V_{EXT} = 5\text{V}$ (Note 4)		1	2	$\mu\text{A}$
Switching Frequency					
Battery Powered	$V_{BATT} = 2.4\text{V}$	0.8	1	1.2	MHz
USB or Wall Powered	$V_{EXT} = 5\text{V}$ , $V_{WALLFB} = 1.5\text{V}$	0.8	1	1.2	MHz
<b>Main Output</b>					
$V_{INT}$ Voltage Regulation		● 3.22	3.3	3.38	V
$V_{INT}$ Voltage Line Regulation	$V_{BATT} = 1.8\text{V}$ to $3.2\text{V}$	●	0.1	0.5	%/V
Max Duty Cycle		● 80	87		%
Switch Leakage (Battery Powered)	$V_{PWRON} = 0\text{V}$				
SW2_BST PMOS Switch	$V_{SW2\_BST} = 0\text{V}$		0.1	1	$\mu\text{A}$
SW2_BST NMOS Switch	$V_{SW2\_BST} = 3.3\text{V}$		0.1	1	$\mu\text{A}$
Switch On-Resistance (Battery Powered)					
SW2_BST PMOS Switch	$I_{SW2\_BST} = 150\text{mA}$		0.8		$\Omega$
SW2_BST NMOS Switch	$I_{SW2\_BST} = -150\text{mA}$		0.5		$\Omega$

Burst Mode is a registered trademark of Linear Technology

## ELECTRICAL CHARACTERISTICS

The ● denotes specifications which apply over the full operating temperature range, otherwise specifications are at  $T_A = 25^\circ\text{C}$ .  
 $V_{\text{BATT}} = 2.4\text{V}$ ,  $V_{\text{INT}} = 3.3\text{V}$ ,  $V_{\text{PWRON}} = 2\text{V}$ , PWRKEY is open,  $V_{\text{USB}} = 0\text{V}$ ,  $V_{\text{WALLFB}} = 0\text{V}$ , unless otherwise specified.

PARAMETER	CONDITIONS	MIN	TYP	MAX	UNITS	
Switch Leakage (USB/Wall Powered) SW2_BK PMOS Switch SW2_BK NMOS Switch	$V_{\text{EXT}} = 5\text{V}$ , $V_{\text{WALLFB}} = 1.5\text{V}$ , $V_{\text{PWRON}} = 0\text{V}$ $V_{\text{SW2\_BK}} = 0\text{V}$ $V_{\text{SW2\_BK}} = 5\text{V}$		0.1 0.1	1 1	$\mu\text{A}$ $\mu\text{A}$	
Switch On-Resistance (USB/Wall Powered) SW2_BK PMOS Switch SW2_BK NMOS Switch	$V_{\text{EXT}} = 5\text{V}$ , $V_{\text{WALLFB}} = 1.5\text{V}$ $I_{\text{SW2\_BK}} = 150\text{mA}$ $I_{\text{SW2\_BK}} = -150\text{mA}$		0.9 0.4		$\Omega$ $\Omega$	
Switch Current Limit Battery Powered (SW2_BST NMOS Current) Wall/USB Powered (SW2_BK PMOS Current)	$V_{\text{BATT}} = 2.4\text{V}$ $V_{\text{EXT}} = 5\text{V}$ , $V_{\text{WALLFB}} = 1.5\text{V}$	700 400	900 500		$\text{mA}$ $\text{mA}$	
$V_{\text{MAIN}}$ PMOS Switch On-Resistance	Measured Between $V_{\text{INT}}$ and $V_{\text{MAIN}}$ Pins		0.4		$\Omega$	
$V_{\text{MAIN}}$ Turn-On Delay Battery Powered USB or Wall Powered	After FB1 and $V_{\text{INT}}$ in Regulation $V_{\text{BATT}} = 2.4\text{V}$ $V_{\text{EXT}} = 5\text{V}$ , $V_{\text{WALLFB}} = 1.5\text{V}$	● ●	0.8 1.5	2 2	$\text{ms}$ $\text{ms}$	
<b>Hot Swap Output</b>						
HSO PMOS Switch On-Resistance	Measured Between $V_{\text{INT}}$ and HSO Pins		0.8		$\Omega$	
HSO PMOS Switch Current Limit	$V_{\text{INT}} = 3.3\text{V}$ , $V_{\text{HSO}} = 2.5\text{V}$	90	120		$\text{mA}$	
HSO Turn-On Delay Battery Powered USB or Wall Powered	After FB1 and $V_{\text{INT}}$ in Regulation $V_{\text{BATT}} = 2.4\text{V}$ $V_{\text{EXT}} = 5\text{V}$ , $V_{\text{WALLFB}} = 1.5\text{V}$	● ●	0.5 0.5	1 1	$\text{ms}$ $\text{ms}$	
<b><math>V_{\text{MAX}}</math> Output</b>						
$V_{\text{MAX}}$ Output Voltage Shutdown Battery Powered USB/Wall Powered	$V_{\text{MAX}}$ Output Unloaded $V_{\text{PWRON}} = 0\text{V}$ $V_{\text{PWRON}} = 2\text{V}$ , $V_{\text{BATT}} = 2.4\text{V}$ $V_{\text{PWRON}} = 2\text{V}$ , $V_{\text{EXT}} = 5\text{V}$ , $V_{\text{WALLFB}} = 1.5\text{V}$		$V_{\text{BATT}}$ 3.3 5		$\text{V}$ $\text{V}$ $\text{V}$	
Maximum $V_{\text{MAX}}$ Output Current	$V_{\text{MAX}}$ Output < 12.5% Below Nominal Value	●	1		$\text{mA}$	
<b>Core Output</b>						
FB1 Voltage		●	0.784	0.800	0.816	$\text{V}$
FB1 Voltage Line Regulation	$V_{\text{BATT}} = 1.8\text{V}$ to $3.2\text{V}$	●		0.1	0.5	$\%/V$
FB1 Pin Input Bias Current	$V_{\text{FB1}} = 0.8\text{V}$	●		$\pm 2$	$\pm 20$	$\text{nA}$
Duty Cycle Range	Buck Switchers	●	0		100	$\%$
SW1 PMOS Switch Current Limit Battery Powered Wall/USB Powered	$V_{\text{BATT}} = 2.4\text{V}$ $V_{\text{EXT}} = 5\text{V}$		400 350	550 450		$\text{mA}$ $\text{mA}$
SW1 Leakage Current	$V_{\text{SW1}} = 0\text{V}$ , $V_{\text{EXT}} = 5\text{V}$ or $V_{\text{BATT}} = 5\text{V}$			0.1	1	$\mu\text{A}$
SW1 PMOS Switch On-Resistance Battery Powered Wall/USB Powered	$I_{\text{SW1}} = 150\text{mA}$ $V_{\text{BATT}} = 2.4\text{V}$ $V_{\text{EXT}} = 5\text{V}$ , $V_{\text{WALLFB}} = 1.5\text{V}$			0.5 0.5		$\Omega$ $\Omega$
SW1 NMOS Switch On-Resistance Battery Powered Wall/USB Powered	$I_{\text{SW1}} = -150\text{mA}$ $V_{\text{BATT}} = 2.4\text{V}$ $V_{\text{EXT}} = 5\text{V}$ , $V_{\text{WALLFB}} = 1.5\text{V}$			0.4 0.4		$\Omega$ $\Omega$

## ELECTRICAL CHARACTERISTICS

The ● denotes specifications which apply over the full operating temperature range, otherwise specifications are at  $T_A = 25^\circ\text{C}$ .  $V_{\text{BATT}} = 2.4\text{V}$ ,  $V_{\text{INT}} = 3.3\text{V}$ ,  $V_{\text{PWRON}} = 2\text{V}$ , PWRKEY is open,  $V_{\text{USB}} = 0\text{V}$ ,  $V_{\text{WALLFB}} = 0\text{V}$ , unless otherwise specified.

PARAMETER	CONDITIONS		MIN	TYP	MAX	UNITS
<b>USB</b>						
USB Turn-On Voltage Threshold	Rising Edge		3.9	4	4.1	V
USB Turn-On Voltage Hysteresis				75		mV
USB PMOS Switch On-Resistance	$V_{\text{USB}} = 5\text{V}$			0.5		$\Omega$
USB Current Limit	$V_{\text{USBHP}} = 2\text{V}$ (500mA Mode), $V_{\text{USB}} = 5\text{V}$ $V_{\text{USBHP}} = 0\text{V}$ (100mA Mode), $V_{\text{USB}} = 5\text{V}$	●		420 85	500 100	mA mA
SUSPEND Pin Threshold	$V_{\text{USB}} = 5\text{V}$		0.3	0.8	1.2	V
USBHP Pin Threshold	$V_{\text{USB}} = 5\text{V}$		0.3	0.8	1.2	V
SUSPEND Pin Pull-Down Current	$V_{\text{USB}} = 5\text{V}$ , $V_{\text{SUSPEND}} = 2\text{V}$			2.5		$\mu\text{A}$
USBHP Pin Pull-Down Current	$V_{\text{USB}} = 5\text{V}$ , $V_{\text{USBHP}} = 2\text{V}$			2.5		$\mu\text{A}$
USB Pin Bias Current (Suspend Mode)	$V_{\text{USB}} = 5\text{V}$ , $V_{\text{SUSPEND}} = 2\text{V}$			100	150	$\mu\text{A}$
<b>AC Adapter</b>						
WALLFB Pin Threshold	Rising Edge	●	1.2	1.25	1.3	V
WALLFB Pin Hysteresis				20		mV
WALLFB Pin Input Bias Current	$V_{\text{WALLFB}} = 1.25\text{V}$ , $V_{\text{EXT}} = 5\text{V}$	●		$\pm 2$	$\pm 20$	nA
$V_{\text{EXT}}$ UVLO Voltage	Rising Edge		3.9	4	4.1	V
$V_{\text{EXT}}$ UVLO Hysteresis				150		mV
EXT_PWR Pin Low Voltage	$V_{\text{USB}} > 4\text{V}$ and $V_{\text{SUSPEND}} = 0\text{V}$ or $V_{\text{WALLFB}} > 1.25\text{V}$ , $I_{\text{EXT\_PWR}} = 1\text{mA}$			0.25	0.5	V
<b>Gain Block</b>						
AIN Pin Reference Voltage			0.76	0.800	0.84	V
AIN Pin Input Bias Current	$V_{\text{AIN}} = 0.8\text{V}$	●		$\pm 2$	$\pm 20$	nA
AO Pin Low Voltage	$V_{\text{AIN}} = 0\text{V}$ , $I_{\text{AO}} = 1\text{mA}$			0.25	0.5	V
<b>Logic Inputs</b>						
PWRKEY Pin Input High Voltage			$0.7V_{\text{MAX}}$			V
PWRKEY Pin Input Low Voltage					$0.3V_{\text{MAX}}$	V
PWRKEY Pin Pull-Up Resistor to $V_{\text{MAX}}$				400		$\text{k}\Omega$
PBSTAT Pin Low Voltage	$V_{\text{PWRKEY}} = 0\text{V}$ , $I_{\text{PBSTAT}} = 100\mu\text{A}$			0.05	0.1	V
PWRON Pin Threshold			0.3	0.8	1.2	V
PWRON Pin Pull-Down Current	$V_{\text{PWRON}} = 2\text{V}$			1		$\mu\text{A}$
MODE Pin Threshold			0.3	0.8	1.2	V
MODE Pin Pull-Down Current	$V_{\text{MODE}} = 2\text{V}$			1		$\mu\text{A}$
RESET Pin Low Voltage	$I_{\text{RESET}} = 100\mu\text{A}$			0.05	0.1	V
RESET Pulse Duration	After $V_{\text{FB1}}$ and $V_{\text{INT}}$ in Regulation			262		ms

**Note 1:** Absolute Maximum Ratings are those values beyond which the life of the device may be impaired.

**Note 2:** The LTC3456 is guaranteed to meet performance specifications from  $0^\circ\text{C}$  to  $70^\circ\text{C}$ . Specifications over the  $-40^\circ\text{C}$  to  $85^\circ\text{C}$  operating temperature range are assured by design, characterization and correlation with statistical process controls.

**Note 3:** Quiescent current is pulled from the  $V_{\text{INT}}$  pin when neither USB nor wall power is present. Multiply this value by  $V_{\text{INT}}/V_{\text{BATT}}$  to get the equivalent input (battery) current.

**Note 4:** Quiescent current is pulled from the  $V_{\text{EXT}}$  pin when either USB or wall power is present.

**Note 5:** Specification is guaranteed by design and not 100% tested in production.

**TYPICAL PERFORMANCE CHARACTERISTICS**  $T_A = 25^\circ\text{C}$  unless otherwise specified.

**Core Converter Efficiency (Battery Powered)**

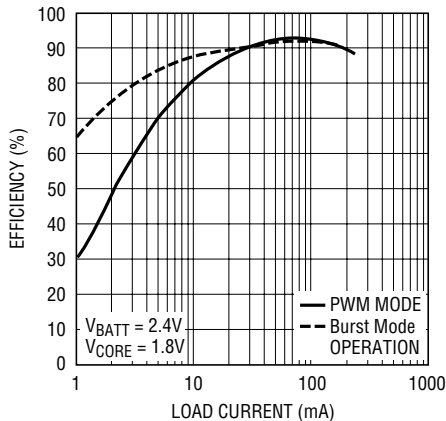

3456 G01

**Main Converter Efficiency (Battery Powered)**

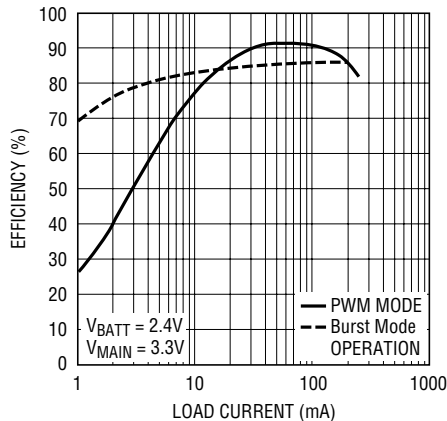

3456 G02

**Efficiency (USB Powered)**

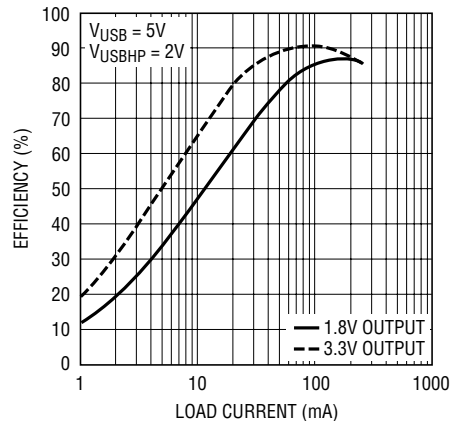

3456 G03

**Oscillator Frequency vs Battery Voltage**

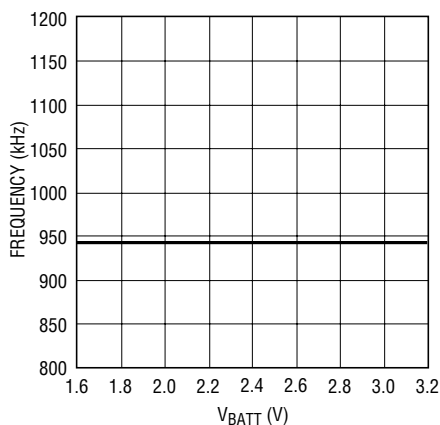

3456 G04

**Oscillator Frequency vs V\_EXT Voltage**

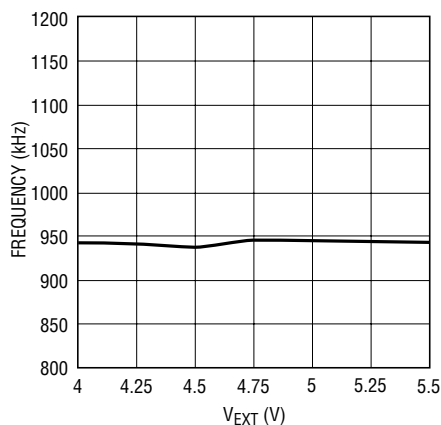

3456 G05

**Oscillator Frequency vs Temperature**

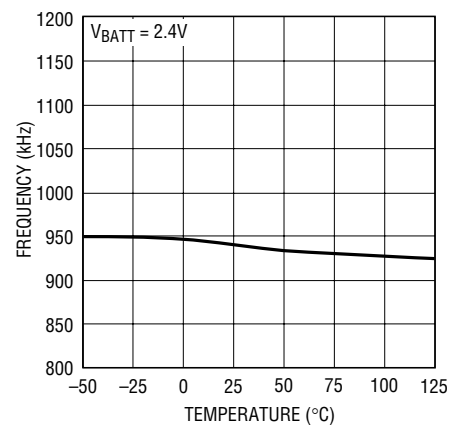

3456 G06

**No Load Battery Supply Current vs Battery Voltage**

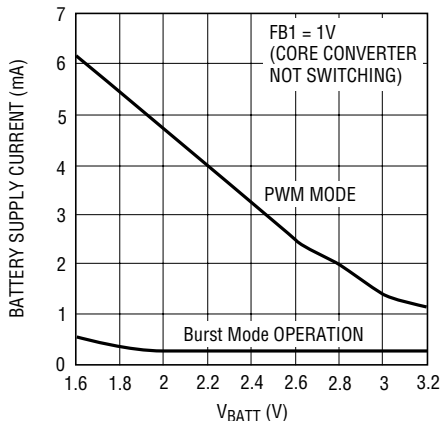

3456 G07

**No Load Battery Supply Current vs Temperature**

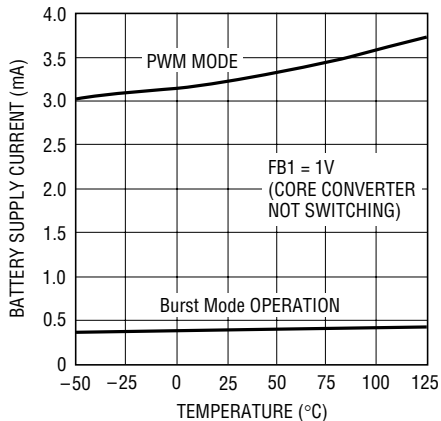

3456 G08

**Shutdown Current vs Temperature**

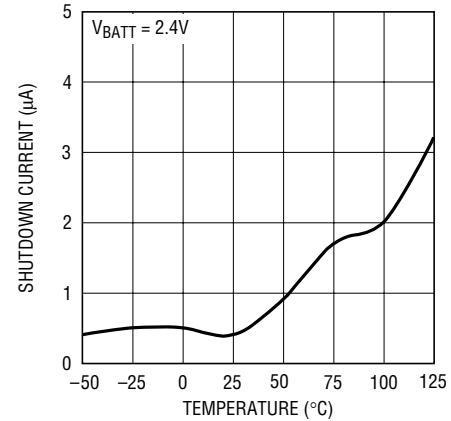

3456 G09

**TYPICAL PERFORMANCE CHARACTERISTICS**  $T_A = 25^\circ\text{C}$  unless otherwise specified.

**$V_{\text{BATT}}$  Pin Current when USB or Wall Powered**

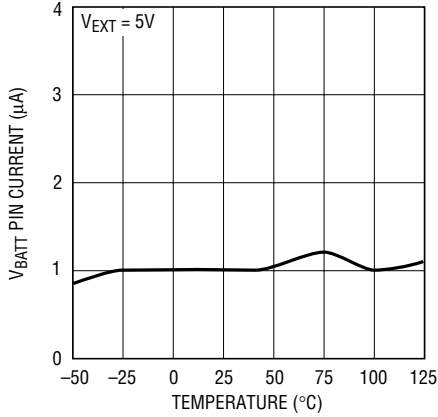

3456 G10

**No Load  $V_{\text{EXT}}$  Supply Current when USB or Wall Powered**

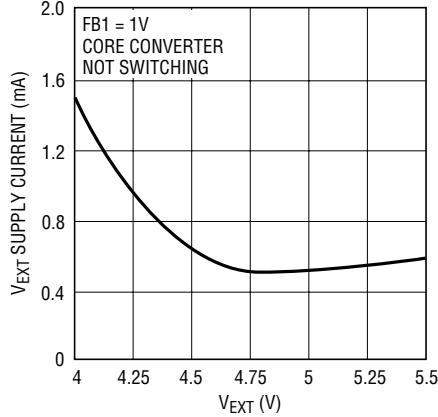

3456 G11

**SW1 Current Limit**

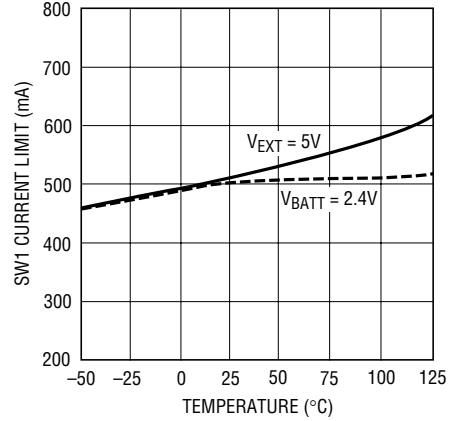

3456 G12

**SW2\_BST Current Limit**

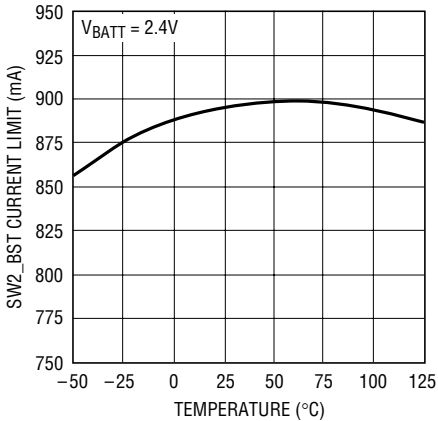

3456 G13

**SW2\_BK Current Limit**

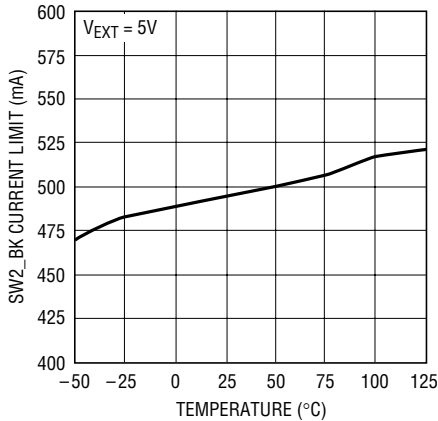

3456 G14

**Hot Swap (HSO) Current Limit**

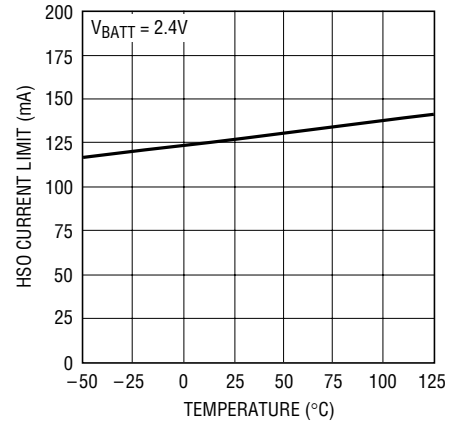

3456 G15

**$V_{\text{INT}}$  Load Current vs Start-Up Battery Voltage**

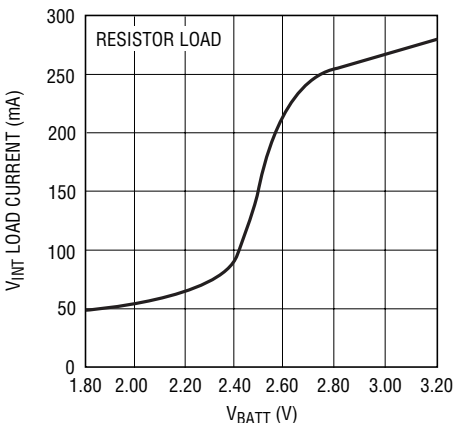

3456 G16

**Maximum  $V_{\text{MAIN}}$  Load Current Capability (Output 4% Below Regulation)**

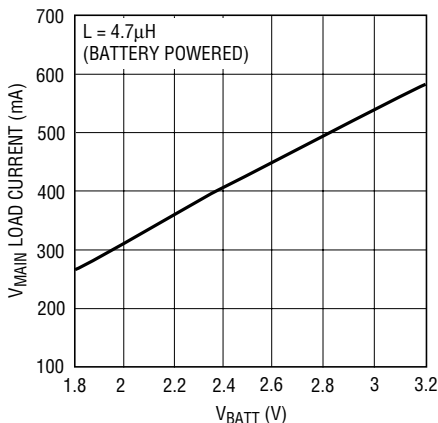

3456 G17

**Maximum  $V_{\text{CORE}}$  Load Current Capability (Output 4% Below Regulation)**

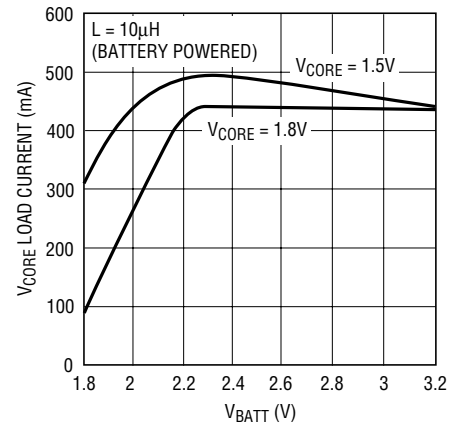

3456 G18

**TYPICAL PERFORMANCE CHARACTERISTICS**  $T_A = 25^\circ\text{C}$  unless otherwise specified.

**Maximum  $V_{\text{CORE}}$  Load Current Capability (Output 4% Below Regulation)**

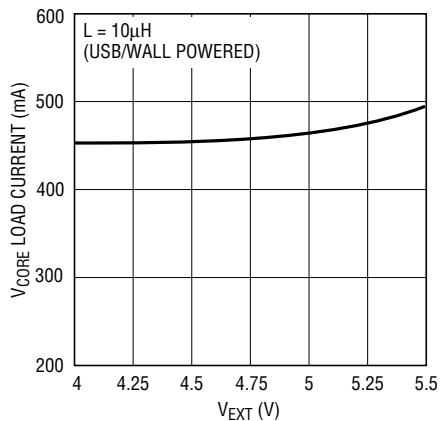

3456 G19

**Maximum  $V_{\text{MAIN}}$  Load Current Capability (Output 4% Below Regulation)**

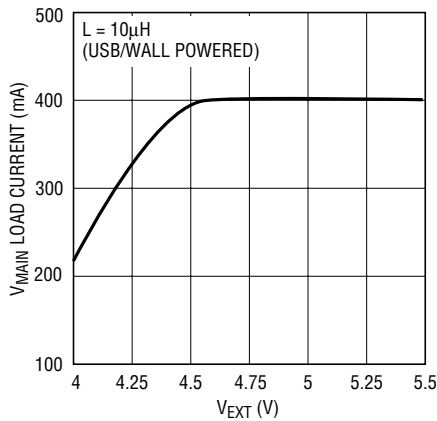

3456 G20

**USB Undervoltage Lockout**

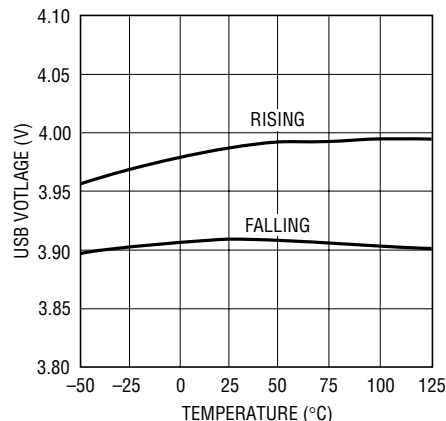

3456 G21

**USB Current Limit**

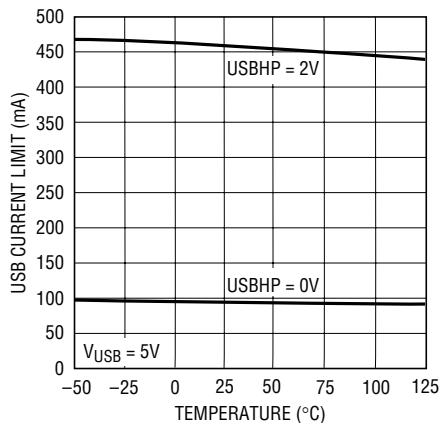

3456 G22

**$A_{\text{IN}}$  Pin Reference Voltage**

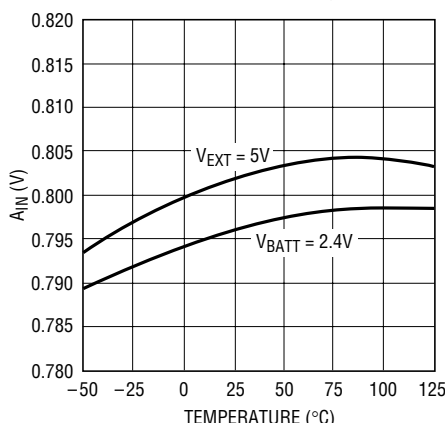

3456 G23

**WALLFB Trip Point**

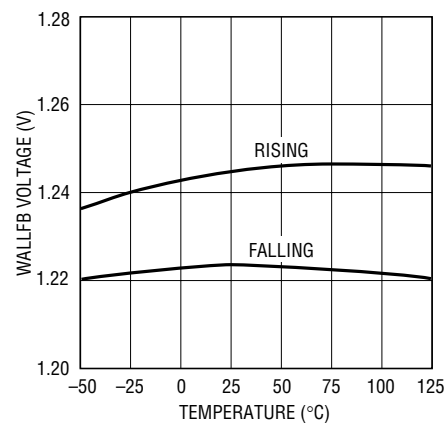

3456 G24

**$V_{\text{EXT}}$  Undervoltage Lockout**

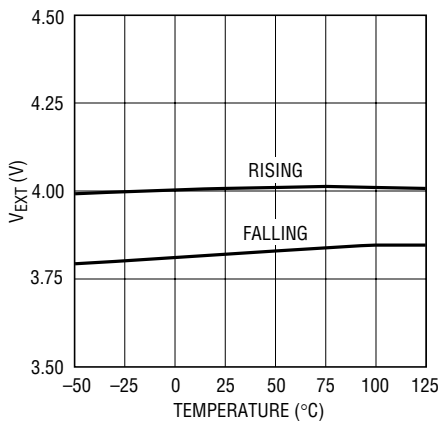

3456 G25

**$V_{\text{MAX}}$  Output Voltage (Battery Powered)**

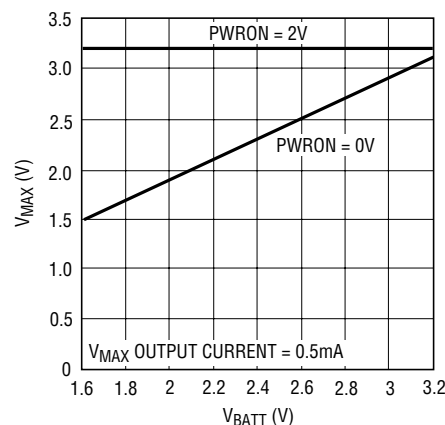

3456 G26

**$V_{\text{MAX}}$  Output Voltage (USB/Wall Powered)**

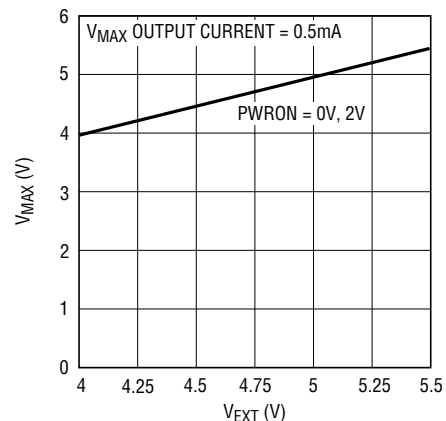

3456 G27

**TYPICAL PERFORMANCE CHARACTERISTICS**  $T_A = 25^\circ\text{C}$  unless otherwise specified.

**Switching Waveforms  
(Battery Powered)**

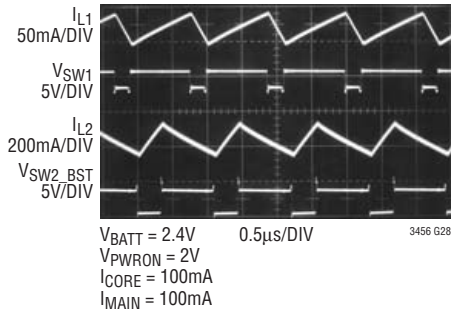

**Switching Waveforms  
(Wall/USB Powered)**

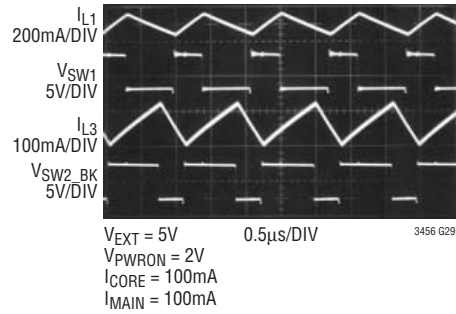

**USB ↔ Battery Switchover  
(Main Converter Transient Waveforms)**

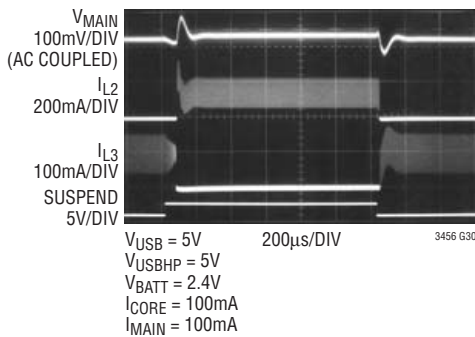

**USB ↔ Battery Switchover  
(Core Converter Transient Waveforms)**

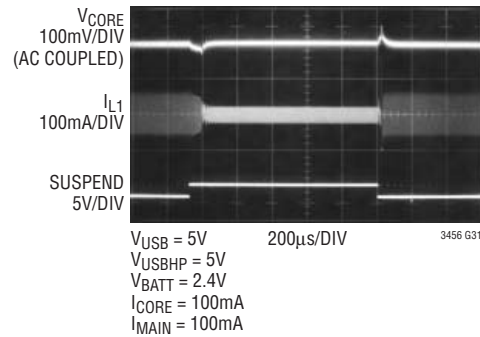

**Power Up/Power Down Sequencing  
(Battery Powered)**

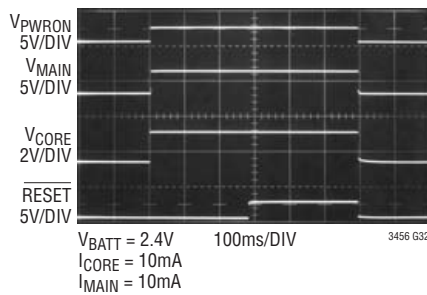

**Power Supply Sequencing  
(Battery Powered)**

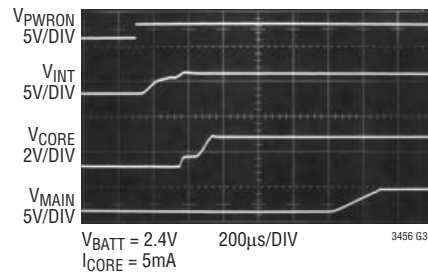

## PIN FUNCTIONS

**AIN (Pin 1):** Low-Battery Detector Input Pin. The detector compares the voltage on this pin to an 800mV reference. Connect the resistor divider tap to this pin to set the low-battery trip point.

**AO (Pin 2):** Open-Drain Digital Output. This open-drain logic output is pulled to GND whenever the AIN pin voltage falls lower than 0.8V.

**AGND (Pin 3):** Analog Ground. All resistor dividers should be connected to this pin.

**V<sub>BATT</sub> (Pin 4):** Battery Input Supply. The input voltage at this pin can range from 1.8V to 3.2V. Must be locally bypassed with a 1 $\mu$ F (or greater) X5R or X7R type ceramic capacitor.

**SW1 (Pin 5):** Switch Pin for Core Regulator. Connect the inductor between SW1 and the output capacitor. Keep these PCB trace lengths as short and wide as possible to reduce EMI.

**PGND (Pin 6):** Power Ground. This is the ground pin for all internal drivers and switches. Provide a short PCB path between PGND and PCB system ground.

**WALLFB (Pin 7):** Wall Feedback Pin. This pin receives the feedback voltage from an external resistor divider across the AC wall adapter input. When the pin voltage is higher than 1.25V, the chip is powered from the V<sub>EXT</sub> pin and the USB switch is turned off. Ensure that the resistor ratio is set so that the wall adapter voltage (min) is still high enough to make V<sub>EXT</sub> > 4V. Connect to ground if not used.

**EXT\_PWR (Pin 8):** External Power Good Pin. This open-drain logic output is pulled to GND whenever the WALLFB pin is pulled higher than 1.25V or the USB pin voltage is greater than 4V and SUSPEND is low. Essentially this pin is pulled low whenever the AC adapter or the USB power is present. When pulled low, this pin is capable of sinking 5mA suitable for driving an external LED.

**V<sub>EXT</sub> (Pin 9):** External Power Pin. This pin is connected to the USB pin via an internal 0.5 $\Omega$  (typ) PMOS switch. The AC wall adapter can be connected to this pin through a Schottky diode. An onboard voltage detector prevents the IC from drawing power from this pin until the pin voltage rises above 4V. The voltage detector for V<sub>EXT</sub> has built-in 150mV hysteresis. Connect a 10 $\mu$ F X5R or X7R type ceramic capacitor from this pin to ground.

**USB (Pin 10):** USB Input Supply. Input current into this pin is limited to either 100mA or 500mA based on the state of the USBHP pin. When the USB pin voltage is greater than 4V and SUSPEND is low, and WALLFB is less than 1.25V, USB is connected to the V<sub>EXT</sub> pin via an internal 0.5 $\Omega$  current limited PMOS Switch. Connect a 4.7 $\mu$ F (X5R or X7R type) ceramic capacitor in series with a 1 $\Omega$  resistor from this pin to ground.

**V<sub>MAX</sub> (Pin 11):** Maximum Supply Voltage Pin. A special internal PowerPath™ controller monitors the V<sub>BATT</sub>, V<sub>INT</sub>, V<sub>EXT</sub> and USB voltages and passes the highest available supply voltage to the V<sub>MAX</sub> pin. This pin is used to power some of the internal circuitry of the IC. Connect a 1 $\mu$ F bypass capacitor from this pin to ground. It can be used to supply a maximum of 1mA output load. The V<sub>MAX</sub> output voltage stays alive even when the IC is in shutdown.

**USBHP (Pin 12):** USB High Power Select Pin. This pin is used to set the USB current limit. Pull high to select 500mA current limit (High Power mode); low to select 100mA current limit (Low Power mode). This pin has a weak pull-down current source to ensure that Low Power mode is in effect during start-up.

**SW2\_BK (Pin 13):** Switch Pin for Main Regulator (USB or Wall Powered). Connect the inductor between SW2\_BK and the output voltage. Keep these PCB trace lengths as short and wide as possible to reduce EMI.

**SW2\_BST (Pin 14):** Switch Pin for Main Regulator (Battery Powered). Connect the inductor between SW2\_BST and V<sub>BATT</sub>. Keep these PCB trace lengths as short and wide as possible to reduce EMI.

**V<sub>INT</sub> (Pin 15):** Internal Supply Voltage Pin. The V<sub>INT</sub> voltage is regulated to 3.3V. This pin is used to power most of the internal circuitry of the IC. Do not load this output. Connect an output capacitor from this pin to ground.

**V<sub>MAIN</sub> (Pin 16):** Main Regulator Output Voltage. An internal 0.4 $\Omega$  PMOS switch connects this pin to the V<sub>INT</sub> pin 0.8ms (typ) after the Core voltage comes into regulation. This ensures that V<sub>MAIN</sub> will always power up after Core output during start-up. Connect an output capacitor from this pin to ground.

## PIN FUNCTIONS

**HSO (Pin 17):** Hot Swap Output. An internal  $0.8\Omega$  current limited PMOS switch connects this pin to the  $V_{INT}$  pin 0.5ms after the core voltage comes into regulation. The nominal voltage at this pin is 3.3V. It is short-circuit protected and the current out of this pin is limited to 120mA (typ).

**SUSPEND (Pin 18):** USB Suspend Pin. Pull this pin high to disable all USB functionality. The USB switch connected between USB and  $V_{EXT}$  behaves like a back-to-back diode whenever SUSPEND is pulled high. In Suspend mode the device limits the current drawn from the USB port to  $100\mu\text{A}$  (typ).

**PWRKEY (Pin 19):** Power  $\overline{\text{ON}}$ /OFF Key. Connecting this pin to GND will turn on the IC. This pin is typically used with a momentary-on pushbutton switch to turn on the LTC3456. This pin must be held low until the PWRON pin is pulled high (usually from a microprocessor) in order to keep the IC turned on. This pin has a 400k pull-up resistor to  $V_{MAX}$ .

**PBSTAT (Pin 20):** Power  $\overline{\text{ON}}$ /OFF Key Status Pin. This open-drain output pin indicates the state of the PWRKEY pin to the microcontroller. The pin output follows the state of the PWRKEY pin (PBSTAT goes low when PWRKEY is pulled low).

**PWRON (Pin 21):** Power On Pin. When pulled high this microprocessor controlled pin turns on the IC. This pin has a weak  $1\mu\text{A}$  pull-down current source.

**MODE (Pin 22):** Burst Mode Select Pin. Tie this pin high to allow automatic Burst Mode operation. Burst Mode operation will provide superior efficiency when any of the outputs are operating with very low output currents. Tie this pin low to force PWM operation under all load current conditions. The device operates in forced PWM mode when powered from USB or wall input (irrespective of the state of the MODE pin). Furthermore, at initial power-up, the device operates in forced PWM mode during the 262ms internal delay timeout. This pin has a weak  $1\mu\text{A}$  pull-down current source.

**RESET (Pin 23):** Fault Indicator Output Pin. This open-drain output is active both at power-up and power-down.  $\overline{\text{RESET}}$  is held low at initial power up. When both the Core and Main outputs come into regulation, an internal reset delay timer is activated.  $\overline{\text{RESET}}$  is released at the end of the 262ms timeout. If either Main or Core outputs fall out of regulation during normal operation,  $\overline{\text{RESET}}$  is pulled low. Also,  $\overline{\text{RESET}}$  is pulled low at power-off to prevent spurious turn-on of the microprocessor.

**FB1 (Pin 24):** Feedback Pin for the Core Regulator. The regulator drives the voltage at this pin to 0.8V. Connect the resistor divider tap to this pin. The output voltage of the core regulator can be adjusted from 0.8V to  $V_{BATT(MIN)}$ .

**Exposed Pad (Pin 25):** The Exposed Pad must be soldered to the PCB system ground.

# BLOCK DIAGRAM

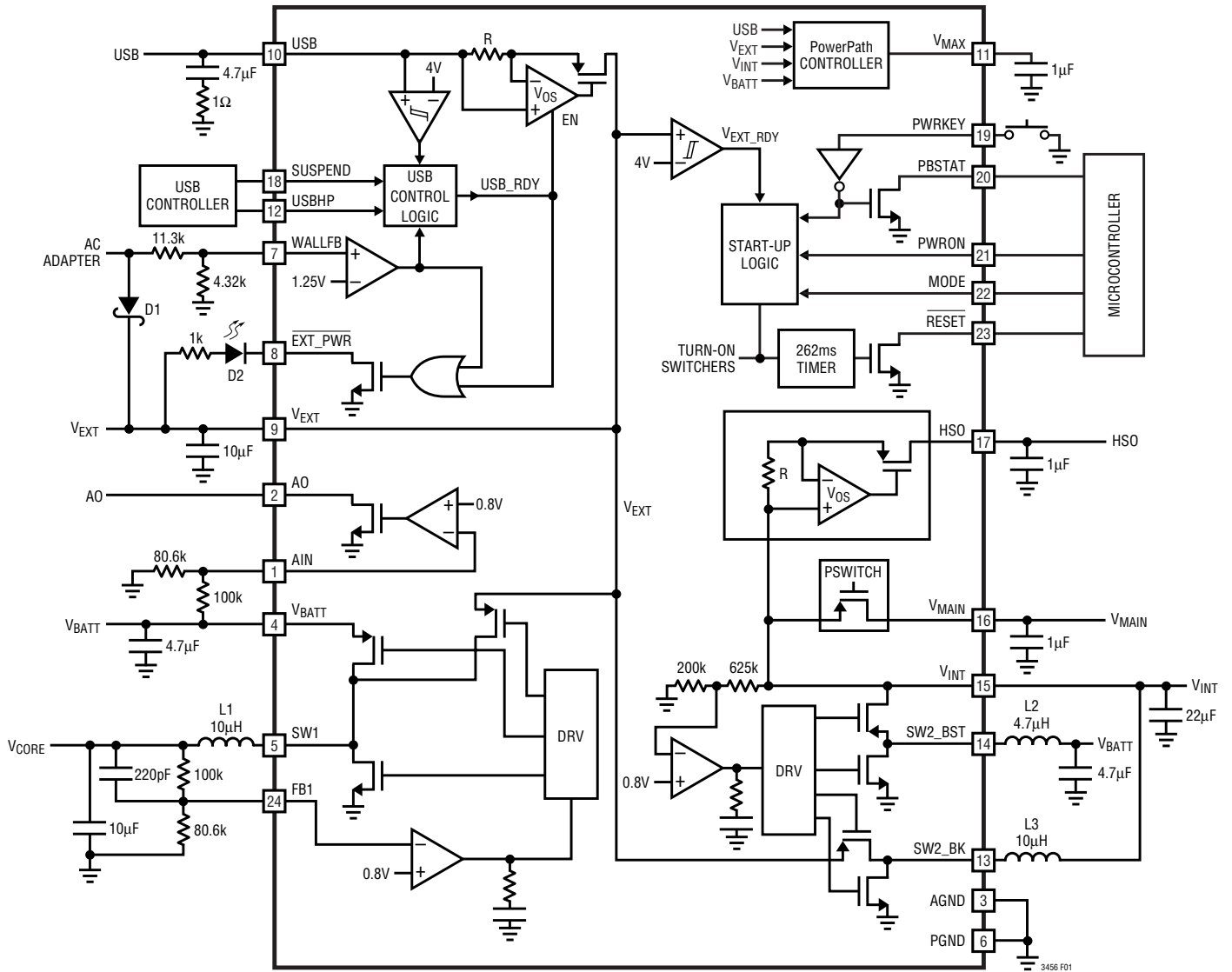

Figure 1. LTC3456 Block Diagram

## OPERATION

### INTRODUCTION

The LTC3456 is a complete system-level power supply IC used to power GPS portable navigators and other portable systems. It takes power from one of three sources: battery, USB or wall adapter. The device provides an integrated standard solution resulting in a reduced parts count and higher efficiency.

The LTC3456 generates two separate power supplies: a Core supply for the processor and a Main supply for the peripheral circuitry. The Main supply is a fixed 3.3V output and the Core supply voltage can be adjusted from 0.8V to  $V_{BATT(MIN)}$ . In addition, the LTC3456 provides a Hot Swap output which can be used for powering flash memory cards. Both regulators utilize a 1MHz constant frequency current mode architecture.

The device also incorporates a low-battery detector (configurable as a low dropout regulator), USB power manager and several protection features in a single package. The LTC3456's control scheme allows 100% duty cycle operation for the core output. It provides low dropout operation when the core output is powered from the battery, thereby extending battery life.

### OPERATING MODES

The LTC3456 is powered from an AC wall adapter, USB or battery, in that order of priority. It has onboard voltage detectors to monitor the status of the wall adapter and USB voltages. The unique control scheme of the LTC3456 allows seamless transition between battery, USB and wall adapter input power sources.

#### Battery Powered

The LTC3456 is designed to accept an input battery voltage range from 1.8V to 3.2V. This range is ideal for 2-cell Alkaline, NiCd or NiMH designs. Figure 2 shows an LTC3456 being powered from two AA cells.

When enabled, the internal supply voltage  $V_{INT}$  (3.3V) is generated via the boost regulator.  $V_{INT}$  is used to power the bandgap reference, drivers and other internal circuitry. Core output (1.8V) comes up next via the buck regulator. Main output and the Hot Swap output are powered up with a delay after the core output is in regulation.

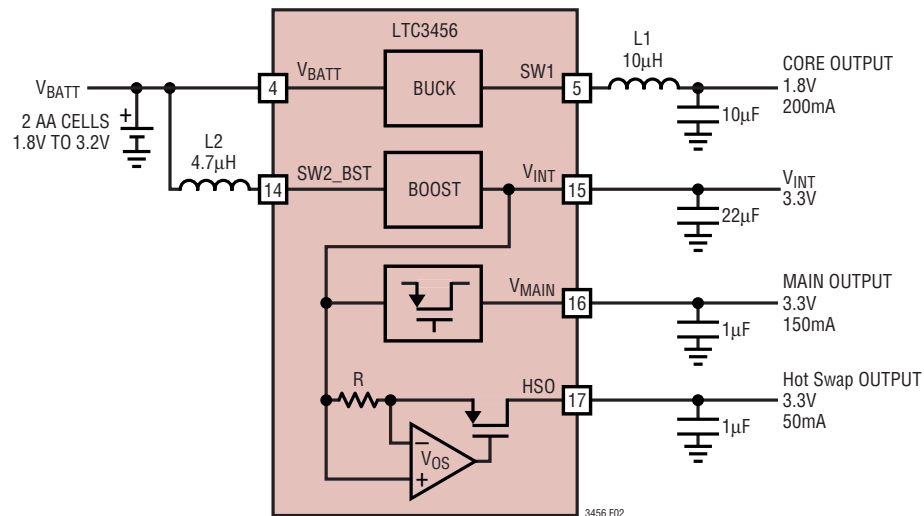

Figure 2. Battery-Powered LTC3456

## OPERATION

### AC Wall Adapter Powered

The LTC3456 can be powered off the AC wall adapter as shown in Figure 3. The wall adapter is connected to the  $V_{EXT}$  pin via the diode D1.

The status of the AC wall adapter power is monitored through the WALLFB pin. The nominal voltage at this pin is 1.25V. When the pin voltage is higher than 1.25V, the IC

will draw all its power from the AC adapter via the  $V_{EXT}$  pin. The WALLFB voltage should always be kept below 2V.

When enabled, the onboard voltage detector checks the status of the  $V_{EXT}$  voltage. If the  $V_{EXT}$  pin voltage is greater than 4V, the  $V_{INT}$ , Core output, Main output and Hot Swap outputs power-up in that sequence.

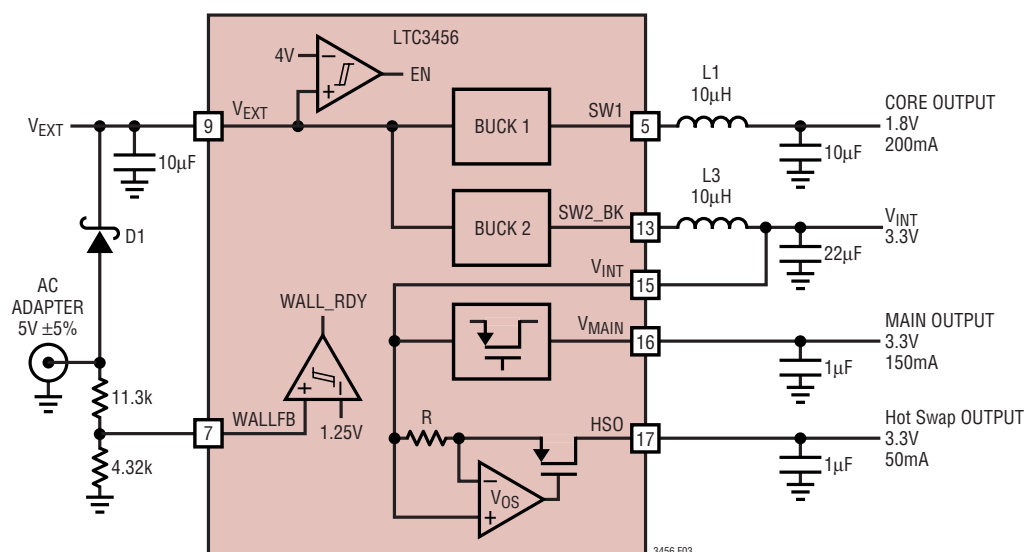

Figure 3. AC Adapter-Powered LTC3456

## OPERATION

### USB Powered

The LTC3456 is designed to be powered from the USB as shown in Figure 4. The LTC3456 has an internal current-limited  $0.5\Omega$  (typ) PMOS switch with preset 0.1A and 0.5A current limits. The LTC3456 interfaces with the USB controller bus via logic pins USBHP and SUSPEND.

The USBHP pin is used to set the USB current limit to either 100mA or 500mA. This pin has a weak  $2.5\mu\text{A}$  pull-down current source to ensure that Low Power mode is in effect during start-up. If the USBHP pin is held low, it limits the input power drawn from the USB port. The USB port can supply the Core output (1.8V at 200mA) effortlessly in Low Power mode (USBHP = 0V). However, the loading on the 3.3V output must be held below 100mA (typ) when the USB is in low power mode. If the loading on 3.3V output is increased beyond 100mA (typ), the USB port is unable to supply the load current and the LTC3456 will switch between the battery and the USB port. This results in undesirable switching noise and increased voltage ripple at the 3.3V output.

Pulling the SUSPEND pin logic high disables all USB functionality. The USB switch connected between USB and  $V_{\text{EXT}}$  behaves like a back-to-back diode whenever SUSPEND is pulled high. In Suspend mode the device limits the current drawn from the USB pin to  $100\mu\text{A}$  (typ).

The minimum voltage to a USB-powered device may drop as low as 4.35V due to cable and connector drops. The LTC3456 has an internal voltage monitor that checks the USB supply voltage and cuts off the USB power if the USB voltage falls below 4V. There is 75mV of hysteresis built-in the USB voltage monitor.

When the IC is enabled, the USB pin is connected to the  $V_{\text{EXT}}$  pin via the PMOS switch. The  $V_{\text{EXT}}$  pin gets charged by the preset 0.1A or 0.5A current limit determined by the state of the USBHP pin. As the  $V_{\text{EXT}}$  pin voltage rises above 4V, the  $V_{\text{INT}}$ , Core output, Main output and Hot Swap outputs power-up in that sequence.

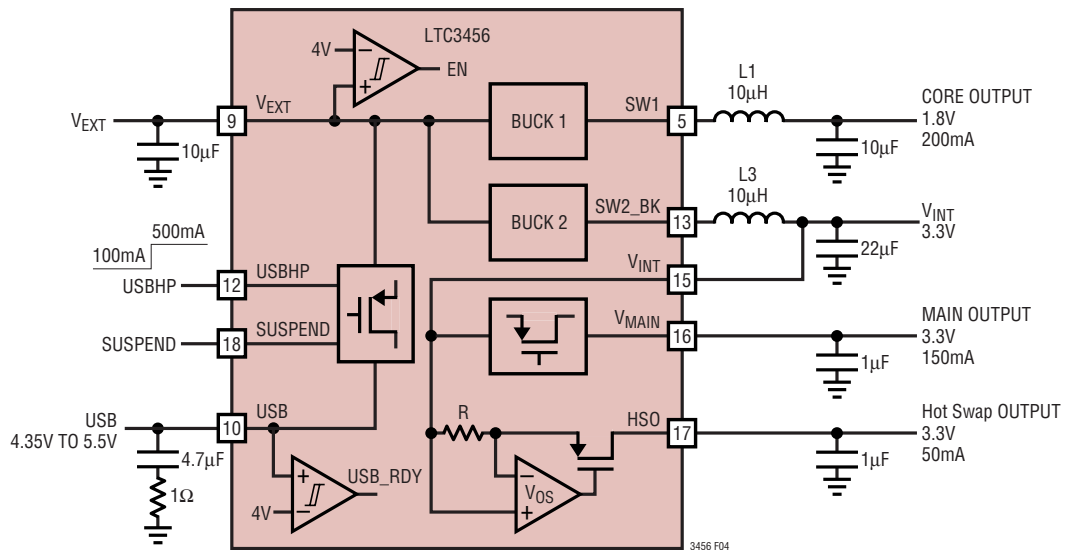

Figure 4. USB-Powered LTC3456

## OPERATION

### MAIN REGULATOR

#### $V_{INT}$ Output

The main regulator produces a fixed 3.3V output from a 1.8V to 3.2V input (2-cell battery), USB port or AC adapter input supply. The main regulator output,  $V_{INT}$ , is used to power most of the internal circuitry of the IC. It is the first one to power-up. Connect a 22 $\mu$ F or higher X5R or X7R type ceramic capacitor from this pin to ground.

The loading on this output should be limited to 20mA. Refer to the Minimum Start-Up Battery Voltage vs  $V_{INT}$  Output Current graph in the Typical Performance Characteristics.

When the IC is turned off, the  $V_{INT}$  output voltage is discharged to ground.

#### Output Disconnect and Inrush Limiting

The LTC3456 allows true output disconnect when powered off the battery (boost topology). It achieves this by disconnecting the body diode of the synchronous PMOS switch from the output. This allows the  $V_{INT}$  to go to ground during shutdown. Do not connect a Schottky diode from SW2\_BST to  $V_{INT}$ ; doing so will defeat the output disconnect feature.

The LTC3456 also features inrush current limiting at power-up (battery powered). Inrush current in boost converters is important when powering from input sources with high input impedance like alkaline cells. The LTC3456 incorporates an inrush current limiting scheme that regulates the inrush current to 600mA (typ) during power-up.

Figure 5 shows inrush current when the device is powered up from the battery.

#### Short-Circuit Protection

The LTC3456 features short-circuit protection for the main regulator output. When the main regulator is powered from the USB or wall input, it operates in a buck topology.

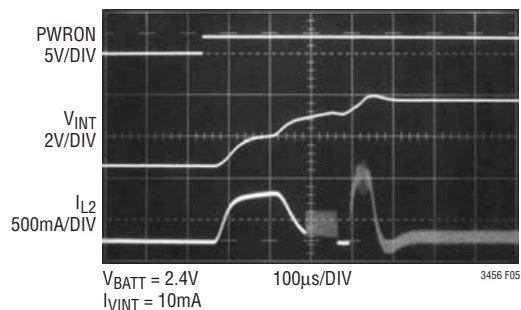

Figure 5. Inrush Current at Power-Up (Battery Powered)

If the main regulator outputs ( $V_{INT}$  or  $V_{MAIN}$ ) are shorted to ground, the LTC3456 unique control scheme prevents inductor current runaway.

When the device is powered from the battery, it operates in a boost topology. Most boost converters do not allow their outputs to be shorted to ground. However, the LTC3456 allows the output of its main regulator ( $V_{INT}$  or  $V_{MAIN}$ ) to be short-circuited due to its unique inrush current limiting. In the event of a short-circuit, the input current is well regulated.

#### $V_{MAIN}$ Output

The LTC3456 is designed to supply power to the microprocessor peripheral circuitry in a controlled manner. The peripheral circuitry should be connected to the  $V_{MAIN}$  output.

$V_{MAIN}$  is connected to  $V_{INT}$  via a 0.4 $\Omega$  (typ) PMOS switch 0.8ms (typ) after the Core output comes into regulation. This ensures that the peripheral circuitry always powers up after the microprocessor.

The  $V_{MAIN}$  output is discharged to ground through internal pull-down resistors at shutdown. This ensures that the peripheral circuitry gets turned-off completely during shutdown. Connect a 1 $\mu$ F (X5R or X7R) bypass capacitor from this pin to ground.

## OPERATION

### Hot Swap Output

The LTC3456 is designed to supply power to flash memory cards. It has a built-in Hot Swap output, HSO, which allows memory cards to be hot swapped into and out of the system. The Hot Swap output features short-circuit and reverse-voltage blocking protection. Connect a  $1\mu\text{F}$  (X5R or X7R) bypass capacitor from this pin to ground.

After the  $V_{\text{INT}}$  and Core output voltages come into regulation, the HSO pin is connected to  $V_{\text{INT}}$  via a  $0.8\Omega$  (typ) PMOS switch after a delay of 0.5ms. The PMOS switch has a 120mA built-in current limit. When a flash memory card is plugged into the system, the input bypass capacitors are slowly charged up to 3.3V with the preset 120mA current limit. Figure 6 shows the switching waveforms with Hot Swap output short-circuited. As seen in the figure, the short-circuited current out of the HSO pin is well regulated.

The LTC3456 also features reverse-voltage blocking capability for the HSO pin. In the event the HSO pin voltage rises greater than 3.3V ( $V_{\text{INT}}$  pin voltage), the internal PMOS switch is turned off and behaves like a back-to-back diode.

During shutdown, the Hot Swap output is discharged to ground via internal pull-down resistors.

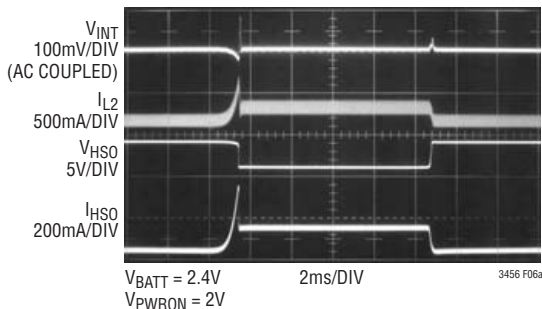

Figure 6a. Short-Circuit at the Hot Swap Output (Battery Powered)

### CORE REGULATOR

The core regulator produces a 0.8V to 1.8V adjustable output from a 1.8V to 3.2V input (2-cell battery), USB port or AC adapter supply. The core regulator utilizes a synchronous N-channel MOSFET, improving efficiency and eliminating the need for an external Schottky diode. The core output voltage is measured at the FB1 pin through a resistive divider network. The nominal voltage at the FB1 pin is 0.8V. The divider can be adjusted to set the output voltage level. The FB1 voltage should always be kept below 2V.

The LTC3456 internal soft-start circuitry limits current drawn at start-up. Soft-start is essential for input sources with high input impedance like alkaline cells. Soft-start is implemented by ramping up the current limit. At start-up, the current limit is set to 25% and increased by 25% every  $256\mu\text{s}$ . The final inductor current limit is reached after 1ms.

When the core regulator is turned off, the output voltage  $V_{\text{CORE}}$  is discharged to ground. This is accomplished by pulling the switching node, SW1, to ground through the internal pull-down resistors.

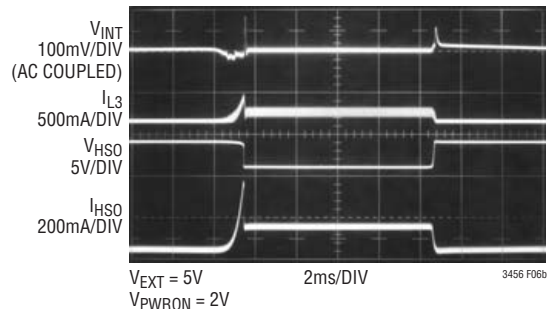

Figure 6b. Short-Circuit at the Hot Swap Output (Wall/USB Powered)

## OPERATION

The LTC3456 incorporates additional features like output short-circuit protection and thermal regulation. When the core regulator output ( $V_{CORE}$ ) is shorted to ground, the LTC3456's unique control scheme prevents inductor current runaway.

### Dropout Operation

The LTC3456 is capable of operating at 100% duty cycle when powered from the battery. If the input supply voltage decreases to a value close to the output voltage, the core regulator will run at 100% duty cycle. The output voltage is then determined by the input voltage minus the voltage drop across the PMOS switch and the inductor. When running off the USB or the AC adapter, this situation never arises (there is plenty of voltage headroom).

When the LTC3456 operates with low input supply voltage, say 1.8V (fully discharged two AA cells) the maximum allowable output current gets reduced. Figure 7 shows the reduction in the maximum output current as a function of input voltage for various output voltages.

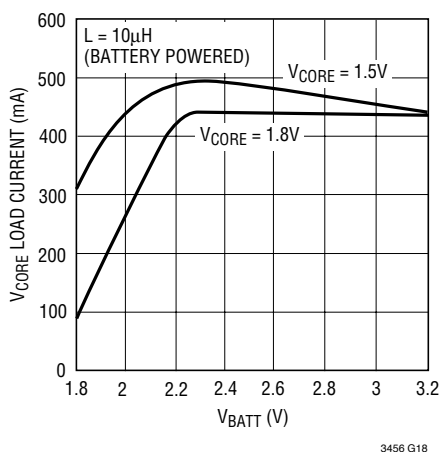

Figure 7. Maximum Output Current vs Battery Voltage

### V<sub>MAX</sub> OUTPUT

A special internal PowerPath controller monitors the  $V_{BATT}$ ,  $V_{INT}$ ,  $V_{EXT}$  and USB voltages and passes the highest available supply voltage to the  $V_{MAX}$  pin. This pin is used

to power some of the internal circuitry of the IC. Connect a 1 $\mu$ F bypass capacitor from this pin to ground. It can be used to supply a maximum of 1mA output load.

The  $V_{MAX}$  output voltage stays alive even when the IC is in shutdown. During shutdown, the  $V_{MAX}$  output will be the highest of  $V_{BATT}$ ,  $V_{EXT}$  and USB voltages.  $V_{MAX}$  output can be used to supply power to a critical block like the real-time clock, which needs to stay alive even during shutdown.

## POWER SEQUENCING

### Power On/Off

The LTC3456 can be turned on in two different ways:

- Pulling the PWRKEY pin low
- Pulling the PWRON pin high

Pulling the PWRKEY pin low is usually the first step in turning on the LTC3456. When PWRKEY is pulled low, it powers on the bandgap reference. Onboard voltage monitors check the status of the AC adapter and USB supply. The IC is powered from either the AC adapter, USB or the battery, in that order of preference. The  $V_{INT}$  voltage powers up, followed by the Core, Main and Hot Swap outputs.

At initial power up, the  $\overline{RESET}$  pin is held low. When the Core output comes into regulation, the  $\overline{RESET}$  timer is started. After a 262ms timeout, the  $\overline{RESET}$  pin is released. This allows the microprocessor to turn on. The microprocessor in turn pulls PWRON high. After the PWRON pin is pulled high, the PWRKEY pin can be released. There is a 400k $\Omega$  pull-up resistor on the PWRKEY pin.

The PWRKEY pin serves the dual purpose of turning on and off the IC. During regular operation, if PWRKEY is pressed low, the microprocessor detects this by monitoring the status of PBSTAT pin. The PBSTAT pin goes low whenever the PWRKEY pin is pulled low. The microprocessor then goes into shutdown mode and pulls the PWRON pin low. This results in powering off the LTC3456. Figure 8 shows the device power-on/power-off sequence.

## OPERATION

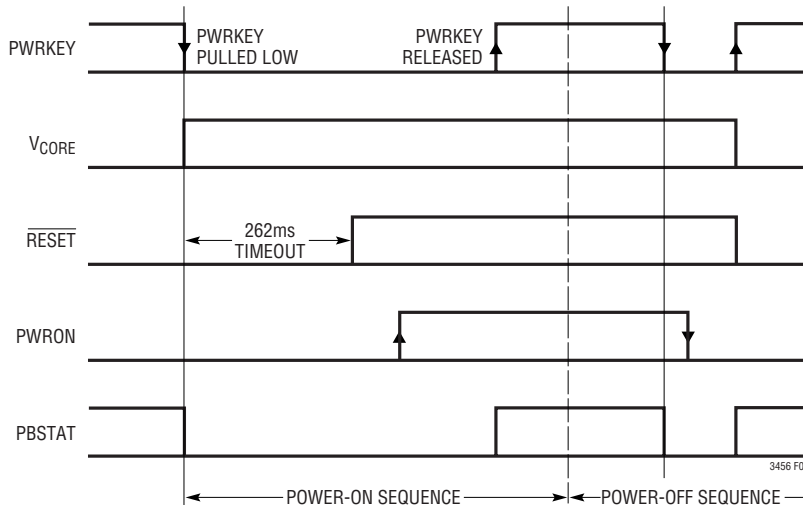

Figure 8. Power-On/Power-Off Sequence

### RESET

The LTC3456 contains a  $\overline{\text{RESET}}$  circuitry that is active during both power-up and shutdown. The  $\overline{\text{RESET}}$  pin is held low during initial power-up. When both the  $V_{\text{INT}}$  and Core outputs come into regulation, a reset delay timer gets activated. There is a full 262ms timeout before  $\overline{\text{RESET}}$  is released. During power-off mode  $\overline{\text{RESET}}$  is pulled low. This prevents the microprocessor from entering into any spurious operating mode.

### MODE

The LTC3456 has a user selectable MODE pin. When the MODE pin is pulled logic high and the LTC3456 is battery powered, the device will automatically enter into Burst Mode operation under light load current situations. If the load current in either of the regulators falls below a predetermined value, the regulator will enter into Burst Mode operation independent of the other regulator. When the MODE pin is connected to ground, continuous PWM operation is selected. It provides the lowest output voltage ripple and current ripple, albeit at the cost of lower efficiency under light load conditions.

The Burst Mode operation is disabled when the device is USB or wall powered. The device operates in forced PWM mode when powered from USB or wall input (irrespective of the state of the MODE pin). Also, at initial power up, the device operates in forced PWM mode during the 262ms initial delay timeout.

Figure 9 shows the Main and Core converters in Burst Mode operation.

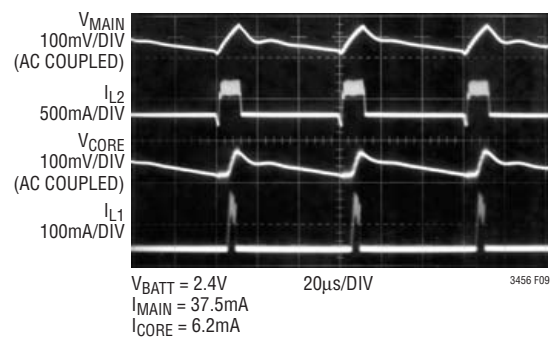

Figure 9. The LTC3456 in Burst Mode Operation

## OPERATION

### VOLTAGE MONITORS

#### Low-Battery Detection

The LTC3456 has an on-chip gain block that can be used for low-battery detection. The low-battery trip point can be set by two resistors (Figure 10). The nominal voltage at AIN is 0.8V. If the voltage at AIN falls below 0.8V, AO sinks current to ground.

The battery minimum voltage can be set according to the formula:

$$V_{BATT(MIN)} = 0.8V \left( 1 + \frac{R2}{R1} \right)$$

The AIN input bias current is quite low, on the order of 2nA (typ). Large resistor values ( $R2 \sim 100k$ ) can be used in the divider network. This helps in minimizing the loading on the battery. AO is an open-drain logic output. The voltage at AIN must always be kept less than 2V. If the gain block is not used then connect AIN to ground.

There is no built-in hysteresis in the gain block. Hysteresis can be added by connecting resistor R4 from AIN to AO as shown in Figure 10. Ensure that  $R4 \cong 10R3$  for correct operation. With the values shown in Figure 10b, the circuit has 180mV of hysteresis.

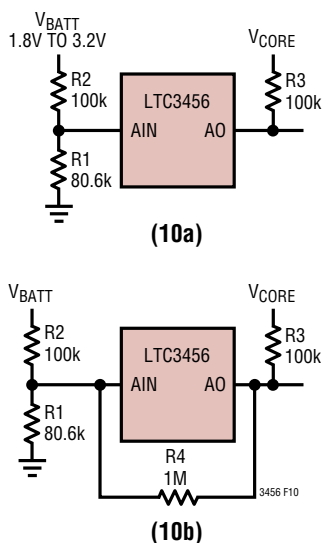

Figure 10. Low-Battery Detector (10a) and Low-Battery Detector with Hysteresis (10b)

The gain block can be configured to drive an external PNP transistor and generate an auxiliary voltage as shown in Figure 11. An auxiliary output voltage 2.5V/20mA is generated from the V<sub>MAIN</sub> (3.3V) power supply.

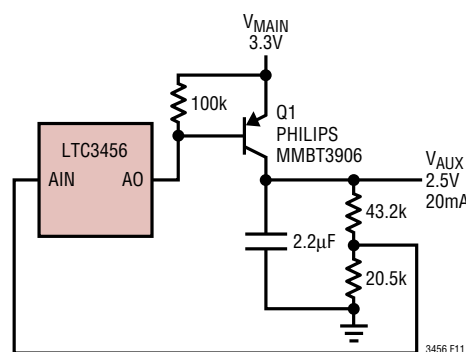

Figure 11. Generating Auxiliary Voltage Supply

#### External Power Detection

The LTC3456 has an  $\overline{EXT\_PWR}$  output pin to indicate the presence of USB or wall power. Whenever the WALLFB pin is pulled higher than 1.25V (AC adapter present), or the USB input is greater than 4V and the  $\overline{SUSPEND}$  pin is low (USB power available), the  $\overline{EXT\_PWR}$  pin is pulled to ground. When pulled low, this pin is capable of sinking 5mA suitable for driving an external LED. Otherwise, this pin is in a high impedance state.

#### Overtemperature Protection

The maximum allowable junction temperature for LTC3456 is 125°C. In normal operation, the IC does not dissipate much heat and its junction temperature stays well below 125°C at an ambient temperature of 85°C or less. If the junction temperature exceeds 150°C, the Core, Main and Hot Swap outputs are turned off and  $\overline{RESET}$  is pulled low.

The V<sub>INT</sub> output stays alive in this state. The Core and Main outputs will remain off until the die temperature falls below 150°C, regardless of the state of the PWRKEY and PWRON inputs.

## APPLICATIONS INFORMATION

### COMPONENT SELECTION

#### Inductor Selection

The high frequency operation of LTC3456 allows the use of small surface mount inductors. For most applications, the inductance value will be between 2.2 $\mu$ H and 10 $\mu$ H. The desired value of inductance is determined by the amount of ripple current,  $\Delta I_L$ , in the converter.

The inductor current ripple,  $\Delta I_L$ , for Boost mode operation neglecting the voltage drop across the switches is given by:

$$\Delta I_L = \frac{V_{IN} \cdot (V_{OUT} - V_{IN})}{V_{OUT} \cdot f \cdot L}$$

The inductor current ripple,  $\Delta I_L$ , for Buck mode operation neglecting the voltage drop across the switches is given by:

$$\Delta I_{L1} = \frac{V_{OUT} \cdot (V_{IN} - V_{OUT})}{V_{IN} \cdot f \cdot L}$$

where

L = Inductor

f = Operating Frequency

$V_{IN}$  = Input Voltage

$V_{OUT}$  = Output Voltage

The  $\Delta I_L$  is typically set to 20% to 40% of the maximum inductor current.

The inductor should have a saturation current rating greater than the peak inductor current required for the application. Also, ensure that the inductor has a low DCR (copper wire resistance) to minimize  $I^2R$  power losses.

Several inductors that work well with the LT3456 are listed in Table 1. Consult each manufacturer for more detailed information and for their entire selection of related parts.

**Table 1. Recommended Inductors**

PART	L ( $\mu$ H)	MAX DCR ( $\Omega$ )	CURRENT RATING (mA)	VENDOR
ELT5KT-4R7 ELT5KT-100	4.7 10	0.2 0.36	950 680	Panasonic (714) 373-7939 www.panasonic.com
CDRH4D18-4R7 CDRH4D18-100	4.7 10	0.16 0.2	840 610	Sumida (847) 956-0666 www.sumida.com
LQH32CN4R7 LQH32CN100	4.7 10	0.15 0.3	650 450	Murata (814) 237-1431 www.murata.com
1002AS-4R7M 1002AS-100M	4.7 10	0.19 0.32	910 620	Toko (800) 745-8656 www.toko.com

#### Output Capacitor Selection

Low ESR (equivalent series resistance) capacitors should be used at the output to minimize the output ripple voltage. Multilayer ceramic capacitors are an excellent choice, as they have an extremely low ESR and are available in very small packages. Use only X7R or X5R dielectrics, as these materials retain their capacitance over wider voltage and temperature ranges than other dielectrics. A 1 $\mu$ F to 22 $\mu$ F output capacitor is sufficient for most applications. Solid tantalum or OS-CON capacitors can be used, but they will occupy more board area than a ceramic and will have a higher ESR for the same device footprint. Always use a capacitor with a sufficient voltage rating.

Table 2 shows a list of several ceramic capacitor manufacturers. Consult the manufacturers for detailed information on their entire selection of ceramic parts.

**Table 2. Ceramic Capacitor Manufacturers**

Taiyo Yuden	(408) 573-4150 www.t-yuden.com
AVX	(803) 448-9411 www.avxcorp.com
Murata	(714) 852-2001 www.murata.com
TDK	(847) 803-6100 www.component.tdk.com

## APPLICATIONS INFORMATION

### Input Capacitor Selection

The LTC3456 can be powered from three different power sources: battery, USB or the AC wall adapter. Choose a 4.7 $\mu$ F or higher X5R or X7R type ceramic capacitor for bypassing the input of LTC3456.

However, special care must be taken when bypassing the USB and AC wall adapter inputs with ceramic capacitors. Ceramic capacitors with their low ESR can form a resonant tank circuit with the stray wiring inductance of the power leads. This can cause large voltage transients at the input of the device when the power is applied quickly (for example, plugging the AC adapter output into the portable device). This voltage spike can be large enough to damage the LTC3456. A possible solution is to clamp the input voltage or insert a small resistor in series with the ceramic capacitor as shown in Figure 12. Please refer to Linear Technology Application Note AN88 for more details.

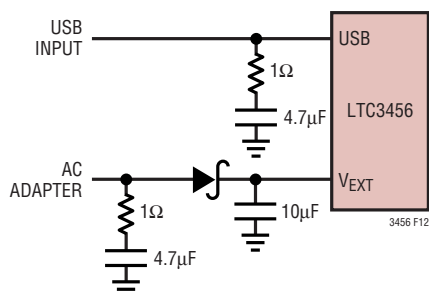

Figure 12. Bypassing USB and AC Wall Adapter Inputs

Figure 13(a) shows the voltage waveforms at the USB and V<sub>EXT</sub> pins resulting from hot-plugging a 5.5V input supply. As seen in the figure, there is a large voltage transient (in excess of 8V) at the USB input pin. This voltage spike exceeds the 6V absolute maximum voltage rating of the pin, and can cause serious performance degradation or, even complete failure of the part. The spike can be greatly reduced by adding a 1 $\Omega$  series resistor with the 4.7 $\mu$ F ceramic capacitor, as seen in Figure 13(b). The voltage ringing at the USB pin is completely removed and the maximum voltage spike at the USB pin is less than the maximum voltage rating of 6V.

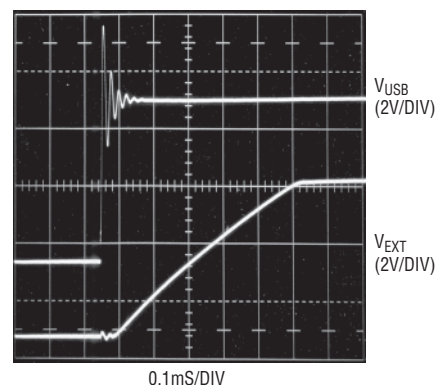

Figure 13(a). Hot-Plugging the USB Power (5.5V Input) with a 4.7 $\mu$ F Ceramic Capacitor Used for Bypassing.

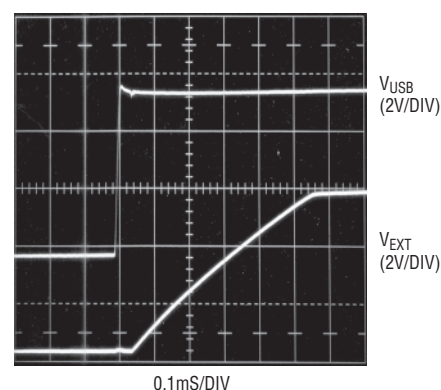

Figure 13(b). Hot-Plugging the USB Power (5.5V Input) with a 4.7 $\mu$ F Ceramic Capacitor and 1 $\Omega$  Series Resistor Used for Bypassing

### Output Voltage Programming

The output of the core converter can be set by a resistor divider according to the formula:

$$V_{\text{CORE}} = 0.8V \left( 1 + \frac{R2}{R1} \right)$$

The external resistor divider is connected at the output as shown in Figure 14. Choose 1% resistors for better accuracy. R1 should be 80.6k or smaller for better noise immunity.

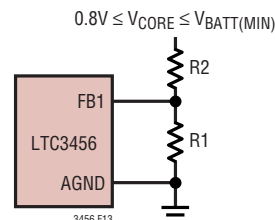

Figure 14. Setting the Core Output Voltage

## APPLICATIONS INFORMATION

### AC ADAPTER UVLO VOLTAGE PROGRAMMING

The AC wall adapter UVLO voltage can be set by a resistor divider connected across the AC wall adapter as shown in Figure 15.

The AC wall adapter UVLO voltage can be set by a resistor divider according to the formula:

$$V_{\text{ADAPTER(MIN)}} = 1.25\text{V} \left( 1 + \frac{R2}{R1} \right)$$

Choose 1% resistors for better accuracy. When the WALLFB pin voltage is higher than 1.25V, the LTC3456 will be powered from the V<sub>EXT</sub> pin. The internal USB power switch is turned off and the power is derived from the AC adapter through the diode D1. Ensure that the AC adapter UVLO voltage is set high enough to make V<sub>EXT</sub> > 4V during regular operation.

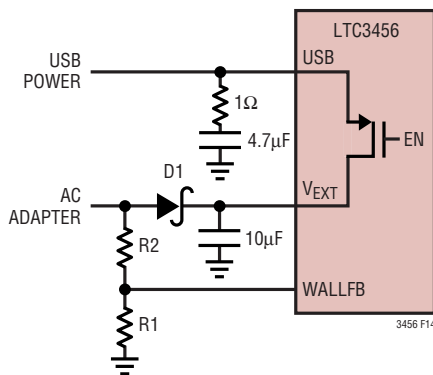

Figure 15. Setting the Wall Adapter UVLO Voltage

When the device is powered from the USB input (AC adapter is not present), the V<sub>EXT</sub> pin is charged close to the USB voltage. The reverse leakage current of the diode D1 flows through R1 and R2 as shown in Figure 16. If the leakage current is large enough to pull the WALLFB pin above 1.25V, then the USB power is switched off. The LTC3456 will then enter into a hiccup mode with USB power being turned on and off in a periodic fashion.

A 4.32k or smaller resistor should be chosen for R1 to prevent this behavior. When the power is being delivered from the wall adapter, efficiency is not a big concern and choosing small value R1 and R2 resistors should be acceptable.

Connect the WALLFB pin to ground if the wall adapter is not used.

### Rectifier Diode Selection

The diode, D1, shown in Figures 15 and 16 is used to connect the V<sub>EXT</sub> pin to the AC adapter input. The IC is powered through the diode D1 when running off the AC adapter. A Schottky diode is recommended to minimize the voltage drop from the AC adapter to the V<sub>EXT</sub> pin.

$$V_{\text{EXT(MIN)}} = V_{\text{ADAPTER(MIN)}} - V_{\text{DIODE(MAX)}}$$

Always ensure that V<sub>EXT</sub> > 4V during regular operation. Choose a diode with a current rating high enough to handle the input current.

Choose a Schottky diode with low reverse leakage current (as explained in previous section). ON Semiconductor MBRM120E (20V/1A) is a good choice for a low leakage Schottky rectifier.

The Zetex ZLLS400 (40V/0.5A) Schottky diode is available in a small surface mount package and is also a good fit for this application.

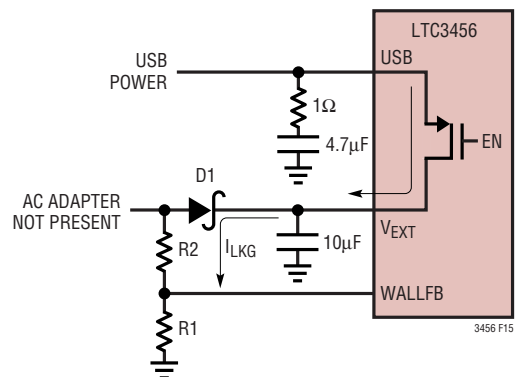

Figure 16. Diode D1 Leakage Current Flow in USB Powered Mode

## APPLICATIONS INFORMATION

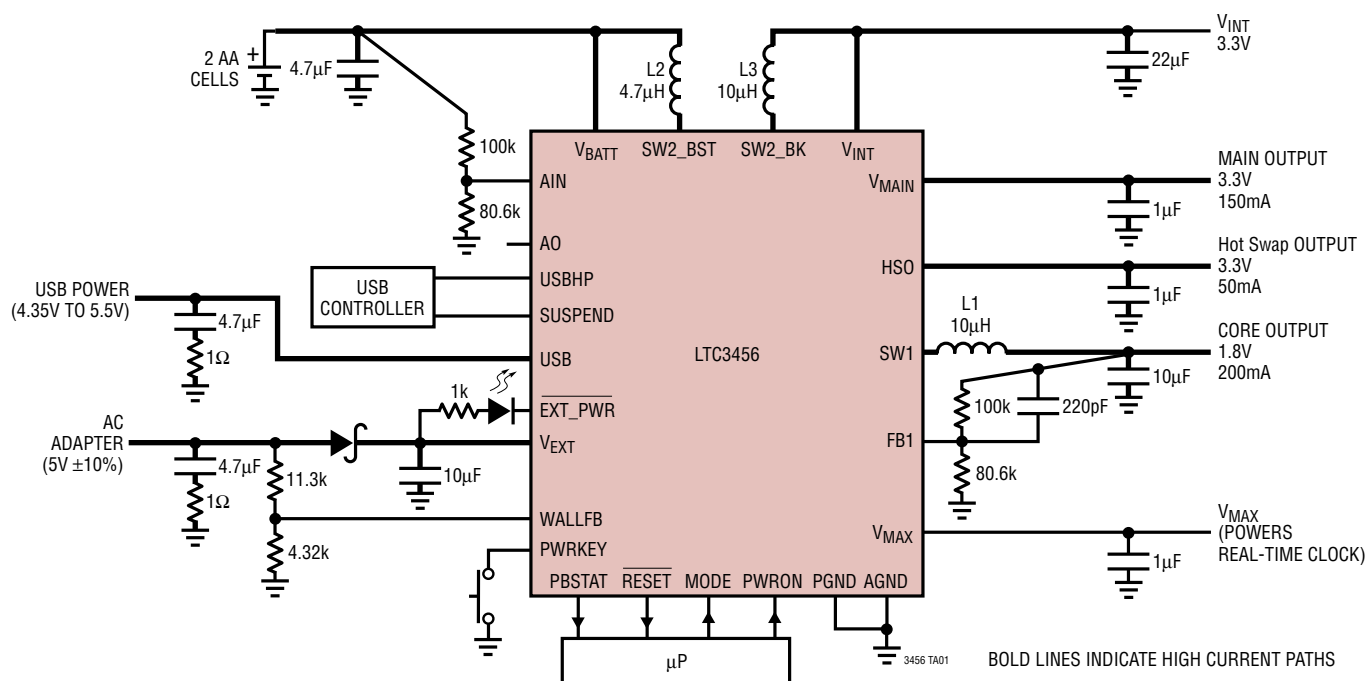

Figure 17. Layout Diagram

## BOARD LAYOUT CONSIDERATION

As with all switching regulators, careful attention must be paid to the PCB board layout and component placement. To prevent electromagnetic interference (EMI) problems, proper layout of high frequency switching paths is essential. Minimize the length and area of all traces connected to the switching node pins (SW1, SW2\_BK, SW2\_BST). Keep the feedback pins FB1 and AIN away from the switching nodes. The power traces shown as bold lines in Figure 17 should be kept short, direct and wide.

The QFN package has an exposed paddle and it must be connected to the system ground. The ground connection for the feedback resistors should be tied directly to the ground plane and not shared with any other component, ensuring a clean, noise-free connection.

## DESIGN EXAMPLE

As a design example, we target a 2 AA cell powered GPS navigator application. Figure 18 shows LTC3456 being used to provide power to the core and I/O peripherals. The flash memory card is powered from the Hot Swap output.

Core output needs to be 1.8V and the maximum load current is 200mA. The inductor current ripple,  $\Delta I_L$ , for buck mode of operation is given by:

$$\Delta I_{L1} = \frac{V_{OUT} \cdot (V_{IN} - V_{OUT})}{V_{IN} \cdot f(L1)}$$

The maximum inductor current in L1 is set by the core converter current limit; i.e., 400mA (minimum). Choosing  $\Delta I_L = 100\text{mA}$  (~25% of peak inductor current) is a reasonable starting value.

Substituting  $V_{OUT} = 1.8\text{V}$ ,  $V_{IN(\text{MAX})} = 3.2\text{V}$ ,  $\Delta I_{L1} = 100\text{mA}$ ,  $f = 1\text{MHz}$  in above equation gives:

$$L1 = \frac{1.8\text{V} \cdot (3.2\text{V} - 1.8\text{V})}{3.2\text{V} \cdot 100\text{mA} \cdot 1\text{MHz}} = 7.8\mu\text{H}$$

## APPLICATIONS INFORMATION

We can choose a low resistance 7.8 $\mu$ H or slightly higher value inductor. We can choose a 450mA, 10 $\mu$ H inductor (Murata LQH32CN100).

We need to check the ripple current when the core output is powered from the AC adapter or the USB. L1 is used to power the output in this case too.

Substituting  $V_{OUT} = 1.8V$ ,  $V_{IN(MAX)} = 5.5V$ ,  $L1 = 10\mu H$ ,  $f = 1MHz$  in above equation gives:

$$\Delta I_{L1} = \frac{1.8V \cdot (5.5V - 1.8V)}{5.5V \cdot 10\mu H \cdot 1MHz} = 120mA$$

L1 gives a reasonable value of ripple current when powered from both battery and USB or AC adapter.

The main output needs to be 3.3V and the maximum load current is 200mA. Hot Swap current is derived from the same main converter.

When powered from the 2 AA cell, the 3.3V output is generated via the L2 boost inductor. The inductor current ripple,  $\Delta I_{L2}$ , for Boost mode operation is given by:

$$\Delta I_{L2} = \frac{V_{IN} \cdot (V_{OUT} - V_{IN})}{V_{OUT} \cdot f(L2)}$$

A reasonable starting value of inductor ripple current is  $\Delta I_{L2} = 150mA$ . Substituting  $V_{OUT} = 3.3V$ ,  $V_{IN(MIN)} = 1.8V$ ,  $\Delta I_{L2} = 150mA$ ,  $f = 1MHz$  in above equation gives:

$$L2 = \frac{1.8V \cdot (3.3V - 1.8V)}{3.3V \cdot 150mA \cdot 1MHz} = 5.4\mu H$$

We can choose a low resistance 4.7 $\mu$ H, 650mA inductor (Murata LQH32CN4R7M53).

When powered from the AC adapter or the USB, the 3.3V output is generated via the L3 buck inductor. The inductor current ripple ( $\Delta I_{L3}$ ) for Buck mode operation is given by:

$$\Delta I_{L3} = \frac{V_{OUT} \cdot (V_{IN} - V_{OUT})}{V_{IN} \cdot f(L3)}$$

A reasonable starting value of inductor ripple current is  $\Delta I_{L3} = 100mA$ . Substituting  $V_{OUT} = 3.3V$ ,  $V_{IN(MAX)} = 5.5V$ ,  $\Delta I_{L3} = 100mA$ ,  $f = 1MHz$  in above equation gives:

$$L3 = \frac{3.3V \cdot (5.5V - 3.3V)}{5.5V \cdot 100mA \cdot 1MHz} = 13.2\mu H$$

We can choose a 450mA, 10 $\mu$ H inductor (Murata LQH32CN100K53).

A 4.7 $\mu$ F to 22 $\mu$ F (X5R or X7R) ceramic output capacitor is sufficient for most applications. They have a low ESR and result in a low output ripple.

Figure 18 shows the complete circuit along with the efficiency curves.

# APPLICATIONS INFORMATION

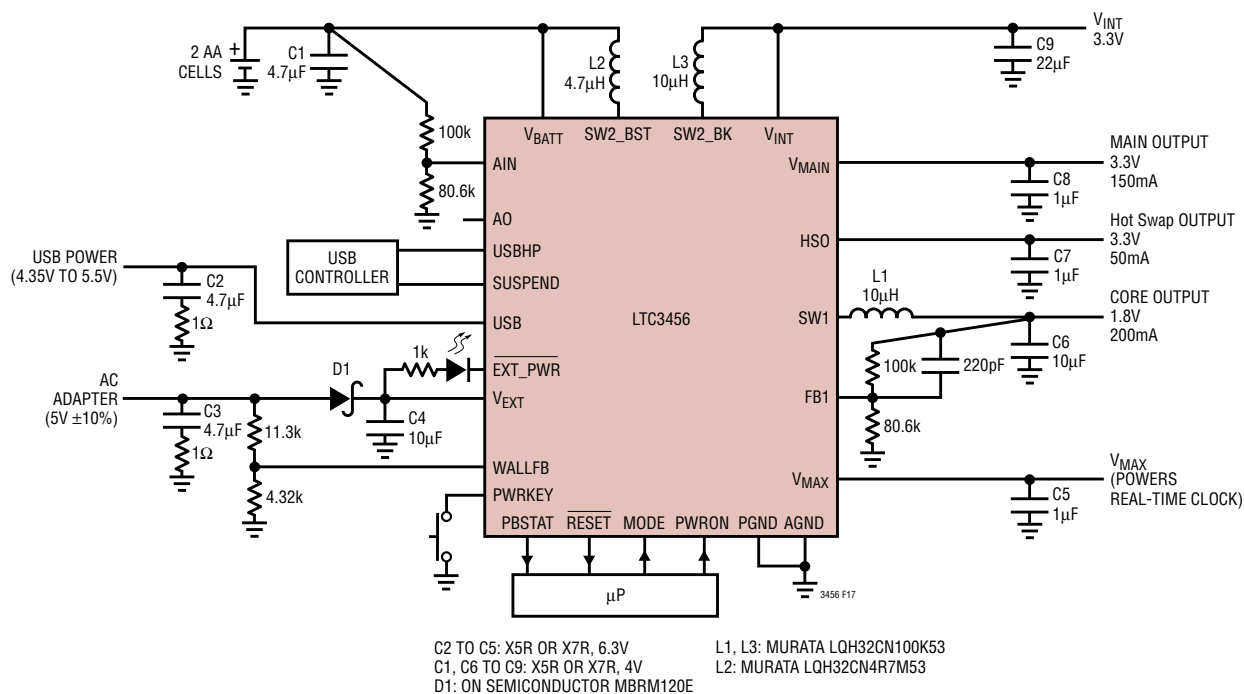
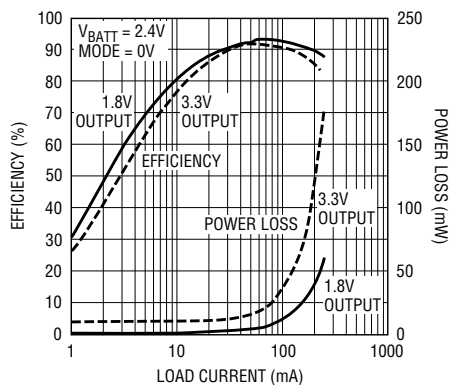
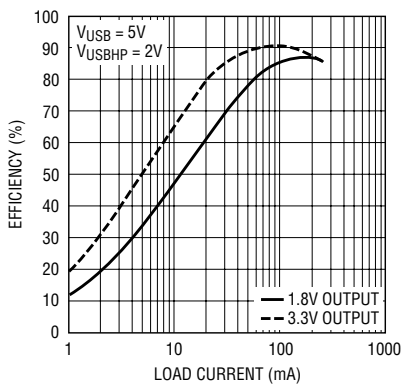

Figure 18. 2 AA Cells to 1.8V/200mA and 3.3V/200mA Outputs Using All Ceramic Capacitors with Lowest Parts Count

Efficiency (Battery Powered)



Efficiency (USB Powered)



Efficiency (Wall Powered)

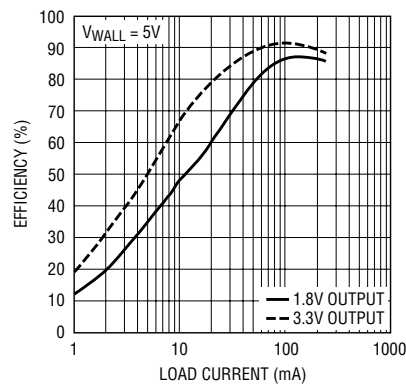

## TYPICAL APPLICATION

### 2 AA Cells Power Complete Power Supply for Handheld Devices

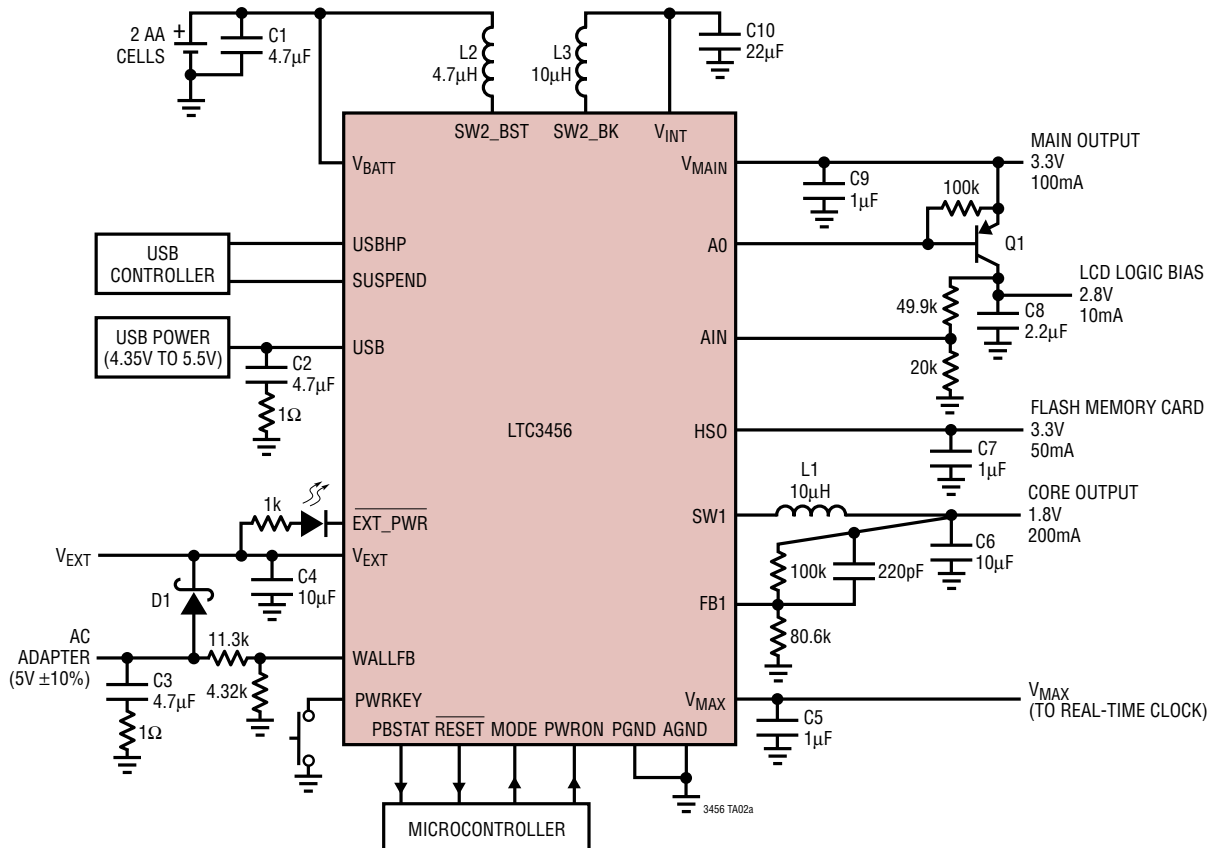

C1, C6 TO C10: X5R OR X7R, 4V  
 C2 TO C5: X5R OR X7R, 6.3V  
 D1: ON SEMICONDUCTOR MBRM120E  
 L1, L3: MURATA LQH32CN100K53  
 L2: MURATA LQH32CN4R7M53  
 Q1: PHILIPS MMBT3906

Load Transient (Battery Powered)

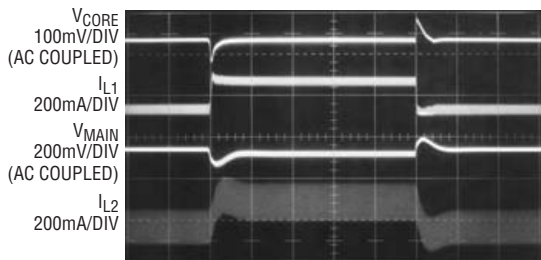

$V_{BATT} = 2.4V$   
 $I_{MAIN} = 20mA$  TO  $100mA$   
 $I_{CORE} = 20mA$  TO  $150mA$   
 100 $\mu s$ /DIV  
 3456 TA02b

Load Transient (USB/Wall Powered)



$V_{EXT} = 5V$   
 $I_{MAIN} = 20mA$  TO  $100mA$   
 $I_{CORE} = 5mA$  TO  $150mA$   
 200 $\mu s$ /DIV  
 3456 TA02c

# PACKAGE DESCRIPTION

## UF Package 24-Lead Plastic QFN (4mm × 4mm) (Reference LTC DWG # 05-08-1697)

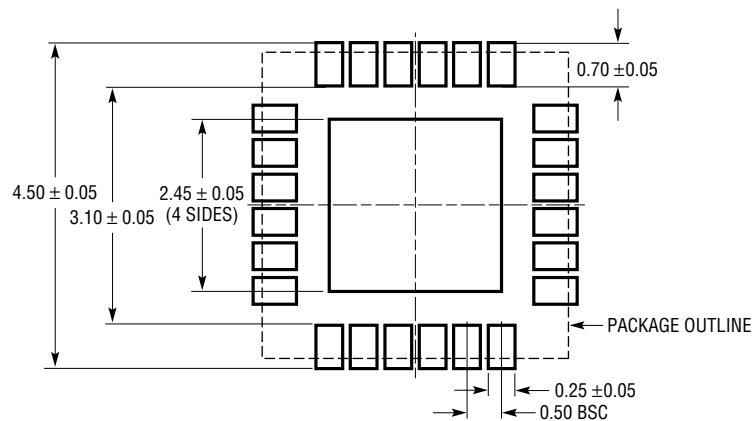

RECOMMENDED SOLDER PAD PITCH AND DIMENSIONS

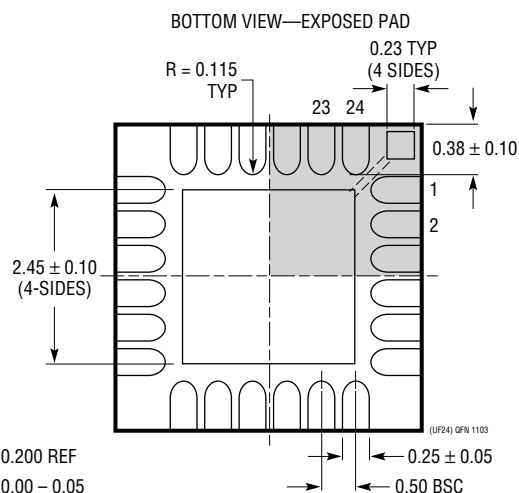
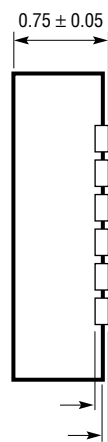
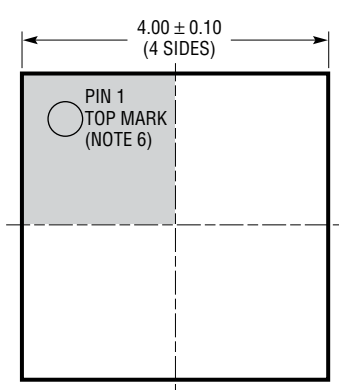

**NOTE:**

1. DRAWING PROPOSED TO BE MADE A JEDEC PACKAGE OUTLINE MO-220 VARIATION (WGGD-X)—TO BE APPROVED
2. DRAWING NOT TO SCALE
3. ALL DIMENSIONS ARE IN MILLIMETERS
4. DIMENSIONS OF EXPOSED PAD ON BOTTOM OF PACKAGE DO NOT INCLUDE MOLD FLASH. MOLD FLASH, IF PRESENT, SHALL NOT EXCEED 0.15mm ON ANY SIDE, IF PRESENT
5. EXPOSED PAD SHALL BE SOLDER PLATED
6. SHADED AREA IS ONLY A REFERENCE FOR PIN 1 LOCATION ON THE TOP AND BOTTOM OF PACKAGE

## TYPICAL APPLICATION

Quad-Output Converter Runs Off 2 AA Cells, USB or Wall Adapter

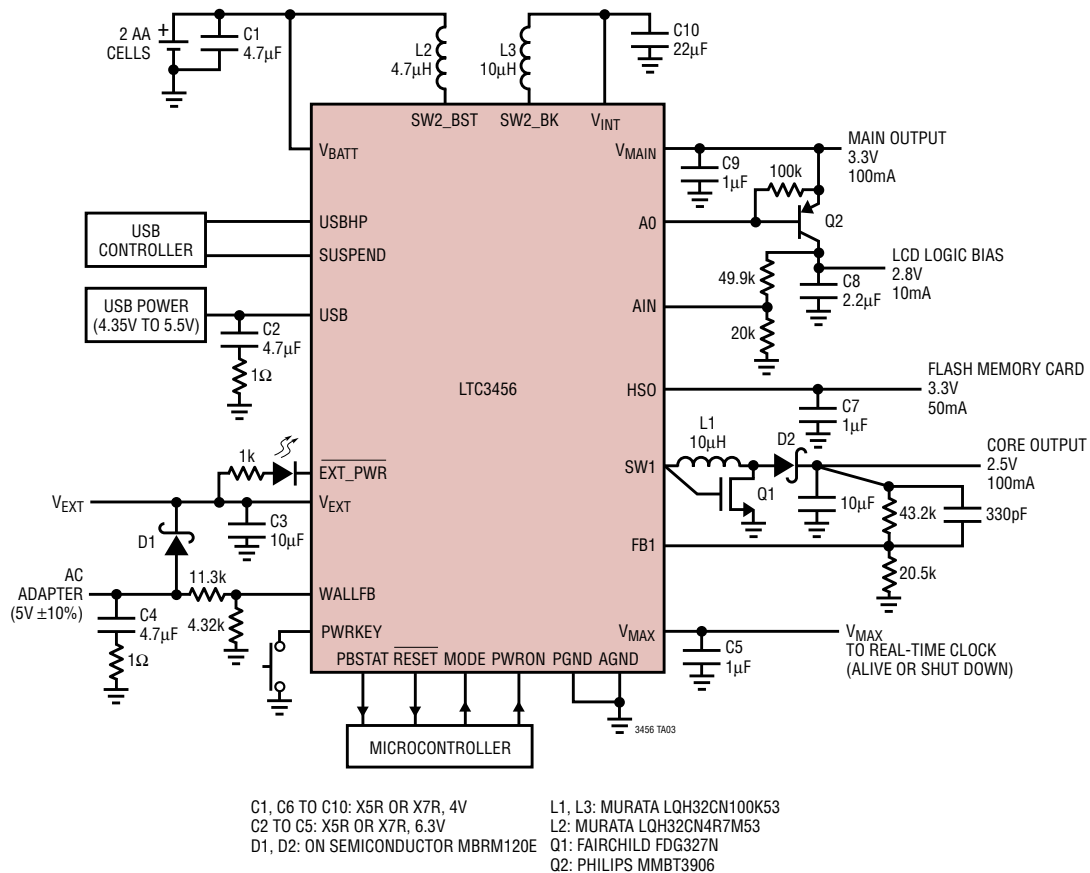



## RELATED PARTS

PART NUMBER	DESCRIPTION	COMMENTS
LT1616	500mA (I <sub>OUT</sub> ), 1.4MHz, High Efficiency Step-Down DC/DC Converter	90% Efficiency, V <sub>IN</sub> : 3.6V to 25V, V <sub>OUT(MIN)</sub> = 1.25V, I <sub>Q</sub> = 1.9mA, I <sub>SD</sub> < 1μA, ThinSOT
LTC1879	1.2A (I <sub>OUT</sub> ), 550kHz, Synchronous Step-Down DC/DC Converter	95% Efficiency, V <sub>IN</sub> : 2.7V to 10V, V <sub>OUT(MIN)</sub> = 0.8V, I <sub>Q</sub> = 15μA, I <sub>SD</sub> < 1μA, TSSOP16
LTC3405/LTC3405A	300mA (I <sub>OUT</sub> ), 1.5MHz, Synchronous Step-Down DC/DC Converter	95% Efficiency, V <sub>IN</sub> : 2.7V to 6V, V <sub>OUT(MIN)</sub> = 0.8V, I <sub>Q</sub> = 20μA, I <sub>SD</sub> < 1μA, ThinSOT
LTC3406/LTC3406B	600mA (I <sub>OUT</sub> ), 1.5MHz, Synchronous Step-Down DC/DC Converter	96% Efficiency, V <sub>IN</sub> : 2.5V to 5.5V, V <sub>OUT(MIN)</sub> = 0.6V, I <sub>Q</sub> = 20μA, I <sub>SD</sub> < 1μA, ThinSOT
LTC3407	Dual 600mA (I <sub>OUT</sub> ), 1.5MHz, Synchronous Step-Down DC/DC Converter	96% Efficiency, V <sub>IN</sub> : 2.5V to 5.5V, V <sub>OUT(MIN)</sub> = 0.6V, I <sub>Q</sub> = 40μA, I <sub>SD</sub> < 1μA, MS10E
LTC3412	2.5A (I <sub>OUT</sub> ), 4MHz, Synchronous Step-Down DC/DC Converter	95% Efficiency, V <sub>IN</sub> : 2.5V to 5.5V, V <sub>OUT(MIN)</sub> = 0.8V, I <sub>Q</sub> = 60μA, I <sub>SD</sub> < 1μA, TSSOP16E
LTC3414	4A (I <sub>OUT</sub> ), 4MHz, Synchronous Step-Down DC/DC Converter	95% Efficiency, V <sub>IN</sub> : 2.25V to 5.5V, V <sub>OUT(MIN)</sub> = 0.8V, I <sub>Q</sub> = 64μA, I <sub>SD</sub> < 1μA, TSSOP16E
LTC3440/LTC3441	600mA/1A (I <sub>OUT</sub> ), 2MHz/1MHz, Synchronous Buck-Boost DC/DC Converter	95% Efficiency, V <sub>IN</sub> : 2.5V to 5.5V, V <sub>OUT(MIN)</sub> = 2.5V, I <sub>Q</sub> = 25μA/50μA, I <sub>SD</sub> < 1μA, MS/DFN
LTC3455	Dual DC/DC Converter with USB Power Manager and Li-Ion Battery	96% Efficiency, Seamless Transition Between Inputs, I <sub>Q</sub> = 110μA, I <sub>SD</sub> < 2μA, QFN

3456fa

## Looking for pricing, stock, or lifecycle information?

Click below to explore more details on WIN SOURCE:

-  [View LTC3456EUF#PBF on WIN SOURCE](#)
-  [Linear Technology Information](#)

## Optimize Your Supply Chain with WIN SOURCE Solutions

-  Global Sourcing Solution
-  Obsolete Management
-  Cost Control Management
-  Shortage Management
-  Alternative Solution
-  Excess Inventory Management