



**THE DATASHEET OF
LTC2932IF#TRPBF**



Configurable Six Supply Monitor with Adjustable Reset Timer and Supply Tolerance

FEATURES

- Simultaneously Monitors Six Supplies
- 16 User Selectable Combinations of 5V, 3.3V, 3V, 2.5V, 1.8V, 1.5V and ± Adjustable Voltage Thresholds
- Guaranteed Threshold Accuracy: ±1.5%
- Selectable Supply Tolerances: 5%, 7.5%, 10%, 12.5% Below Monitored Voltage
- Reset Disable Pin for Margining Applications
- Low Supply Current: 52µA
- Power Supply Glitch Immunity
- Guaranteed \overline{RST} for $V_{CC} \geq 1V$
- High Temperature Operation to 125°C
- 20-Lead TSSOP Package

APPLICATIONS

- Desktop and Notebook Computers
- Multivoltage Systems
- Telecom Equipment
- Portable Battery-Powered Equipment
- Network Servers
- Automotive

DESCRIPTION

The LTC[®]2932 is a configurable supply monitor for systems with up to six supply voltages. One of 16 preset or adjustable voltage monitor combinations can be selected using an external resistive divider connected to the mode select pin. The preset voltage thresholds are digitally configurable to 5%, 7.5%, 10%, or 12.5% below the nominal operating voltage. The LTC2932 also features adjustable inputs with a 0.5V nominal threshold. All six open-drain voltage comparator outputs are connected to separate pins for individual supply monitoring.

The reset timeout period is adjustable using an external capacitor. The \overline{RST} output is guaranteed to be in the correct state for V_{CC} down to 1V and may be disabled during supply margin testing. Each status output has a weak internal pull-up and may be externally pulled up to an external voltage.

The 52µA supply current makes the LTC2932 ideal for power conscious systems and the part may be configured to monitor less than six inputs.

LT, LT, LTC and LTM are registered trademarks of Linear Technology Corporation. All other trademarks are the property of their respective owners. Protected by U.S. Patents including 6967591, 7119714, 7239251.

TYPICAL APPLICATION

Six Supply Monitor 12V (ADJ),
5V, 3.3V, 2.5V, 1.8V, 1.2V (ADJ)

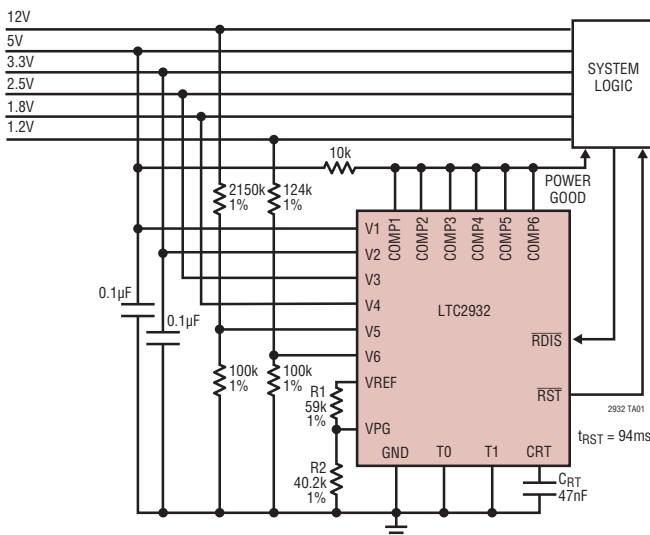

Voltage Threshold Configuration Table

| V1 (V) | V2 (V) | V3 (V) | V4 (V) | V5 (V) | V6 (V) |
|--------|--------|--------|--------|--------|--------|
| 5 | 3.3 | 2.5 | 1.8 | ADJ | ADJ |
| 5 | 3.3 | 2.5 | 1.5 | ADJ | ADJ |
| 5 | 3.3 | 2.5 | ADJ | ADJ | ADJ |
| 5 | 3.3 | 1.8 | ADJ | ADJ | ADJ |
| 5 | 3.3 | 1.8 | -ADJ | ADJ | ADJ |
| 5 | 3.3 | ADJ | ADJ | ADJ | ADJ |
| 5 | 3.3 | ADJ | -ADJ | ADJ | ADJ |
| 5 | 3 | 2.5 | ADJ | ADJ | ADJ |
| 5 | 3 | 1.8 | ADJ | ADJ | ADJ |
| 5 | 3 | ADJ | ADJ | ADJ | ADJ |
| 3.3 | 2.5 | 1.8 | 1.5 | ADJ | ADJ |
| 3.3 | 2.5 | 1.8 | ADJ | ADJ | ADJ |
| 3.3 | 2.5 | 1.8 | -ADJ | ADJ | ADJ |
| 3.3 | 2.5 | 1.5 | ADJ | ADJ | ADJ |
| 3.3 | 2.5 | ADJ | ADJ | ADJ | ADJ |
| 3.3 | 2.5 | ADJ | -ADJ | ADJ | ADJ |

2932fb

ABSOLUTE MAXIMUM RATINGS

(Notes 1, 2, 3)

| | |
|---|-----------------------------------|
| V1, V2, V3, V4, V5, V6, VPG | -0.3V to 7V |
| RST, COMP1-6, T0, T1 | -0.3V to 7V |
| CRT, VREF, RDIS | -0.3V to (V _{CC} + 0.3V) |
| Reference Load Current (I _{VREF}) | ±1mA |
| V4 Input Current (-ADJ Mode) | -1mA |
| RST, COMP1-6 Currents | ±10mA |
| Operating Temperature Range | |
| LTC2932C | 0°C to 70°C |
| LTC2932I | -40°C to 85°C |
| LTC2932H | -40°C to 125°C |
| Storage Temperature Range | -65°C to 150°C |
| Lead Temperature (Soldering, 10 sec) | 300°C |

PIN CONFIGURATION

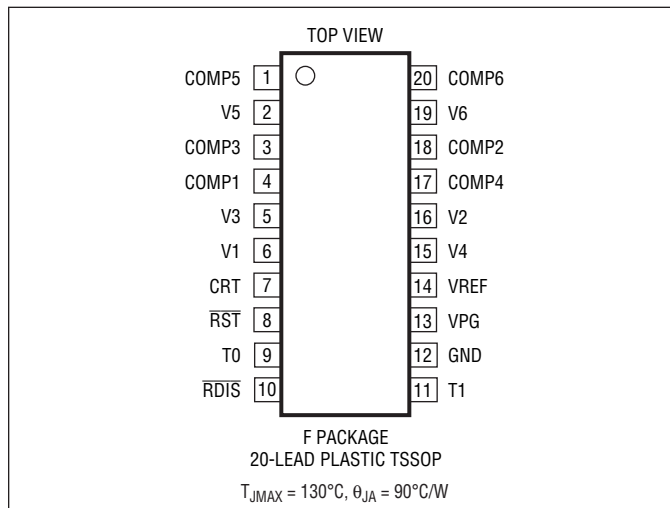

ORDER INFORMATION

| LEAD FREE FINISH | TAPE AND REEL | PART MARKING* | PACKAGE DESCRIPTION | TEMPERATURE RANGE |
|------------------|-----------------|---------------|-----------------------|-------------------|
| LTC2932F#PBF | LTC2932CF#TRPBF | LTC2932F | 20-Lead Plastic TSSOP | 0°C to 70°C |
| LTC2932F#PBF | LTC2932IF#TRPBF | LTC2932F | 20-Lead Plastic TSSOP | -40°C to 85°C |
| LTC2932F#PBF | LTC2932HF#TRPBF | LTC2932F | 20-Lead Plastic TSSOP | -40°C to 125°C |

Consult LTC Marketing for information on non-standard lead based finish parts. *Temperature grades are identified by a label on the shipping container.

For more information on lead free part marking, go to: <http://www.linear.com/leadfree/>

This product is only offered in trays. For more information go to: <http://www.linear.com/packaging/>

ELECTRICAL CHARACTERISTICS

The ● denotes the specifications which apply over the full operating temperature range, otherwise specifications are at T_A = 25°C. V_{CC} = 5V, unless otherwise specified. (Note 3)

| SYMBOL | PARAMETER | CONDITIONS | MIN | TYP | MAX | UNITS | |
|---------------------|--|---|-----|-------|-------|-------|---|
| V _{CC} | Minimum Internal Operating Voltage | RST, COMP _n in Correct Logic State | ● | | 1 | V | |
| V _{CCMINP} | Minimum Required for Mode Selection | V _{CC} Rising | ● | | 2.4 | V | |
| V _{CCMINC} | Minimum Required for Comparators | V _{CC} Falling | ● | | 2.3 | V | |
| V _{RT50} | 5V, 5% Reset Threshold 5V, 7.5% Reset Threshold 5V, 10% Reset Threshold 5V, 12.5% Reset Threshold | V1 Input Threshold | ● | 4.600 | 4.675 | 4.750 | V |
| | | | ● | 4.475 | 4.550 | 4.625 | V |
| | | | ● | 4.350 | 4.425 | 4.500 | V |
| | | | ● | 4.225 | 4.300 | 4.375 | V |
| V _{RT33} | 3.3V, 5% Reset Threshold 3.3V, 7.5% Reset Threshold 3.3V, 10% Reset Threshold 3.3V, 12.5% Reset Threshold | V1, V2 Input Threshold | ● | 3.036 | 3.086 | 3.135 | V |
| | | | ● | 2.954 | 3.003 | 3.053 | V |
| | | | ● | 2.871 | 2.921 | 2.970 | V |
| | | | ● | 2.789 | 2.838 | 2.888 | V |
| V _{RT30} | 3V, 5% Reset Threshold 3V, 7.5% Reset Threshold 3V, 10% Reset Threshold 3V, 12.5% Reset Threshold | V2 Input Threshold | ● | 2.760 | 2.805 | 2.850 | V |
| | | | ● | 2.685 | 2.730 | 2.775 | V |
| | | | ● | 2.610 | 2.655 | 2.700 | V |
| | | | ● | 2.535 | 2.580 | 2.625 | V |

ELECTRICAL CHARACTERISTICS

The ● denotes the specifications which apply over the full operating temperature range, otherwise specifications are at $T_A = 25^\circ\text{C}$. $V_{CC} = 5\text{V}$, unless otherwise specified. (Note 3)

| SYMBOL | PARAMETER | CONDITIONS | MIN | TYP | MAX | UNITS |
|------------------|---|--|---------|-------|-----------|---------------|
| V_{RT25} | 2.5V, 5% Reset Threshold | V2, V3 Input Threshold | ● 2.300 | 2.338 | 2.375 | V |
| | 2.5V, 7.5% Reset Threshold | | ● 2.238 | 2.275 | 2.313 | V |
| | 2.5V, 10% Reset Threshold | | ● 2.175 | 2.213 | 2.250 | V |
| | 2.5V, 12.5% Reset Threshold | | ● 2.113 | 2.150 | 2.188 | V |
| V_{RT18} | 1.8V, 5% Reset Threshold | V3, V4 Input Threshold | ● 1.656 | 1.683 | 1.710 | V |
| | 1.8V, 7.5% Reset Threshold | | ● 1.611 | 1.638 | 1.665 | V |
| | 1.8V, 10% Reset Threshold | | ● 1.566 | 1.593 | 1.620 | V |
| | 1.8V, 12.5% Reset Threshold | | ● 1.521 | 1.548 | 1.575 | V |
| V_{RT15} | 1.5V, 5% Reset Threshold | V3, V4 Input Threshold | ● 1.380 | 1.403 | 1.425 | V |
| | 1.5V, 7.5% Reset Threshold | | ● 1.343 | 1.365 | 1.388 | V |
| | 1.5V, 10% Reset Threshold | | ● 1.305 | 1.328 | 1.350 | V |
| | 1.5V, 12.5% Reset Threshold | | ● 1.268 | 1.290 | 1.313 | V |
| V_{RTA} | ADJ, 5% Reset Threshold | V3, V4, V5, V6 Input Threshold | ● 492.5 | 500.0 | 507.5 | mV |
| | ADJ, 7.5% Reset Threshold | | ● 479.4 | 486.6 | 494 | mV |
| | ADJ, 10% Reset Threshold | | ● 466.3 | 473.3 | 480.4 | mV |
| | ADJ, 12.5% Reset Threshold | | ● 453.1 | 459.9 | 466.8 | mV |
| V_{RTAN} | -ADJ Reset Threshold | V4 Input Threshold | ● -18 | 0 | 18 | mV |
| V_{REF} | Reference Voltage | $V_{CC} \geq 2.3\text{V}$, $I_{VREF} = \pm 1\text{mA}$, $C_{REF} \leq 1000\text{pF}$ | ● 1.192 | 1.210 | 1.228 | V |
| | | T0 Low, T1 Low | ● 1.160 | 1.178 | 1.195 | V |
| | | T0 Low, T1 High | ● 1.128 | 1.146 | 1.163 | V |
| | | T0 High, T1 Low | ● 1.096 | 1.113 | 1.130 | V |
| | | T0 High, T1 High | ● 1.096 | 1.113 | 1.130 | V |
| V_{PG} | Mode Selection Voltage Range | $V_{CC} \geq V_{CCMINP}$ | ● 0 | | V_{REF} | V |
| I_{VPG} | VPG Input Current | $V_{PG} = V_{REF}$ | ● | | ± 20 | nA |
| I_{V1} | V1 Input Current | $V1 = 5\text{V}$, $I_{VREF} = 12\mu\text{A}$ (Note 4) | ● | 52 | 75 | μA |
| I_{V2} | V2 Input Current | $V2 = 3.3\text{V}$ | ● | 0.8 | 2 | μA |
| I_{V3} | V3 Input Current | $V3 = 2.5\text{V}$ | ● | 0.52 | 1.2 | μA |
| | | $V3 = 0.55\text{V}$ (ADJ Mode) | ● | | ± 15 | nA |
| I_{V4} | V4 Input Current | $V4 = 1.8\text{V}$ | ● | 0.34 | 0.8 | μA |
| | | $V4 = 0.55\text{V}$ (ADJ Mode) | ● | | ± 15 | nA |
| | | $V4 = -0.02\text{V}$ (-ADJ Mode) | ● | | ± 15 | nA |
| I_{V5}, I_{V6} | V5, V6 Input Current | $V5, V6 = 0.55\text{V}$ | ● | | ± 15 | nA |
| $I_{CRT(UP)}$ | CRT Pull-Up Current | $V_{CRT} = \text{GND}$ | ● -1.4 | -2 | -2.6 | μA |
| $I_{CRT(DN)}$ | CRT Pull-Down Current | $V_{CRT} = 1.3\text{V}$ | ● 10 | 20 | 30 | μA |
| I_{COMPn} | COMP _n Pull-Up Current | $V_{COMPn} = \text{GND}$ | ● -2 | -6 | -12 | μA |
| t_{RST} | Reset Timeout Period | $C_{RT} = 1500\text{pF}$ | ● 2 | 3 | 4 | ms |
| t_{UV} | V_n Undervoltage Detect to $\overline{\text{RST}}$ or COMP _n | V_n Less Than Reset Threshold by More than 1% | | 150 | | μs |
| V_{OL} | Voltage Output Low $\overline{\text{RST}}$, COMP _n | $I_{SINK} = 3\text{mA}$, $V_{CC} = 3\text{V}$ | ● | 0.15 | 0.4 | V |
| | | $I_{SINK} = 100\mu\text{A}$, $V_{CC} = 1\text{V}$ | ● | 0.05 | 0.3 | V |
| V_{OH} | Voltage Output High $\overline{\text{RST}}$, COMP _n (Note 5) | $I_{SOURCE} = -1\mu\text{A}$ | ● | V2-1 | | V |

ELECTRICAL CHARACTERISTICS

The ● denotes the specifications which apply over the full operating temperature range, otherwise specifications are at $T_A = 25^\circ\text{C}$. $V_{CC} = 5\text{V}$, unless otherwise specified. (Note 3)

| SYMBOL | PARAMETER | CONDITIONS | MIN | TYP | MAX | UNITS | |
|------------------------------------|---|--|-----|-------------|-------------|---------------|---------------|
| Digital Inputs T0, T1, RDIS | | | | | | | |
| V_{IL} | T0, T1 Low Level Input Voltage | $V_{CC} = 3.3\text{V to } 5.5\text{V}$ | ● | | $0.3V_{CC}$ | V | |
| V_{IH} | T0, T1 High Level Input Voltage | $V_{CC} = 3.3\text{V to } 5.5\text{V}$ | ● | $0.7V_{CC}$ | | V | |
| I_{INTOL} | T0, T1 Input Current | $T0, T1 = 2\text{V}$ | ● | ± 0.1 | ± 1 | μA | |
| V_{IL} | $\overline{\text{RDIS}}$ Input Threshold Low | $V_{CC} = 3.3\text{V to } 5.5\text{V}$ | ● | | 0.4 | V | |
| V_{IH} | $\overline{\text{RDIS}}$ Input Threshold High | $V_{CC} = 3.3\text{V to } 5.5\text{V}$ | ● | 1.6 | | V | |
| I_{RDIS} | $\overline{\text{RDIS}}$ Pull-Up Current | $V_{RDIS} = 1\text{V}$ | ● | -4 | -10 | -16 | μA |

Note 1: Stresses beyond those listed under Absolute Maximum Ratings may cause permanent damage to the device. Exposure to any Absolute Maximum Rating condition for extended periods may affect device reliability and lifetime.

Note 2: All currents into pins are positive, all voltages are referenced to GND unless otherwise noted.

Note 3: The greater of V1, V2 is the internal supply voltage (V_{CC}).

Note 4: Under static no-fault conditions, V1 will necessarily supply quiescent current. If at any time V2 is larger than V1, V2 must be capable of supplying the quiescent current, programming (transient) current and reference load current.

Note 5: The output pins $\overline{\text{RST}}$ and COMP_n have diode protected internal pull-ups to V2 of typically $6\mu\text{A}$. However, external pull-up resistors may be used when faster rise times are required or for V_{OH} voltages greater than V2.

TIMING DIAGRAM

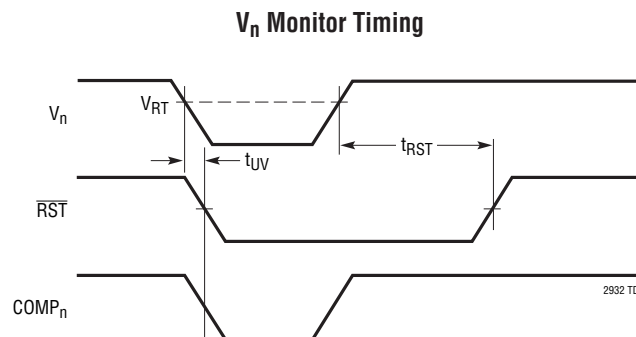

TYPICAL PERFORMANCE CHARACTERISTICS

Normalized Threshold Voltages vs Temperature

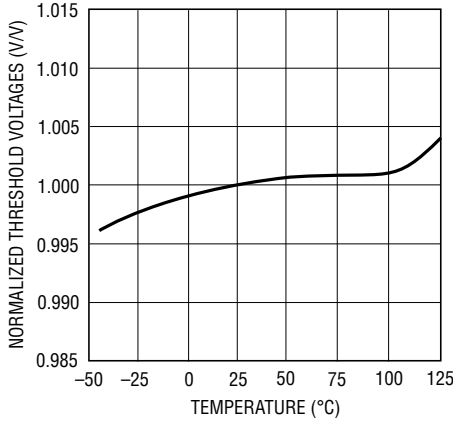

2932 G01

-ADJ Threshold Voltage vs Temperature

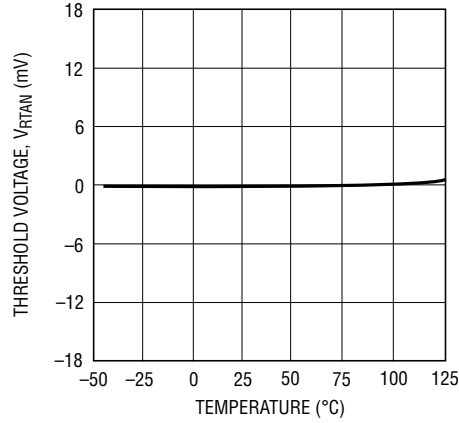

2932 G02

V_{REF} vs Temperature

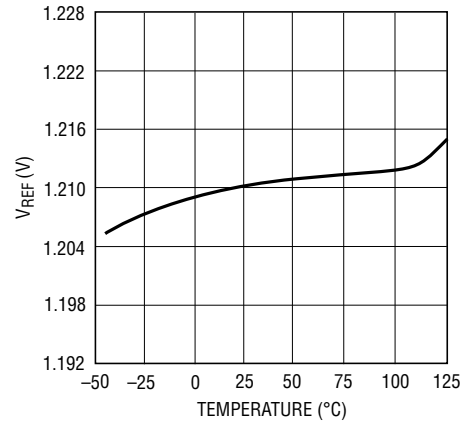

2932 G03

Supply Current vs Temperature

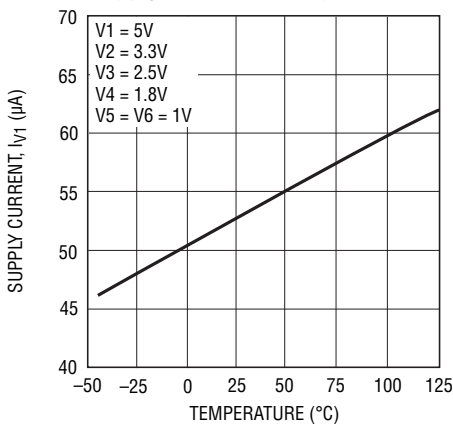

2932 G04

I(V₄) vs V₄ in Negative Adjust Mode

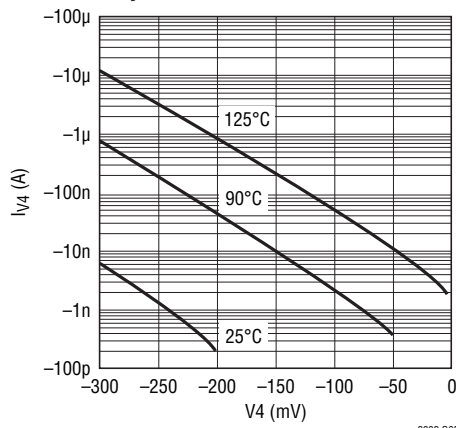

2932 G05

Transient Duration vs Comparator Overdrive (V₁, V₂)

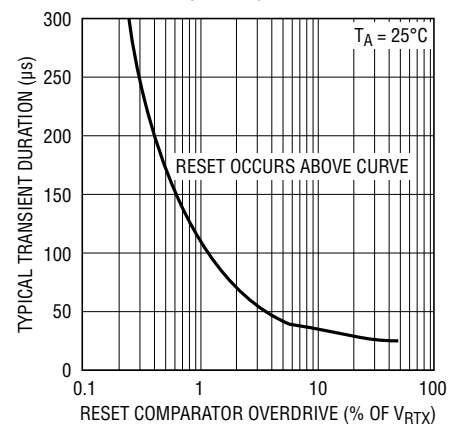

2932 G06

Transient Duration vs Comparator Overdrive (V₃, V₄, V₅, V₆)

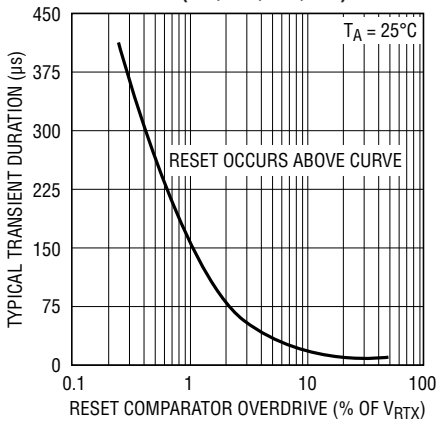

2932 G07

RST Output Voltage vs V₁, V_{PG} = GND

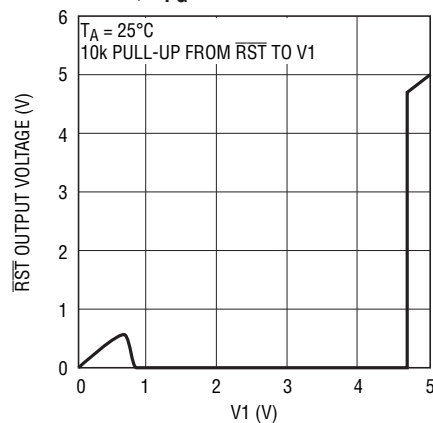

2932 G08

Reset Timeout Period vs Temperature

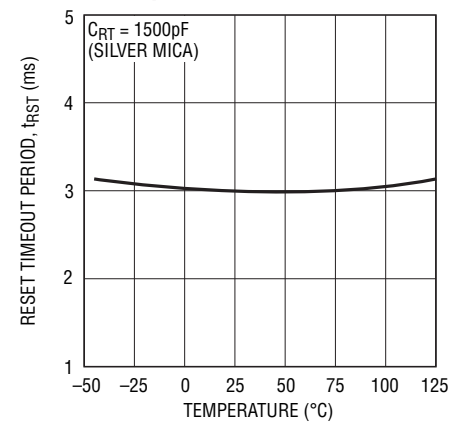

2932 G09

TYPICAL PERFORMANCE CHARACTERISTICS

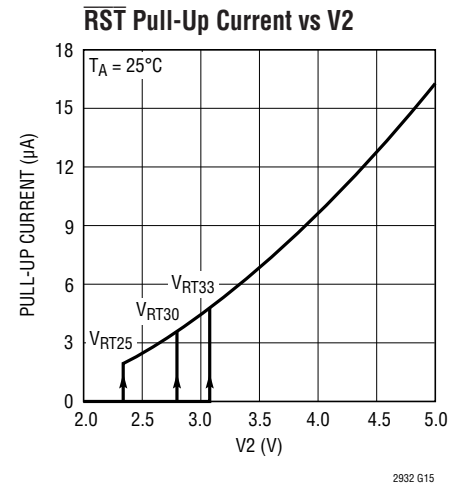
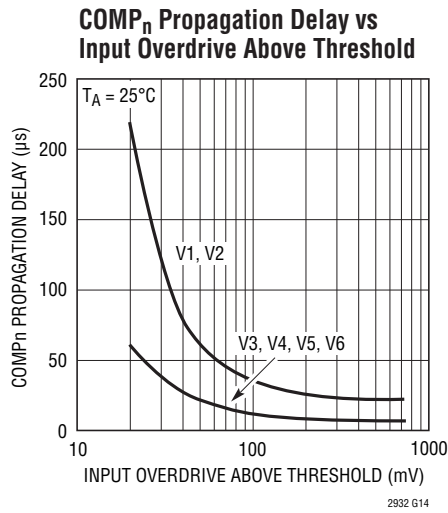
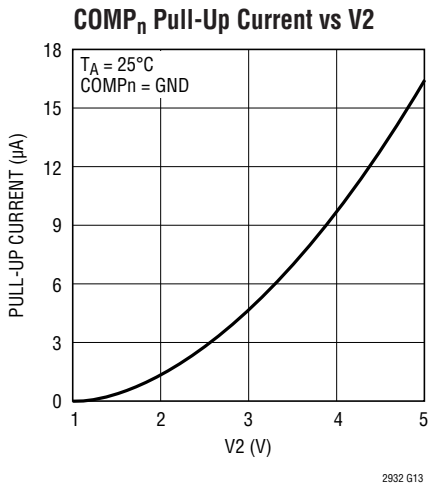
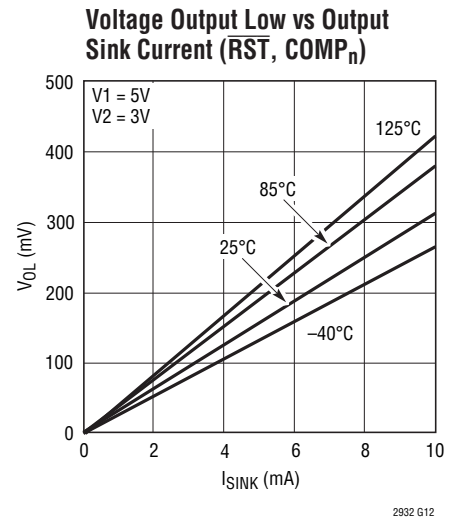
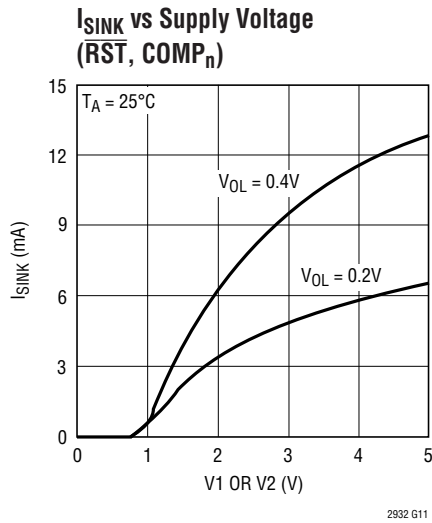
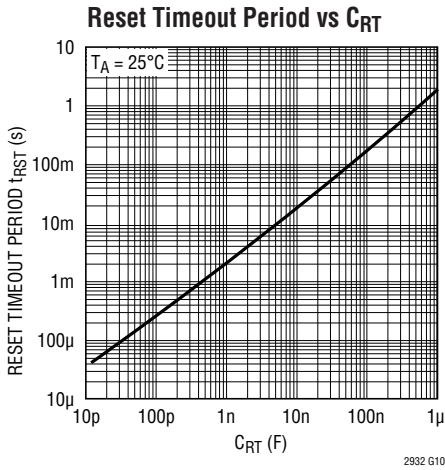

PIN FUNCTIONS

COMP5 (Pin 1): Comparator Output 5. Real-time logic output with weak 6 μ A pull-up to V2. Pulls high when V5 is above reset threshold. May be pulled greater than V2 using external pull-up. Leave open if unused.

V5 (Pin 2): Adjustable Voltage Input 5. High impedance comparator input with 0.5V typical threshold. See Applications Information for details. Tie to V1 if unused.

COMP3 (Pin 3): Comparator Output 3. Real-time logic output with weak 6 μ A pull-up to V2. Pulls high when V3 is above reset threshold. May be pulled greater than V2 using external pull-up. Leave open if unused.

COMP1 (Pin 4): Comparator Output 1. Real-time logic output with weak 6 μ A pull-up to V2. Pulls high when V1 is above reset threshold. May be pulled greater than V2 using external pull-up. Leave open if unused.

V3 (Pin 5): Voltage Input 3. Select from 2.5V, 1.8V, 1.5V, or ADJ. See Applications Information for details. Tie to V1 if unused.

V1 (Pin 6): Voltage Input 1. Select from 5V or 3.3V. See Applications Information for details. The greater of V1 or V2 is also V_{CC} for the device. Bypass this pin to ground with a 0.1 μ F (or greater) capacitor.

CRT (Pin 7): Reset Timeout Capacitor. Attach an external capacitor (C_{RT}) to GND to set a reset timeout of 2ms/nF. Leaving the pin open generates a minimum delay of approximately 25 μ s. A 47nF capacitor generates a 94ms reset delay time.

RST (Pin 8): Reset Output. Logic output with weak 6 μ A pull-up to V2. Pulls low when any voltage input is below the reset threshold and held low for the configured delay time after all voltage inputs are above threshold. May be pulled greater than V2 using external pull-up. Leave open if unused.

T0 (Pin 9): Supply Tolerance Selection Input. Used in conjunction with T1 (Pin 11). See Applications Information for tolerance selection chart (Table 2). Choose from 5%, 7.5%, 10% or 12.5%.

RDIS (Pin 10): Digital Input for $\overline{\text{RST}}$ Disable. A low input on this pin forces $\overline{\text{RST}}$ to V2 (or to the pull-up voltage). Useful for determining supply margins without issuing a reset. A weak internal pull-up allows pin to be left open for normal monitor operation.

T1 (Pin 11): Supply Tolerance Selection Input. Used in conjunction with T0 (Pin 9). See Applications Information for tolerance selection chart (Table 2). Choose from 5%, 7.5%, 10% or 12.5%.

GND (Pin 12): Ground.

VPG (Pin 13): Threshold Select Input. Connect to an external 1% resistive divider between VREF and GND to select 1 of 16 combinations and/or \pm adjustable voltage thresholds (see Table 1). Do not add capacitance on the VPG pin.

VREF (Pin 14): Buffered Reference Voltage Output. A 1.210V nominal reference used for the mode selection voltage (V_{PG}) and for the offset of negative adjustable applications. The buffered reference can source and sink up to 1mA. The reference can drive a bypass capacitor of up to 1000pF without oscillation.

V4 (Pin 15): Voltage Input 4. Select from 1.8V, 1.5V, ADJ or $-\text{ADJ}$. See Applications Information for details. Tie to V1 if unused and configured for positive voltage.

V2 (Pin 16): Voltage Input 2. Select from 3.3V, 3V or 2.5V. See Applications Information for details. The greater of V1, V2 is also V_{CC} for the device. Bypass this pin to ground with a 0.1 μ F (or greater) capacitor. All status outputs are weakly pulled up to V2.

COMP4 (Pin 17): Comparator Output 4. Real-time logic output with weak 6 μ A pull-up to V2. Pulls high when V4 is above reset threshold. May be pulled greater than V2 using external pull-up. Leave open if unused.

COMP2 (Pin 18): Comparator Output 2. Real-time logic output with weak 6 μ A pull-up to V2. Pulls high when V2 is above reset threshold. May be pulled greater than V2 using external pull-up. Leave open if unused.

PIN FUNCTIONS

V6 (Pin 19): Adjustable Voltage Input 6. High impedance comparator input with 0.5V typical threshold. See Applications Information for details. Tie to V1 if unused.

COMP6 (Pin 20): Comparator Output 6. Real-time logic output with weak 6 μ A pull-up to V2. Pulls high when V6 is above reset threshold. May be pulled greater than V2 using external pull-up. Leave open if unused.

BLOCK DIAGRAM

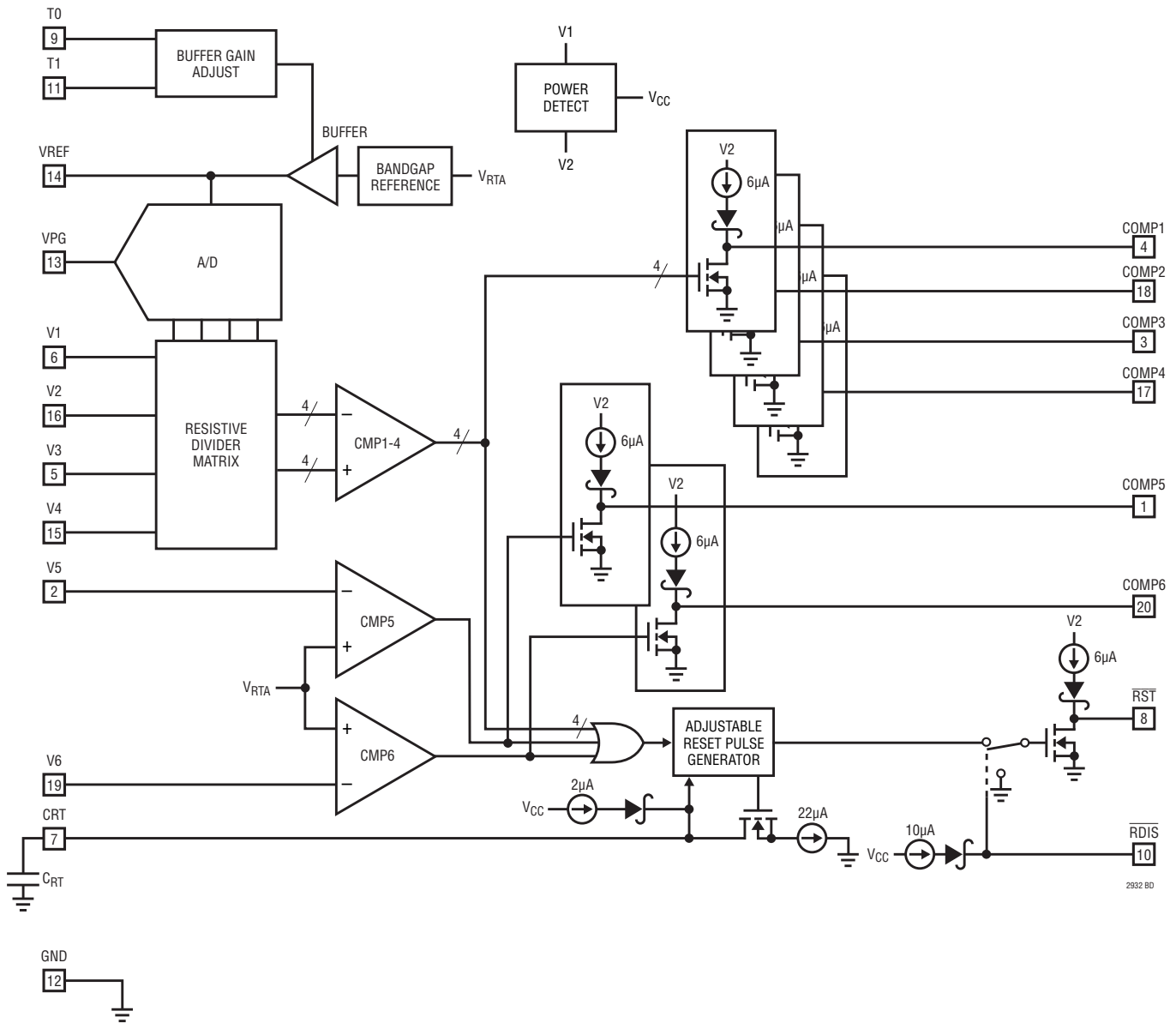

2932 BD

APPLICATIONS INFORMATION

Supply Monitoring

The LTC2932 is a low power, high accuracy configurable six supply monitoring circuit with six real-time monitor outputs, a common reset output, a reset disable function and selectable supply thresholds. An external capacitor sets the reset timeout period. An external resistive divider between VREF, VPG and GND selects 1 of 16 possible input voltage monitor combinations. All six voltage inputs must be above their predetermined thresholds for the reset not to be activated. The LTC2932 asserts the reset and comparator outputs during power-up, power-down and brownout conditions on any one of the voltage inputs.

Power-Up

The greater of V1 and V2 serves as the internal supply voltage (V_{CC}). On power-up, V_{CC} powers the drive circuits for the \overline{RST} pin. This ensures that the \overline{RST} output will be low as soon as either V1 or V2 reaches 1V. The \overline{RST} output remains low until the part is configured. Once the voltage thresholds are set, if any of the supply monitor inputs is below its configured threshold, \overline{RST} will be a logic low. Once all the monitor inputs rise above their thresholds, an internal timer is started and \overline{RST} is released after the delay time. If $V_{CC} < (V3 - 1.0V)$ and $V_{CC} < 2.4V$, the V3 input impedance will be low (10k Ω typical).

Threshold Accuracy

Consider a 5V system with $\pm 5\%$ tolerance. The 5V supply may vary between 4.75V to 5.25V. System ICs powered by this supply must operate reliably within this band (and a little more as explained below). A perfectly accurate supervisor for this supply generates a reset at exactly 4.75V, however no supervisor is this perfect. The actual reset threshold of a supervisor varies over a specified band; the LTC2932 varies $\pm 1.5\%$ around its nominal threshold voltage (see Figure 1) over temperature.

The reset threshold band and the power supply tolerance bands should not overlap. This prevents false or nuisance resets when the power supply is actually within its specified tolerance band.

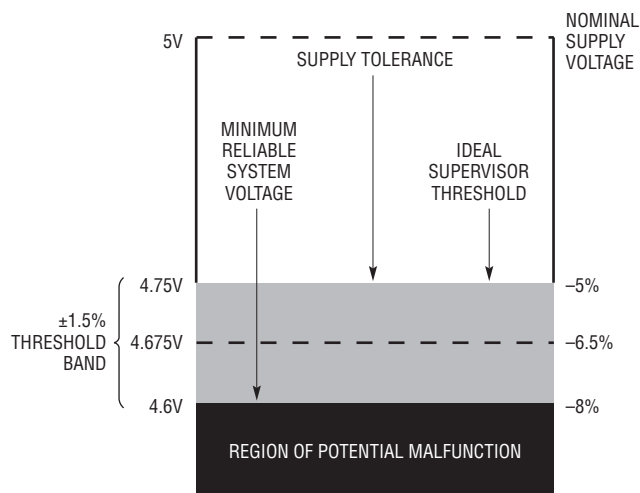

Figure 1. 1.5% Threshold Accuracy Improves System Reliability

The LTC2932 has a $\pm 1.5\%$ reset threshold accuracy, so a “5%” threshold is typically set to 6.5% below the nominal input voltage. Therefore, a typical 5V, “5%” threshold is 4.675V. The threshold is guaranteed to lie in the band between 4.750V and 4.600V over temperature. The powered system must work reliably down to the low end of the threshold band, or risk malfunction before a reset signal is properly issued.

A less accurate supervisor increases the required system voltage margin and increases the probability of system malfunction. The LTC2932’s $\pm 1.5\%$ specification improves the reliability of the system over supervisors with wider threshold tolerances.

Monitor Configuration and Tolerance Selection

Select the LTC2932 input voltage combination by placing the recommended resistive divider from VREF to GND and connecting the tap point to VPG, as shown in Figure 2. Table 1 offers recommended 1% resistor values for each of the 16 modes. The last column in Table 1 specifies optimum V_{PG}/V_{REF} ratios (± 0.01), when configuring with a ratiometric DAC.

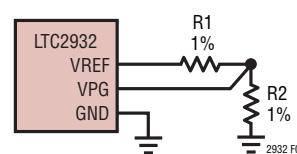

Figure 2. Mode Selection

APPLICATIONS INFORMATION

Table 1. Voltage Threshold Modes*

| MODE | V1 (V) | V2 (V) | V3 (V) | V4 (V) | R1 (k Ω) | R2 (k Ω) | $\frac{V_{PG}}{V_{REF}}$ |
|------|--------|--------|--------|--------|------------------|------------------|--------------------------|
| 0 | 5 | 3.3 | ADJ | ADJ | Open | Short | 0.000 |
| 1 | 5 | 3.3 | ADJ | -ADJ | 93.1 | 9.53 | 0.094 |
| 2 | 3.3 | 2.5 | ADJ | ADJ | 86.6 | 16.2 | 0.156 |
| 3 | 3.3 | 2.5 | ADJ | -ADJ | 78.7 | 22.1 | 0.219 |
| 4 | 3.3 | 2.5 | 1.5 | ADJ | 71.5 | 28 | 0.281 |
| 5 | 5 | 3.3 | 2.5 | ADJ | 66.5 | 34.8 | 0.344 |
| 6 | 5 | 3.3 | 2.5 | 1.8 | 59 | 40.2 | 0.406 |
| 7 | 5 | 3.3 | 2.5 | 1.5 | 53.6 | 47.5 | 0.469 |
| 8 | 5 | 3 | 2.5 | ADJ | 47.5 | 53.6 | 0.531 |
| 9 | 5 | 3 | ADJ | ADJ | 40.2 | 59 | 0.594 |
| 10 | 3.3 | 2.5 | 1.8 | 1.5 | 34.8 | 66.5 | 0.656 |
| 11 | 3.3 | 2.5 | 1.8 | ADJ | 28 | 71.5 | 0.719 |
| 12 | 3.3 | 2.5 | 1.8 | -ADJ | 22.1 | 78.7 | 0.781 |
| 13 | 5 | 3.3 | 1.8 | -ADJ | 16.2 | 86.6 | 0.844 |
| 14 | 5 | 3.3 | 1.8 | ADJ | 9.53 | 93.1 | 0.906 |
| 15 | 5 | 3 | 1.8 | ADJ | Short | Open | 1 |

*V5 and V6 are always adjustable (ADJ).

At power-up, once V1 or V2 reaches 2.4V, the monitor enters a setup period of approximately 150 μ s. During the setup time, the voltage on the VPG pin is sampled and the monitor is configured to the desired input combination. The comparators are enabled and supply monitoring begins. Do not add capacitance to the VPG pin.

The two supply tolerance inputs, T0 and T1, configure the global supply tolerance. Larger tolerances provide more headroom by lowering the trip thresholds. Table 2 lists the input combinations for each of the tolerance modes.

Table 2. Tolerance Selection

| T0 | T1 | TOLERANCE (%) | V _{REF} (V) |
|------|------|---------------|----------------------|
| Low | Low | 5 | 1.210 |
| Low | High | 7.5 | 1.178 |
| High | Low | 10 | 1.146 |
| High | High | 12.5 | 1.113 |

Table 3. Suggested 1% Resistor Values for the ADJ Inputs

| V _{SUPPLY} (V) | V _{TRIP} (V) | R3 (k Ω) | R4 (k Ω) |
|-------------------------|-----------------------|------------------|------------------|
| 12 | 11.25 | 2150 | 100 |
| 10 | 9.4 | 1780 | 100 |
| 8 | 7.5 | 1400 | 100 |
| 7.5 | 7 | 1300 | 100 |
| 6 | 5.6 | 1020 | 100 |
| 5 | 4.725 | 845 | 100 |
| 3.3 | 3.055 | 511 | 100 |
| 3 | 2.82 | 464 | 100 |
| 2.5 | 2.325 | 365 | 100 |
| 1.8 | 1.685 | 237 | 100 |
| 1.5 | 1.410 | 182 | 100 |
| 1.2 | 1.120 | 124 | 100 |
| 1 | 0.933 | 86.6 | 100 |
| 0.9 | 0.840 | 68.1 | 100 |

*See Figure 3.

Table 4. Suggested 1% Resistor Values for the -ADJ Inputs

| V _{SUPPLY} (V) | V _{TRIP} (V) | R3 (k Ω) | R4 (k Ω) |
|-------------------------|-----------------------|------------------|------------------|
| -2 | -1.87 | 187 | 121 |
| -5 | -4.64 | 464 | 121 |
| -5.2 | -4.87 | 487 | 121 |
| -10 | -9.31 | 931 | 121 |
| -12 | -11.30 | 1130 | 121 |

*See Figure 4.

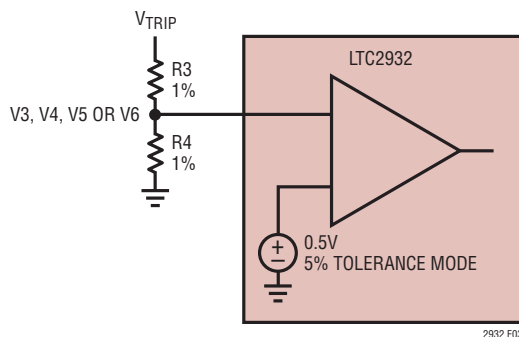

Figure 3. Setting the Positive Adjustable Trip Point

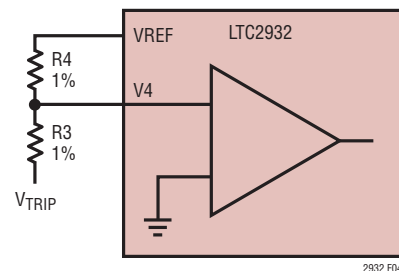

Figure 4. Setting the Negative Adjustable Trip Point

APPLICATIONS INFORMATION

Using the Adjustable Thresholds

The reference inputs on the V3 and/or V4 comparators are set to 0.5V when the positive adjustable modes are selected (Figure 3). The reference inputs on the V5 and V6 comparators are always set to 0.5V. The tap point on an external resistive divider, connected between the positive voltage being sensed and ground, is connected to the high impedance, adjustable inputs (V3, V4, V5, V6). Calculate the trip voltage from:

$$V_{\text{TRIP}} = 0.5V \cdot \left(1 + \frac{R3}{R4}\right)$$

In the negative adjustable mode, the reference level on the V4 comparator is connected to ground (Figure 4). The tap point on an external resistive divider, connected between the negative voltage being sensed and the VREF pin, is connected to the high impedance adjustable input (V4). VREF provides the necessary level shift required to operate at ground. The negative trip voltage is calculated from:

$$V_{\text{TRIP}} = -V_{\text{REF}} \cdot \frac{R3}{R4}; V_{\text{REF}} = 1.210V \text{ Nominal}$$

T0, T1 Low (5% Tolerance Mode)

Once the resistor divider is set in the 5% tolerance mode, there is no need to change the divider for the other tolerance modes (7.5%, 10%, 12.5%) because VREF is scaled accordingly, moving the trip point in -2.5% increments.

In a negative adjustable application, the minimum value for R4 is limited by the sourcing capability of VREF ($\pm 1\text{mA}$). With no other load on VREF, R4 (minimum) is:

$$\frac{1.210V}{1\text{mA}} = 1.210\text{k}\Omega$$

Tables 3 and 4 offer suggested 1% resistor values for various positive and negative supply adjustable applications assuming 5% monitor thresholds.

Although all six supply monitor comparators have built-in glitch immunity, bypass capacitors on V1 and V2 are recommended because the greater of V1 or V2 is also the VCC for the device. Filter capacitors on the V3, V4, V5 and V6 inputs are allowed.

Power-Down

On power-down, once any of the monitor inputs drops below its threshold, $\overline{\text{RST}}$ is held at a logic low. A logic low of 0.4V is guaranteed until both V1 and V2 drop below 1V. If the bandgap reference becomes invalid ($V_{\text{CC}} < 2V$ typical), the LTC2932 will enter the 150 μs setup period when VCC rises above 2.4V (max).

Selecting the Reset Timing Capacitor

The reset timeout period is adjustable in order to accommodate a variety of microprocessor applications. The reset timeout period, t_{RST} , is adjusted by connecting a capacitor, CRT, between the CRT pin and ground. The value of this capacitor is determined by:

$$C_{\text{RT}} = \frac{t_{\text{RST}}}{2\text{M}\Omega} = 500[\text{pF} / \text{ms}] \cdot t_{\text{RST}}$$

Leaving the CRT pin unconnected generates a minimum reset timeout of approximately 25 μs . Maximum reset timeout is limited by the largest available low leakage capacitor. The accuracy of the timeout period is affected by capacitor leakage (the nominal charging current is 2 μA) and capacitor tolerance. A low leakage ceramic capacitor is recommended.

Reset Disable

Under conventional operation, $\overline{\text{RST}}$ and COMP_n will go low when V_n is below its threshold. At any time, the $\overline{\text{RDIS}}$ pin can be pulled low, overriding the reset operation and forcing the $\overline{\text{RST}}$ pin high. This feature is useful when determining supply margins under processor control since the reset command will not be invoked. The $\overline{\text{RDIS}}$ pin is connected to a weak internal pull-up to VCC (10 μA typical), allowing the pin to be left open if unused.

APPLICATIONS INFORMATION

Six Supply Monitor with Hysteresis

The LTC2932 monitors six supply voltages in Figure 5 and is configured to mode 6 (see Table 1). Supply tolerance inputs T0 and T1 are tied to $\overline{\text{RST}}$. As the LTC2932 powers up, $\overline{\text{RST}}$ is low, which keeps the tolerance at 5%. After all six inputs exceed their 5% threshold voltages, $\overline{\text{RST}}$ pulls high. This changes the supply tolerance to 12.5%. If any of the input voltages drop below the 12.5% threshold level, reset is asserted. The push button on V6 also allows for a manual reset when pressed.

Five Supply Power-up Sequencer

In Figure 6, the LTC2932's real-time COMP outputs are used to enable DC/DC converters sequentially. The system is powered by a 12V source.

The system is started when the push-button is pressed and the LTC2950-1 brings the RUN pin of the LTM4600 high. Subsequently, the LTM4600 generates a 5V output which applies power to each of the 4 DC/DC converters.

The LTC2932 is configured to mode 13 and a 12.5% threshold (see Tables 1 and 2). When the threshold is reached on V1, COMP1 pulls high. COMP1 then enables the 3.3V converter first. When the threshold is reached on V2, COMP2 pulls high and enables the 1.8V converter next. When all the converters have been enabled and are good, COMP5 pulls high. $\overline{\text{RST}}$ pulls high 9.4ms after COMP5. Figure 7 shows the power-up sequence of the five supplies and the DONE and $\overline{\text{RST}}$ outputs.

If the $\overline{\text{KILL}}$ input on the LTC2950-1 does not receive a logic high from the $\overline{\text{RST}}$ output within 512ms of initial power-up, EN pulls low and the LTM4600 is powered down.

In the event that the external 12V supply drops below 9.6V, COMP6 and $\overline{\text{RST}}$ pull low. The LTC2950-1 then receives a logic low on the $\overline{\text{KILL}}$ input, which powers down the LTM4600 and the sequencing circuit.

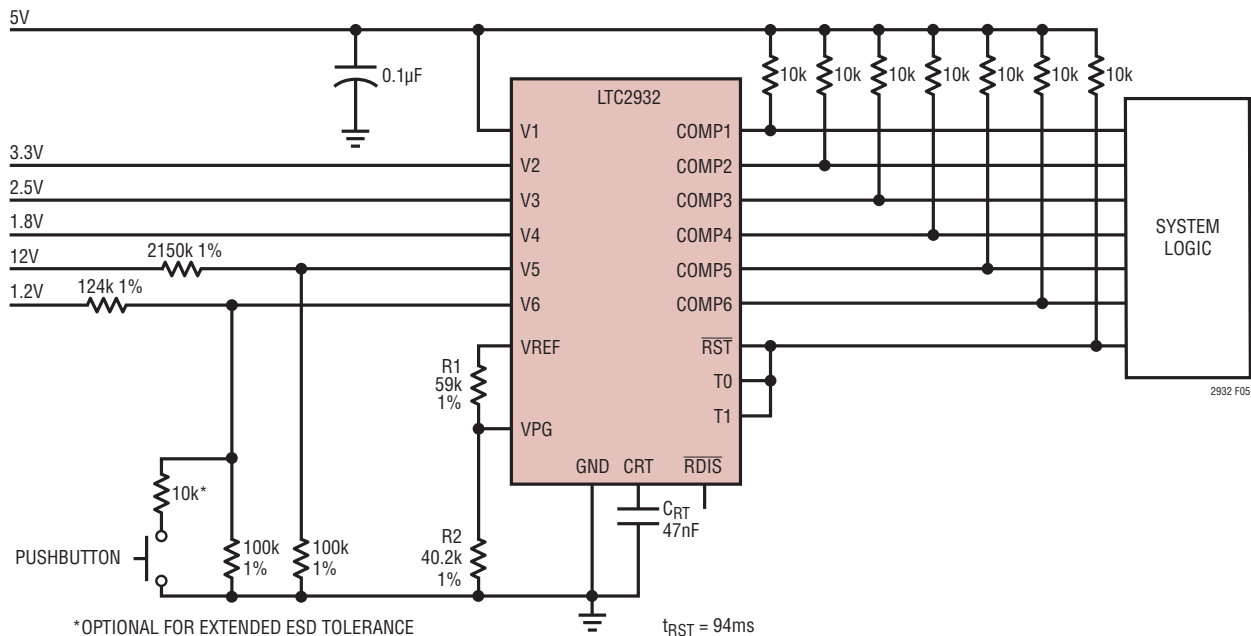

Figure 5. Six Supply Monitor with Hysteresis
5% Tolerance (Supplies Rising)
12.5% Tolerance (After RST Goes High)

APPLICATIONS INFORMATION

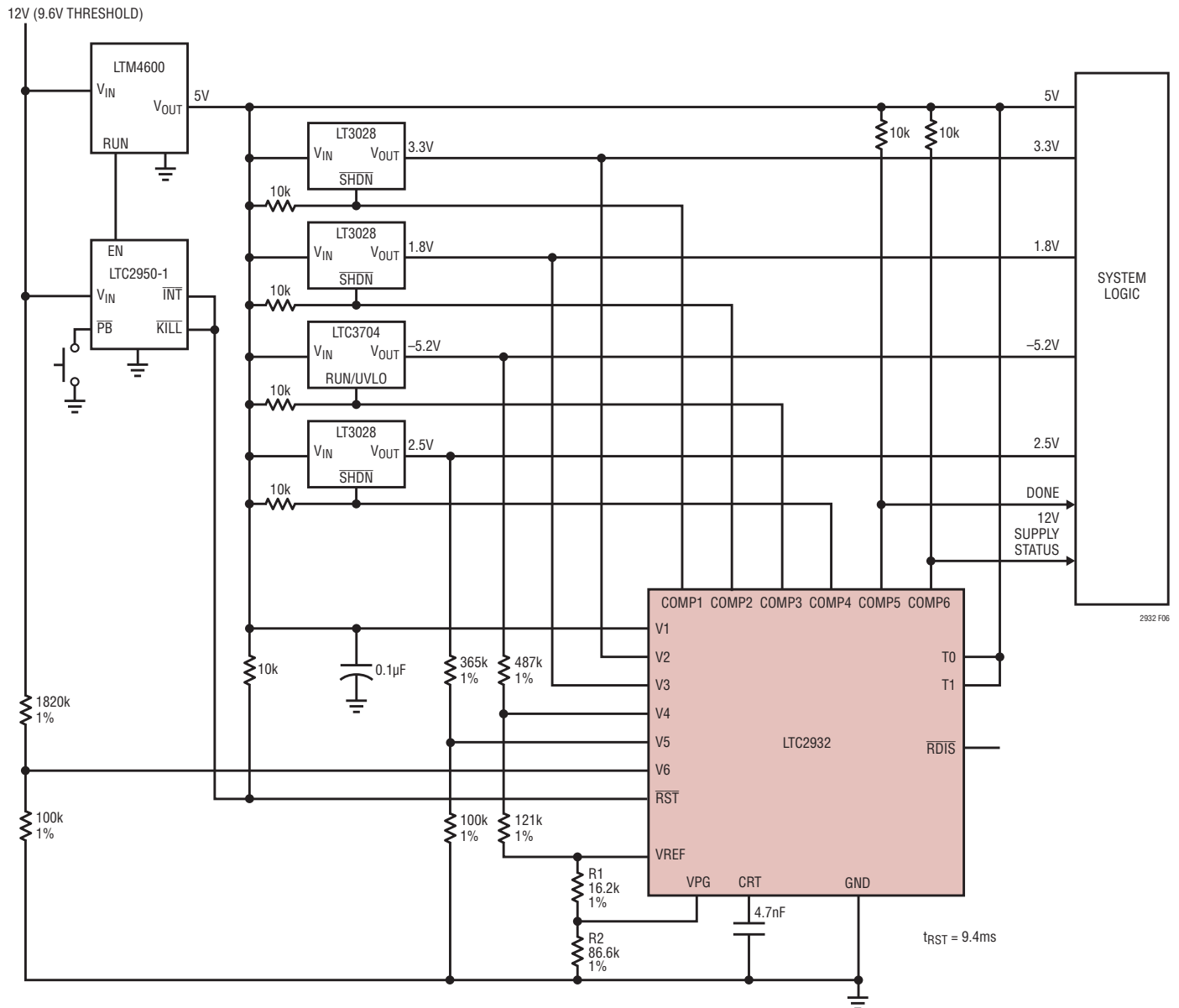

Figure 6. Five Supply 12.5% Tolerance Power-Up Sequencer with Pushbutton

APPLICATIONS INFORMATION

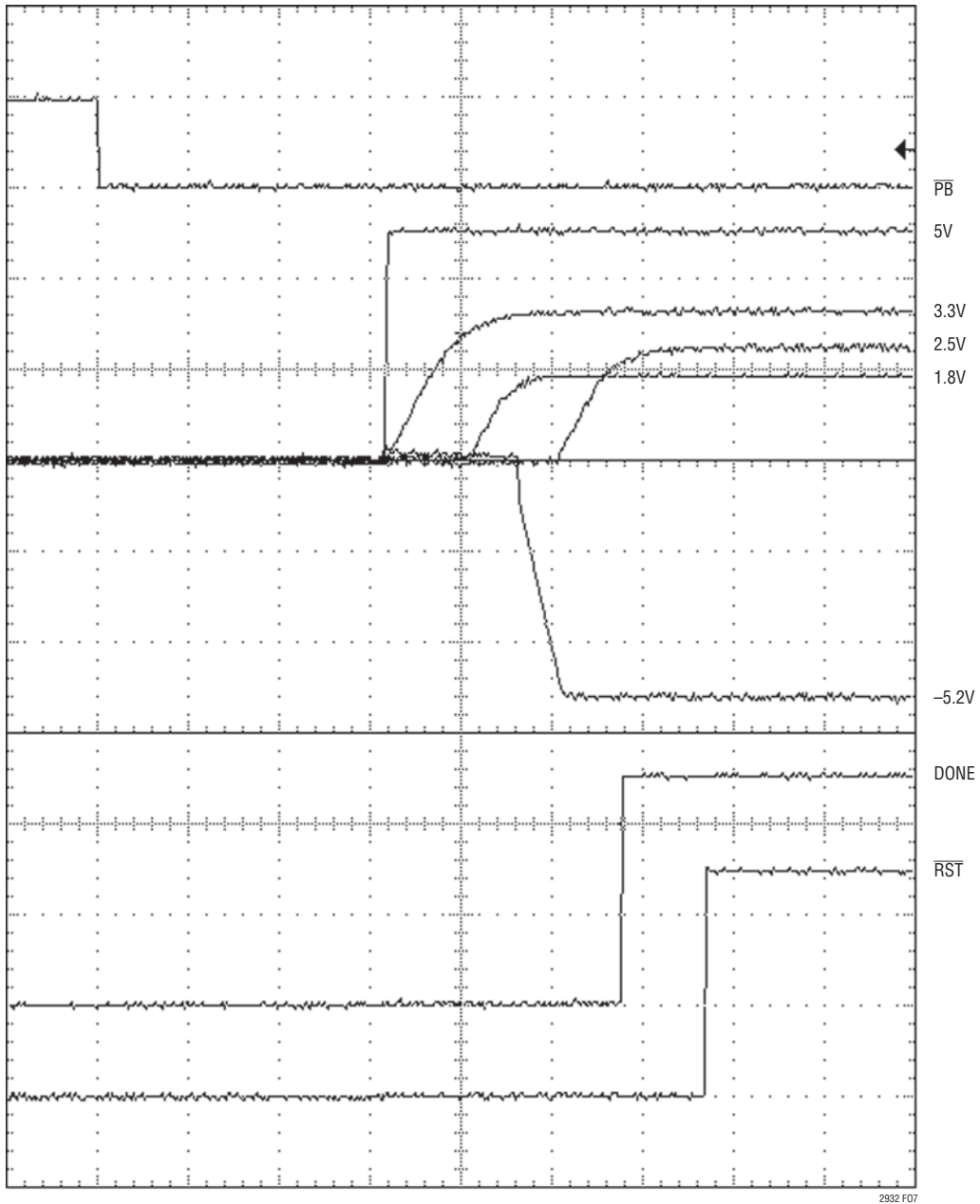
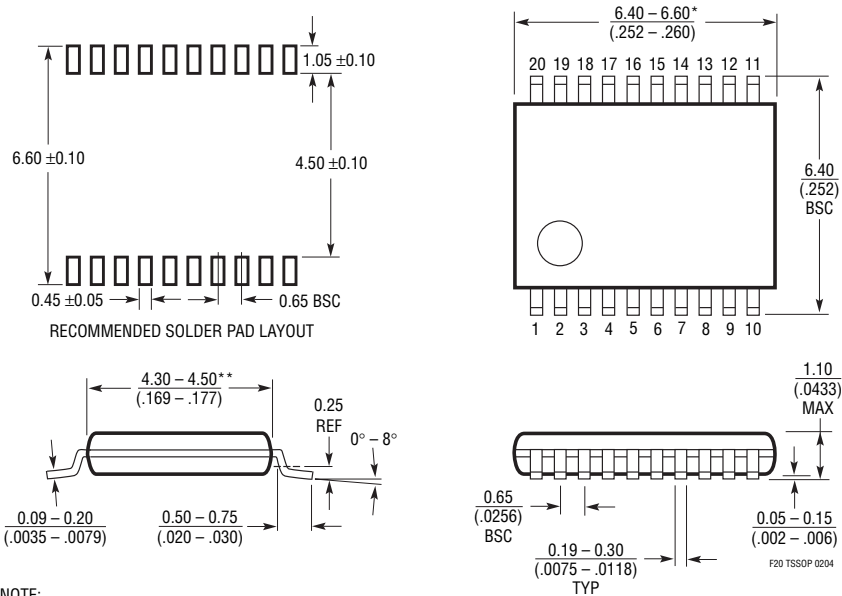

Figure 7. Five Supply Power-Up Sequencing (Based on Circuit in Figure 6)

PACKAGE DESCRIPTION

F Package 20-Lead Plastic TSSOP (4.4mm) (Reference LTC DWG # 05-08-1650)



- NOTE:
 1. CONTROLLING DIMENSION: MILLIMETERS
 2. DIMENSIONS ARE IN $\frac{\text{MILLIMETERS}}{\text{(INCHES)}}$

3. DRAWING NOT TO SCALE
 *DIMENSIONS DO NOT INCLUDE MOLD FLASH. MOLD FLASH SHALL NOT EXCEED .152mm (.006") PER SIDE
 **DIMENSIONS DO NOT INCLUDE INTERLEAD FLASH. INTERLEAD FLASH SHALL NOT EXCEED .254mm (.010") PER SIDE

TYPICAL APPLICATION

Five Supply Adjustable Threshold Monitor with LED Indicators

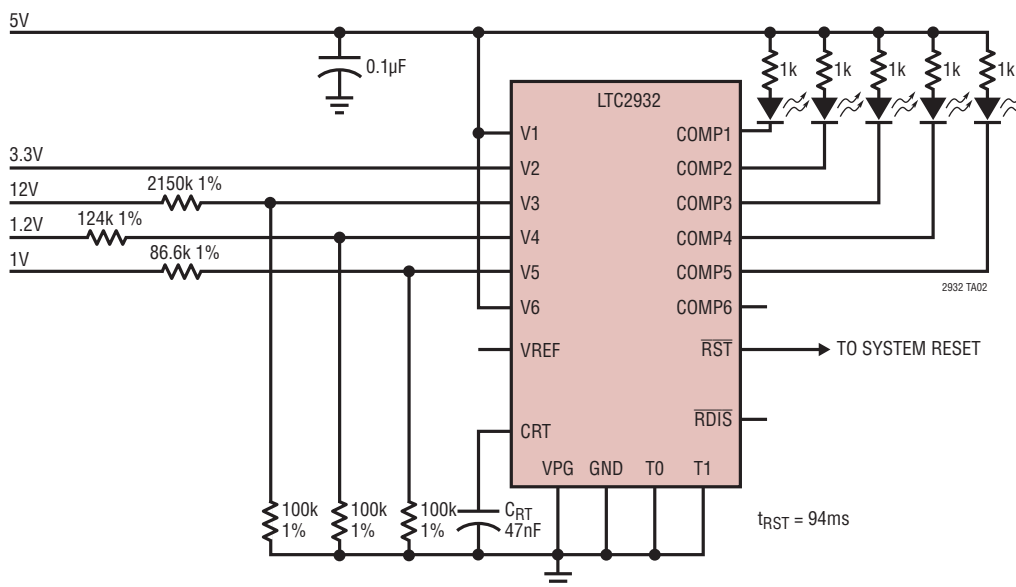

RELATED PARTS

| PART NUMBER | DESCRIPTION | COMMENTS |
|-----------------|---|---|
| LTC1326 | Micropower Triple Supply Monitor for 5V/2.5V, 3.3V and ADJ | 4.725V, 3.118V, 1V Threshold ($\pm 0.75\%$) and ADJ |
| LTC1728 | Micropower Triple Supply Monitor with Open-Drain Reset | 5-Lead SOT-23 Package |
| LTC2900 | Programmable Quad Supply Monitor | Adjustable Reset, 10-Lead MSOP and DFN Packages |
| LTC2901 | Programmable Quad Supply Monitor | Adjustable Reset and Watchdog Timer |
| LTC2902 | Programmable Quad Supply Monitor | Adjustable Reset and Tolerance (5%, 7.5%, 10%, or 12.5%) |
| LTC2903 | Precision Quad Supply Monitor | 6-Lead SOT-23 Package |
| LTC2904-LTC2907 | Three-State Programmable Precision Dual Supply Monitor | 8-Lead SOT-23 and DFN Packages |
| LTC2908 | Precision Six Supply Monitor (Four Fixed & Two Adjustable) | 8-Lead TSOT-23 and DFN Packages |
| LTC2909 | Precision Triple/Dual Input UV, OV and Negative Voltage Monitor | Shunt Regulated V_{CC} Pin, Adjustable Threshold and Reset, 8-Lead SOT-23 and DFN Packages |
| LTC2910 | Precision Octal Positive/Negative Voltage Supply Monitor | 16-Lead SSOP and 5mm \times 3mm DFN Packages, H-Grade Temperature Range |
| LTC2912-LTC2914 | Single/Dual/Quad UV and OV Voltage Monitors | Separate V_{CC} Pin, Adjustable Reset Timer, H-Grade Temperature Range |
| LTC2915-LTC2918 | Single Supply Monitor with 27 Pin-Selectable Thresholds | Manual Reset, Watchdog, TSOT-8/MSOP-10 and 3mm \times 2mm DFN Packages, H-Grade Temperature Range |
| LTC2928 | Quad Power Supply Sequencer and Supervisor | Easily Configure Power Management without Software, 36-Lead 5mm \times 7mm QFN and SSOP Packages |
| LTC2930 | Configurable Six Supply Monitor with Adjustable Reset Timer, Manual Reset | 3mm \times 3mm DFN-12 Package, H-Grade Temperature Range |
| LTC2931 | Configurable Six Supply Monitor with Adjustable Reset and Watchdog Timers | TSSOP-20 Package, H-Grade Temperature Range, Individual Supply Comparator Outputs |

Looking for pricing, stock, or lifecycle information?

Click below to explore more details on WIN SOURCE:

 [View LTC2932IF#TRPBF on WIN SOURCE](#)

 [Linear Technology](#) Information

Optimize Your Supply Chain with WIN SOURCE Solutions

-  Global Sourcing Solution
-  Obsolete Management
-  Cost Control Management
-  Shortage Management
-  Alternative Solution
-  Excess Inventory Management