



**THE DATASHEET OF
LTC222CS#PBF**



Micropower, Low Charge Injection, Quad CMOS Analog Switches with Data Latches

FEATURES

- Micropower Operation
- Single 5V or $\pm 15V$ Supply Operation
- Low Charge Injection
- Low R_{ON}
- Low Leakage
- Guaranteed Break Before Make
- Latch Resistant Design
- TLL/CMOS Compatible
- Improved Second Source for DG221/DG222
- Microprocessor Bus Compatible

KEY SPECIFICATIONS

- Supply Current $I^+ = 40\mu A, I^- = 5\mu A$ Max
- Charge Injection
 - $\pm 15V$ Supplies $\pm 25pC$ Max
 - Single 5V Supply 2pC Typ
- R_{ON} 65Ω Typ
- Signal Range $\pm 15V$

DESCRIPTION

The LTC[®]221 and LTC222 are micropower, quad CMOS analog switches which typically dissipate only 250 μ W from $\pm 15V$ supplies and 40 μ W from a single 5V supply. Onboard latches allow the LTC221 and LTC222 to interface directly to most microprocessor buses. The switches have 65 Ω typical on resistance and a very high off resistance. A break before make characteristic is inherent in these switches to prevent the shorting of two channels. The signal range is $\pm 15V$ with a supply voltage of $\pm 15V$ and 0V to 5V with a single 5V supply. The switches have special charge compensation circuitry which greatly reduces charge injection to a maximum of $\pm 25pC$ ($\pm 15V$ supplies).

The LTC221 and LTC222 are designed for applications such as microprocessor controlled programmable gain amplifiers, automatic test equipment, communication systems, and data acquisition systems. The LTC221 is normally closed and the LTC222 is normally open as shown in the Logic Table.

LT, LTC and LT are registered trademarks of Linear Technology Corporation.

TYPICAL APPLICATION

Two-Channel, 12-Bit, Self-Calibrating Data Acquisition System

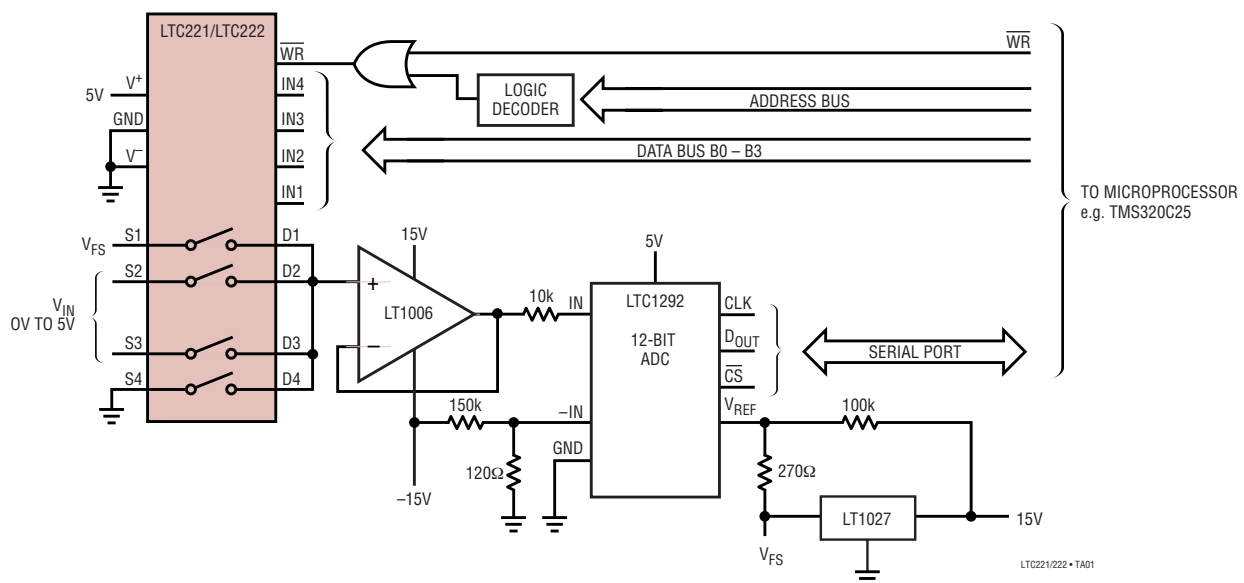

LTC221/222 • TA01

LTC221/LTC222

ABSOLUTE MAXIMUM RATINGS

(Note 1)

Voltages Referenced to V^-

V^+	44V
GND	25V
Digital Inputs, S, D (Note 2)	-2V to ($V^+ + 2V$) or 20mA, Whichever Occurs First

Current

Any Input Except S or D	30mA
Continuous S or D	20mA
Peak S or D (Pulsed at 1 ms, 10% Duty Cycle Max)	70mA

ESD Susceptibility (Note 3)

Power Dissipation (Plastic)

Power Dissipation (Ceramic)

Operating Temperature Range

LTC221C/LTC222C

LTC221M/LTC222M (OBSOLETE).....

Storage Temperature Range

Lead Temperature (Soldering, 10 sec).....

PACKAGE/ORDER INFORMATION

<p>N PACKAGE 16-LEAD PDIP $J_{MAX} = 110^{\circ}C$, $\theta_{JA} = 120^{\circ}C/W$</p> <p>S PACKAGE 16-LEAD PLASTIC SO $J_{MAX} = 110^{\circ}C$, $\theta_{JA} = 130^{\circ}C/W$</p> <p>J PACKAGE 16-LEAD CERDIP</p> <p>OBSOLETE PACKAGE Consider the N or S Package for Alternate Source</p>	ORDER PART NUMBER
	LTC221CN LTC221CS LTC222CN LTC222CS
	LTC221MJ LTC221CJ LTC222MJ LTC222CJ

Consult LTC Marketing for parts specified with wider operating temperature ranges.

LOGIC TABLE

INX	\overline{WR}	LTC221	LTC222
0	0	On	Off
1	0	Off	On
X	1	Maintain Previous State	Maintain Previous State

DIGITAL AND DC ELECTRICAL CHARACTERISTICS

The ● denotes the specifications which apply over full operating temperature range, otherwise specifications are at $T_A = 25^{\circ}C$. $V^+ = \pm 15V$, $V^- = -15V$, GND = 0V, unless noted.

PARAMETER	CONDITIONS	LTC221M/LTC222M			LTC221C/LTC222C			UNITS
		MIN	TYP	MAX	MIN	TYP	MAX	
Analog Signal Range		●		± 15		± 15		V
R_{ON}	$V_S = \pm 10V$ $I_D = 1mA$	T_{MIN}		90		90		Ω
		$25^{\circ}C$		65	90	65	90	Ω
		T_{MAX}			135		135	Ω
Off Input Leakage I_S (OFF)	$V_D = 14V$, $V_S = \pm 14V$	●		0.01	± 1	0.01	± 5	nA
		●			± 100		± 100	nA
Off Output Leakage I_D (OFF)	$V_{IN} = 2.4V$, LTC221	●		0.01	± 1	0.01	± 5	nA
	$V_{IN} = 0.8V$, LTC222	●			± 100		± 100	nA
On Channel Leakage I_D (ON)	$V_D = V_S = \pm 14V$, $V_{IN} = 2.4V$, LTC222	●		0.02	± 1	0.02	± 5	nA
	$V_{IN} = 0.8V$, LTC221	●			± 200		± 200	nA
Input High Voltage V_{INH} , $V_{\overline{WRH}}$		●	2.4			2.4		V
Input Low Voltage V_{INL} , $V_{\overline{WRL}}$		●		0.8		0.8		V
Input High or Low Current I_{INH} , I_{INL} , $I_{\overline{WRH}}$, $I_{\overline{WRL}}$	$V_{IN} = 15V$, 0V $V_{\overline{WR}} = 15V$, 0V	●		± 1		± 1		μA
C_S (OFF)			5		5			pF
C_D (OFF)			12		12			pF
C_D , C_S (ON)			30		30			pF
I^+	All Channels On or Off $V_{IN} = V_{\overline{WR}} = 0V$ or 4.0V	●	16	40	16	40		μA
		●		60		60		μA

2212fa

DIGITAL AND DC ELECTRICAL CHARACTERISTICS

The ● denotes the specifications which apply over full operating temperature range, otherwise specifications are at $T_A = 25^\circ\text{C}$. $V^+ = \pm 15\text{V}$, $V^- = -15\text{V}$, $\text{GND} = 0\text{V}$, unless noted.

PARAMETER	CONDITIONS	LTC221M/LTC222M			LTC221C/LTC222C			UNITS
		MIN	TYP	MAX	MIN	TYP	MAX	
I^-			0.1	5	0.1	5	μA	
		●		10		10		

AC ELECTRICAL CHARACTERISTICS

$V^+ = 15\text{V}$, $V^- = -15\text{V}$, $\text{GND} = 0\text{V}$, unless otherwise noted.

PARAMETER	CONDITIONS	LTC221M/LTC222M			LTC221C/LTC222C			UNITS
		MIN	TYP	MAX	MIN	TYP	MAX	
t_{ON}	$V_S = 2\text{V}$, $R_L = 1\text{k}\Omega$, $C_L = 35\text{pF}$		290	400	290	400	ns	
t_{OFF}			210	300	210	300		
t_{OPEN}		20	85		20	85	ns	
Off Isolation	$V_S = 2\text{Vp-p}$, $R_L = 1\text{k}\Omega$ $f = 100\text{kHz}$		75		75		dB	
Crosstalk			90		90			
Charge Injection O_{INJ}	$R_{\text{GEN}} = 0\Omega$, $C_L = 1000\text{pF}$, $V_{\text{GEN}} = 0$		5	± 25	8	± 25	μC	
Total Harmonic Distortion THD	$V_S = 2\text{Vp-p}$, $R_L = 10\text{k}\Omega$		0.01		0.01		%	
$t_{\text{ON}}, \overline{\text{WR}}$	$V_S = 2\text{V}$, $R_L = 1\text{k}\Omega$, $C_L = 35\text{pF}$		270	400	270	400	ns	
$t_{\text{OFF}}, \overline{\text{WR}}$			160	300	160	300		

DIGITAL AND DC ELECTRICAL CHARACTERISTICS

The ● denotes the specifications which apply over full operating temperature range, otherwise specifications are at $T_A = 25^\circ\text{C}$. $V^+ = 5\text{V}$, $V^- = \text{GND} = 0\text{V}$, unless noted.

PARAMETER	CONDITIONS	LTC221M/LTC222M			LTC221C/LTC222C			UNITS
		MIN	TYP	MAX	MIN	TYP	MAX	
Analog Signal Range		●	0	5	0	5	V	
R_{ON}	$V_S = 1.5\text{V}, 3\text{V}$ $I_D = 0.25\text{mA}$	T_{MIN}		450		520	Ω	
		25°C		280	450	280	520	Ω
		T_{MAX}			650		650	Ω
Off Input Leakage I_S (OFF)	$V_D = 4\text{V}, 1\text{V}$; $V_S = 1\text{V}, 4\text{V}$ (Note 4)		0.01	± 1	0.01	± 5	nA	
		●		± 100		± 100	nA	
Off Output Leakage I_D (OFF)			0.01	± 1	0.01	± 5	nA	
		●		± 100		± 100	nA	
On Channel Leakage I_D (ON)	$V_D = V_S = 1\text{V}, 4\text{V}$ (Note 4)		0.01	± 1	0.01	± 5	nA	
		●		± 200		± 200	nA	
Input High Voltage $V_{\text{INH}}, \overline{V_{\text{WRH}}}$		●	2.4		2.4		V	
Input Low Voltage $V_{\text{INL}}, \overline{V_{\text{WRL}}}$		●		0.8		0.8	V	
Input High or Low Current $I_{\text{INH}}, I_{\text{INL}}, \overline{I_{\text{WRH}}}, \overline{I_{\text{WRL}}}$	$V_{\text{IN}} = 5\text{V}, 0\text{V}$ $\overline{V_{\text{WR}}} = 5\text{V}, 0\text{V}$	●		± 1		± 1	μA	
C_S (OFF)			5		5		pF	
C_D (OFF)			12		12		pF	
C_D, C_S (ON)			30		30		pF	
I^+	All Channels On or Off $V_{\text{IN}} = \overline{V_{\text{WR}}} = 0\text{V}$ or 4.0V		8	20	8	20	μA	
		●		30		30	μA	

AC ELECTRICAL CHARACTERISTICS $V^+ = 5V, V^- = GND = 0V$, unless otherwise noted.

PARAMETER	CONDITIONS	LTC221M/LTC222M			LTC221C/LTC222C			UNITS
		MIN	TYP	MAX	MIN	TYP	MAX	
t_{ON}	$V_S = 2V, R_L = 1k\Omega, C_L = 35pF$		450	600		450	600	ns
t_{OFF}			190	300		190	300	ns
t_{OPEN}		100	250		100	250		ns
Off Isolation	$V_S = 2V_{P-P}, R_L = 1k\Omega$		75			75		dB
Crosstalk	$f = 100kHz$		90			90		dB
Charge Injection O_{INJ}	$R_{GEN} = 0\Omega, C_L = 1000pF, V_{GEN} = 2.5V$		2			2		pC
Total Harmonic Distortion THD	$V_S = 2V_{P-P}, R_L = 10k\Omega$		0.01			0.01		%
$t_{ON, WR}$	$V_S = 2V, R_L = 1k\Omega, C_L = 35pF$		430	600		430	600	ns
$t_{OFF, WR}$			160	300		160	300	ns

Note 1: Absolute Maximum Ratings are those values beyond which the life of a device may be impaired.

Note 2: Signals on S, D, or IN exceeding V^+ or V^- will be clamped by internal diodes. Limit forward diode current to maximum current rating.

Note 3: In-circuit ESD on the switch pins (S or D) exceeds 4kV (see test circuit).

Note 4: Leakage current with a 5V supply is guaranteed by correlation with the $\pm 15V$ leakage current.

TYPICAL PERFORMANCE CHARACTERISTICS

R_{ON} vs V_S Over Supply Voltage

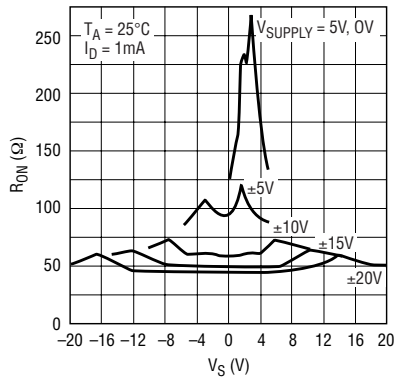

LTC221/222 • TPC01

R_{ON} vs V_S Over Temperature

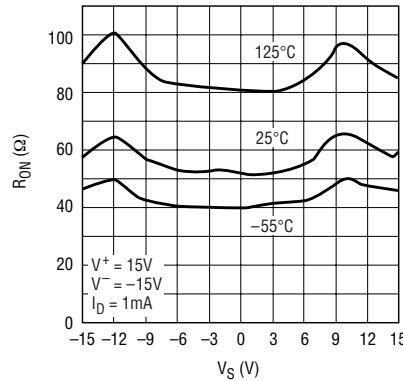

LTC221/222 • TPC02

R_{ON} vs V_S Over Temperature

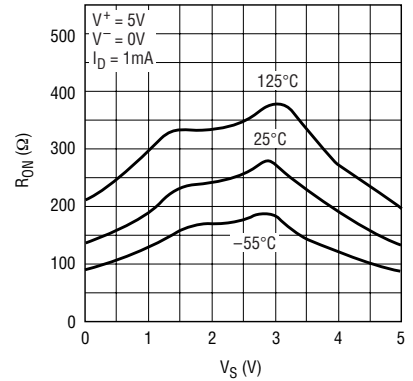

LTC221/222 • TPC03

Positive Supply Current vs Logic Input Voltage

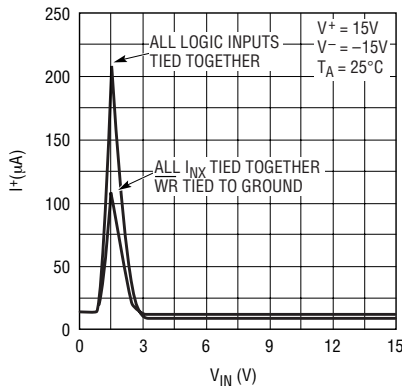

LTC221/222 • TPC04

Positive Supply Current vs Logic Input Voltage

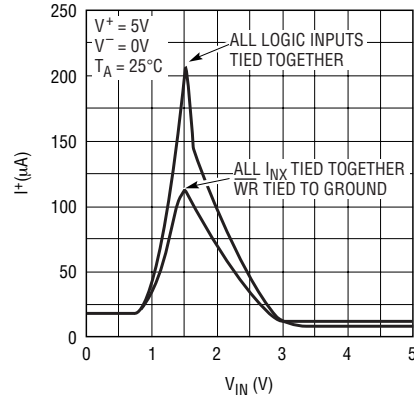

LTC221/222 • TPC05

2212fa

APPLICATIONS INFORMATION

Switching Time Test Circuit

Switch output waveform shown for $V_S = \text{constant}$ with logic input waveform as shown. Note that V_S may be (+) or (-) as per switching time test circuit. V_O is the steady

state output switch on. Feedthrough via gate capacitance may result in spikes at leading and trailing edge of output waveform.

Switching Time Test Circuit

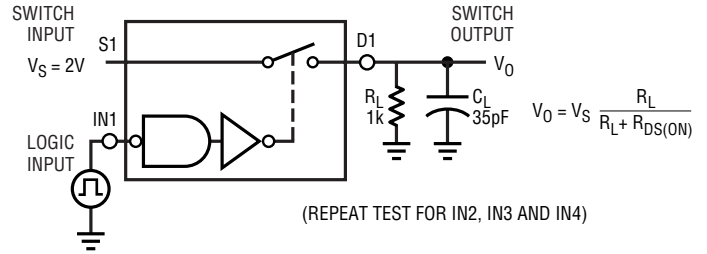
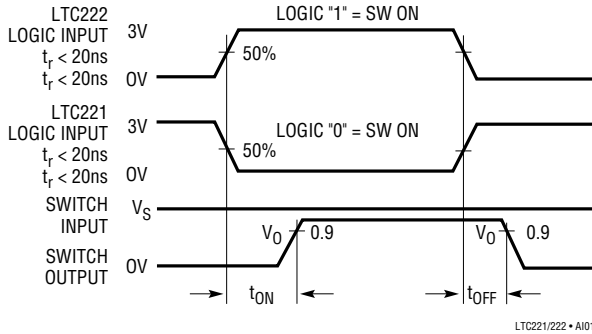

LTC221/222 • AI02

Charge Injection Test Circuit

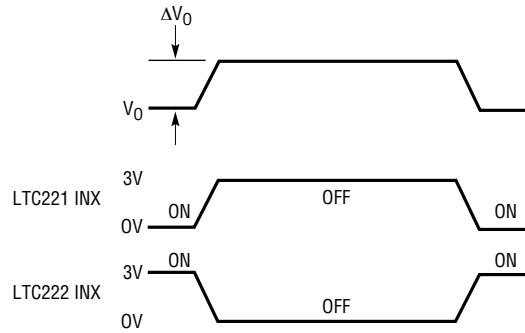
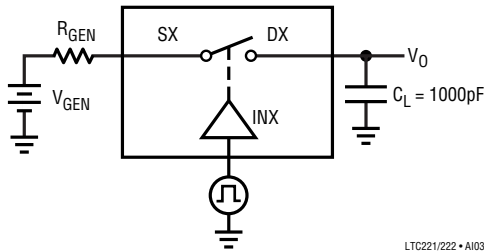

ΔV_O IS THE MEASURED VOLTAGE ERROR DUE TO CHARGE INJECTION. THE ERROR VOLTAGE IN COULOMBS IS $\Delta Q = V_L \cdot \Delta V_O$

LTC221/222 • AI04

OIRR-Off Isolation Test Circuit

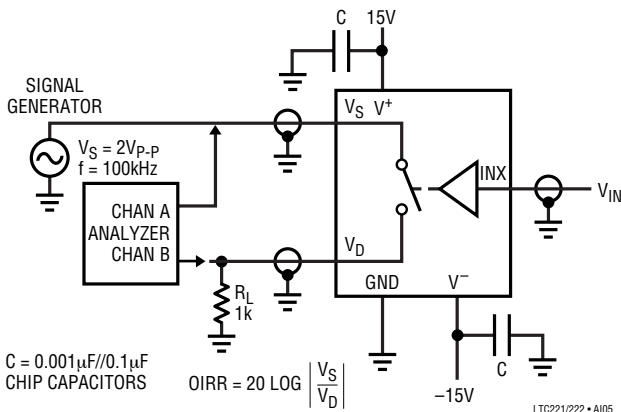

$C = 0.001\mu\text{F}/0.1\mu\text{F}$
CHIP CAPACITORS

$$\text{OIRR} = 20 \text{ LOG} \left| \frac{V_S}{V_D} \right|$$

LTC221/222 • AI05

CCRR-Channel to Channel Crosstalk Test Circuit

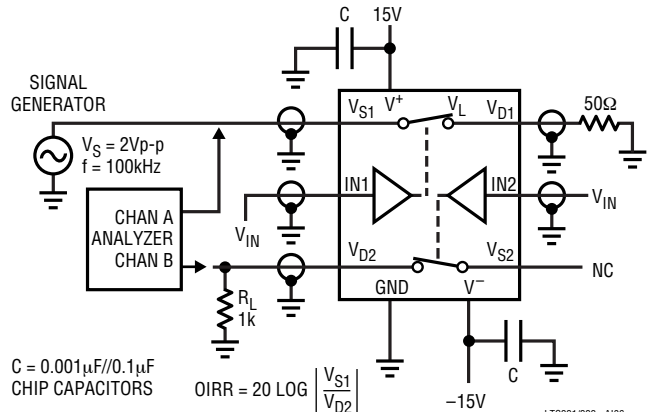

$C = 0.001\mu\text{F}/0.1\mu\text{F}$
CHIP CAPACITORS

$$\text{OIRR} = 20 \text{ LOG} \left| \frac{V_{S1}}{V_{D2}} \right|$$

LTC221/222 • AI06

APPLICATIONS INFORMATION

In-Circuit ESD Test Circuit

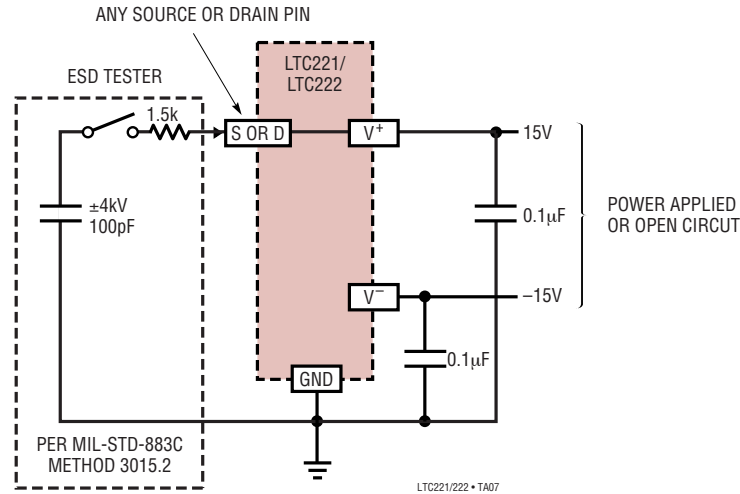

WR Switching Time Test Circuit

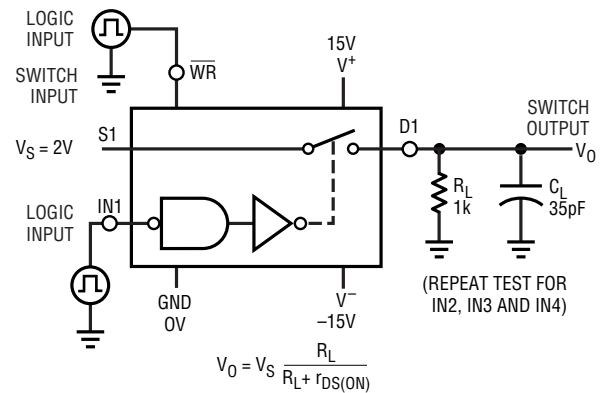
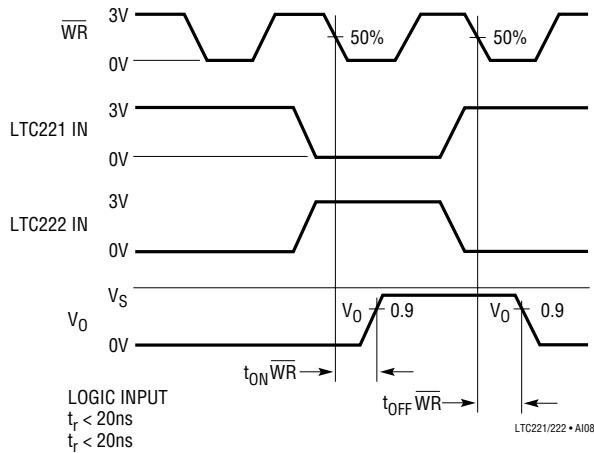

WR Setup Conditions

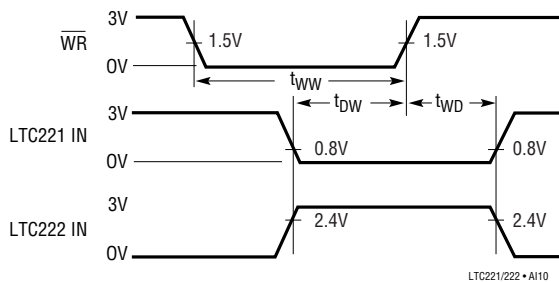

WR/Input Minimum Timing Requirements

PARAMETER	MIN LIMIT	UNITS
t _{WW}	230	ns
t _{DW}	180	ns
t _{WD}	30	ns

APPLICATIONS INFORMATION

Auto Ranging an 8-Channel, 10-Bit A/D Converter

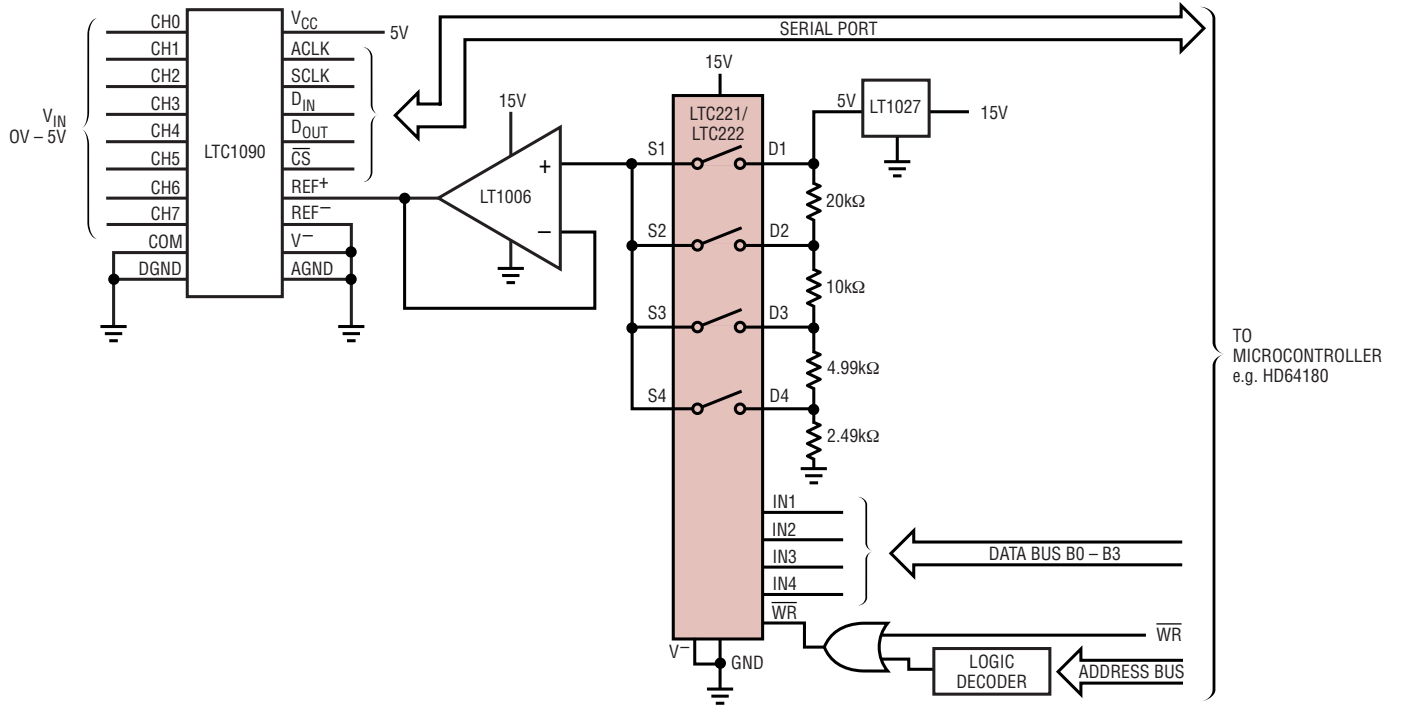

LTC221/222 • A111

APPLICATIONS INFORMATION

8-Channel, 14-Bit A/D Converter

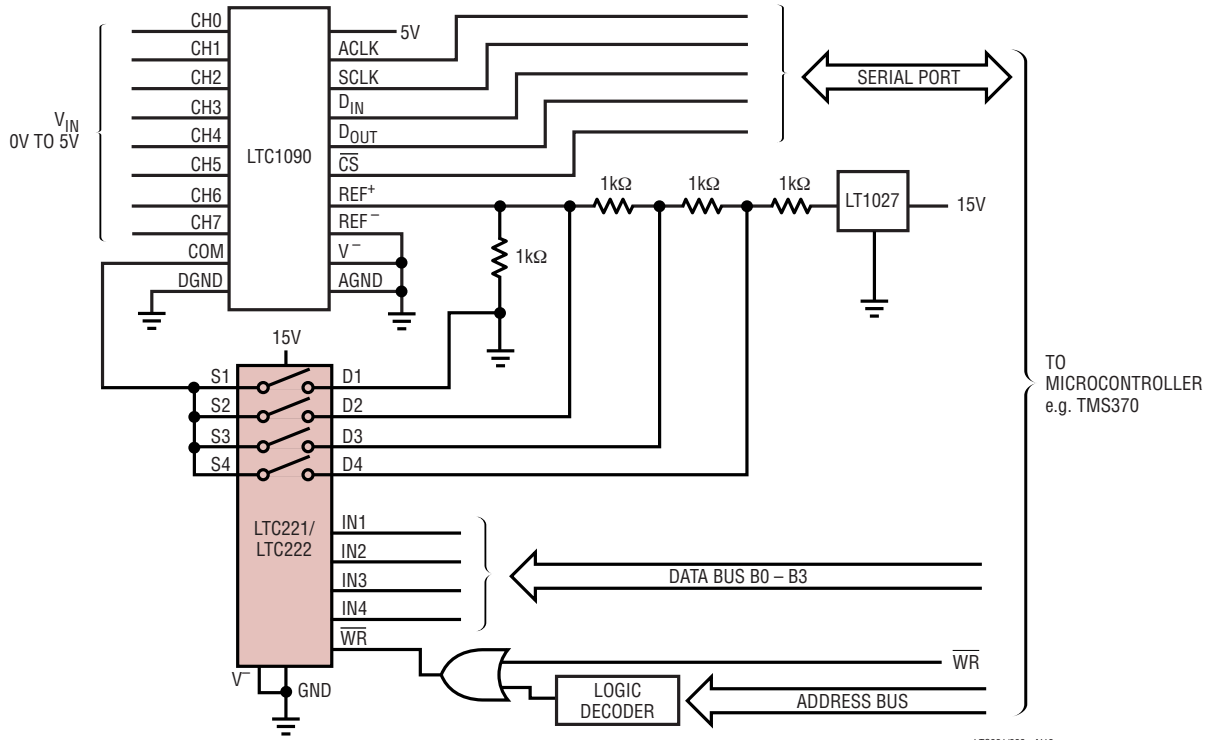

LTC221/222 • AI12

PACKAGE DESCRIPTION

J Package
16-Lead CERDIP (Narrow .300 Inch, Hermetic)
 (Reference LTC DWG # 05-08-1110)

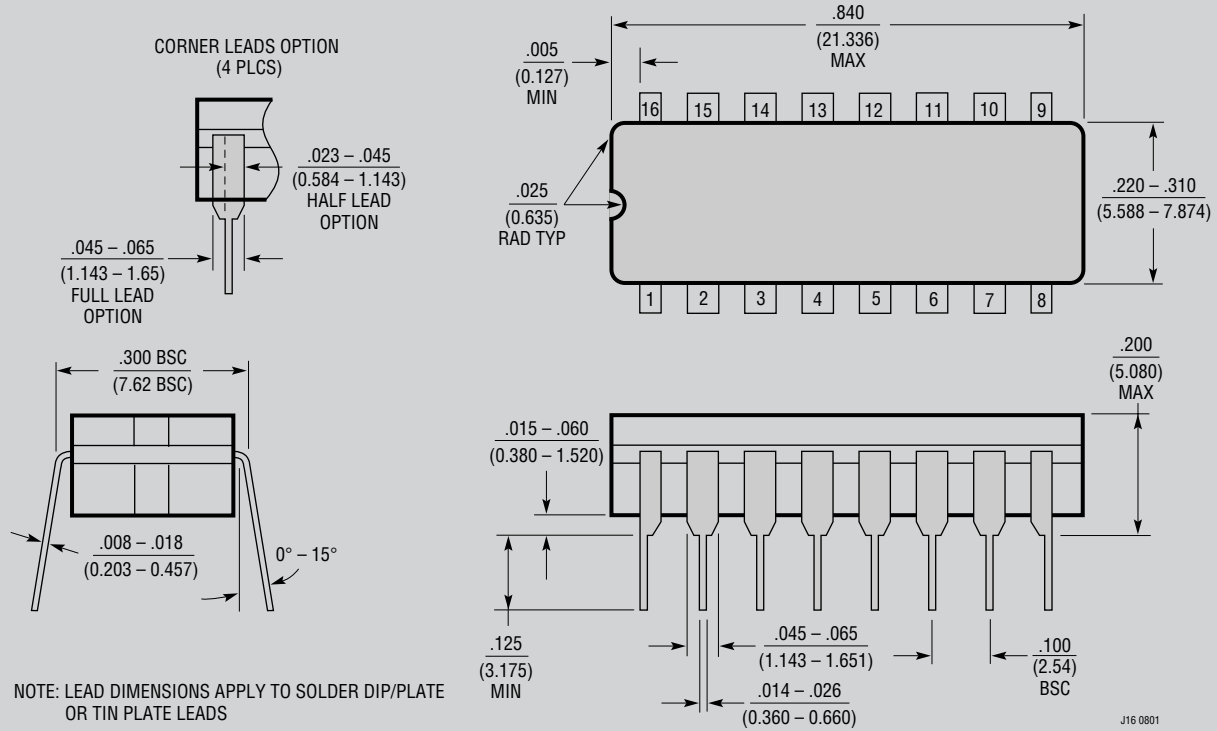

OBSOLETE PACKAGE

PACKAGE DESCRIPTION

N Package
16-Lead PDIP (Narrow .300 Inch)
 (Reference LTC DWG # 05-08-1510)

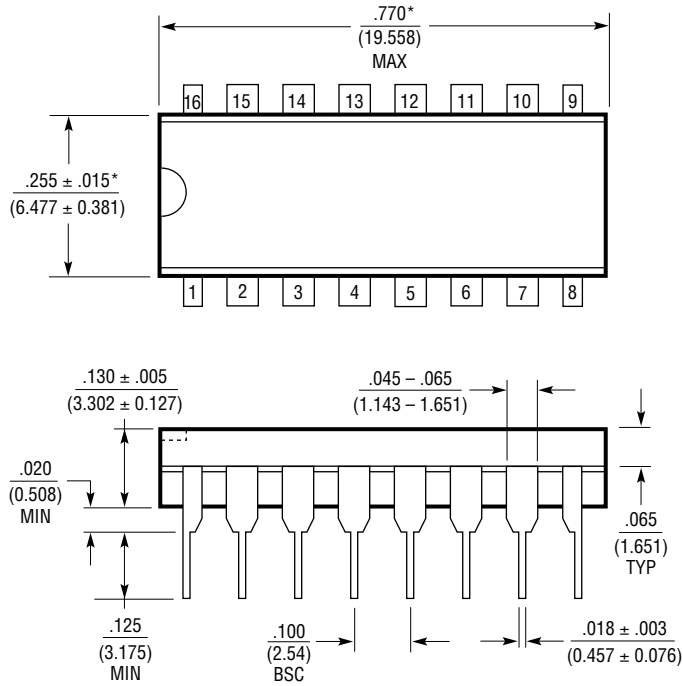

NOTE:
 1. DIMENSIONS ARE $\frac{\text{INCHES}}{\text{MILLIMETERS}}$
 *THESE DIMENSIONS DO NOT INCLUDE MOLD FLASH OR PROTRUSIONS.
 MOLD FLASH OR PROTRUSIONS SHALL NOT EXCEED .010 INCH (0.254mm)

N16 0502

LTC221/LTC222

RELATED PARTS

PART NUMBER	DESCRIPTION	COMMENTS
LTC201/LTC202/LTC203	Micropower, Low Charge Injection, Quad CMOS Analog Switches	DG201/DG202 Compatible
LTC1380/LTC1393	8-Channel/4-Channel Analog Multiplexer with SMBus Interface	3V to $\pm 15V$, 8 Single Ended/4 Differential Inputs
LTC1390/LTC1391	8-Channel, Analog Multiplexer with Serial Interface	3V to $\pm 15V$ Operation

Looking for pricing, stock, or lifecycle information?

Click below to explore more details on WIN SOURCE:

 [View LTC222CS#PBF on WIN SOURCE](#)

 [Linear Technology](#) Information

Optimize Your Supply Chain with WIN SOURCE Solutions

-  Global Sourcing Solution
-  Obsolete Management
-  Cost Control Management
-  Shortage Management
-  Alternative Solution
-  Excess Inventory Management