



**THE DATASHEET OF  
LTC1980EGN#PBF**



# Combination Battery Charger and DC/DC Converter

## FEATURES

- **Single Controller IC Includes Battery Charger Plus DC/DC Converter**
- **Wall Adapter Voltage May be Above or Below Battery Voltage**
- **LDO Controller Allows Simultaneous Charging and Regulating from Wall Adapter Input**
- **Standalone Li-Ion Battery Charger Including Charge Termination, Overvoltage Protection, Shorted-Cell Detection and Battery Recharge**
- Selectable 4.1V, 4.2V, 8.2V and 8.4V Float Voltages
- Simple NiMH and NiCd Battery Charger
- Pin Programmable Regulator Burst Mode® Operation and Shutdown for High Efficiency
- High Efficiency Current Mode 300kHz PWM
- Reduced Component Architecture
- Undervoltage Protection and Soft-Start Ensures Start-Up with Current Limited Wall Adapter
- Small 24-Pin SSOP Package

## APPLICATIONS

- Digital Cameras
- Handheld Computers
- Personal Digital Assistants
- 1W to 10W Uninterruptable Power Supplies

## DESCRIPTION

The LTC<sup>®</sup>1980 integrates PWM power control for charging a battery and converting the battery voltage to a regulated output or simultaneously charging the battery while powering a system load from an unregulated AC wall adapter. Combining these features into a single IC produces a smaller area and lower cost solution compared to presently available multi-IC solutions. The LTC1980 shares the discrete components for both the battery charger and the DC/DC converter thus minimizing size and cost relative to dual controller solutions. Both the battery charger and DC/DC converter use a current mode flyback topology for high efficiency and excellent transient response. Optional Burst Mode operation and power-down mode allow power density, efficiency and output ripple to be tailored to the application.

The LTC1980 provides a complete Li-Ion battery charger with charge termination timer, preset Li-Ion battery voltages, overvoltage and undervoltage protection, and user-programmable constant-current charging. Automatic battery recharging, shorted-cell detection, and open-drain C/10 and wall plug detect outputs are also provided. User programming allows NiMH and NiCd battery chemistries to be charged as well.

LT, LTC and LT are registered trademarks of Linear Technology Corporation. Burst Mode is a registered trademark of Linear Technology Corporation. Patents Pending.

## TYPICAL APPLICATION

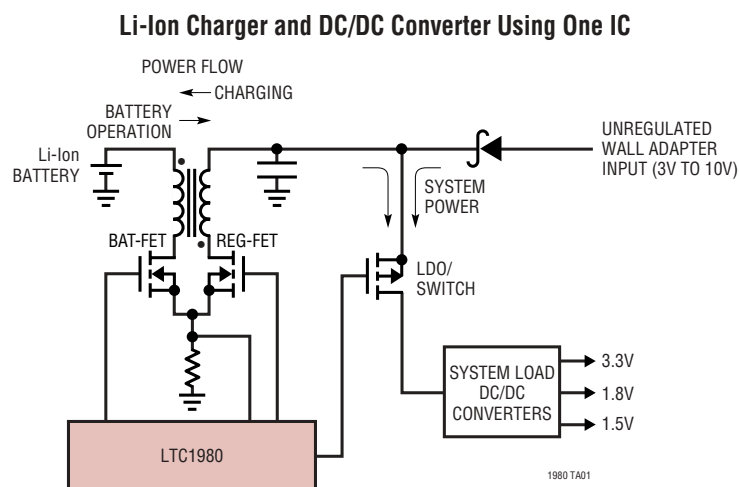

**3.3V Regulator Efficiency vs Load Current**

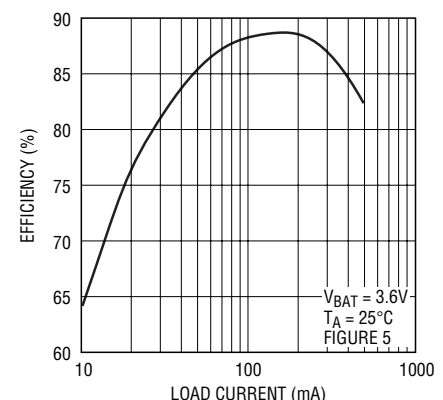

## ABSOLUTE MAXIMUM RATINGS

(Note 1)

$V_{REG}$ to GND .....	-0.5V to 12V
$V_{BAT}$ to GND .....	-0.5V to 12V
PROG, $I_{SENSE}$ .....	-0.5V to 5V
PROGT, REGFB, $V_C$ , BATT1, BATT2	
TIMER, SS .....	-0.5V to $V_{BIAS2}$
LDOFB, LDODRV .....	-0.5V to $V_{REG}$
WA, $V_{BIAS1}$ , REG .....	-0.5V to 12V
MODE .....	-0.5V to $V_{BIAS1}$
$V_{BIAS2}$ .....	-0.5V to 5V
OVP .....	-0.5V to 5V
PGND to GND .....	Connect Together
Operating Ambient Temperature Range	
(Note 2) .....	-40°C to 85°C
Storage Temperature Range .....	-65°C to 125°C
Lead Temperature (Soldering, 10 sec).....	300°C

## PACKAGE/ORDER INFORMATION

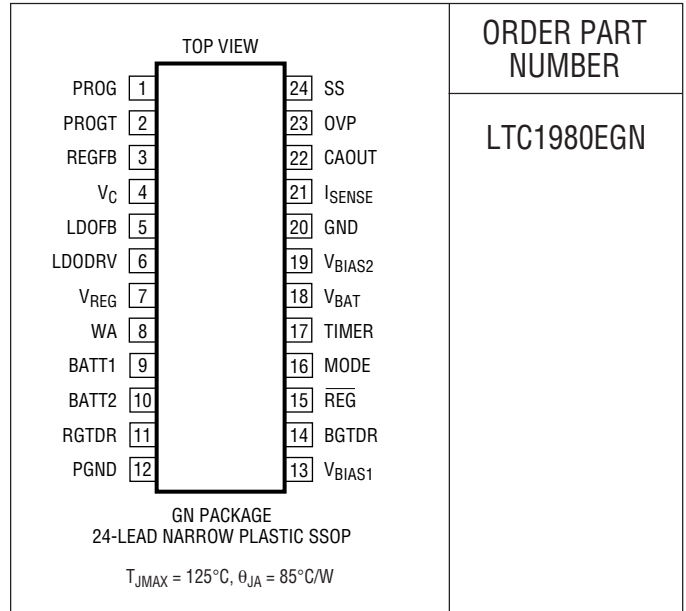

ORDER PART NUMBER

LTC1980EGN

Consult LTC Marketing for parts specified with wider operating temperature ranges.

## ELECTRICAL CHARACTERISTICS

The ● denotes the specifications which apply over the full operating temperature range, otherwise specifications are at  $T_A = 25^\circ\text{C}$ .  $V_{BAT} = 2.4\text{V}$ ,  $V_{REG} = 5\text{V}$ ,  $V_{BAT}$  unloaded.

SYMBOL	PARAMETER	CONDITIONS	MIN	TYP	MAX	UNITS
$V_{BAT}$	Positive Supply Voltage, $V_{BAT}$		2.85		10	V
$V_{REG}$	Positive Supply Voltage, $V_{REG}$		2.85		10	V
$V_{FB}$	Feedback Voltage	REGFB Tied to $V_C$	● 1.194	1.225	1.256	V
$V_{PROGT}$	Voltage on PROGT Pin	PROGT Tied to $V_C$	1.194	1.225	1.256	V
$I_{BURST}$	Burst Mode Operation Supply Current, Quiescent, $V_{REG}$	Regulator Mode, REGFB = 1.5V		0.75		mA
$I_{HIGH}$	Supply Current, Quiescent, $V_{REG}$	Regulator Mode, REGFB = 0V	●	2	4.3	mA
$I_{SHDN}$	Supply Current in Shutdown Mode, $V_{REG}$	Mode = 0V			15	$\mu\text{A}$
$V_{UVL}$	Positive-Going Undervoltage Lockout Voltage	From Either $V_{BAT}$ or $V_{REG}$	2.45	2.7	2.85	V
$V_{UVHYS}$	Undervoltage Lockout Hysteresis	From Either $V_{BAT}$ or $V_{REG}$		100		mV
$I_{SS}$	Soft-Start Ramp Current	BATT1 = 0, BATT2 = 0, Charger Mode		10		$\mu\text{A}$
$V_{FLOAT0}$	Output Float Voltage in Constant Voltage Mode	BATT1 = 0, BATT2 = 0	● 4.059	4.1	4.141	V
$V_{FLOAT1}$	Output Float Voltage in Constant Voltage Mode	BATT1 = 1, BATT2 = 0	● 4.158	4.2	4.242	V
$V_{FLOAT2}$	Output Float Voltage in Constant Voltage Mode	BATT1 = 0, BATT2 = 1 (Note 3)	● 8.118	8.2	8.282	V
$V_{FLOAT3}$	Output Float Voltage in Constant Voltage Mode	BATT1 = 1, BATT2 = 1 (Note 3)	● 8.316	8.4	8.484	V
$V_{FLOAT4}$	Output Float Voltage in Constant Voltage Mode	BATT1 = Open, BATT2 = Don't Care Measured from OVP Input	● 1.207	1.225	1.243	V
$V_{RCHG0}$	Recharge Threshold, Delta Voltage with Respect to Float Voltage	BATT2 = 0, BATT1 = 0 or 1		200		mV
$V_{RCHG1}$	Recharge Threshold, Delta Voltage with Respect to Float Voltage	BATT2 = 1, BATT1 = 0 or 1		400		mV

## ELECTRICAL CHARACTERISTICS

The ● denotes the specifications which apply over the full operating temperature range, otherwise specifications are at  $T_A = 25^\circ\text{C}$ .  $V_{\text{BAT}} = 2.4\text{V}$ ,  $V_{\text{REG}} = 5\text{V}$ ,  $V_{\text{BAT}}$  unloaded.

SYMBOL	PARAMETER	CONDITIONS	MIN	TYP	MAX	UNITS
$V_{\text{RCHG2}}$	Recharge Threshold, Delta Voltage with Respect to Float Voltage, Measured at OVP	BATT 1 = Open		60		mV
$V_{\text{LT0}}$	Charger Shorted Cell Threshold	BATT2 = 0	2.55	2.7	2.8	V
$V_{\text{LT1}}$	Charger Shorted Cell Threshold	BATT2 = 1	5.2	5.4	5.65	V
$I_{\text{BLDO}}$	Input Bias Current, Low Dropout Regulator	Measured at LDOFB Pin		1.0		$\mu\text{A}$
$g_{\text{mldo}}$	Transconductance, Low Dropout Regulator	Measured from LDOFB to LDODRV		350		$\mu\text{mhos}$
$V_{\text{OLLDO}}$	Output Low Voltage, Low Dropout Regulator				0.1	V
$V_{\text{OHLDO}}$	Output High Voltage, Low Dropout Regulator		$V_{\text{REG}} - 0.1$			V
$I_{\text{OUTLDO}}$	Low Dropout Regulator Output Current, Source/Sink			$\pm 20$		$\mu\text{A}$
$A_{\text{VOL}}$	Error Amplifier Open-Loop Voltage Gain	From REGFB to $V_C$		60		dB
$I_{\text{BEA}}$	Error Amplifier Input Bias Current		-0.1		0.1	$\mu\text{A}$
$V_{\text{OLEA}}$	Error Amplifier Output Low Voltage		0		0.5	V
$V_{\text{OHEA}}$	Error Amplifier Output High Voltage	SS = Open	1.4		2	V
$I_{\text{OUT}}$	Error Amplifier Output Source Current Error Amplifier Output Sink Current			0.5 -1.2		mA mA
$g_{\text{mflt}}$	Float Voltage Error Amplifier Transconductance	Measured from OVP to SS, Charger Mode, BATT1 = Open		65		$\mu\text{mhos}$
$I_{\text{BFLT}}$	Float Voltage Error Amplifier Input Current (Measured at OVP Input)		-0.1		0.1	$\mu\text{A}$
$V_{\text{OS1}}$	Current Amplifier Offset Voltage		-6		6	mV
$I_{\text{BIS}}$	Input Bias Current, $I_{\text{SENSE}}$ Input			-100		$\mu\text{A}$
$A_{\text{VCA}}$	Current Amplifier Voltage Gain	Measured from $I_{\text{SENSE}}$ to CAOUT Pin	2.3	2.44	2.55	V/V
$R_{\text{PROG}}$	PROG Pin On Resistance			400		$\Omega$
$I_{\text{PROG}}$	PROG Pin Leakage Current			100		nA
$f_{\text{S}}$	Switching Frequency		● 260	300	340	kHz
$t_r, t_f$	Driver Output Transition Times	$C_L = 15\text{pF}$		10		ns
$t_{\text{BREAK}}$	Driver Output Break Times	$V_{\text{BAT}} = V_{\text{REG}} = 10\text{V}$		100		ns
$f_{\text{TIMER}}$	Timer Frequency	$C = 1000\text{pF}$		4.5		kHz
$I_{\text{TIMER1}}$	TIMER Pin Source Current			-4		$\mu\text{A}$
$I_{\text{TIMER2}}$	TIMER Pin Sink Current			4		$\mu\text{A}$
$R_{\text{REG}}$	$\overline{\text{REG}}$ On Resistance			68		$\Omega$
$I_{\text{REGPD}}$	$\overline{\text{REG}}$ Pull-Down Current		2	5	9	$\mu\text{A}$
$I_{\text{REGLK}}$	$\overline{\text{REG}}$ Leakage Current			60		nA
$V_{\text{VTHREG}}$	$\overline{\text{REG}}$ Logic Threshold		0.3		1.3	V
$V_{\text{IL1}}$	Digital Input Low Voltage, Negative-Going, Wall Adapter (WA)	$V_{\text{REG}} = 5\text{V}$	1.185	1.221	1.247	V
$V_{\text{IH1}}$	Digital Input High Voltage, Positive-Going, Wall Adapter (WA)	$V_{\text{REG}} = 5\text{V}$	1.195	1.226	1.257	V
$V_{\text{IL2}}$	Digital Input Low Voltage, BATT1				100	mV
$V_{\text{IH2}}$	Digital Input High Voltage, BATT1		$V_{\text{BIAS2}}$ -100			V

## ELECTRICAL CHARACTERISTICS

The ● denotes the specifications which apply over the full operating temperature range, otherwise specifications are at  $T_A = 25^\circ\text{C}$ .  $V_{\text{BAT}} = 2.4\text{V}$ ,  $V_{\text{REG}} = 5\text{V}$ ,  $V_{\text{BAT}}$  unloaded.

SYMBOL	PARAMETER	CONDITIONS	MIN	TYP	MAX	UNITS
$V_{\text{P2}}$	Digital Input Pull-Up Voltage, BATT1	BATT1 Input Floating		1.6		V
$V_{\text{IL3}}$	Digital Input Low Voltage, BATT2				0.3	V
$V_{\text{IH3}}$	Digital Input High Voltage, BATT2		2			V
$I_{\text{I1}}$	Digital Input Current, WA		-5		5	$\mu\text{A}$
$I_{\text{I2}}$	Digital Input Current, BATT1		-10		10	$\mu\text{A}$
$I_{\text{I3}}$	Digital Input Current, BATT2		-1		1	$\mu\text{A}$

**Note 1:** Absolute Maximum Ratings are those values beyond which the life of a device may be impaired.

**Note 2:** The LTC1980E is guaranteed to meet performance specifications from  $0^\circ\text{C}$  to  $70^\circ\text{C}$ . Specifications over the  $-40^\circ\text{C}$  to  $85^\circ\text{C}$  operating

temperature range are assured by design, characterization and correlation with statistical process controls.

**Note 3:**  $T_A = 0^\circ\text{C}$  to  $70^\circ\text{C}$ .

## TYPICAL PERFORMANCE CHARACTERISTICS

**Feedback Reference Voltage vs Temperature**

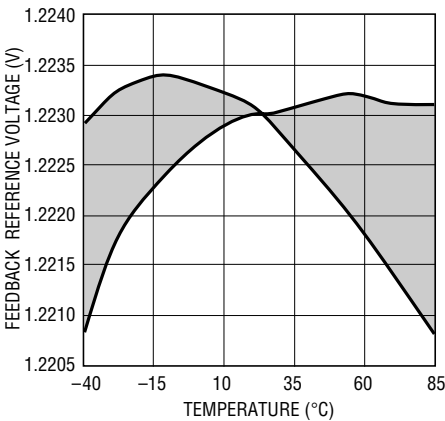

1980 G01

**Switching Frequency Variance vs Temperature**

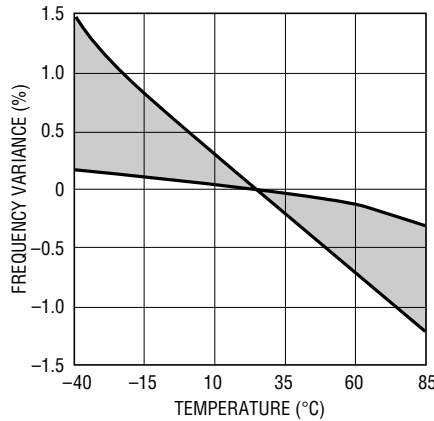

1980 G02

**Regulator Load Regulation**

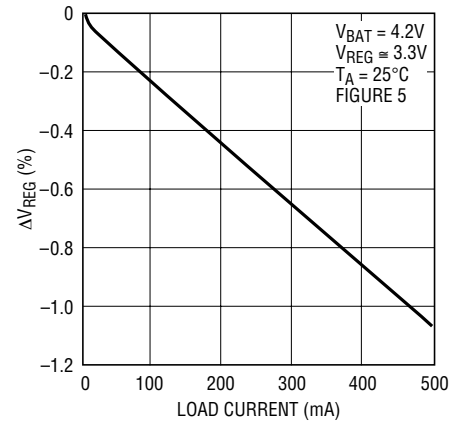

1980 G03

**3.3V Regulator Efficiency vs Load Current**

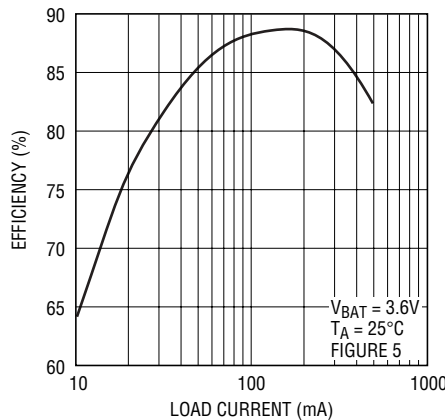

1980 G04

**5V Regulator Efficiency vs Load Current**

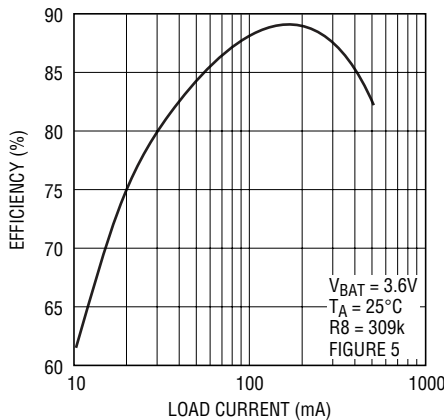

1980 G05

**Regulator Load Step Response**

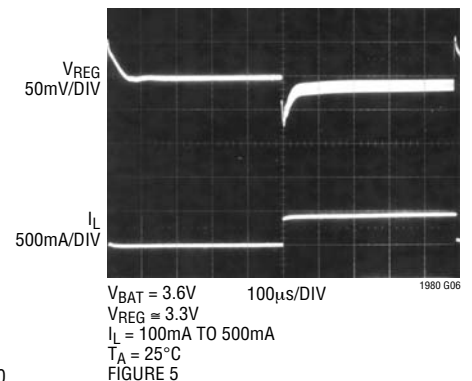

1980 G06

# TYPICAL PERFORMANCE CHARACTERISTICS

**Typical BGTR and RGTDR Waveforms**

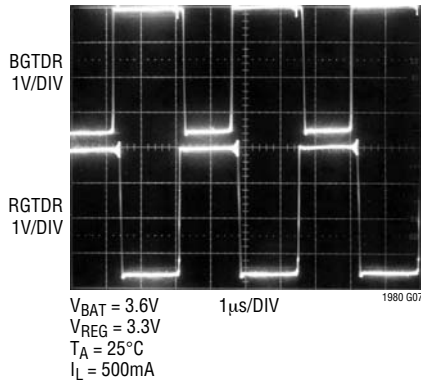

**Typical  $I_{SENSE}$  Waveforms, Regulator**

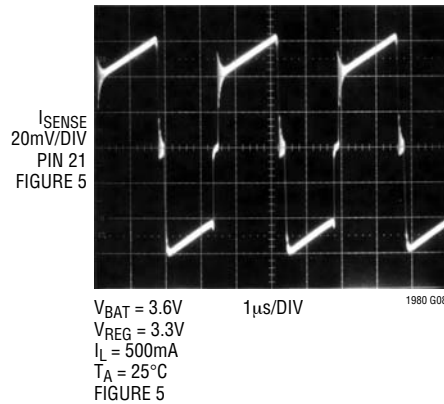

**Typical Operation with Burst Mode Operation Disabled**

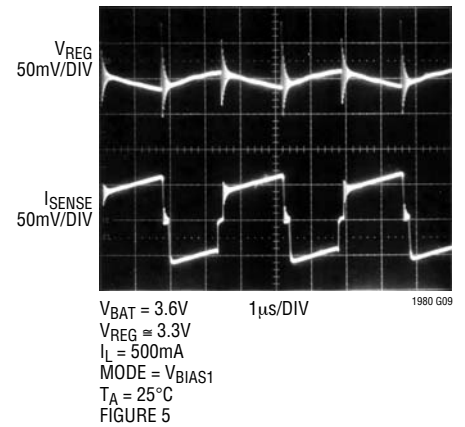

**Burst Mode Circuit Operation**

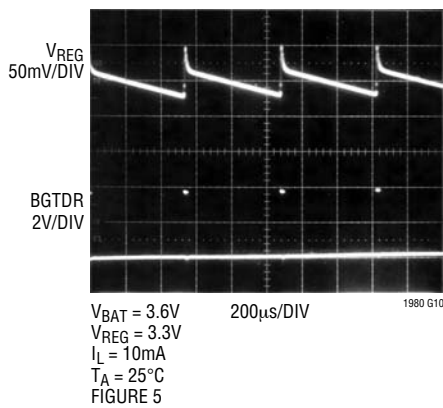

**Regulator Output Transient Response—Wall Adapter Removal**

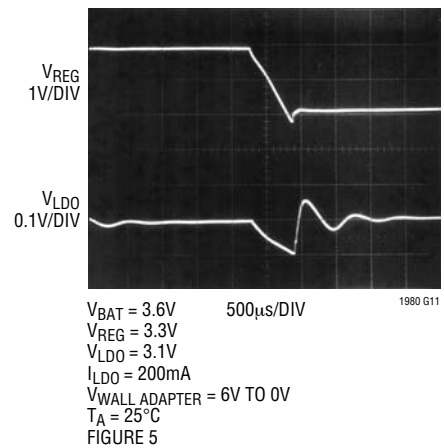

**Regulator Output Transient Response—Wall Adapter “Hot Plugged”**

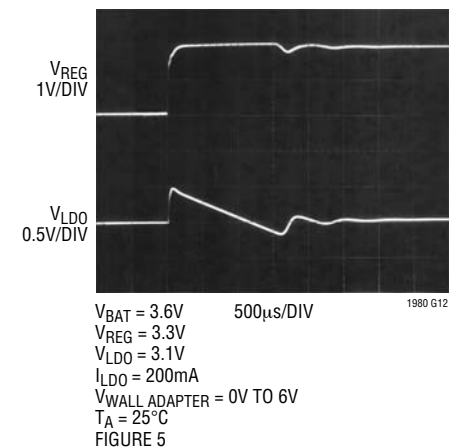

**Mode Pin Input Current vs  $V_{IN}$**

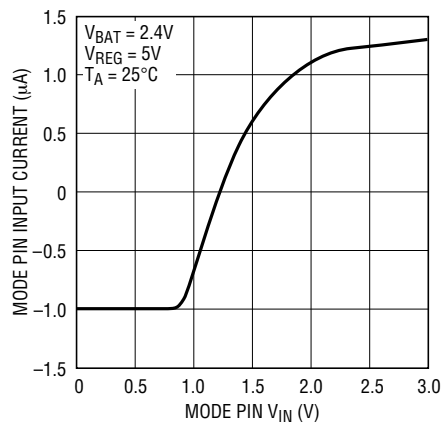

**Typical  $C_{TIMER}$  Waveform**

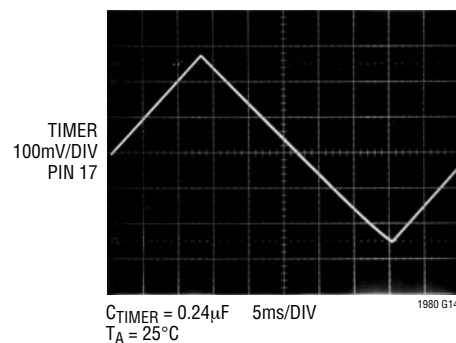

## PIN FUNCTIONS

**PROG (Pin 1):** Charge Current Ratio Programming Pin. Programs the full charge current when the charger is in the constant current mode. A resistor placed between the PROG pin and the PROGT pin (Pin 2) determines the charge current. The PROG pin connects to an open drain MOSFET which turns on for full current and is off when trickle charging.

**PROGT (Pin 2):** Trickle Charge Programming Pin. Programs the trickle charge current for a deeply discharged battery. Two resistors are used, one between the PROGT pin and CA<sub>OUT</sub> (Pin 22) and another from PROGT to ground. A capacitor between the PROGT pin and V<sub>C</sub> (Pin 4) provides compensation for the constant current feedback loop.

**REGFB (Pin 3):** DC/DC Converter Feedback Pin. This pin is used to program the DC/DC converter output voltage when the LTC1980 is in the DC/DC (regulator) converter mode. An external resistor divider from V<sub>REG</sub> to REGFB to ground programs the output voltage. The virtual reference voltage (V<sub>REF</sub>) on this pin is 1.225V. A series RC from the REGFB pin to V<sub>C</sub> (Pin 4) provides pole-zero compensation for the regulator outer loop.

**V<sub>C</sub> (Pin 4):** Control Signal of the Inner Loop of the Current Mode PWM. A common current mode loop is used by the battery charger and voltage regulator functions. Minimum duty factor (measured on BGTDR (Pin 14) in regulator mode and RGTDR (Pin 11) in charger mode) occurs at approximately 1V. Duty factor increases as V<sub>C</sub> increases. This part includes slope compensation, so there is some variation in V<sub>C</sub> for minimum and maximum duty factor as V<sub>REG</sub> or V<sub>BAT</sub> is varied.

**LDOFB (Pin 5):** Low Dropout Regulator Feedback Pin. This pin is used to program the low dropout linear regulator output voltage. An external resistor divider from the output of the LDO regulator (drain of the external MOSFET) to LDOFB to ground programs the output voltage. The virtual reference voltage on this pin is 1.225V.

**LDODRV (Pin 6):** Low Dropout Error Amplifier Output. This pin drives the gate of an external PMOS pass transistor. This pin is pulled up to V<sub>REG</sub> (shutting off the pass transistor) if MODE (Pin 16) is grounded or if undervoltage occurs.

**V<sub>REG</sub> (Pin 7):** Connection Point to the DC/DC Converter Side of the Combo Charger/Converter Circuit.

**WA (Pin 8):** Wall Adapter Comparator Input. An external resistor divider from the wall adapter output to WA to ground sets the threshold which determines if charging can occur. If the wall adapter is below this threshold, the LTC1980 assumes the wall adapter is not present and the charger shuts down. Wall adapter sense threshold is set higher than the DC/DC converter output voltage to insure correct operation.

**BATT1 (Pin 9):** Logic Input Pin for Selecting Preprogrammed Li-Ion Charge Voltage. See Truth Table logic settings.

**BATT2 (Pin 10):** Logic Input Pin for Selecting Preprogrammed Li-Ion Charge Voltage. The following combinations of BATT1 and BATT2 select the correct Li-Ion charge voltage. See Truth Table.

BATT2	BATT1	FLOAT VOLTAGE
0	0	4.1V
0	1	4.2V
1	0	8.2V
1	1	8.4V
Don't Care	Open	Externally Set Via OVP

Logic 1 = V<sub>BIAS2</sub> (Pin 19), Logic 0 = GND

**RGTDR (Pin 11):** DC/DC Converter (Regulator) Side Gate Drive Pin. This pin provides gate drive to the external MOSFET (REG-FET) that connects to V<sub>REG</sub> via the transformer.

**PGND (Pin 12):** Power Ground. Refer to the Applications Information section for proper use of ground and power ground connections.

**V<sub>BIAS1</sub> (Pin 13):** Internally Generated Power Bus. Bypass this pin with a 1μF or larger ceramic capacitor (or other low ESR capacitor) to PGND (Pin 12). Do not connect any load to this pin.

**BGTDR (Pin 14):** DC/DC Converter (Battery) Side Gate Drive Pin. This pin provides gate drive to the external MOSFET (BAT-FET) that connects to V<sub>BAT</sub> via the transformer.

## PIN FUNCTIONS

**REG (Pin 15):** Bidirectional Regulator Mode Control Pin. A pull-up resistor is required between this pin and  $V_{BIAS2}$ . This pin is open when charging normally, has a weak pull-down (approximately  $5\mu\text{A}$ ) when conditioning the battery and a strong pull-down when in regulator mode. Pulling this pin low forces the IC into regulator mode.

**MODE (Pin 16):** Selects different operating modes in both charger and DC/DC converter configurations. Also enables and disables Burst Mode operation. See Mode Pin Operation table in Application section.

**TIMER (Pin 17):** A timing capacitor on this pin determines the normal charge time for charge termination.

$$C(\mu\text{F}) = 0.25 \cdot \text{Time (Hours)}$$

**$V_{BAT}$  (Pin 18):** This pin connects to the positive terminal of the battery and the battery side of the power converter.

**$V_{BIAS2}$  (Pin 19):** Internally Generated Voltage. Bypass this pin with a  $1\mu\text{F}$  or larger ceramic capacitor (or other low ESR capacitor). Do not connect any load to this pin.

**GND (Pin 20):** Signal Ground. This pin should Kelvin-connect to the current sense resistor ( $R_{SENSE}$ ).

**$I_{SENSE}$  (Pin 21):** Current Sense Input Pin. Connects internally to a current amplifier and zero current comparator. This pin should Kelvin-connect to the current sense resistor ( $R_{SENSE}$ ).

**CAOUT (Pin 22):** Current Amplifier Output. A program resistor connects between this pin and PROGT (Pin 2) to set the charge current (in constant-current mode).

**OVP (Pin 23):** Overvoltage Protection. This pin connects to the tap on an optional external voltage divider connected across the battery. This allows nonstandard float voltages to be used for the battery charger. Overvoltage, restart and undervoltage thresholds will also be affected by the external voltage division ratio. To use this pin, BATT1 (Pin 9) must float.

**SS (Pin 24):** Soft-Start. A capacitor between this pin and ground sets the battery charge ramp rate. Battery charge current is very low the moment after the converter switches from DC/DC converter (regulator) mode to battery charger mode then ramps up to final battery charge current from there. This insures that the wall adapter is not loaded down with a large inrush current that could prevent correct battery charger operation.

The same capacitor, which sets the soft-start ramp rate, also sets the compensation for the battery float voltage control loop.

**BLOCK DIAGRAM**

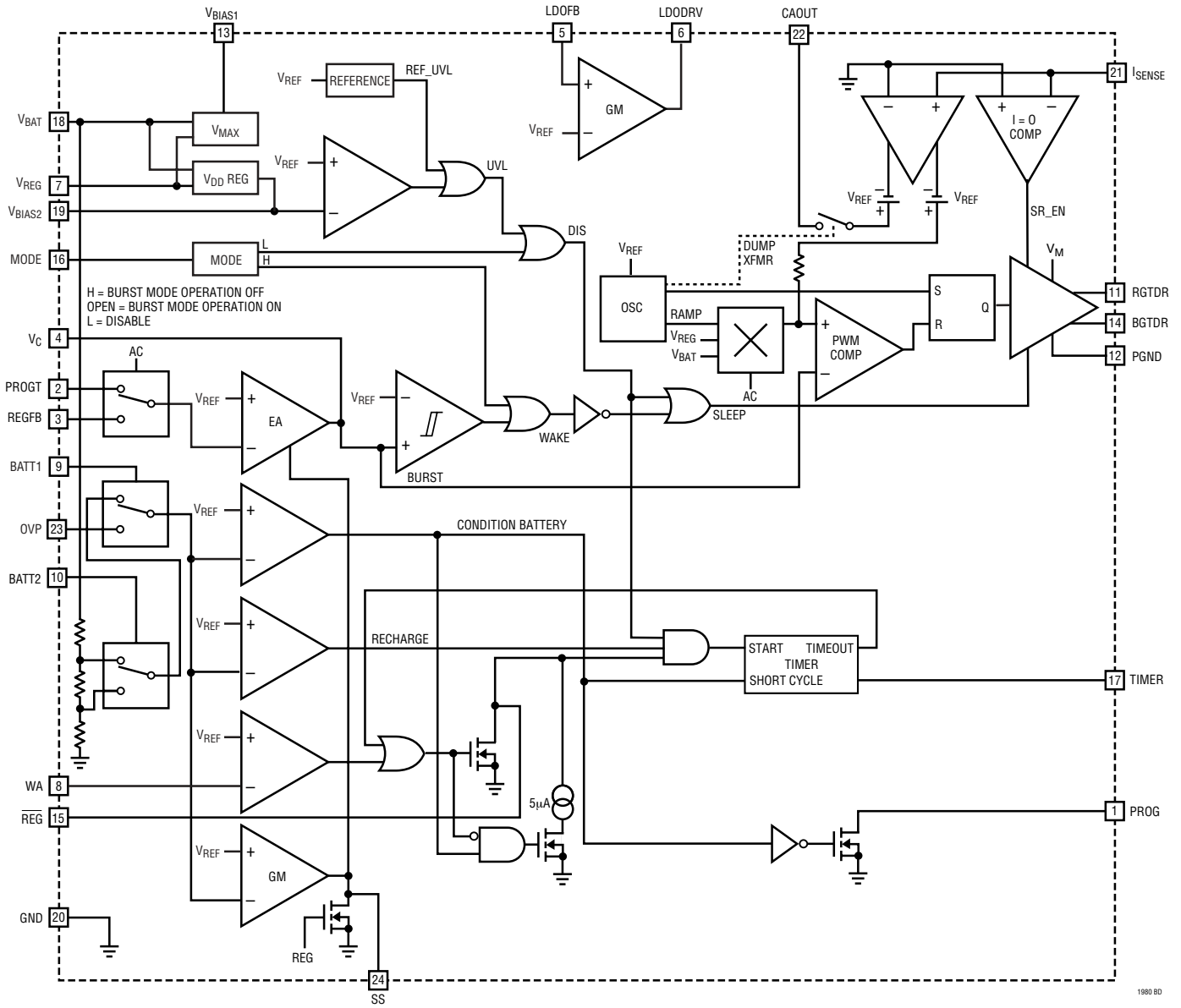

## OPERATION

The LTC1980 is an IC designed to provide a regulated voltage to a system load from an unregulated or regulated wall adapter, or from a battery and also charge a battery, thereby providing an uninterruptable power source for the system. When the wall adapter is present it provides power to the system load and, if needed, a portion of the power can be used to simultaneously charge the battery. If the wall adapter is removed, the LTC1980 uses the battery as a power source to continue providing a regulated output voltage to power the system.

Combining these two functions into a single IC reduces circuit area compared to presently available solutions

(Figure 1). The unique bidirectional power converter topology (Figure 2) accounts for much of the area savings. A transformer based design allows the wall adapter voltage to be less than or greater than the battery voltage.

The LTC1980 includes a 300kHz DC/DC PWM converter that operates in two modes. The first mode is when the wall adapter is present and the LTC1980 is used to charge the battery using a constant-current/constant-voltage charge scheme. The second mode is when the wall adapter is removed and the battery powers the LTC1980 and the DC/DC converter generates a regulated output voltage.

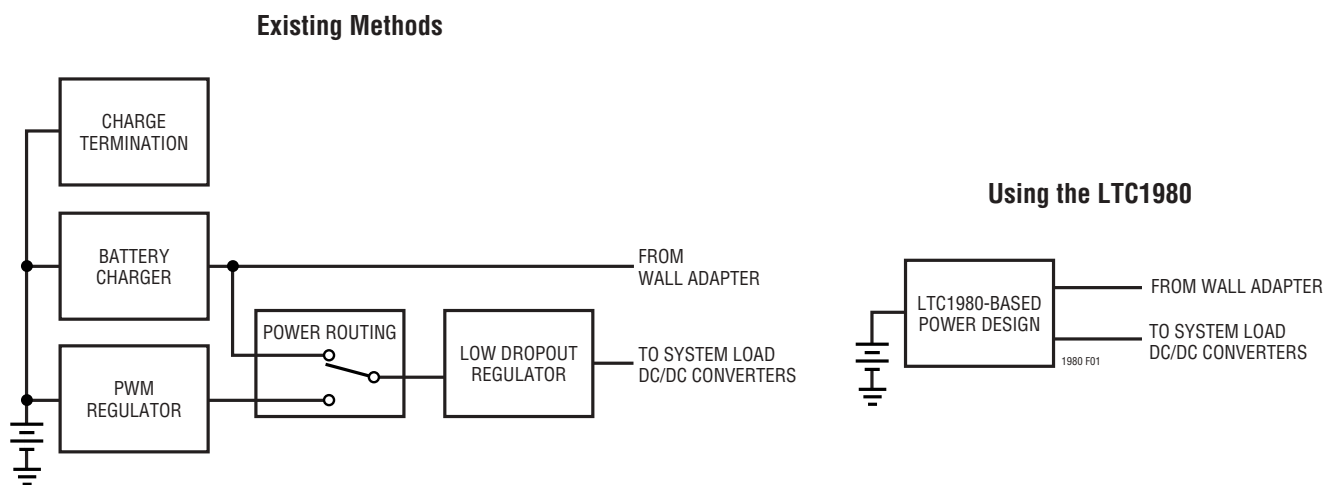

Figure 1. Portable Power Systems

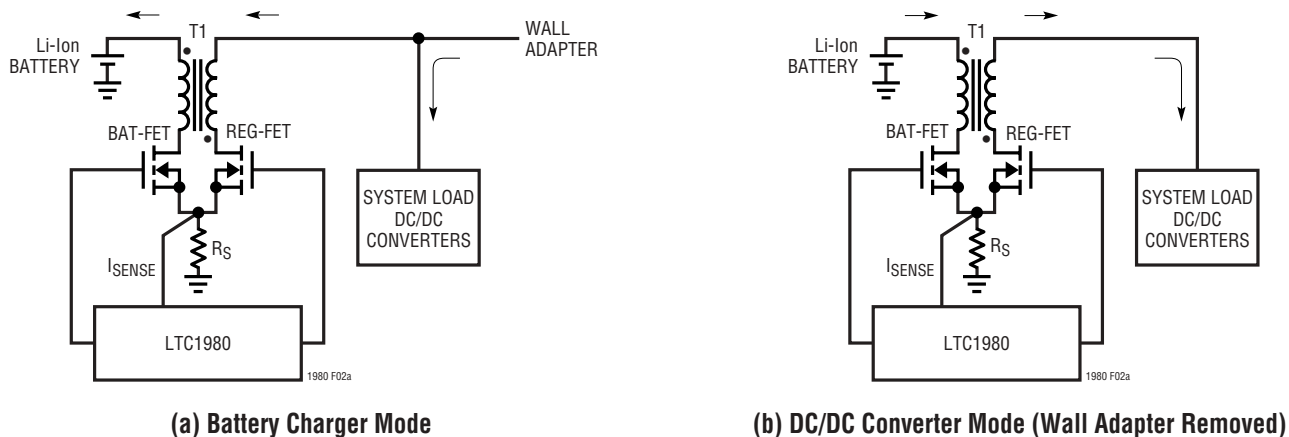

Figure 2. LTC1980 Bidirectional Power Conversion

## OPERATION

### Lithium-Ion Battery Charger Operation

With the wall adapter power applied, the LTC1980 operates as a constant-current/constant-voltage PWM battery charger, with a portion of the adapter current used for charging and the rest flowing to the system load through an optional low dropout regulator.

A charge cycle begins when the voltage at  $V_{REG}$  exceeds the undervoltage lockout threshold level and the IC is enabled via the  $\overline{MODE}$  pin. If the battery has been deeply discharged and the battery voltage is less than 2.7V, the charger will begin with the programmed trickle charge current.

When the battery exceeds 2.7V, the charger begins the constant-current portion of the charge cycle with the charge current equal to the programmed level. As the battery accepts charge, the voltage increases. When the battery voltage reaches the recharge threshold, the programmable timer begins. Constant-current charging continues until the battery approaches the programmed charge voltage of 4.1V or 4.2V/cell at which time the charge current will begin to drop, signaling the beginning of the constant-voltage portion of the charge cycle. The charger

will maintain the programmed preset float voltage across the battery until the timer terminates the charge cycle. During trickle charging, if the battery voltage remains below 2.7V for 1/4 of the total programmed charge time, the battery may be defective and the charge cycle ends. Also, if a battery open circuit is detected, the charge cycle ends immediately. The charger can be shut down by pulling the  $\overline{REG}$  pin low, although the timer will continue until it times out.

### Power Converter Operation from Battery

When the AC adapter is removed, the LTC1980 operates as a DC/DC PWM converter using the battery for input power to provide a regulated output voltage for the system load. The LTC1980 is a current mode switcher. This means that the switch duty cycle is directly controlled by switch current rather than by output voltage or current. Battery charger operation will be described for the simplified diagram (Figure 3). At the start of the oscillator cycle, latch U9 is set causing M2 to turn on. When switch current reaches a predetermined level M2 turns off and M1 turns on. This level is set by the control voltage at the output of error amplifier U10.

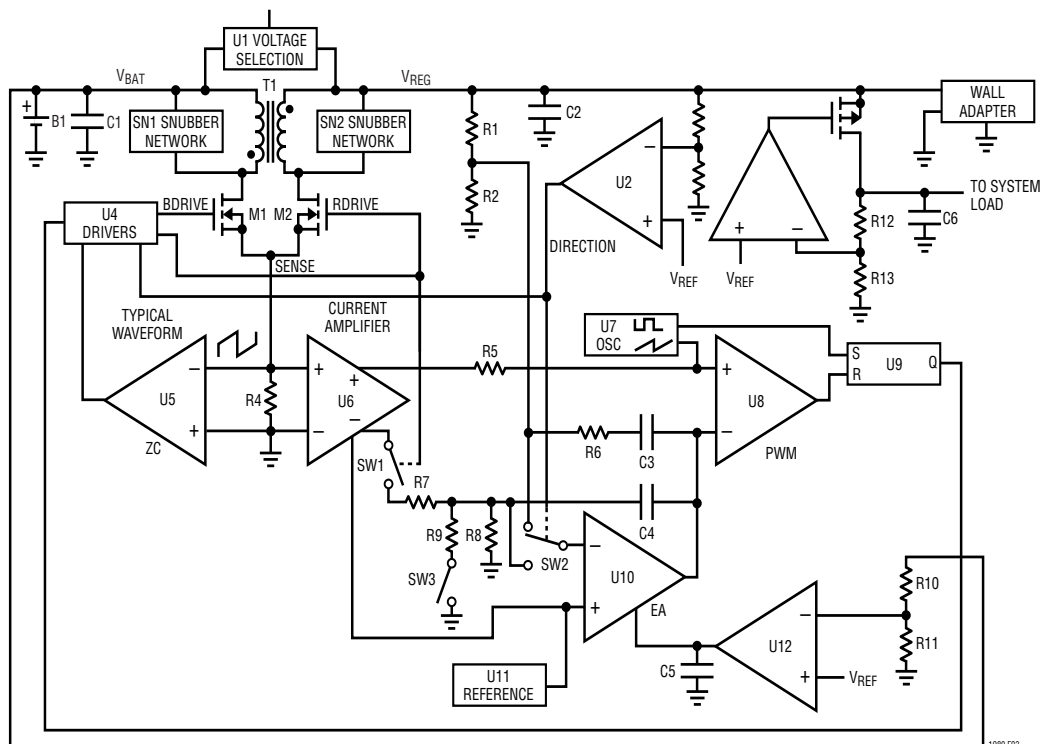

Figure 3. Simplified Diagram—Power Converter

1980 F03

1980f

## OPERATION

Transformer current is sensed across  $R_S$ , gained up via U6 and sampled through switch SW1. The current in R7 is a scaled-down replica of the battery charging current pulses from the transformer. During battery charging, switch SW2 is in the down position connecting R7, R8, R9 and C4 to the inverting input of amplifier U10 forming an integrator which closes the outer loop of the converter and establishes constant current charging. U12 is a  $g_m$  amplifier that clamps U10 as the battery float voltage is reached. R10 and R11 set the float voltage and C5 compensates this loop and provides a soft-start function.

### DC/DC Converter Operation

When the LTC1980 is operating as a DC/DC converter, M1 turns on at the start of the oscillator cycle. When transformer current reaches a predetermined level set by U10's output voltage, M1 turns off and M2 turns on. SW2 is in the up position forming an integrator with zero, which compares the output voltage (via R1 and R2 to reference U11 establishing the output voltage.

## APPLICATIONS INFORMATION

### Setting Battery Charge Current

Referring to the simplified schematic in Figure 4, the average current through R7 must equal the current through  $R_{TRK}$  with switch SW3 open. This leads to the equation for setting the trickle charge current:

$$R_{TRK} = \frac{V_{REF} \cdot R7}{I_{TRICKLE} \cdot R_S \cdot A_V}$$

Normal charge current is set via the parallel combination of  $R_{TRK}$  and  $R_{CHRG}$  which leads to the following equation for  $R_{CHRG}$

$$R_{CHRG} = \frac{V_{REF} \cdot R7}{(I_{NORMAL} - I_{TRICKLE}) \cdot R_S \cdot A_V}$$

where  $A_V = 2.44$  and  $V_{REF} = 1.225V$ . The suggested value for R7 is 10k.

### Setting the Float Voltage

Pin selectable 4.1V, 4.2V, 8.2V, and 8.4V Li-Ion float voltages are available. Other float voltages may be set via external resistors. The following combinations of logic inputs BATT1 and BATT2 determine the float voltage.

BATT2	BATT1	FLOAT VOLTAGE
0	0	4.1V
0	1	4.2V
1	0	8.2V
1	1	8.4V
Don't Care	Open	Externally Set via OVP

where logic 0 = GND and logic 1 =  $V_{BIAS2}$  (Pin 19)

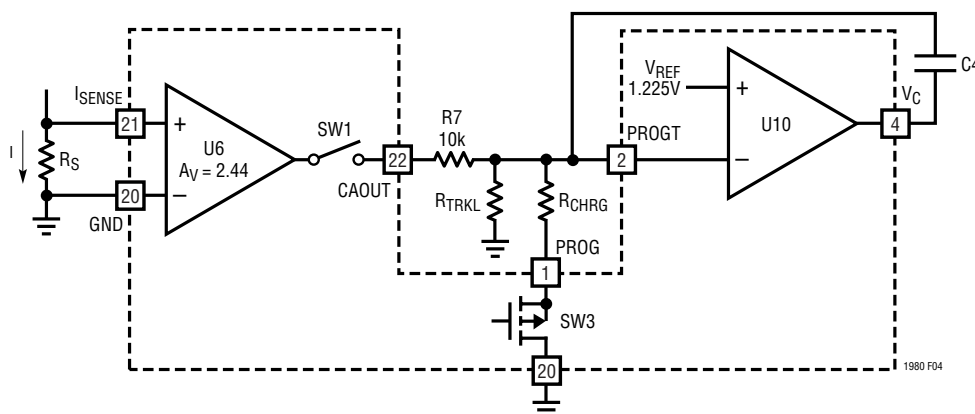

Figure 4. Battery Charger Current Control Loop

## APPLICATIONS INFORMATION

An external resistor divider (Figure 3) can be used to program other float voltages. Resistor values are found using the following equation:

$$R10 = R11 \cdot (V_{\text{FLOAT}} - V_{\text{REF}})/V_{\text{REF}}$$

where  $V_{\text{REF}} = 1.225\text{V}$ . The suggested value for R11 is 100k. Use 1% or better resistors.

### Setting DC/DC Converter Output Voltage

From Figure 5, select the following resistors based on output voltage  $V_{\text{REG}}$ :

$$R8 = R14 \cdot (V_{\text{REG}} - V_{\text{REF}})/V_{\text{REF}}$$

where  $V_{\text{REF}} = 1.225\text{V}$ , suggested value for R14 is 100k, 1%.

### LDO Operation

The LTC1980 provides an uninterrupted power supply for the system load. When a wall adapter is connected and operating, power is taken from the wall adapter to charge the batteries and supply power to the system. In applications where an unregulated wall adapter is used but a regulated voltage is needed by the system, an external P-channel MOSFET pass transistor may be added to the LTC1980 to create a low dropout linear regulator.

From Figure 5, select the following resistors based on the output voltage  $V_{\text{LDO}}$ :

$$R5 = R6 \cdot (V_{\text{LDO}} - V_{\text{REF}})/V_{\text{REF}}$$

where  $V_{\text{REF}} = 1.225\text{V}$ , suggested value for R6 is 100k, 1%.

This is the voltage that will be seen when operating from a higher voltage wall adapter. When operating from the batteries (as a regulator), the load will see either this voltage or the voltage set by the PWM regulator, whichever is less, minus any drops in the pass transistor.

Placing a large-valued capacitor from the drain of this MOSFET to ground creates output compensation.

### Wall Adapter Comparator Threshold

From Figure 5, select the following resistors based on the wall adapter comparator threshold  $V_{\text{WATH}}$ :

$$R15 = R7(V_{\text{WATH}} - V_{\text{IH1}})/V_{\text{IH1}}$$

where  $V_{\text{IH1}} = 1.226\text{V}$ , suggested value for R7 is 100k. Use 1% resistors.

### MODE Pin Operation

The following truth table describes MODE pin operation. Burst Mode operation is disabled during battery charging to reduce broadband noise inherent in Burst Mode operation. (Refer to the LT1307 data sheet for details).

POWER FLOW	MODE PIN	OPERATING MODE
Battery Charger	0	Disabled
Battery Charger	Open	Enabled Continuous
Battery Charger	1	Enabled Continuous
DC/DC converter	0	Disabled
DC/DC converter	Open	Enabled Burst Mode Operation
DC/DC converter	1	Enabled Continuous

Logic 1 =  $V_{\text{BIAS1}}$  (Pin 13) Logic 0 = GND

The MODE pin should be decoupled with 200pF to ground when left open.

### Snubber Design

The values given in the applications schematics have been found to work quite well for most applications. Care should be taken in selecting other values for your application since efficiency may be impacted by a poor choice. For a detailed look at snubber design, Application Note 19 is very helpful.

### Frequency Compensation

Load step testing can be used to empirically determine compensation. Application Note 25 provides information on the technique. To adjust the compensation for the DC/DC converter, adjust C12 and R13 (in Figure 5). Battery charger current loop compensation is set by C11 and battery charger float voltage compensation is set by C8.

### Component Selection Basics

The application circuits work well for most 1- and 2-cell Li-Ion, 0.5A to 1A output current designs. The next section highlights the component selection process. More information is available in Application Note 19.

## APPLICATIONS INFORMATION

### Current Sense Resistor

Voltage drop in the current sense resistor should be limited to approximately  $\pm 100\text{mV}$  with respect to ground at max load currents in all modes. This value strikes a reasonable balance between providing an adequate low current signal, while keeping the losses from this resistor low. For applications where the inputs and output voltages may be low, a somewhat lower drop can be used (in order to reduce conduction losses slightly).

The LTC1980 has several features, such as leading-edge blanking, which make application of this part easier to use. However for best charge current accuracy, the current sense resistor should be Kelvin sensed.

### MOSFETs

The LTC1980 uses low side MOSFET switches. There are two very important advantages. First, N-channel MOSFETs are used—this generally means that efficiency will be higher than a comparable on-resistance P-channel device (because less gate charge is required). Second, low  $V_T$  ('logic-level') MOSFETs with relatively low absolute maximum  $V_{GS}$  ratings can be used, even in higher voltage applications. Refer to Application Note 19 for information on determining MOSFET voltage and current ratings.

### Transformer

Turns ratio affects the duty factor of the power converter which impacts current and voltage stress on the power MOSFETs, input and output capacitor RMS currents and transformer utilization (size vs power). Using a 50% duty factor under nominal operating conditions usually gives reasonable results. For a 50% duty factor, the turns ratio is:

$$N = V_{\text{REG}}/V_{\text{BAT}}$$

N should be calculated for the design operating as a DC/DC converter and as a battery charger. The final turns ratio should be chosen so that it is approximately equal to the average of the two calculated values for N. In addition choose a turns ratio which can be made from the ratio of small integers. This allows bifilar windings to be used in

the transformer which can reduce the leakage inductance, reduce the need for aggressive snubber design and for this reason improve efficiency.

*Avoid transformer saturation* under all operating conditions and combinations (usually the biggest problems occur at high output currents and extreme duty cycles. Also *check these conditions for battery charging and regulation modes.*

Finally, in low voltage applications, select a transformer with low winding resistance. This will improve efficiency at heavier loads.

### Capacitors

Check the RMS current rating on your capacitors on both sides of your circuit. Low ESR and ESL is recommended for lowest ripple. OS-CON capacitors (from Sanyo) work very well in this application.

### Diodes

In low voltage applications, Schottky diodes should be placed in parallel with the drain and source of the MOSFETs in the PWM supply. This prevents body diode turn on and improves efficiency by eliminating loss from reverse recovery in these diodes. It also reduces conduction loss during the RGTDR/BGTDR break interval.

The LTC1980 can operate to voltages as low as 2.8V. Suitable Schottky diodes include the ZHCS1000 ( $V_F = 420\text{mV}$  at  $I_F = 1\text{A}$ ) and SL22/23 ( $V_F = 440\text{mV}$  at  $I_F = 2\text{A}$ ) for most 500mA to 1A output current applications.

### Vendor List

VENDOR	COMPONENTS	TELEPHONE
BH Electronics	Transformers	952-894-9590
Coiltronics/Cooper Electronic	Transformers	561-752-5000
Fairchild Semiconductor	MOSFETs Schottky Rectifiers	800-341-0392
Vishay (General Semiconductor)	MOSFETs Schottky Rectifiers	631-847-3000
Sanyo	OS-CON Capacitors	408-749-9714
Sumida Electric USA	Transformers	847-956-0666
Vishay (Siliconix)	MOSFETs	408-988-8000

## TYPICAL APPLICATION

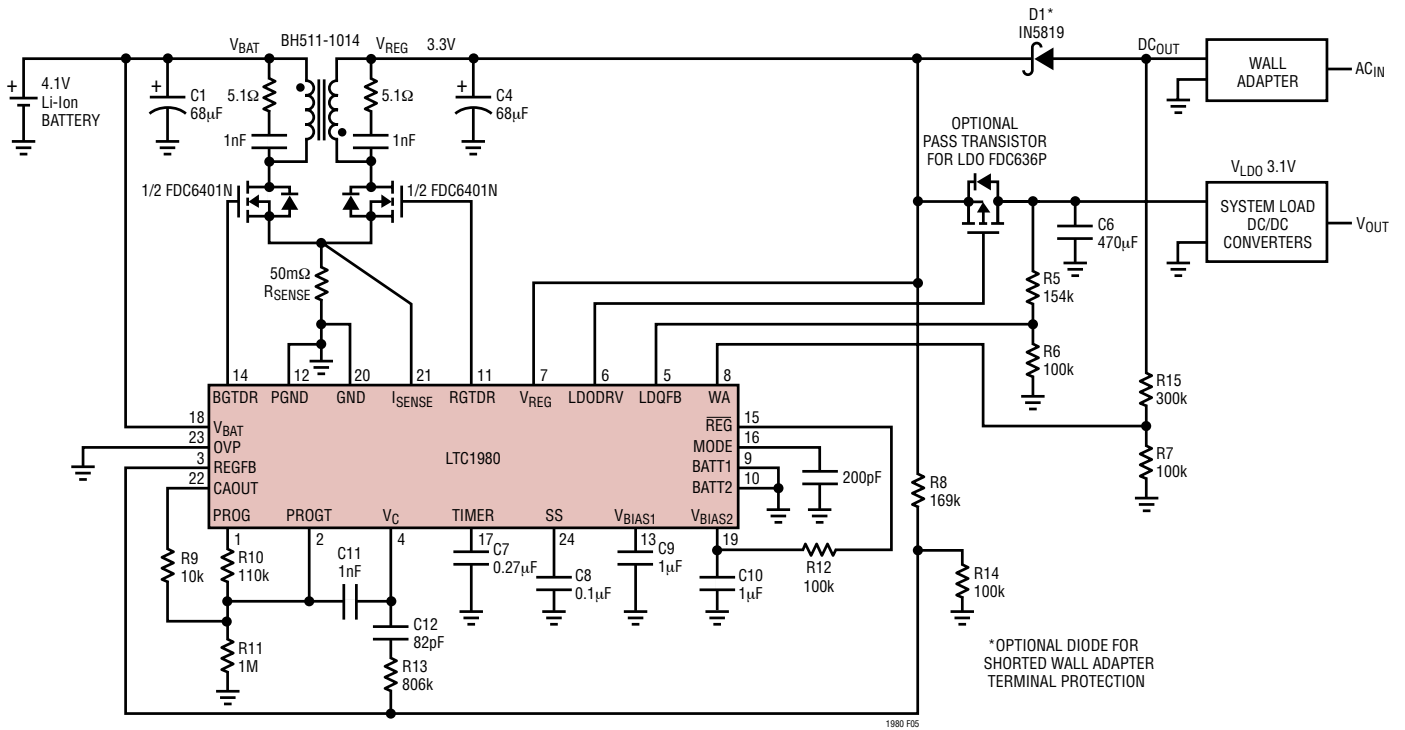
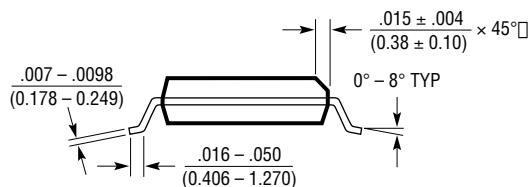
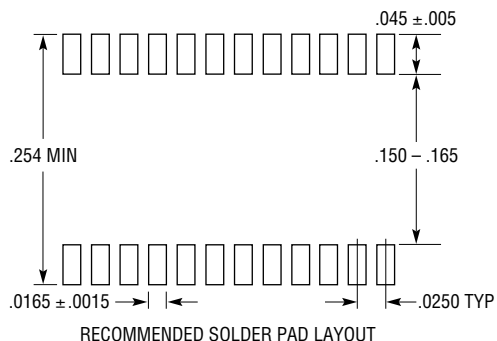

Figure 5. 4.1V/1A Li-Ion Battery Charger and 3.3V DC/DC Converter

# PACKAGE DESCRIPTION

## GN Package 24-Lead Plastic SSOP (Narrow .150 Inch) (Reference LTC DWG # 05-08-1641)



**NOTE:**

1. CONTROLLING DIMENSION: INCHES
  2. DIMENSIONS ARE IN  $\frac{\text{INCHES}}{\text{MILLIMETERS}}$
  3. DRAWING NOT TO SCALE
- \*DIMENSION DOES NOT INCLUDE MOLD FLASH. MOLD FLASH SHALL NOT EXCEED 0.006" (0.152mm) PER SIDE
- \*\*DIMENSION DOES NOT INCLUDE INTERLEAD FLASH. INTERLEAD FLASH SHALL NOT EXCEED 0.010" (0.254mm) PER SIDE

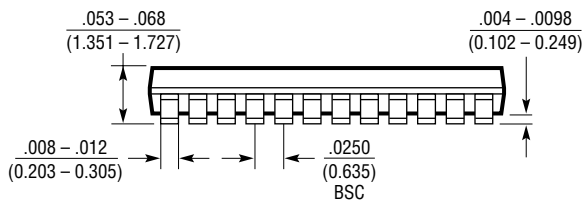
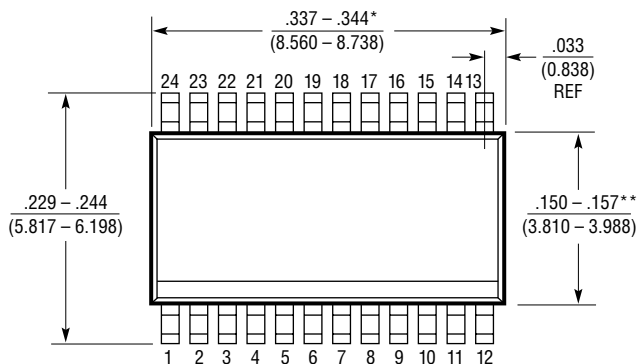

GN24 (SSOP) 0502

**RELATED PARTS**

PART NUMBER	DESCRIPTION	COMMENTS
LT1170/LT1171/LT1172	5A/3A/1.25A Flyback Regulators	Isolated Flyback Mode
LT1571	200kHz/500kHz Switching Battery Charger	Up to 1.5A Charge Current; Preset and Adjustable Battery Voltages
LTC1729	Lithium-Ion Battery Charger Termination Controllers	Time or Charge Current Termination, Preconditioning 8-Lead MSOP
LTC1731	Lithium-Ion Linear Battery Charger Controller	Simple Charger uses External FET, Features Preset Voltages, C/10 Charger Detection and Programmable Timer
LTC1732	Lithium-Ion Linear Battery Charger Controller	Simple Charger uses External FET, Features Preset Voltages, C/10 Charger Detection and Programmable Timer, Input Power Good Indication
LTC1733	Monolithic Lithium-Ion Linear Battery Charger	Standalone Charger with Programmable Timer, Up to 1.5A Charge Current
LTC1734	Lithium-Ion Linear Battery Charger in ThinSOT™	Simple ThinSOT Charger, No Blocking Diode, No Sense Resistor Needed
LTC1734L	Lithium-Ion Linear Battery Charger Controller	50mA to 180mA, No Blocking Diode, No Sense Resistor Needed
LTC1760	Dual Battery Charger/Selector with SMBus Interface	Complete SMBus Charger/Selector for Two Smart Batteries
LTC1960	Dual Battery Charger/Selector with SPI	Complete Dual-Battery Charger/Selector System, Easy Interface with Microcontroller, Extends Run Time by 10%, reduces Charge Time by 50%
LTC4002	Wide $V_{IN}$ Range Li-Ion Battery Charger	1-, 2-Cell Batteries, Switch Mode Charger, Up to $\mu$ A Charge Current, $4.7V \leq V_{IN} \leq 22V$
LTC4007	4A Standalone Multiple Cell Li-Ion Battery Charger	$6V \leq V_{IN} \leq 28V$ , 3- or 4-Cell, Up to 96% Efficiency
LTC4050	Lithium-Ion Linear Battery Charger Controller	Simple Charger uses External FET, Thermistor Input for Battery Temperature Sensing
LTC4052	Lithium-Ion Linear Battery Pulse Charger	Fully Integrated, Standalone Pulse Charger, Minimal Heat Dissipation, Overcurrent Protection
LTC4411	2.6A Low Loss Ideal Diode in ThinSOT	Very Low Loss Replacement for Power Supply ORing Diodes, 2.6V to 5.5V Supply Voltage, ThinSOT Package
LTC4412	Ideal Diode or PowerPath™	Very Low Loss Replacement for Power Supply ORing Diodes, External Pass Element, 3V to 28V Supply Voltage, ThinSOT Package

ThinSOT and PowerPath are trademarks of Linear Technology Corporation.

## Looking for pricing, stock, or lifecycle information?

Click below to explore more details on WIN SOURCE:

 [View LTC1980EGN#PBF on WIN SOURCE](#)

 [Linear Technology](#) Information

## Optimize Your Supply Chain with WIN SOURCE Solutions

-  Global Sourcing Solution
-  Obsolete Management
-  Cost Control Management
-  Shortage Management
-  Alternative Solution
-  Excess Inventory Management