



**THE DATASHEET OF
LTC1732EMS-4.2#PBF**



FEATURES

- Complete Linear Charger Controller for 1-Cell Lithium-Ion Batteries
- Preset Charge Voltage with 1% Accuracy
- Programmable Charge Current
- C/10 Charge Current Detection Output
- Programmable Charge Termination Timer
- Small, Thin 10-Pin MSOP Package
- Select Pin Charges 4.1V or 4.2V Cells (LTC1732-4)
- Input Supply (Wall Adapter) Detection Output
- 4.5V to 12V Input Voltage Range
- Automatic Sleep Mode When Input Supply is Removed (Only 7 μ A Battery Drain)
- Automatic Trickle Charge of Low Voltage Cells
- Programmable for Constant-Current-Only Mode
- Battery Insertion Detect
- 4.05V Recharge Threshold for 4.2V Cells (LTC1732-4.2)
- 3.8V Recharge Threshold for 4.1V or 4.2V Cells (LTC1732-4)

APPLICATIONS

- Cellular Phones
- Handheld Computers
- Charging Docks and Cradles

DESCRIPTION

The LTC[®]1732 is a complete constant-current/constant-voltage linear charger controller for lithium-ion (Li-Ion) batteries. Nickel-cadmium (NiCd) and nickel metal-hydride (NiMH) batteries can also be charged with constant current using external termination. Charge current can be programmed with 7% (max) accuracy using external sense and program resistors. An internal resistor divider and precision reference set the final float voltage with 1% accuracy. The SEL pin allows users to charge either 4.1V or 4.2V cells.

When the input supply is removed, the LTC1732 automatically enters a low current sleep mode, dropping the battery drain current to 7 μ A. An internal comparator detects the end-of-charge (C/10) condition while a programmable timer, using an external capacitor, sets the total charge time. Fully discharged cells are automatically trickle charged at 10% of the programmed current until cell voltage exceeds 2.457V.

The LTC1732 begins a new charge cycle when a discharged battery is connected to the charger or when the input power is applied. In addition, if the battery remains connected to the charger and the cell voltage drops below 3.8V for the LTC1732-4 or below 4.05V for the LTC1732-4.2, a new charge cycle will automatically begin.

The LTC1732 is available in the 10-pin MSOP package.

LT, LTC and LT are registered trademarks of Linear Technology Corporation.

TYPICAL APPLICATION

Single Cell 4.2V Li-Ion Battery Charger

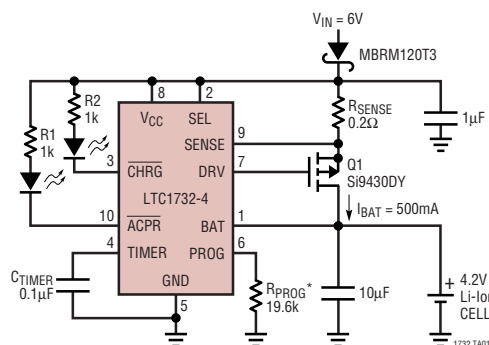

*SHUTDOWN INVOKED BY FLOATING THE PROG PIN

LTC1732-4/LTC1732-4.2

ABSOLUTE MAXIMUM RATINGS

(Note 1)

Input Supply Voltage (V_{CC})	13.2V
SENSE, DRV, BAT, SEL, TIMER, PROG, CHRG, ACPR	-0.3V to 13.2V
Operating Temperature Range (Note 2)	-40° to 85°C
Storage Temperature Range	-65°C to 150°C
Lead Temperature (Soldering, 10 sec)	300°C

PACKAGE/ORDER INFORMATION

<p>MS10 PACKAGE 10-LEAD PLASTIC MSOP $T_{JMAX} = 140^{\circ}\text{C}$, $\theta_{JA} = 180^{\circ}\text{C/W}$</p>	ORDER PART NUMBER
	LTC1732EMS-4 LTC1732EMS-4.2
	MS10 PART MARKING
	LTNJ LTUA

Consult factory for parts specified with wider operating temperature ranges.

ELECTRICAL CHARACTERISTICS

The ● denotes the specifications which apply over the full operating temperature range, otherwise specifications are at $T_A = 25^{\circ}\text{C}$. $V_{CC} = 6\text{V}$ unless otherwise noted.

SYMBOL	PARAMETER	CONDITIONS	MIN	TYP	MAX	UNITS	
V_{CC}	Input Supply Voltage		● 4.5		12	V	
I_{CC}	Input Supply Current	Charger On, Current Mode	●	1	3	mA	
		Shutdown Mode	●	1	3	mA	
		Sleep Mode (Battery Drain Current)		7	20	μA	
V_{BAT}	Regulated Output Voltage	LTC1732-4; $5\text{V} \leq V_{CC} \leq 12\text{V}$, $V_{SEL} = \text{GND}$	● 4.059	4.1	4.141	V	
		LTC1732-4/LTC1732-4.2; $5\text{V} \leq V_{CC} \leq 12\text{V}$, $V_{SEL} = V_{CC}$	● 4.158	4.2	4.242	V	
I_{BAT}	Current Mode Charge Current	$R_{PROG} = 19.6\text{k}$, $R_{SENSE} = 0.2\Omega$	●	465	500	535	mA
		$R_{PROG} = 19.6\text{k}$, $R_{SENSE} = 0.2\Omega$	●	415		585	mA
		$R_{PROG} = 97.6\text{k}$, $R_{SENSE} = 0.2\Omega$		60	100	140	mA
I_{TRIKL}	Trickle Charge Current	$V_{BAT} = 2\text{V}$, $R_{PROG} = 19.6\text{k}$, $I_{TRIKL} = (V_{CC} - V_{SENSE})/0.2\Omega$	●	30	50	110	mA
V_{TRIKL}	Trickle Charge Threshold Voltage	From Low to High	●	2.35	2.457	2.55	V
V_{UV}	V_{CC} Undervoltage Lockout Voltage	From Low to High	●	4.1	4.5		V
ΔV_{UV}	V_{CC} Undervoltage Lockout Hysteresis			200		mV	
V_{MSD}	Manual Shutdown Threshold Voltage	PROG Pin Low to High		2.457		V	
		PROG Pin High to Low		2.446		V	
V_{ASD}	Automatic Shutdown Threshold Voltage	$(V_{CC} - V_{BAT})$ High to Low		30	54	90	mV
		$(V_{CC} - V_{BAT})$ Low to High		40	69	100	mV
V_{DIS}	Voltage Mode Disable Threshold Voltage	$V_{DIS} = V_{CC} - V_{TIMER}$			0.4	V	
I_{PROG}	PROG Pin Current	Internal Pull-Up Current, No R_{PROG}	●	2.5		μA	
		PROG Pin Source Current, $\Delta V_{PROG} \leq 5\text{mV}$			300	μA	
V_{PROG}	PROG Pin Voltage	$R_{PROG} = 19.6\text{k}$		2.457		V	
V_{ACPR}	ACPR Pin Output Low Voltage	$I_{ACPR} = 5\text{mA}$		0.7	1.2	V	
I_{CHRG}	CHRG Pin Weak Pull-Down Current	$V_{CHRG} = 1\text{V}$		15	35	55	μA
V_{CHRG}	CHRG Pin Output Low Voltage	$I_{CHRG} = 5\text{mA}$		0.6	1.2	V	
V_{SEL}	SEL Pin Threshold		●	0.3	2	V	

ELECTRICAL CHARACTERISTICS The ● denotes the specifications which apply over the full operating temperature range, otherwise specifications are at $T_A = 25^\circ\text{C}$. $V_{CC} = 6\text{V}$ unless otherwise noted.

SYMBOL	PARAMETER	CONDITIONS	MIN	TYP	MAX	UNITS
$I_{C/10}$	End of Charge Indication Current Level	$R_{PROG} = 19.6\text{k}\Omega$, $R_{SENSE} = 0.2\Omega$	● 25	50	100	mA
t_{TIMER}	TIMER Accuracy	$C_{TIMER} = 0.1\mu\text{F}$		10		%
V_{RECHRG}	Recharge Battery Voltage Threshold per Cell	V_{BAT} from High to Low (LTC1732-4) V_{BAT} from High to Low (LTC1732-4.2)	3.72	3.80		V
			3.95	4.05		V

Note 1: Absolute Maximum Ratings are those values beyond which the life of a device may be impaired.

Note 2: The LTC1732E is guaranteed to meet performance specifications from 0°C to 70°C . Specifications over the -40°C to 85°C operating temperature range are assured by design, characterization and correlation with statistical process controls.

TYPICAL PERFORMANCE CHARACTERISTICS

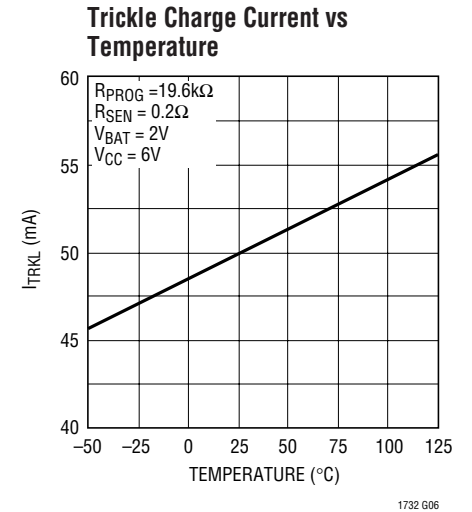
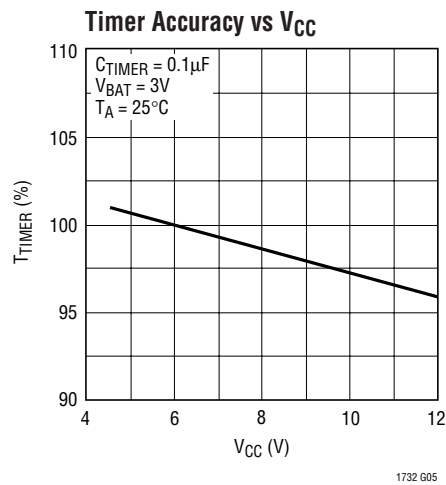
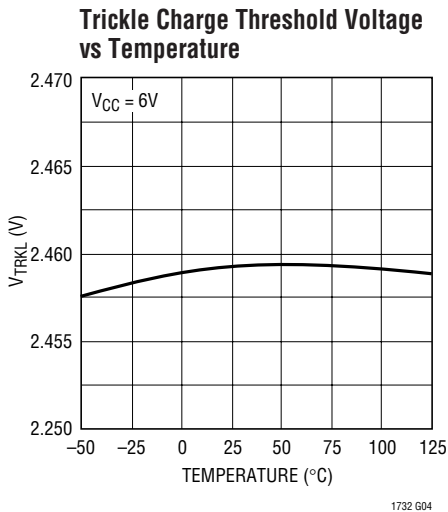
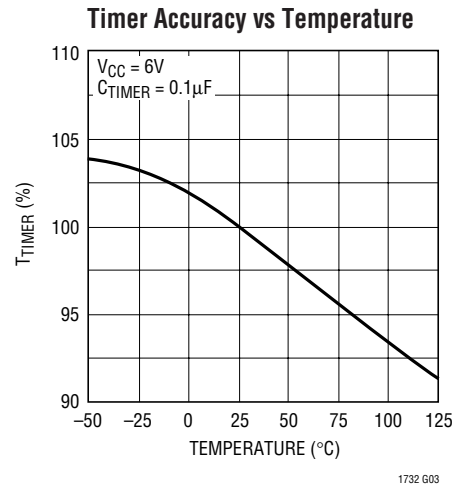
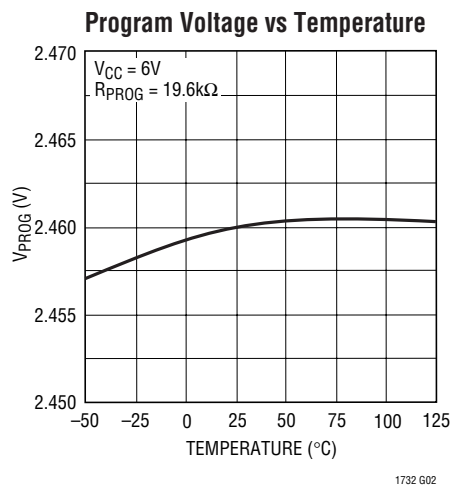
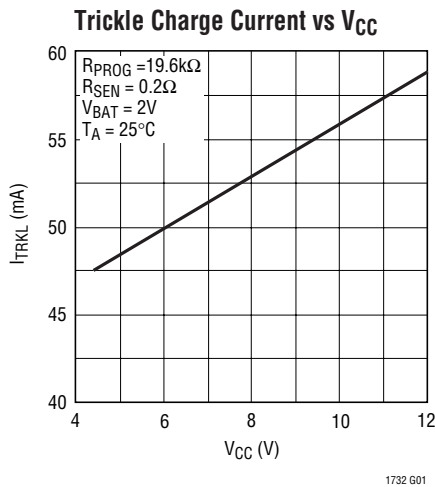

TYPICAL PERFORMANCE CHARACTERISTICS

Battery Charge Current vs Temperature

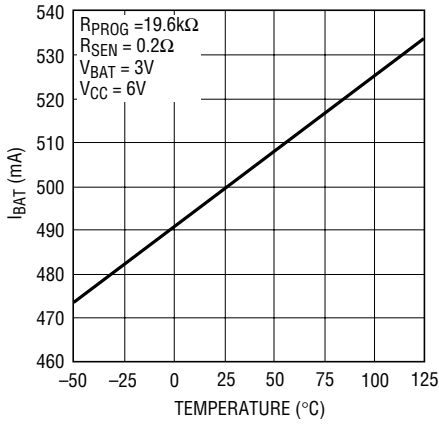

1732 G07

Trickle Charge Threshold Voltage vs VCC

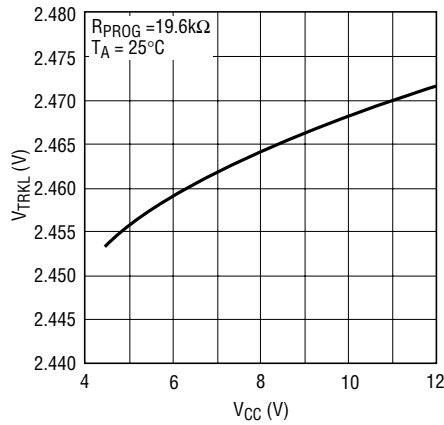

1732 G08

Program Pin Voltage vs VCC

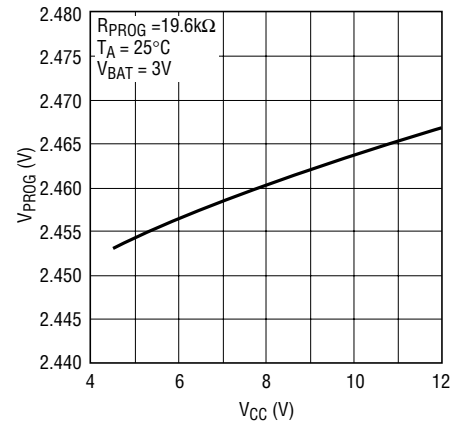

1732 G09

Battery Charge Current vs VCC

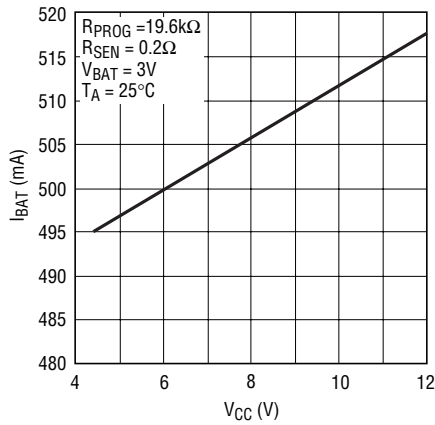

1732 G10

Recharge Threshold Voltage vs Temperature

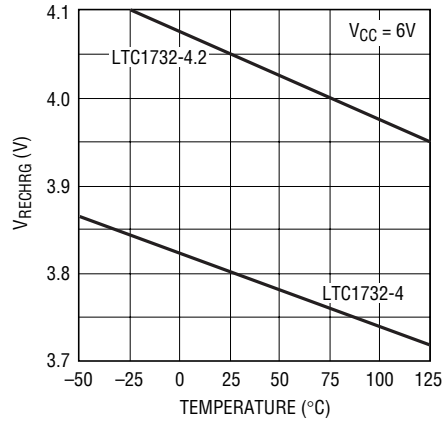

1732 G11

PIN FUNCTIONS

BAT (Pin 1): Battery Sense Input. A bypass capacitor of 10 μ F or more is required to keep the loop stable when the battery is not connected. A precision internal resistor divider on this pin sets the final float potential. The resistor divider is disconnected in sleep mode to reduce the current drain on the battery.

SEL (Pin 2): 4.1V/4.2V Battery Selection Input Pin. Grounding this pin will set the output float voltage to 4.1V per cell, while connecting to V_{CC} will set the voltage to 4.2V per cell. For the LTC1732-4.2, the SEL pin must be connected to V_{CC} .

CHRG (Pin 3): Open-Drain Charge Status Output. When the battery is being charged, the CHRG pin is pulled low by an internal N-channel MOSFET. When the charge current drops to 10% of the full-scale current for more than 15ms, the N-channel MOSFET turns off and a 35 μ A current source is connected from the CHRG pin to GND. When the timer runs out or the input supply is removed, the current source will be disconnected and the CHRG pin is forced into a high impedance state.

TIMER (Pin 4): Timer Capacitor and Constant-Voltage Mode Disable Input Pin. The timer period is set by placing a capacitor, C_{TIMER} , to GND. The timer period is t_{TIMER} (hours) = $(C_{TIMER} \cdot 3 \text{ hours}) / (0.1 \mu\text{F})$. When the TIMER pin is connected to V_{CC} , the timer is disabled, the constant-voltage mode is disabled and the chip will operate in constant-current mode only. Shorting the TIMER pin to GND will disable the internal timer function and the C/10 function.

GND (Pin 5): Ground.

PROG (Pin 6): Charge Current Program and Shutdown Input Pin. The charge current is programmed by connecting a resistor, R_{PROG} to ground. The charge current is $I_{BAT} = (V_{PROG} \cdot 800\Omega) / (R_{PROG} \cdot R_{SENSE})$. The IC can be forced into shutdown by floating the PROG pin and allowing the internal 2.5 μ A current source to pull the pin above the 2.457V shutdown threshold voltage.

DRV (Pin 7): Drive Output Pin for the P-Channel MOSFET or PNP Transistor. If a PNP pass transistor is used, select a high beta transistor to minimize the charge current error due to the base current.

V_{CC} (Pin 8): Positive Input Supply Voltage. When V_{BAT} is within 54mV of V_{CC} , the LTC1732 is forced into sleep mode, dropping I_{CC} to 7 μ A. V_{CC} ranges from 4.5V to 12V. Bypass this pin with a 1 μ F capacitor.

SENSE (Pin 9): Current Sense Input. A sense resistor, R_{SENSE} , must be connected from V_{CC} to the SENSE pin. This resistor is chosen using the following equation:

$$R_{SENSE} = (V_{PROG} \cdot 800\Omega) / (R_{PROG} \cdot I_{BAT})$$

ACPR (Pin 10): Wall Adapter Present Output. When the input voltage (wall adapter) greater than the undervoltage lockout threshold is applied to the LTC1732, this pin is pulled to ground by an internal N-channel MOSFET that is capable of sinking 5mA to drive an external LED.

BLOCK DIAGRAM

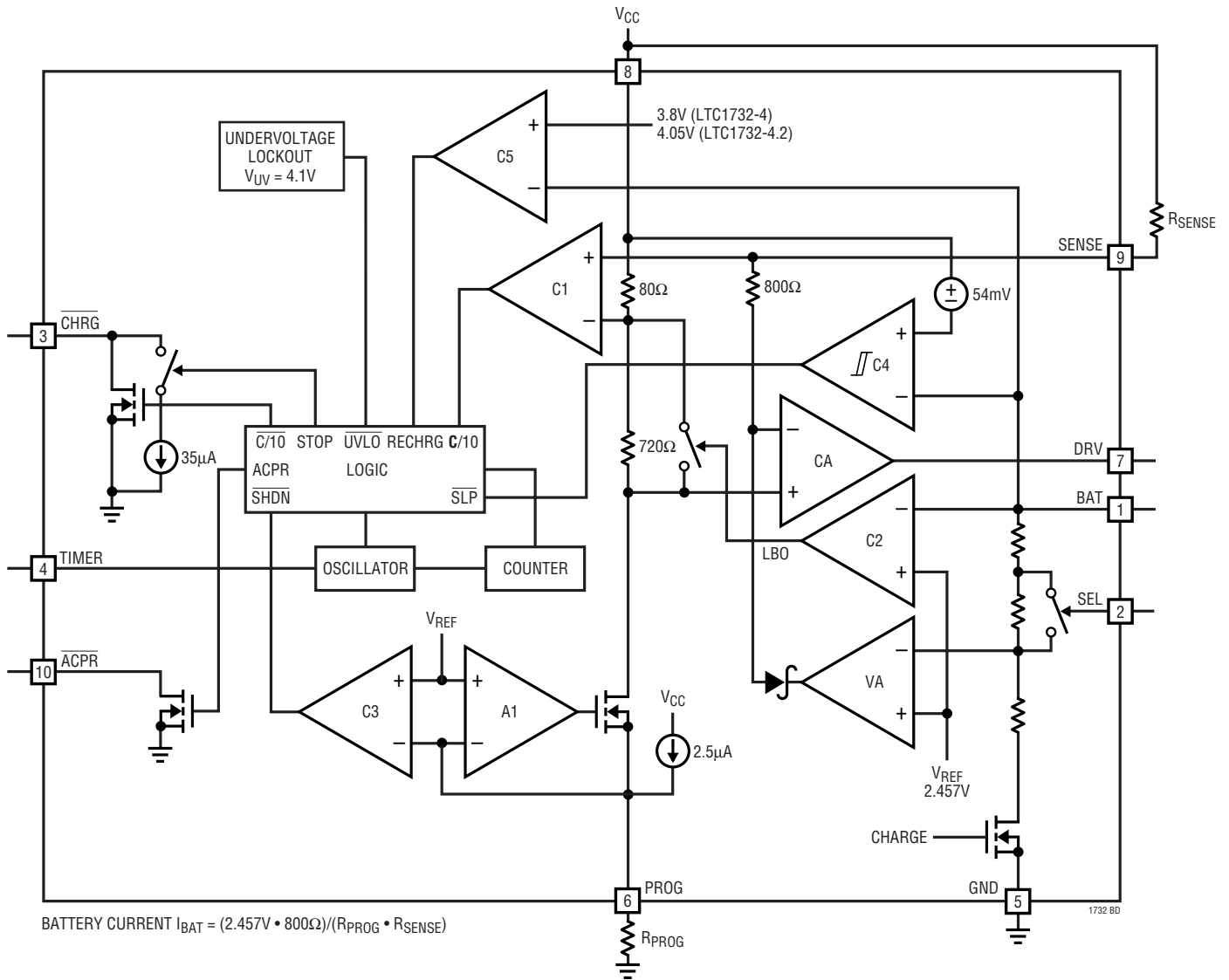

OPERATION

The LTC1732 is a linear battery charger controller. The charge current is programmed by the combination of a program resistor (R_{PROG}) from the PROG pin to ground and a sense resistor (R_{SENSE}) between the V_{CC} and SENSE pins. R_{PROG} sets a program current through an internal trimmed 800Ω resistor setting up a voltage drop from V_{CC} to the input of the current amplifier (CA). The current amplifier servos the gate of the external P-channel MOSFET to force the same voltage drop across R_{SENSE} which sets the charge current. When the potential at the BAT pin approaches the preset float voltage, the voltage amplifier (VA) will start sinking current which shrinks the voltage drop across R_{SENSE} , thus reducing the charge current.

Charging begins when the potential on the V_{CC} pin rises above the UVLO level and a program resistor is connected from the PROG pin to ground. At the beginning of the charge cycle, if the battery voltage is below 2.457V, the charger goes into trickle charge mode. The trickle charge current is 10% of the full-scale current. If the cell voltage stays low for one quarter of the total charge time, the charge sequence will terminate.

The charger goes into the fast charge constant-current mode after the voltage on the BAT pin rises above 2.457V. In constant-current mode, the charge current is set by the combination of R_{SENSE} and R_{PROG} .

When the battery approaches the final float voltage, the charge current will begin to decrease. When the current

drops to 10% of the full-scale charge current, an internal comparator will turn off the pull-down N-channel MOSFET at the $\overline{\text{CHRG}}$ pin and connect a weak current source to ground to indicate an end-of-charge (C/10) condition.

An external capacitor on the TIMER pin sets the total charge time. After a time-out occurs, the charge cycle is terminated and the $\overline{\text{CHRG}}$ pin is forced to a high impedance state. To restart the charge cycle, simply remove the input voltage and reapply it, or float the PROG pin momentarily.

For batteries like lithium-ion that require accurate final float potential, the internal 2.457V reference, voltage amplifier and the resistor divider provide regulation with $\pm 1\%$ (max) accuracy. For NiMH and NiCd batteries, the LTC1732 can function as a current source by pulling the TIMER pin to V_{CC} . When in the constant-current only mode, the voltage amplifier, timer, C/10 comparator and the trickle charge function are all disabled.

The charger can be shut down by floating the PROG pin ($I_{\text{CC}} = 1\text{mA}$). An internal current source will pull this pin high and clamp it at 3.5V.

When the input voltage is not present, the charger goes into a sleep mode, dropping I_{CC} to $7\mu\text{A}$. This greatly reduces the current drain on the battery and increases the standby time.

APPLICATIONS INFORMATION

Charger Conditions

The charger is off when any of the following conditions exist: the V_{CC} pin voltage is less than 4.1V, the dropout voltage ($V_{CC} - V_{BAT}$) is less than 54mV, or if the program resistor is floating. The DRV pin is pulled up to V_{CC} thus keeping the MOSFET off, and the internal resistor divider is disconnected to reduce the drain on the battery.

Undervoltage Lockout (UVLO)

An internal undervoltage lockout circuit monitors the input voltage and keeps the charger in shutdown mode until V_{CC} rises above 4.1V. To prevent oscillation around $V_{CC} = 4.1V$, the UVLO circuit has 200mV of hysteresis.

Trickle Charge and Defective Battery Detection

At the beginning of the charging sequence, if the battery voltage is below 2.457V, the charger goes into trickle mode. The charge current is dropped to 10% of the full-scale current. If the low cell voltage persists for one quarter of the total charging time, the battery is considered defective, the charging will be terminated and the CHRG pin output is forced to a high impedance state.

Shutdown

The LTC1732 can be forced into shutdown by floating the PROG pin and allowing the internal 2.5 μ A current source to pull the pin above the 2.457V shutdown threshold voltage. The DRV pin will then be pulled up to V_{CC} and turn off the external P-channel MOSFET. The internal timer is reset in the shutdown mode.

Programming Charge Current

The formula for the battery charge current (see Block Diagram) is:

$$I_{BAT} = \frac{2.457V}{R_{PROG}} \cdot \frac{800\Omega}{R_{SENSE}}$$

where R_{PROG} is the total resistance from the PROG pin to ground.

For example, if 0.5A charge current is needed, select a value for R_{SENSE} that will drop 100mV at the maximum charge current. $R_{SENSE} = 0.1V/0.5A = 0.2\Omega$, then calculate:

$$R_{PROG} = (2.457V/500mA)(800\Omega/0.2\Omega) = 19.656k$$

For best stability over temperature and time, 1% resistors are recommended. The closest 1% resistor value is 19.6k.

Programming the Timer

The programmable timer is used to terminate the charge cycle. The length of the timer is programmed by an external capacitor at the TIMER pin. The total charge time is:

$$\text{Time} = (3 \text{ Hours})(C_{TIMER}/0.1\mu F)$$

The timer starts when an input voltage greater than 4.1V is applied and the program resistor is connected to ground. After a time-out occurs, the CHRG output will turn into a high impedance state to indicate that the charging has stopped. Connecting the TIMER pin to V_{CC} disables the timer and also puts the charger into a constant-current mode. To disable only the timer function, short the TIMER pin to GND.

Battery Detection and Recharge

LTC1732-4: replacing the battery before the timer has expired will reset the timer, thus starting a new charge cycle, provided the cell voltage of the new battery is less than 3.8V. If the new battery is greater than 3.8V, the timer will not be reset and charging will continue for the remaining portion of the time period. Replacing the battery after the timer has expired will start a new charge cycle, regardless of the battery voltage, provided the previous battery voltage exceeded 3.9V before the timer expired. After a complete charge cycle has occurred ($V_{BAT} > 3.9V$), and the battery remains connected to the charger, a new charge cycle will begin if the battery voltage drops below 3.8V because of a load on the battery or self discharge.

LTC1732-4.2: replacing the battery before the timer has expired will reset the timer, thus starting a new charge cycle, provided the cell voltage of the new battery is less than 4.05V. If the new battery is greater than 4.05V, the timer will not be reset and charging will continue for the remaining portion of the time period. Replacing the battery after the timer has expired will start a new charge cycle, regardless of the battery voltage, provided the previous battery voltage exceeded 4.1V before the timer expired.

APPLICATIONS INFORMATION

After a complete charge cycle has occurred ($V_{BAT} > 4.1V$), and the battery remains connected to the charger, a new charge cycle will begin if the battery voltage drops below 4.05V because of a load on the battery or self discharge.

For either version, to force a new charge cycle, regardless of previous conditions, momentarily lift the program resistor or remove and reapply the input power.

\overline{CHRG} Status Output Pin

When the charge cycle starts, the \overline{CHRG} pin is pulled down to ground by an internal N-channel MOSFET that can drive an LED. When the battery current drops to 10% of the full-scale current ($C/10$), the N-channel MOSFET is turned off and a weak 35 μ A current source to ground is connected to the \overline{CHRG} pin. A 15ms time delay is included to help prevent false triggering due to transient currents. The end-of-charge comparator is disabled in trickle charge mode. After the timer expires, the charge cycle ends, and the pin goes into a high impedance state. The timer is used to terminate the charge cycle. By using two different value pull-up resistors, a microprocessor can detect three states from this pin (charging, $C/10$ and stop charging). See Figure 1.

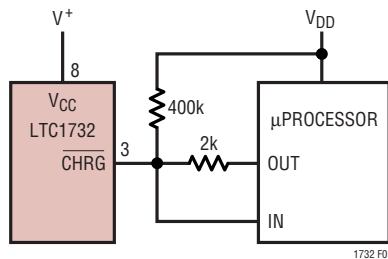

Figure 1. Microprocessor Interface

When the LTC1732 is in charge mode, the \overline{CHRG} pin is pulled low by the internal N-channel MOSFET. To detect this mode, force the digital output pin, OUT, high and measure the voltage at the \overline{CHRG} pin. The N-channel MOSFET will pull the pin low even with a 2k pull-up resistor. Once the charge current drops to 10% of the full-scale current ($C/10$), the N-channel MOSFET is turned off and a 35 μ A current source is connected to the \overline{CHRG} pin. The IN pin will then be pulled high by the 2k pull-up. By

forcing the OUT pin into a high impedance state, the current source will pull the pin low through the 400k resistor. When the internal timer has expired, the \overline{CHRG} pin will change to high impedance state and the 400k resistor will then pull the pin high to indicate the charging has stopped.

\overline{ACPR} Output Pin

The LTC1732 has an \overline{ACPR} output pin to indicate that the input supply (wall adapter) is higher than 4.1V and 54mV above the voltage at the BAT pin. When both conditions are met, the \overline{ACPR} pin is pulled down to ground by an N-channel MOSFET that is capable of driving an LED. Otherwise, this pin is in a high impedance state.

End of Charge ($C/10$) Output

The LTC1732 includes a comparator to monitor the charge current to detect an end-of-charge condition. This comparator does not terminate the charge cycle, but provides an output signal to indicate a near full charge condition. The timer is used to terminate the charge cycle. When the battery current falls below 10% of full scale, the comparator trips and turns off the N-channel MOSFET at the \overline{CHRG} pin and switches in a 35 μ A current source to ground. A 15ms time delay is included to help prevent false triggering due to transient currents. The end-of-charge comparator is disabled in trickle charge mode.

Output Voltage Selection

The float voltage at the BAT pin can be selected by the SEL pin. Shorting the SEL pin to ground will set the float voltage to 4.1V, while connecting it to V_{CC} sets it to 4.2V. This feature allows the charger to be used with different types of Li-Ion cells. When charging 4.1V cells, use the LTC1732-4 with the SEL pin grounded. The LTC1732-4 can also be used for charging 4.2V cells by connecting the SEL pin to V_{CC} . The recharge threshold level is preset to 3.8V, thus allowing either 4.1V or 4.2V cells to be charged. Because the recharge threshold voltage level of the LTC1732-4.2 is preset for 4.05V, this version is *not* recommended for 4.1V cells.

APPLICATIONS INFORMATION

Gate Drive

Typically the LTC1732 controls an external P-channel MOSFET to supply current to the battery. An external PNP transistor can also be used as the pass transistor instead of the P-channel MOSFET. Due to the low transconductance of the current amplifier (CA), a high gain Darlington PNP transistor is required to avoid excessive charge current error. The transconductance of the current amplifier is around $0.6\mu\text{A}/\text{mV}$. For every $1\mu\text{A}$ of base current, a 1.6mV of gain error shows up at the inputs of CA. With $R_{\text{PROG}} = 19.6\text{k}$ (100mV across R_{SENSE}). This represents a 1.6% error in charge current.

Constant-Current Only Mode

The LTC1732 can be used as a programmable current source by connecting the TIMER pin to V_{CC} . This is particularly useful for charging NiMH or NiCd batteries. In the constant-current only mode, the timer and voltage

amplifier are both disabled. An external termination method is required to properly terminate the charging by floating the PROG pin.

Stability

The charger is stable without any compensation when a P-channel MOSFET is used as the pass transistor and the battery is present. A $10\mu\text{F}$ tantalum capacitor is recommended at the BAT pin to keep the ripple voltage low when the battery is disconnected. A ceramic output capacitor may also be used, but because of the very low ESR and high Q characteristics of multilayer ceramic capacitors, it may be necessary to add a 1Ω resistor in series with the ceramic capacitor to improve voltage mode stability.

If a PNP transistor is used for the pass transistor, a 1000pF capacitor is required from the DRV pin to V_{CC} . To help stabilize the voltage loop a $10\mu\text{F}$ tantalum capacitor at the BAT pin is also recommended when a battery is not present.

TYPICAL APPLICATIONS

Li-Ion Linear Charger Using a PNP Transistor

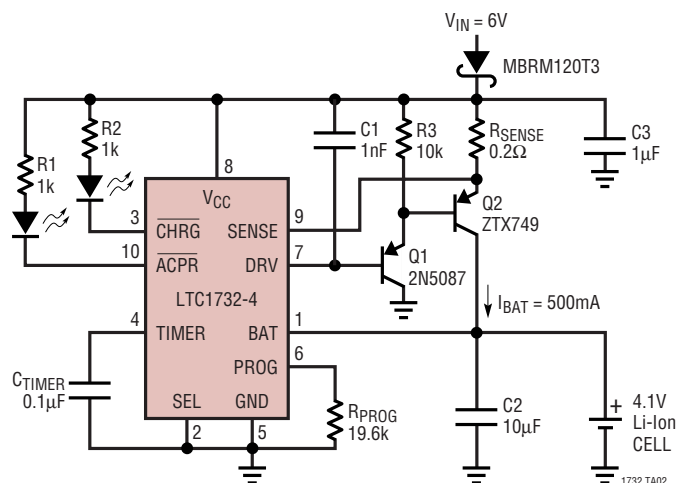

PACKAGE DESCRIPTION Dimensions in inches (millimeters) unless otherwise noted.

MS10 Package
10-Lead Plastic MSOP
 (LTC DWG # 05-08-1661)

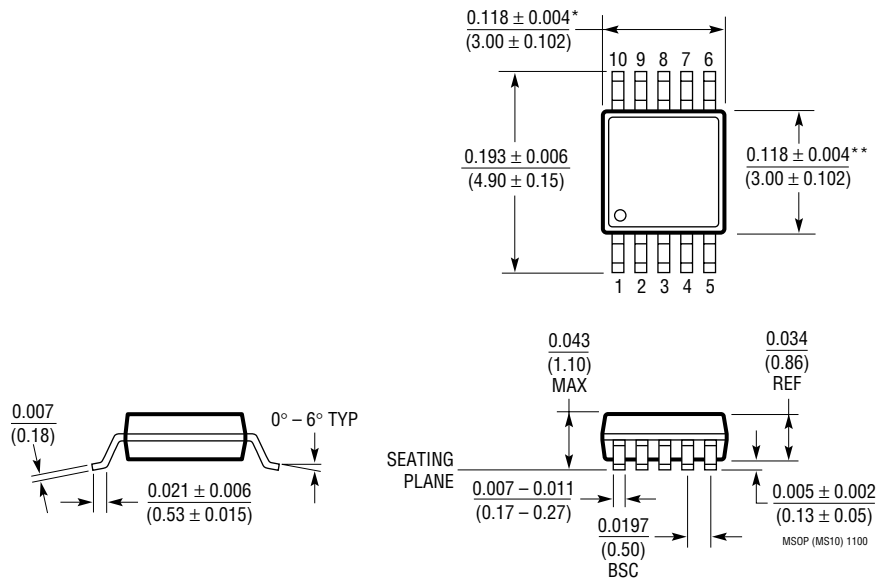

- * DIMENSION DOES NOT INCLUDE MOLD FLASH, PROTRUSIONS OR GATE BURRS. MOLD FLASH, PROTRUSIONS OR GATE BURRS SHALL NOT EXCEED 0.006* (0.152mm) PER SIDE
- ** DIMENSION DOES NOT INCLUDE INTERLEAD FLASH OR PROTRUSIONS. INTERLEAD FLASH OR PROTRUSIONS SHALL NOT EXCEED 0.006* (0.152mm) PER SIDE

Looking for pricing, stock, or lifecycle information?

Click below to explore more details on WIN SOURCE:

 [View LTC1732EMS-4.2#PBF on WIN SOURCE](#)

 [Linear Technology](#) Information

Optimize Your Supply Chain with WIN SOURCE Solutions

-  Global Sourcing Solution
-  Obsolete Management
-  Cost Control Management
-  Shortage Management
-  Alternative Solution
-  Excess Inventory Management