

ABSOLUTE MAXIMUM RATINGS

(Note 1)

V_{CC} to GND	-0.5V to 7.5V
TTL Input Voltage, REFHI, REFLO, $X_1/X_{1/2}$	-0.5V to 7.5V
V_{OUT} , SDO	-0.5V to ($V_{CC} + 0.5V$)
Operating Temperature Range	
LTC1654C	0°C to 70°C
LTC1654I	-40°C to 85°C
Maximum Junction Temperature	125°C
Storage Temperature Range	-65°C to 150°C
Lead Temperature (Soldering, 10 sec)	300°C

PACKAGE/ORDER INFORMATION

<p>TOP VIEW</p> <p>GN PACKAGE 16-LEAD PLASTIC SSOP $T_{JMAX} = 125^{\circ}C$, $\theta_{JA} = 110^{\circ}C/W$</p>	ORDER PART NUMBER
	LTC1654CGN LTC1654IGN
	GN PART MARKING
	1654 1654I

Order Options Tape and Reel: Add #TR
 Lead Free: Add #PBF Lead Free Tape and Reel: Add #TRPBF
 Lead Free Part Marking: <http://www.linear.com/leadfree/>

Consult LTC Marketing for parts specified with wider operating temperature ranges.

ELECTRICAL CHARACTERISTICS The ● denotes specifications which apply over the full operating temperature range, otherwise specifications are at $T_A = 25^{\circ}C$. Unless otherwise noted, $V_{CC} = 2.7V$ to $5.5V$, $V_{OUT A}$, $V_{OUT B}$ unloaded, REFHI A, REFHI B = 4.096V ($V_{CC} = 5V$), REFHI A, REFHI B = 2.048V ($V_{CC} = 2.7V$), REFLO = 0V, $X_1/X_{1/2} = 0V$.

SYMBOL	PARAMETER	CONDITIONS	MIN	TYP	MAX	UNITS
DAC						
n	Resolution		●	14		Bits
	Monotonicity		●	14		Bits
DNL	Differential Nonlinearity	Guaranteed Monotonic (Note 2)	●	±0.3	±1	LSB
INL	Integral Nonlinearity	Integral Nonlinearity (Note 2)	●	±1.2	±4	LSB
ZSE	Zero Scale Error	0°C ≤ T_A ≤ 70°C -40°C ≤ T_A ≤ 85°C	●	0	6.5	mV
			●		9.0	mV
V_{OS}	Offset Error	0°C ≤ T_A ≤ 70°C (Note 3) -40°C ≤ T_A ≤ 85°C (Note 3)	●		±6.5	mV
			●		±9.0	mV
$V_{OS}TC$	Offset Error Tempco			±15		μV/°C
	Gain Error		●		±24	LSB
	Gain Error Drift			5		ppm/°C
Power Supply						
V_{CC}	Positive Supply Voltage	For Specified Performance	●	2.7	5.5	V
I_{CC}	Supply Current (SLOW/FAST)	2.7V ≤ V_{CC} ≤ 5.5V (Note 5) SLOW	●		540	μA
		2.7V ≤ V_{CC} ≤ 5.5V (Note 5) FAST	●		930	μA
		2.7V ≤ V_{CC} ≤ 3.3V (Note 5) SLOW	●		350	μA
		2.7V ≤ V_{CC} ≤ 3.3V (Note 5) FAST	●		680	μA
		In Shutdown (Note 5)	●		3	μA
					10	μA
Op Amp DC Performance						
	Short-Circuit Current Low	V_{OUT} Shorted to GND	●	70	120	mA
	Short-Circuit Current High	V_{OUT} Shorted to V_{CC}	●	80	120	mA
	Output Impedance to GND	Input Code = 0	●	40	200	Ω
PSR	Power Supply Rejection	REFHIA, REFHIB = 4.096V ($V_{CC} = 5V \pm 10\%$) REFHIA, REFHIB = 2.048V ($V_{CC} = 3V \pm 10\%$) Input Code = 16383	●		2.5	mV/V

ELECTRICAL CHARACTERISTICS The ● denotes specifications which apply over the full operating temperature range, otherwise specifications are at $T_A = 25^\circ\text{C}$. Unless otherwise noted, $V_{CC} = 2.7\text{V}$ to 5.5V , $V_{OUT A}$, $V_{OUT B}$ unloaded, REFHI A, REFHI B = 4.096V ($V_{CC} = 5\text{V}$), REFHI A, REFHI B = 2.048V ($V_{CC} = 2.7\text{V}$), REFLO = 0V , $X_1/X_{1/2} = 0\text{V}$.

SYMBOL	PARAMETER	CONDITIONS		MIN	TYP	MAX	UNITS
AC Performance							
	Voltage Output Slew Rate	(Note 8) SLOW (Note 8) FAST	● ●	0.20 1.25	0.9 3.8		$\text{V}/\mu\text{s}$ $\text{V}/\mu\text{s}$
	Voltage Output Settling Time	(Note 4) to $\pm 1\text{LSB}$, SLOW (Note 4) to $\pm 1\text{LSB}$, FAST			8.5 3.0		μs μs
	Digital Feedthrough	(Note 7)			1		$\text{nV}\cdot\text{s}$
	Midscale Glitch Impulse	DAC Switch Between 8000 and 7FFF			20		$\text{nV}\cdot\text{s}$
	Output Noise Voltage Density	at 10kHz, SLOW at 10kHz, FAST			170 150		$\text{nV}/\sqrt{\text{Hz}}$ $\text{nV}/\sqrt{\text{Hz}}$
Digital I/O							
V_{IH}	Digital Input High Voltage	$V_{CC} = 5\text{V}$	●	2.4			V
V_{IL}	Digital Input Low Voltage	$V_{CC} = 5\text{V}$	●			0.8	V
V_{OH}	Digital Output High Voltage	$V_{CC} = 5\text{V}$, $I_{OUT} = -1\text{mA}$, D_{OUT} Only	●	$V_{CC} - 0.4$			V
V_{OL}	Digital Output Low Voltage	$V_{CC} = 5\text{V}$, $I_{OUT} = 1\text{mA}$, D_{OUT} Only	●			0.4	V
V_{IH}	Digital Input High Voltage	$V_{CC} = 3\text{V}$	●	2.4			V
V_{IL}	Digital Input Low Voltage	$V_{CC} = 3\text{V}$	●			0.8	V
V_{OH}	Digital Output High Voltage	$V_{CC} = 3\text{V}$, $I_{OUT} = -1\text{mA}$, D_{OUT} Only	●	$V_{CC} - 0.4$			V
V_{OL}	Digital Output Low Voltage	$V_{CC} = 3\text{V}$, $I_{OUT} = 1\text{mA}$, D_{OUT} Only	●			0.4	V
I_{LEAK}	Digital Input Leakage	$V_{IN} = \text{GND}$ to V_{CC}	●			± 10	μA
C_{IN}	Digital Input Capacitance	(Note 6)				10	pF
Reference Input							
	Reference Input Resistance	REFHI to REFLO	●	30	60		$\text{k}\Omega$
	Reference Input Range	(Note 6)	●	0		V_{CC}	V
	Reference Input Current	In Shutdown	●			1	μA
Switching Characteristics ($V_{CC} = 4.5\text{V}$ to 5.5V)							
t_1	SDI Valid to SCK Setup		●	30			ns
t_2	SDI Valid to SCK Hold	(Note 6)	●	0			ns
t_3	SCK High Time	(Note 6)	●	15			ns
t_4	SCK Low Time	(Note 6)	●	15			ns
t_5	$\overline{\text{CS}}/\text{LD}$ Pulse Width	(Note 6)	●	15			ns
t_6	LSB SCK to $\overline{\text{CS}}/\text{LD}$	(Note 6)	●	10			ns
t_7	$\overline{\text{CS}}/\text{LD}$ Low to SCK	(Note 6)	●	10			ns
t_8	SD0 Output Delay	$C_{LOAD} = 100\text{pF}$	●	5		100	ns
t_9	SCK Low to $\overline{\text{CS}}/\text{LD}$ Low	(Note 6)	●	10			ns
t_{10}	$\overline{\text{CLR}}$ Pulse Width	(Note 6)	●	30			ns
Switching Characteristics ($V_{CC} = 2.7\text{V}$ to 5.5V)							
t_1	SDI Valid to SCK Setup		●	45			ns
t_2	SDI Valid to SCK Hold	(Note 6)	●	0			ns
t_3	SCK High Time	(Note 6)	●	20			ns
t_4	SCK Low Time	(Note 6)	●	20			ns
t_5	$\overline{\text{CS}}/\text{LD}$ Pulse Width	(Note 6)	●	20			ns
t_6	LSB SCK to $\overline{\text{CS}}/\text{LD}$	(Note 6)	●	15			ns
t_7	$\overline{\text{CS}}/\text{LD}$ Low to SCK	(Note 6)	●	15			ns

ELECTRICAL CHARACTERISTICS

The ● denotes specifications which apply over the full operating temperature range, otherwise specifications are at $T_A = 25^\circ\text{C}$. Unless otherwise noted, $V_{CC} = 2.7\text{V}$ to 5.5V , $V_{OUT A}$, $V_{OUT B}$ unloaded, REFHI A, REFHI B = 4.096V ($V_{CC} = 5\text{V}$), REFHI A, REFHI B = 2.048V ($V_{CC} = 2.7\text{V}$), REFLO = 0V , $X_1/X_{1/2} = 0\text{V}$.

SYMBOL	PARAMETER	CONDITIONS	MIN	TYP	MAX	UNITS
Switching Characteristics ($V_{CC} = 2.7\text{V}$ to 5.5V)						
t_8	SDO Output Delay	$C_{LOAD} = 100\text{pF}$	●	5	150	ns
t_9	SCK Low to $\overline{\text{CS}}/\text{LD}$ Low	(Note 6)	●	15		ns
t_{10}	$\overline{\text{CLR}}$ Pulse Width	(Note 6)	●	45		ns

Note 1: Absolute Maximum Ratings are those values beyond which the life of a device may be impaired.

Note 2: Nonlinearity is defined from low code k_L to code 16383. See Applications Information (page 11).

Note 3: Offset error is measured at low code k_L . See Applications Information (page 11).

Note 4: DAC switched between code 2 k_L and code 16383. See Applications Information (page 11) for definition of low code k_L .

Note 5: Digital inputs at 0V or V_{CC} .

Note 6: Guaranteed by design.

Note 7: $\overline{\text{CS}}/\text{LD} = 0$, $V_{OUT} = 4.096\text{V}$ and data is being clocked in.

Note 8: 100pF load capacitor.

TYPICAL PERFORMANCE CHARACTERISTICS

Integral Nonlinearity (INL) vs Input Code

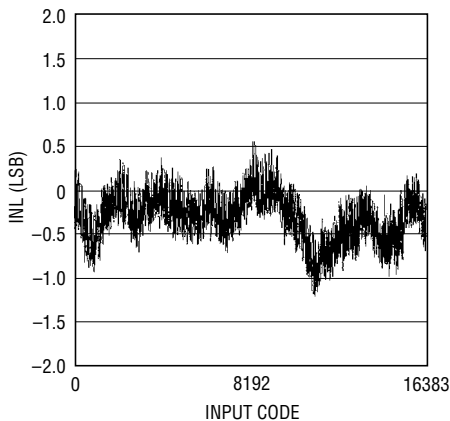

Differential Nonlinearity (DNL) vs Input Code

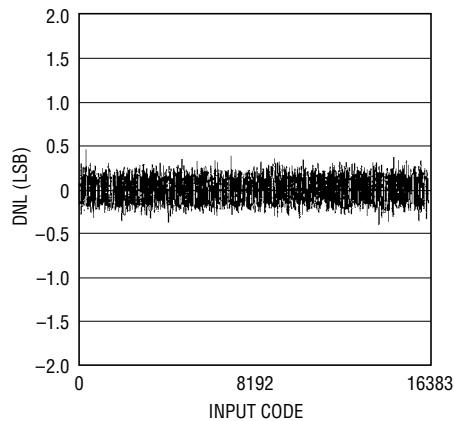

Offset vs Temperature

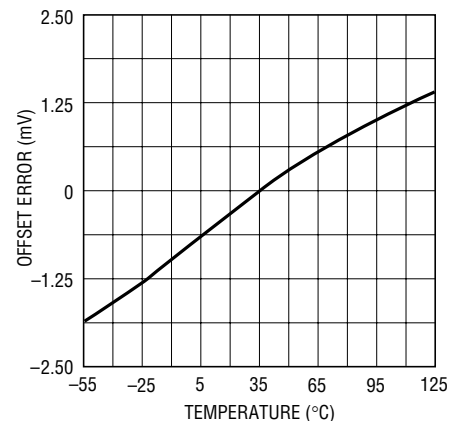

Gain Error vs Temperature

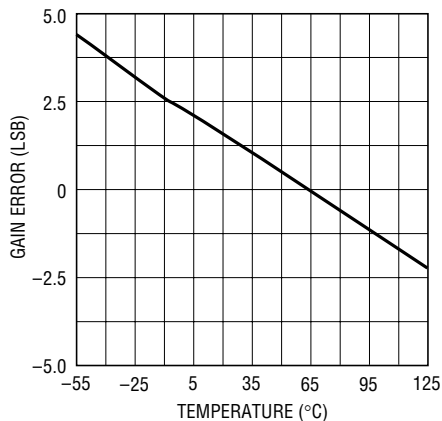

Minimum Output Voltage vs Load Current (Output Sinking)

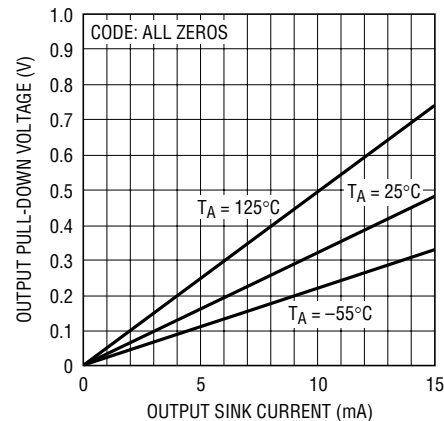

Minimum Supply Headroom vs Load Current (Output Sourcing)

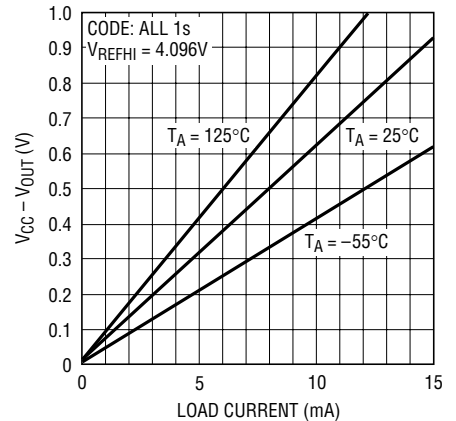

TYPICAL PERFORMANCE CHARACTERISTICS

Supply Current vs Logic Input Voltage

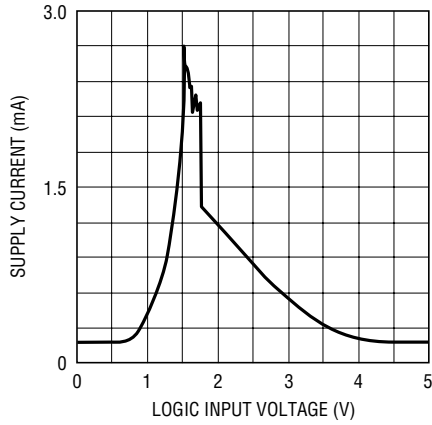

1654 G07

Large-Signal Settling—Fast Mode

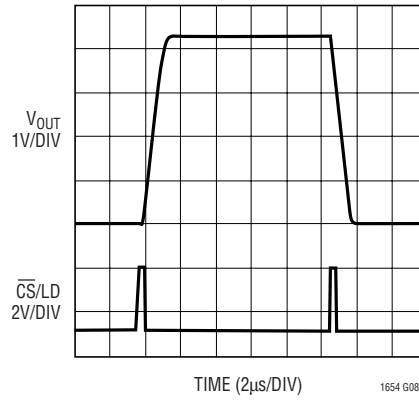

1654 G08

Large-Signal Settling—Slow Mode

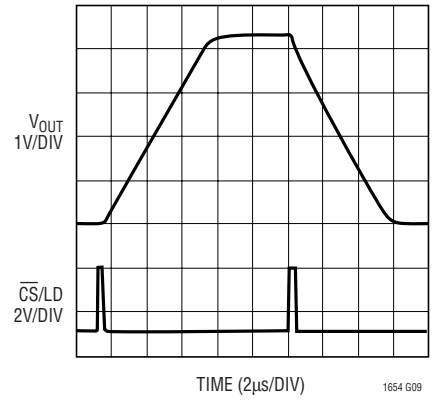

1654 G09

Midscale Glitch—Fast Mode

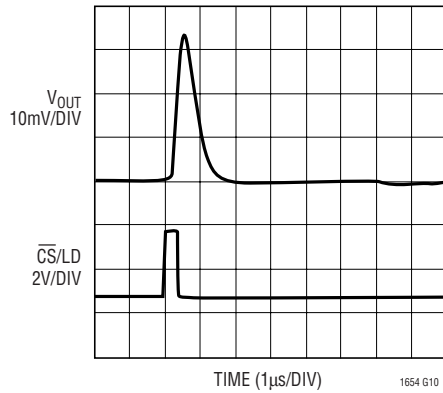

1654 G10

Midscale Glitch—Slow Mode

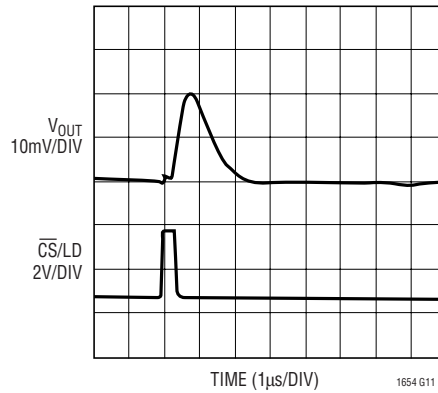

1654 G11

VOUT Glitch at Power-Up

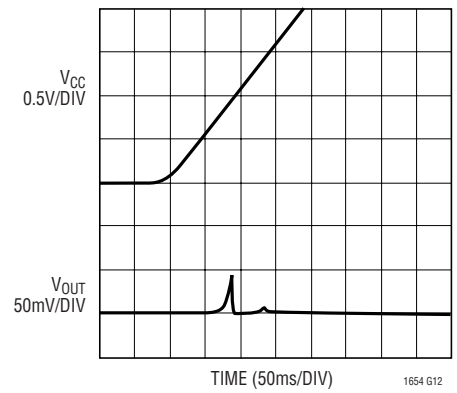

1654 G12

PIN FUNCTIONS

X₁/X_{1/2} B, X₁/X_{1/2} A (Pins 1, 8): The Gain of 1 or Gain of 1/2 Pin. When this pin is tied to V_{OUT}, the output range will be REFLO to (REFLO + REFHI)/2 (0V to REFHI/2 when REFLO = 0V). When this pin is tied to REFLO, the output range will be REFLO to REFHI (0V to REFHI when REFLO = 0V). These pins should not be left floating.

CLR (Pin 2): The Asynchronous Clear Input.

SCK (Pin 3): The TTL Level Input for the Serial Interface Clock.

SDI (Pin 4): The TTL Level Input for the Serial Interface Data. Data on the SDI pin is latched into the shift register on the rising edge of the serial clock. The LTC1654 allows either a 24-bit or 32-bit word. When a 24-bit word is used, the first 8 bits are control and address followed by 16 data bits. The last two of the 16 data bits are don't cares. When a 32-bit word (required for daisy-chain operation) is used, the first 8-bits are don't cares and the following 24-bits are as above.

CS/LD (Pin 5): The TTL Level Input for the Serial Interface Enable and Load Control. When CS/LD is low, the SCK signal is enabled, so the data can be clocked in. When CS/LD is pulled high, the control/address bits are decoded.

DGND/AGND (Pins 6, 12): Digital and Analog Grounds.

SDO (Pin 7): The output of the shift register that becomes valid on the rising edge of the serial clock.

V_{OUT A/B} (Pins 9, 15): The Buffered DAC Outputs.

REFHI A/B (Pins 10, 14): The Reference High Inputs of the LTC1654. There is a gain of 1 from this pin to the output in a gain of 1 configuration. In a gain of 1/2 configuration, there is a gain of 1/2 from this pin to V_{OUT}.

REFLO A/B (Pins 11, 13): The Reference Low Inputs of the LTC1654. These inputs can swing up to V_{CC} – 1.5V.

V_{CC} (Pin 16): The Positive Supply Input. 2.7V ≤ V_{CC} ≤ 5.5V. Requires a 0.1μF bypass capacitor to ground.

TIMING DIAGRAMS

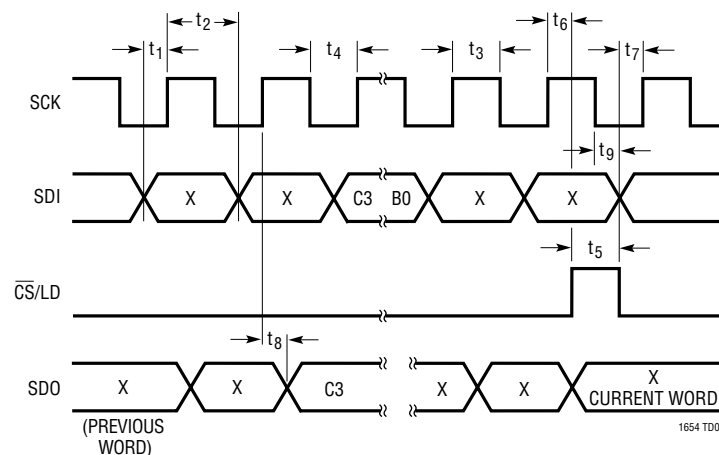

TIMING DIAGRAMS

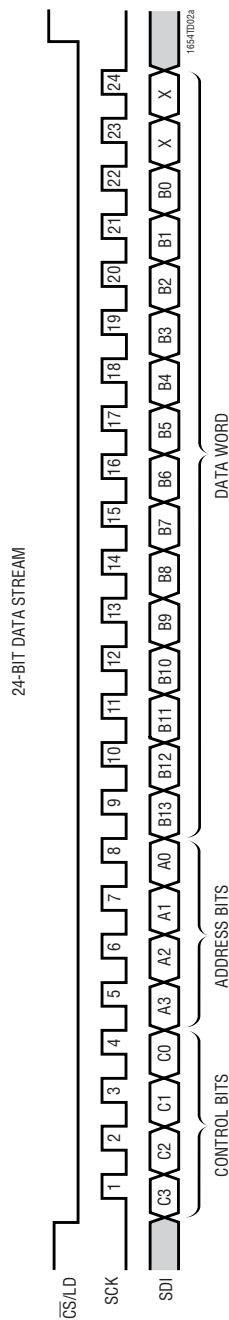

Figure 1a. 24-Bit Load Sequence (for Non-Daisy-Chained Applications)

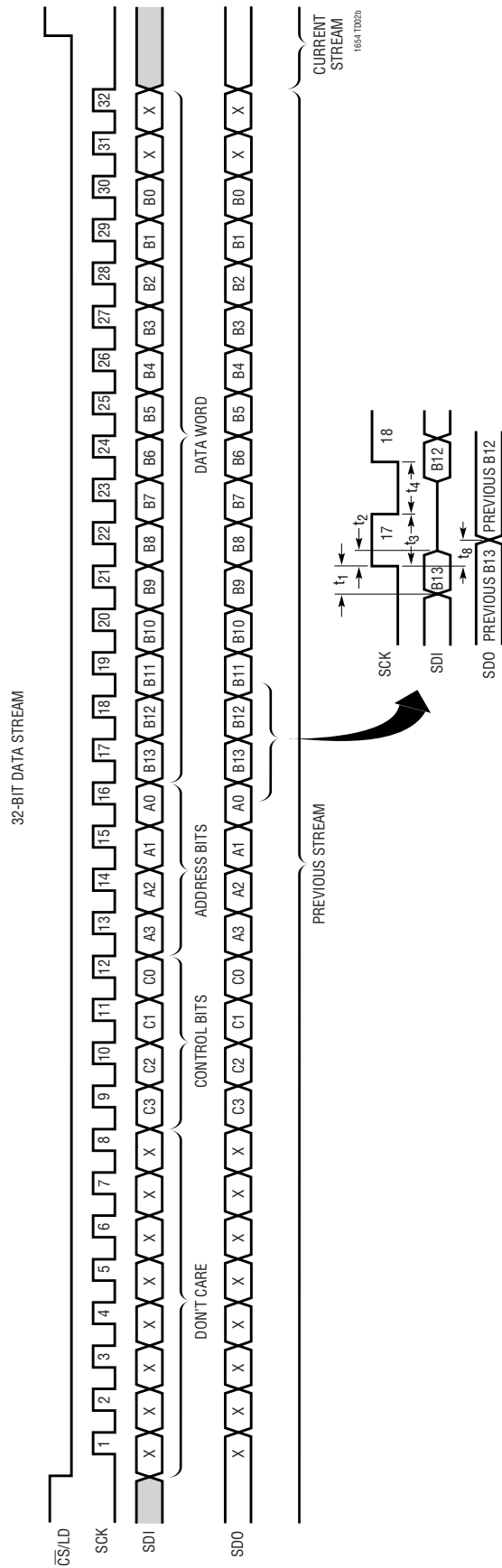

Figure 1b. 32-Bit Load Sequence (for Single and Daisy-Chained LTC1654s)

OPERATION

Serial Interface

The data on the SDI input is loaded into the shift register on the rising edge of SCK. The MSB is loaded first. The Clock is disabled internally when $\overline{\text{CS/LD}}$ is high. Note: SCK must be low before $\overline{\text{CS/LD}}$ is pulled low to avoid an extra internal clock pulse.

If no daisy-chaining is required, the input word can be 24-bit wide, as shown in the timing diagrams. The 8 MSBs, which are loaded first, are the control and address bits followed by a 16-bit data word. The last two LSBs in the data word are don't cares. The input word can be a stream of three 8-bit wide segments as shown in the "24-Bit Update" timing diagram.

If daisy-chaining is required or if the input needs to be written in two 16-bit wide segments, then the input word can be 32 bits wide and the top 8 bits (MSBs) are don't cares. The remaining 24 bits are control/address and data. This is also shown in the timing diagrams. The buffered output of the internal 32-bit shift register is available on the SDO pin, which swings from GND to V_{CC} .

Multiple LTC1654s may be daisy-chained together by connecting the SDO pin to the SDI pin of the next IC. The SCK and $\overline{\text{CS/LD}}$ signals remain common to all ICs in the daisy-chain. The serial data is clocked to all of the chips, then the $\overline{\text{CS/LD}}$ signal is pulled high to update all DACs simultaneously.

Table 1 shows the truth table for the control/address bits. When the supplies are first applied, the LTC1654 uses SLOW mode, the outputs are set at 0V, and zeros are loaded into the 32-bit input shift register. About 300ns after power-up, the outputs are released from 0V (AGND) and will go to the voltage on the REFLO pin.

When $\overline{\text{CLR}}$ goes active, zeros are loaded into the input and DAC latch and the outputs are forced to AGND. After $\overline{\text{CLR}}$ is forced high, the outputs will go to the voltage on the REFLO pin.

Three examples are given to illustrate the DAC's operation:

1. **Load and update DAC A in FAST mode. Leave DAC B unchanged.** Perform the following sequence for the control, address and DATA bits:

Step 1: Set DAC A in FAST mode

$\overline{\text{CS/LD}}$ \downarrow clock in 0101 0000 XXXXXXXX XXXXXXXX;
 $\overline{\text{CS/LD}}$ \uparrow

Step 2: Load and update DAC A with DATA

$\overline{\text{CS/LD}}$ \downarrow clock in 0011 0000 + DATA; $\overline{\text{CS/LD}}$ \uparrow

2. **Load and update DAC A in SLOW mode. Power down DAC B.** Perform the following sequence for the control, address and DATA bits:

Step 1: Set DAC A in SLOW mode

$\overline{\text{CS/LD}}$ \downarrow clock in 0110 0000 XXXXXXXX
XXXXXXXX;
 $\overline{\text{CS/LD}}$ \uparrow

Step 2: Load and update DAC A with DATA

$\overline{\text{CS/LD}}$ \downarrow clock in 0011 0000 + DATA; $\overline{\text{CS/LD}}$ \uparrow

Step 3: Power down DAC B

$\overline{\text{CS/LD}}$ \downarrow clock in 0100 0001 XXXXXXXX
XXXXXXXX;
 $\overline{\text{CS/LD}}$ \uparrow

3. **Power down both DACs at the same time.** Perform the following sequence for the control, address and DATA bits:

Step 1: Power down both DACs simultaneously

$\overline{\text{CS/LD}}$ \downarrow clock in 0100 1111 XXXXXXXX
XXXXXXXX;
 $\overline{\text{CS/LD}}$ \uparrow

OPERATION

Voltage Output

The LTC1654 comes complete with rail-to-rail voltage output buffer amplifiers. These amplifiers will swing to within a few millivolts of either supply rail when unloaded and to within a 450mV of either supply rail when sinking or sourcing 5mA.

There are two GAIN configuration modes for the LTC1654:

- a) GAIN of 1: ($X_1/X_{1/2}$ tied to REFLO)

$$V_{OUT} = (V_{REFHI} - V_{REFLO})(CODE/16384) + V_{REFLO}$$

- b) GAIN of 1/2: ($X_1/X_{1/2}$ tied to V_{OUT})

$$V_{OUT} = (1/2)(V_{REFHI} - V_{REFLO})(CODE/16384) + V_{REFLO}$$

The LTC 1654 has two SPEED modes: A FAST mode and a SLOW mode. When operating in the FAST mode, the output amplifiers will settle in 3 μ s (typ) to 14 bits on a 4V output swing. In the SLOW mode, they will settle in 8.5 μ s.

The total supply current is 930 μ A in the FAST mode and 540 μ A in the SLOW mode. The output noise voltage density at 10kHz is 170nV/ $\sqrt{\text{Hz}}$ in SLOW mode and 150nV/ $\sqrt{\text{Hz}}$ in FAST mode.

Power Down

Each DAC can also be independently powered down to less than 5 μ A/DAC of supply current. The reference pin also goes into a high impedance state when the DAC is powered down and the reference current will drop to below 0.1 μ A. The amplifiers' output stage is also three-stated but the V_{OUT} pins still have the internal gain-setting resistors connected to them resulting in an effective resistance from V_{OUT} to REFLO. This resistance is typically 90k when the $X_1/X_{1/2}$ pin is tied to V_{OUT} and 36k when $X_1/X_{1/2}$ is tied to REFLO. Because of this resistance, V_{OUT} will go to V_{REFLO} when the DAC is powered down and V_{OUT} is unloaded.

OPERATION

Table 1.

CONTROL				
C3	C2	C1	C0	
0	0	0	0	Load Input Register n
0	0	0	1	Update (Power-Up) DAC Register n
0	0	1	0	Load Input Register n, Update (Power-Up) All
0	0	1	1	Load and Update n
0	1	0	0	Power Down n
0	1	0	1	Fast n (Speed States are Maintained Even If DAC is Put in Power-Down Mode)
0	1	1	0	Slow n (Default State is Slow When Supplies are Powered Up)
0	1	1	1	Reserved (Do Not Use)
1	0	0	0	Reserved (Do Not Use)
1	0	0	1	Reserved (Do Not Use)
1	0	1	0	Reserved (Do Not Use)
1	0	1	1	Reserved (Do Not Use)
1	1	0	0	Reserved (Do Not Use)
1	1	0	1	Reserved (Do Not Use)
1	1	1	0	Reserved (Do Not Use)
1	1	1	1	No Operation

ADDRESS (n)				
A3	A2	A1	A0	
0	0	0	0	DAC A
0	0	0	1	DAC B
0	0	1	0	Reserved (Do Not Use)
0	0	1	1	Reserved (Do Not Use)
0	1	0	0	Reserved (Do Not Use)
0	1	0	1	Reserved (Do Not Use)
0	1	1	0	Reserved (Do Not Use)
0	1	1	1	Reserved (Do Not Use)
1	0	0	0	Reserved (Do Not Use)
1	0	0	1	Reserved (Do Not Use)
1	0	1	0	Reserved (Do Not Use)
1	0	1	1	Reserved (Do Not Use)
1	1	0	0	Reserved (Do Not Use)
1	1	0	1	Reserved (Do Not Use)
1	1	1	0	Reserved (Do Not Use)
1	1	1	1	Both DACs

INPUT WORD

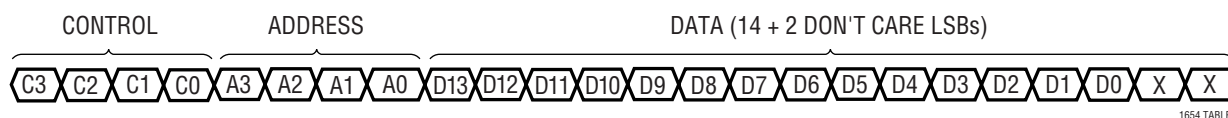

APPLICATIONS INFORMATION

Rail-to-Rail Output Considerations

Rail-to-rail DACs take full advantage of the supply range available to them, but cannot produce output voltages above V_{CC} or below ground. See Figure 2a.

If REFLO is tied to GND, the output for the lowest codes may limit at 0V, as shown in Figure 2b. Similarly, limiting can occur near full scale if the REFHI pin is tied to V_{CC} , as shown in Figure 2c.

The offset, gain error and linearity of the LTC1654 are defined and tested in output ranges that avoid limiting. The low code k_L used in these measurements is defined as the code which gives a nominal output of 32mV above ground; see Table 2.

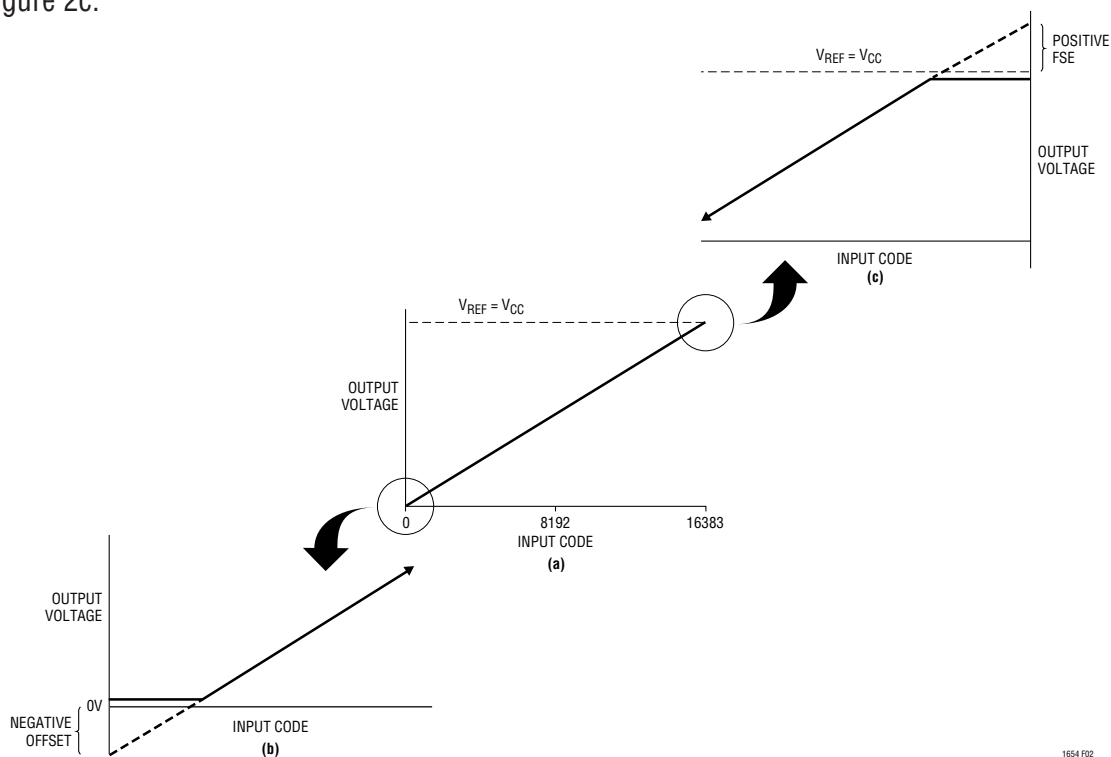

Figure 2. Effects of Rail-to-Rail Operation On a DAC Transfer Curve: (a) Overall Transfer Function, (b) Effect of Negative Offset for Codes Near Zero Scale, (c) Effect of Positive Full-Scale Error for Input Codes Near Full Scale When $V_{REF} = V_{CC}$

Table 2. Low Code k_L

GAIN	V_{REFHI}, V	
	4.096	2.048
1	128	256
1/2	256	512

Note: $V_{REFLO} = 0$

DEFINITIONS

Resolution (n): Resolution is defined as the number of digital input bits (n). It is also the number of DAC output states (2^n) that divide the full-scale range. Resolution does not imply linearity.

Full-Scale Voltage (V_{FS}): This is the output of the DAC when all bits are set to 1.

Voltage Offset Error (V_{OS}): Normally, DAC offset is the voltage at the output when the DAC is loaded with all zeros. The DAC can have a true negative offset, but because the part is operated from a single supply, the output cannot go below 0V. If the offset is negative, the output will remain near 0V resulting in the transfer curve shown in Figure 3.

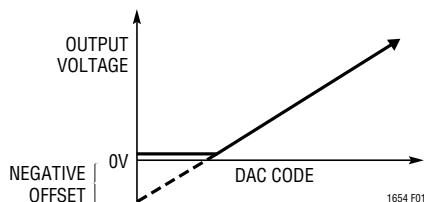

Figure 3. Effect of Negative Offset

Therefore, the offset of the part is measured at low code k_L :

$$V_{OS} = \frac{V_{OUT}(k_L) - \frac{(k_L)(V_{FS})}{2^n - 1}}{\left(1 - \frac{k_L}{2^n - 1}\right)}$$

Least Significant Bit (LSB): One LSB is the ideal voltage difference between two successive codes.

$$LSB = (V_{FS} - V_{OS}) / (2^n - 1) = (V_{FS} - V_{OS}) / 16383$$

Nominal LSBs:

$$LTC1654 \text{ LSB} = 4.09575V / 16383 = 250\mu V$$

Zero-Scale Error (ZSE): The output voltage when the DAC is loaded with all zeros. Since this is a single supply part, this value cannot be less than 0V.

Integral Nonlinearity (INL): End-point INL is the maximum deviation from a straight line passing through the end points of the DAC transfer curve. Because the part operates from a single supply and the output cannot go below zero, the linearity is measured between low code k_L and full scale. The INL error at a given input code is calculated as follows:

$$INL = [V_{OUT} - V_{OS} - (V_{FS} - V_{OS})(\text{code}/16383)] / LSB$$

V_{OUT} = The output voltage of the DAC measured at the given input code

Differential Nonlinearity (DNL): DNL is the difference between the measured change and the ideal one LSB change between any two adjacent codes. The DNL error between any two codes is calculated as follows:

$$DNL = (\Delta V_{OUT} - LSB) / LSB$$

ΔV_{OUT} = The measured voltage difference between two adjacent codes

Digital Feedthrough: The glitch that appears at the analog output caused by AC coupling from the digital inputs when they change state. The area of the glitch is specified in $nV \cdot s$.

TYPICAL APPLICATIONS

This circuit shows how to use an LTC1654 and an LT[®]1077 to make a wide bipolar output swing 14-bit DAC with an offset that can be digitally programmed. V_{OUTA} , which can be set by loading the appropriate code for DAC A, sets the

offset. As this value changes, the transfer curve for the output moves up and down as illustrated in the graph below.

A Wide Swing, Bipolar Output 14-Bit DAC with Digitally Controlled Offset

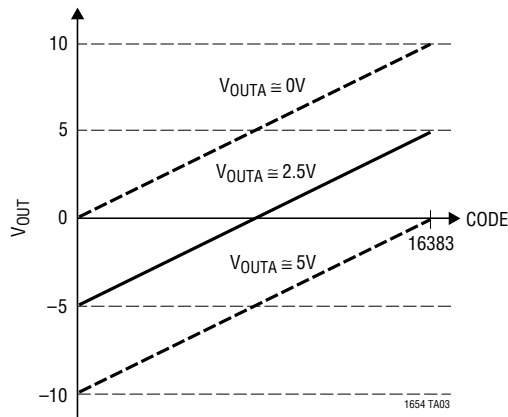
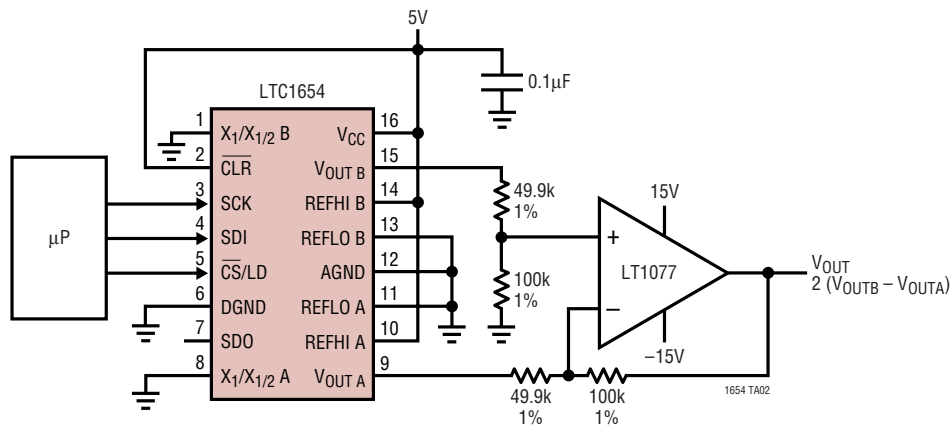

TYPICAL APPLICATIONS

Dual 14-Bit Voltage Output DAC

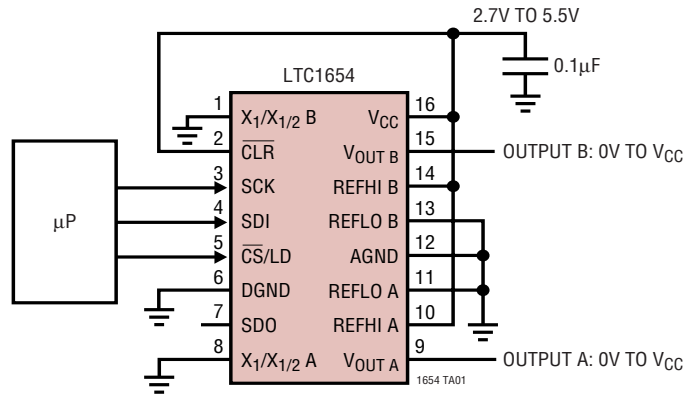

PACKAGE DESCRIPTION

GN Package 16-Lead Plastic SSOP (Narrow .150 Inch) (Reference LTC DWG # 05-08-1641)

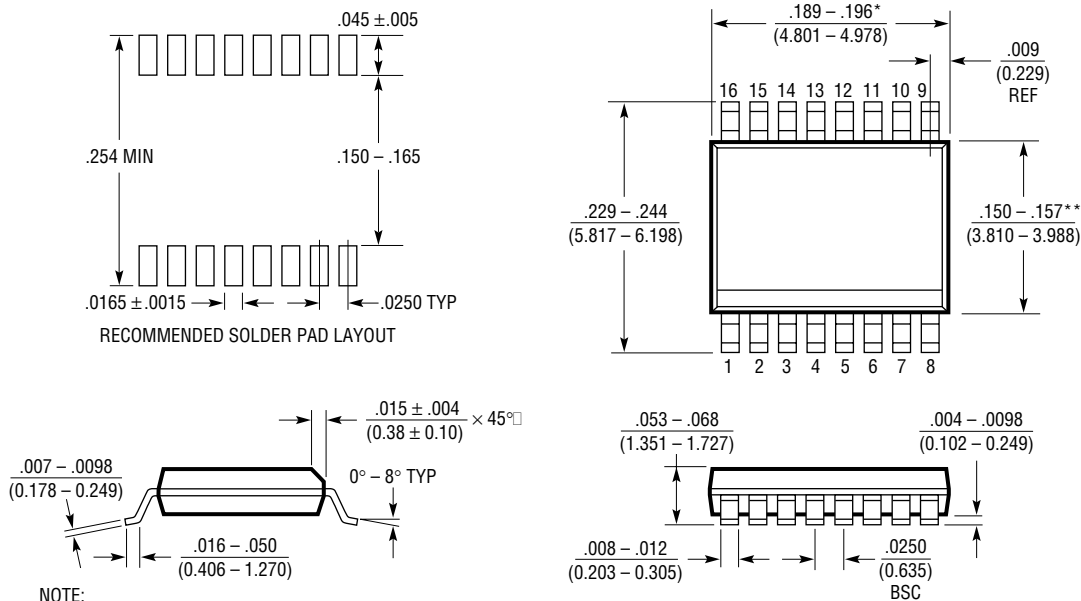

NOTE:

1. CONTROLLING DIMENSION: INCHES
2. DIMENSIONS ARE IN $\frac{\text{INCHES}}{\text{(MILLIMETERS)}}$
3. DRAWING NOT TO SCALE

*DIMENSION DOES NOT INCLUDE MOLD FLASH. MOLD FLASH SHALL NOT EXCEED 0.006" (0.152mm) PER SIDE

**DIMENSION DOES NOT INCLUDE INTERLEAD FLASH. INTERLEAD FLASH SHALL NOT EXCEED 0.010" (0.254mm) PER SIDE

GN16 (SSOP) 0502

TYPICAL APPLICATION

A Wide Swing, Bipolar Output 14-Bit DAC with Digitally Controlled Offset

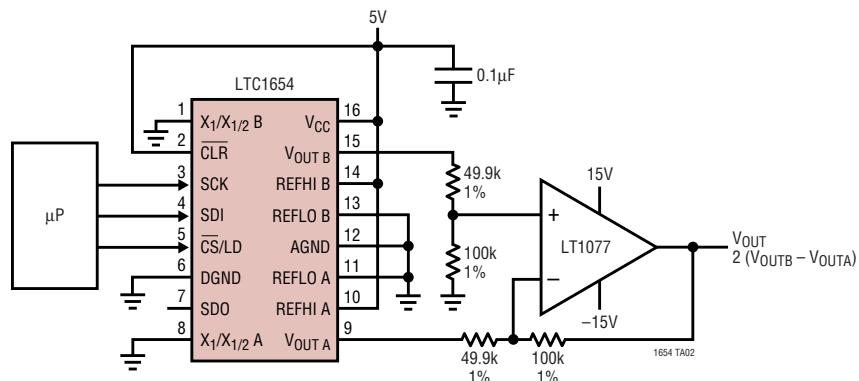

RELATED PARTS

PART NUMBER	DESCRIPTION	COMMENTS
LTC1257	Single 12-Bit V_{OUT} DAC, Full Scale: 2.048V, V_{CC} : 4.75V to 15.75V, Reference Can Be Overdriven Up to 12V, i.e., $FS_{MAX} = 12V$	5V to 15V Single Supply, Complete V_{OUT} DAC in SO-8 Package
LTC1446/LTC1446L	Dual 12-Bit V_{OUT} DACs in SO-8 Package	LTC1446: $V_{CC} = 4.5V$ to 5.5V, $V_{OUT} = 0V$ to 4.095V LTC1446L: $V_{CC} = 2.7V$ to 5.5V, $V_{OUT} = 0V$ to 2.5V
LTC1448	Dual 12-Bit V_{OUT} DAC, V_{CC} : 2.7V to 5.5V	Output Swings from GND to REF. REF Input Can Be Tied to V_{CC}
LTC1450/LTC1450L	Single 12-Bit V_{OUT} DACs with Parallel Interface	LTC1450: $V_{CC} = 4.5V$ to 5.5V, $V_{OUT} = 0V$ to 4.095V LTC1450L: $V_{CC} = 2.7V$ to 5.5V, $V_{OUT} = 0V$ to 2.5V
LTC1451	Single Rail-to-Rail 12-Bit DAC, Full Scale: 4.095V, V_{CC} : 4.5V to 5.5V, Internal 2.048V Reference Brought Out to Pin	5V, Low Power Complete V_{OUT} DAC in SO-8 Package
LTC1452	Single Rail-to-Rail 12-Bit V_{OUT} Multiplying DAC, V_{CC} : 2.7V to 5.5V	Low Power, Multiplying V_{OUT} DAC with Rail-to-Rail Buffer Amplifier in SO-8 Package
LTC1453	Single Rail-to-Rail 12-Bit V_{OUT} DAC, Full Scale: 2.5V, V_{CC} : 2.7V to 5.5V	3V, Low Power, Complete V_{OUT} DAC in SO-8 Package
LTC1454/LTC1454L	Dual 12-Bit V_{OUT} DACs in SO-16 Package with Added Functionality	LTC1454: $V_{CC} = 4.5V$ to 5.5V, $V_{OUT} = 0V$ to 4.095V LTC1454L: $V_{CC} = 2.7V$ to 5.5V, $V_{OUT} = 0V$ to 2.5V
LTC1456	Single Rail-to-Rail Output 12-Bit DAC with Clear Pin, Full Scale: 4.095V, V_{CC} : 4.5V to 5.5V	Low Power, Complete V_{OUT} DAC in SO-8 Package with Clear Pin
LTC1458/LTC1458L	Quad 12 Bit Rail-to-Rail Output DACs with Added Functionality	LTC1458: $V_{CC} = 4.5V$ to 5.5V, $V_{OUT} = 0V$ to 4.095V LTC1458L: $V_{CC} = 2.7V$ to 5.5V, $V_{OUT} = 0V$ to 2.5V
LTC1658	14-Bit Rail-to-Rail Micropower DAC in MSOP, V_{CC} : 2.7V to 5.5V	Output Swings from GND to REF. REF Input Can Be Tied to V_{CC}
LTC1659	Single Rail-to-Rail 12-Bit V_{OUT} DAC in 8-Pin MSOP, V_{CC} : 2.7V to 5.5V	Low Power, Multiplying V_{OUT} DAC in MS8 Package. Output Swings from GND to REF. REF Input Can Be Tied to V_{CC}

References

LT1460	Micropower Precision Reference	Low Cost, 10ppm Drift
LT1461	Precision Voltage Reference	Ultralow Drift 3ppm/°C, Initial Accuracy: 0.04%
LT1634	Micropower Precision Reference	Low Drift 10ppm/°C, Initial Accuracy: 0.05%

Looking for pricing, stock, or lifecycle information?

Click below to explore more details on WIN SOURCE:

 [View LTC1654CGN#PBF on WIN SOURCE](#)

 [Linear Technology](#) Information

Optimize Your Supply Chain with WIN SOURCE Solutions

-  Global Sourcing Solution
-  Obsolete Management
-  Cost Control Management
-  Shortage Management
-  Alternative Solution
-  Excess Inventory Management