



**THE DATASHEET OF
LTC1164CSW#TRPBF**



FEATURES

- Low Power
- 4 Filters in a 0.3" Wide Package
- 1/2 the Noise of the LTC1059, 60, 61 Devices
- Wide Output Swing
- Clock-to-Center Frequency Ratios of 50:1 and 100:1
- Operates from $\pm 2.37V$ to $\pm 8V$ Power Supplies
- Customized Version with Internal Resistors Available
- Ratio of 50:1 and 100:1 Simultaneously Available

APPLICATIONS

- Antialiasing Filters
- Telecom Filters
- Spectral Analysis
- Loop Filters
- For Fixed Lowpass Filter Requirements use the LTC1164-XX Series

 LTC and LT are registered trademarks of Linear Technology Corporation.
 LTCMOS trademark of Linear Technology Corporation.

DESCRIPTION

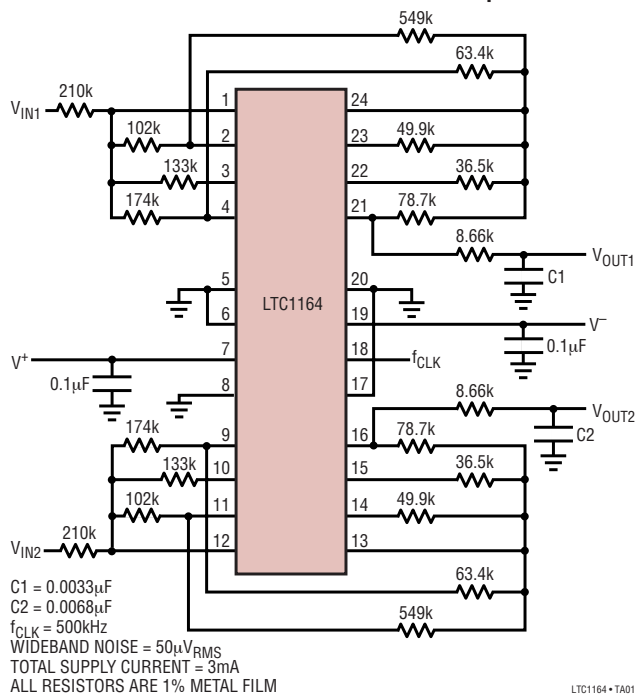
The LTC[®]1164 consists of four low power, low noise 2nd order switched capacitor filter building blocks. Each building block typically consumes 850 μ A supply current. Low power is achieved without sacrificing noise and distortion. Each building block, together with 3 to 5 resistors, can provide 2nd order functions like lowpass, highpass, bandpass, and notch. The center frequency of each 2nd order section can be tuned with an external clock, or a clock and resistor ratio. For $Q < 5$, the center frequency range is from 0.1Hz to 20kHz. Up to 8th order filters can be realized by cascading all four 2nd order sections. Any classical filter realization (such as Butterworth, Cauer, Bessel, and Chebyshev) can be formed.

A customized monolithic version of the LTC1164 including internal thin film resistors can be obtained. Consult LTC Marketing for details.

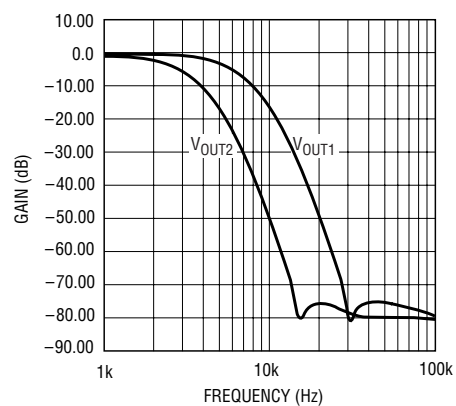
The LTC1164 is manufactured using Linear Technology's enhanced LTCMOS[™] silicon gate process.

TYPICAL APPLICATION

Dual 5th Order Linear Phase Filter with Stopband Notch



Dual 5th Order Linear Phase Filter with Stopband Notch, $f_{CLK} = 500kHz$



SUPPLY VOLTAGE	V_{IN}	TOTAL HARMONIC DISTORTION	SIGNAL/NOISE
± 2.5	1V _{RMS}	0.015% (-76dB)	86dB
± 5.0	2V _{RMS}	0.025% (-72dB)	92dB
± 7.5	4V _{RMS}	0.04% (-68dB)	98dB

LTC1164 • TA01

1164fa

LTC1164

ABSOLUTE MAXIMUM RATINGS (Note 1)

Total Supply Voltage (V^+ to V^-) 16.5V
 Power Dissipation 500mW
 Storage Temperature Range -65°C to 150°C
 Lead Temperature (Soldering, 10 sec) 300°C

Operating Temperature Range

LTC1164AM, LTC1164M (**OBSELETE**) -55°C to 125°C

LTC1164AC, LTC1164C -40°C to 85°C

PACKAGE/ORDER INFORMATION

TOP VIEW	ORDER PART NUMBER	TOP VIEW	ORDER PART NUMBER
<p>N PACKAGE 24-LEAD PDIP $T_{JMAX} = 110^{\circ}\text{C}$, $\theta_{JA} = 65^{\circ}\text{C/W}$</p>	<p>LTC1164ACN LTC1164CN</p>	<p>SW PACKAGE 24-LEAD PLASTIC SO $T_{JMAX} = 110^{\circ}\text{C}$, $\theta_{JA} = 75^{\circ}\text{C/W}$</p>	<p>LTC1164CSW LTC1164ACSW</p>
<p>J PACKAGE 24-LEAD CERDIP $T_{JMAX} = 150^{\circ}\text{C}$, $\theta_{JA} = 100^{\circ}\text{C/W}$</p> <p>OBSELETE PACKAGE Consider the N24 Package as an Alternate Source</p>	<p>LTC1164AMJ LTC1164MJ LTC1164ACJ LTC1164CJ</p>		

LTC221/222 • P0101

Consult LTC Marketing for parts specified with wider operating temperature ranges.

ELECTRICAL CHARACTERISTICS The ● denotes specifications which apply over the full operating temperature range, otherwise specifications are at $T_A = 25^{\circ}\text{C}$. (Internal Op Amps) $V_S = \pm 5\text{V}$, $R_L = 5\text{k}\Omega$ unless otherwise noted.

PARAMETER	CONDITIONS	MIN	TYP	MAX	UNITS
Supply Voltage Range		± 2.37		± 8	V
Voltage Swings	$V_S = \pm 2.5\text{V}$		± 1.6		V
	$V_S = \pm 5.0\text{V}$	● ± 3.8	± 4.2		V
	$V_S = \pm 7.5\text{V}$		± 6.1		V
Output Short Circuit Current (Source/Sink)	$V_S = \pm 5.0\text{V}$		1		mA
DC Open Loop Gain	$V_S = \pm 5.0\text{V}$		80		dB
GBW Product	$V_S = \pm 5.0\text{V}$		2		MHz
Slew Rate	$V_S = \pm 5.0\text{V}$		1.6		V/ μs

1164fa

ELECTRICAL CHARACTERISTICS

The ● denotes specifications which apply over the full operating temperature range, otherwise specifications are at $T_A = 25^\circ\text{C}$. (Complete Filter) $V_S = \pm 5\text{V}$, TTL Clock Input Level, unless otherwise specified.

PARAMETER	CONDITIONS	MIN	TYP	MAX	UNITS
Center Frequency Range			0.1 to 20k		Hz
Input Frequency Range (Note 2)	50:1 100:1			$< f_{\text{CLK}}$ $< f_{\text{CLK}}/2$	Hz Hz
Clock-to-Center Frequency Ratio, f_{CLK}/f_0	Sides A, B, C: Mode 1, $R_1 = R_3 = 50\text{k}$, $R_2 = 5\text{k}$, Side D: Mode 3, $R_1 = R_3 = 50\text{k}$, $R_2 = R_4 = 5\text{k}$ $f_0 = 5\text{kHz}$, $Q = 10$				
LTC1164A	50:1, $f_{\text{CLK}} = 250\text{kHz}$	●		50 ± 0.5	%
LTC1164	50:1, $f_{\text{CLK}} = 250\text{kHz}$	●		50 ± 0.9	%
LTC1164A	100:1, $f_{\text{CLK}} = 500\text{kHz}$	●		100 ± 0.5	%
LTC1164	100:1, $f_{\text{CLK}} = 500\text{kHz}$	●		100 ± 0.9	%
Clock-to-Center Frequency Ratio, Side to Side Matching	Sides A, B, C, Mode 1, $f_0 = 5\text{kHz}$, $Q = 10$ Side D Mode 3, $f_0 = 5\text{kHz}$, $Q = 10$				
LTC1164A	50:1, $f_{\text{CLK}} = 250\text{kHz}$	●		0.5	%
LTC1164	50:1, $f_{\text{CLK}} = 250\text{kHz}$	●		1.0	%
Q Accuracy	Sides A, B, C, Mode 1, $f_0 = 5\text{kHz}$, $Q = 10$				
	50:1, $f_{\text{CLK}} = 250\text{kHz}$	●	± 2	± 5	%
	100:1, $f_{\text{CLK}} = 500\text{kHz}$	●	± 2	± 5	%
	Side D Mode 3, $f_0 = 5\text{kHz}$, $Q = 10$				
	50:1, $f_{\text{CLK}} = 250\text{kHz}$	●	± 3	± 6	%
	100:1, $f_{\text{CLK}} = 500\text{kHz}$	●	± 6	± 12	%
f_0 Temperature Coefficient	$f_{\text{CLK}} \leq 500\text{kHz}$		± 1		ppm/ $^\circ\text{C}$
Q Temperature Coefficient	$f_{\text{CLK}} \leq 250\text{kHz}$		± 5		ppm/ $^\circ\text{C}$
Maximum Clock Frequency	Mode 1, $Q < 2.5$ $V_S \geq \pm 7.0\text{V}$, 50:1 or 100:1		1.5		MHz
	Mode 3, $Q < 5$ $V_S \geq \pm 5\text{V}$, 50:1 or 100:1		1.0		MHz
	Mode 3, $Q < 5$ $V_S = \pm 2.5\text{V}$, 50:1 or 100:1		500		kHz
f_{CLK} Feedthrough	$f_{\text{CLK}} \leq 500\text{kHz}$, $V_S = \pm 5\text{V}$		200		μV_{RMS}
DC Offset Voltages (See Figure 1 and Table 1)	V_{OS1}	●	2	20	mV
	V_{OS2}	●	3	45	mV
	V_{OS3}	●	3	45	mV
Power Supply Current	$V_S = \pm 2.5\text{V}$		4		mA
	$V_S = \pm 5\text{V}$, Temp $\geq 25^\circ\text{C}$		3.6	5	mA
	$V_S = \pm 5\text{V}$	●	5.6	8	mA
	$V_S = \pm 7.5\text{V}$, Temp $\geq 25^\circ\text{C}$		6	8	mA
	$V_S = \pm 7.5\text{V}$	●	9	11	mA

Note 1: Absolute Maximum Ratings are those values beyond which the life of a device may be impaired.

Note 2: Guaranteed by design. Not tested.

ELECTRICAL CHARACTERISTICS

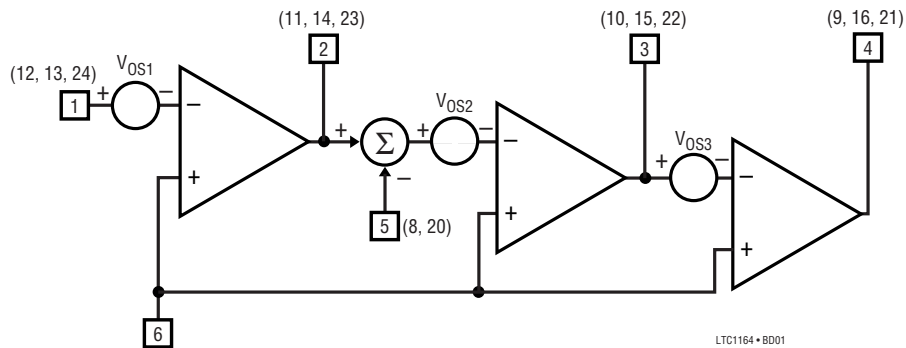
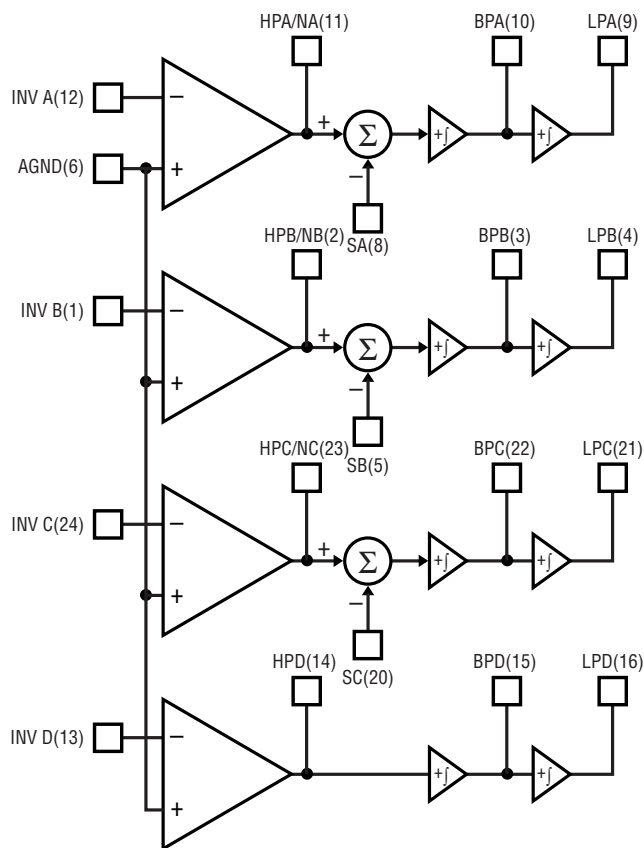


Figure 1. Equivalent Input Offsets of 1/4 LTC1164 Filter Building Block

Table 1. Output DC Offsets One 2nd Order Section

MODE	V_{OSN} PIN 2, 11, 14, 23	V_{OSBP} PINS 3, 10, 15, 22	V_{OSLP} PINS 4, 9, 16, 21
1	$V_{OS1}[(1/Q) + 1 + H_{OLP}] - V_{OS3}/Q$	V_{OS3}	$V_{OSN} - V_{OS2}$
1b	$V_{OS1}[(1/Q) + 1 + R2/R1] - V_{OS3}/Q$	V_{OS3}	$\sim (V_{OSN} - V_{OS2})(1 + R5/R6)$
2	$[V_{OS1}(1 + R2/R1 + R2/R3 + R2/R4) - V_{OS3}(R2/R3)] \cdot [R4/(R2 + R4)] + V_{OS2}[R2/(R2 + R4)]$	V_{OS3}	$V_{OSN} - V_{OS2}$
3	V_{OS2}	V_{OS3}	$V_{OS1} \left[1 + \frac{R4}{R1} + \frac{R4}{R2} + \frac{R4}{R3} \right] - V_{OS2} \left(\frac{R4}{R2} \right) - V_{OS3} \left(\frac{R4}{R3} \right)$

BLOCK DIAGRAM



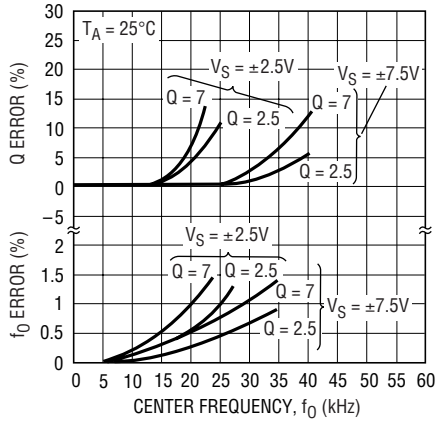
- V+(7)
- 50/100(17)
- CLK(18)
- V-(19)

BY TYING PIN 17 TO V+ ALL SECTIONS
OPERATE WITH (f_{CLK}/f_O) = (50:1)
BY TYING PIN 17 TO V- ALL SECTIONS
OPERATE WITH (f_{CLK}/f_O) = (100:1)
BY TYING PIN 17 TO AGND SECTIONS A & D
OPERATE WITH (f_{CLK}/f_O) = (100:1) AND
SECTIONS B & C OPERATE AT (50:1)

LTC1164 • B002

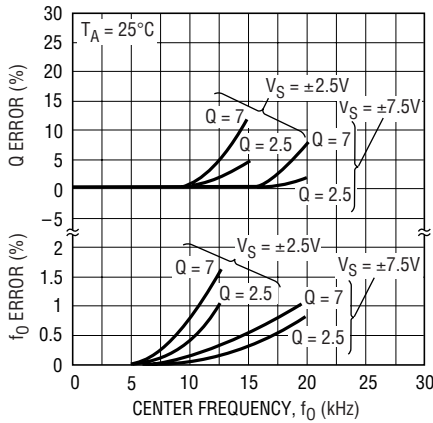
TYPICAL PERFORMANCE CHARACTERISTICS

Mode 1, (f_{CLK}/f_0) = 50:1



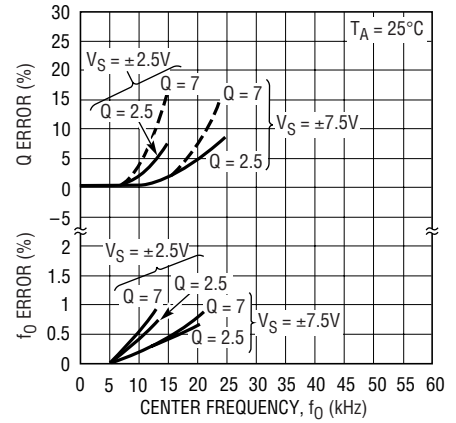
LTC1164 • TPC01

Mode 1, (f_{CLK}/f_0) = 100:1



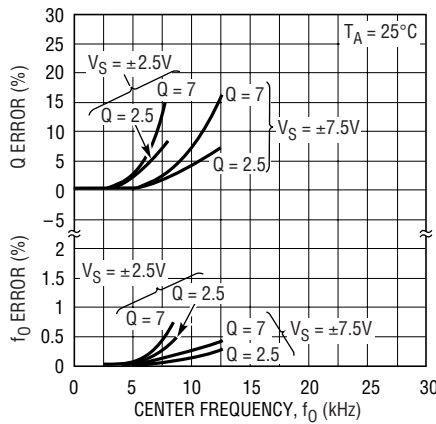
LTC1164 • TPC02

Mode 3, (f_{CLK}/f_0) = 50:1



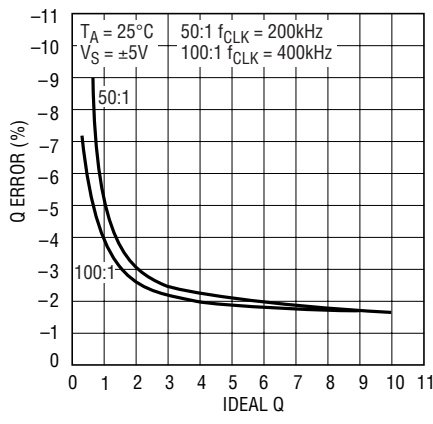
LTC1164 • TPC03

Mode 3, (f_{CLK}/f_0) = 100:1



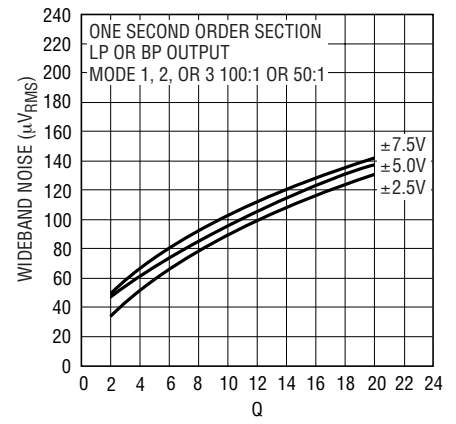
LTC1164 • TPC04

Mode 3 Q Error vs Ideal Q



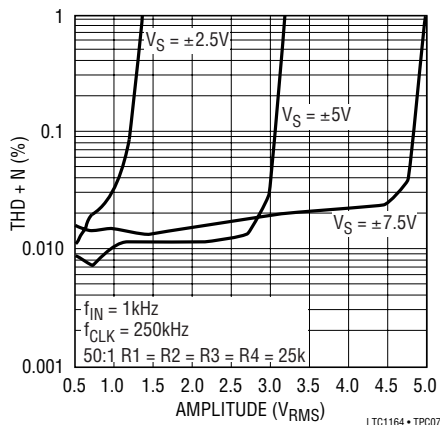
LTC1164 • TPC05

Wideband Noise vs Q



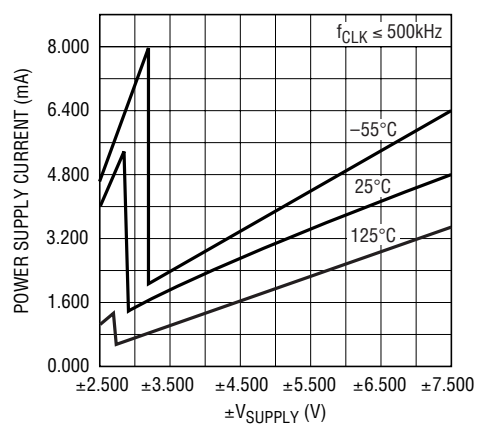
LTC1164 • TPC06

Total Harmonic Distortion vs Output Amplitude



LTC1164 • TPC07

Power Supply Current vs Voltage



LTC1164 • TPC08

PIN FUNCTIONS

Power Supplies (Pins 7,19)

They should be bypassed with $0.1\mu\text{F}$ ceramic disc. Low noise, non-switching, power supplies are recommended. The device operates with a single 5V supply and with dual supplies. The absolute maximum operating power supply voltage is $\pm 8.25\text{V}$. Supply reversal is not allowed and can cause latch up. When using dual supplies, loads between the positive and negative supply (even light loads) can cause momentary supply reversal during power-up. A clamp diode from each supply to ground will prevent reversal and latch problems.

Clock (Pin 18)

For $\pm 5\text{V}$ supplies the logic threshold level is 1.8V . For $\pm 8\text{V}$ and 0 to 5V supplies the logic threshold level is 2.8V . The logic threshold levels vary $\pm 100\text{mV}$ over the full military temperature range. The recommended duty cycle of the input clock is 50%, although for clock frequencies below 500kHz the clock “on” time can be as low as 200ns . The maximum clock frequency for single 5V supply and Q values < 5 is 500kHz and for $\pm 5\text{V}$ supplies and above is 1MHz . The clock input can be applied before power is turned on as long as there is no chance the clock signal will go below the V^- supply.

AGND (PIN 6)

When the LTC1164 operates with dual supplies, Pin 6 should be tied to system ground. When the LTC1164 operates with a single positive supply, the analog ground pin should be tied to $1/2$ supply and it should be bypassed with a $4.7\mu\text{F}$ solid tantalum in parallel with a $0.1\mu\text{F}$ ceramic disc, Figure 2. The positive input of all the internal op amps, as well as the common reference of all the internal switches, are internally tied to the analog ground pin. Because of this, a very “clean” ground is recommended.

50/100 (Pin 17)

By tying Pin 17 to V^+ , all filter sections operate with a clock-to-center frequency ratio internally set at 50:1. When Pin 17 is at mid-supplies, sections B and C operate with $(f_{\text{CLK}}/f_0) = 50:1$ and sections A and D operate at $(100:1)$. When Pin 17 is shorted to the negative supply pin, all filter sections operate with $(f_{\text{CLK}}/f_0) = 100:1$.

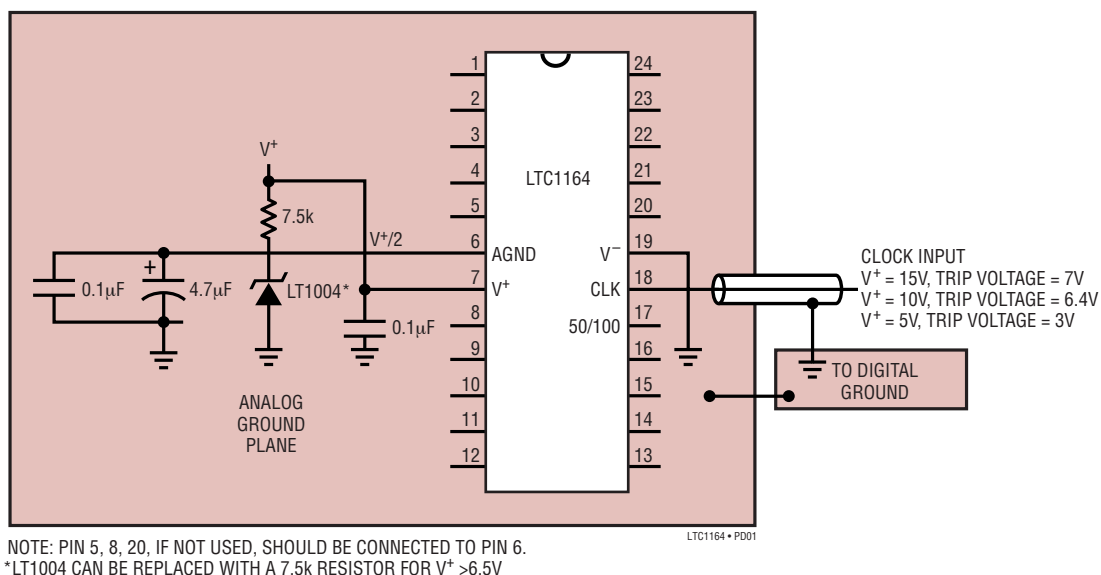


Figure 2. Single Supply Operation

APPLICATIONS INFORMATION

ANALOG CONSIDERATIONS

1. Grounding and Bypassing

The LTC1164 should be used with separated analog and digital ground planes and single point grounding techniques.

Pin 6 (AGND) should be tied directly to the analog ground plane.

Pin 7 (V^+) should be bypassed to the ground plane with a $0.1\mu\text{F}$ ceramic disk with leads as short as possible. Pin 19 (V^-) should be bypassed with a $0.1\mu\text{F}$ ceramic disk. For single supply applications, V^- can be tied to the analog ground plane.

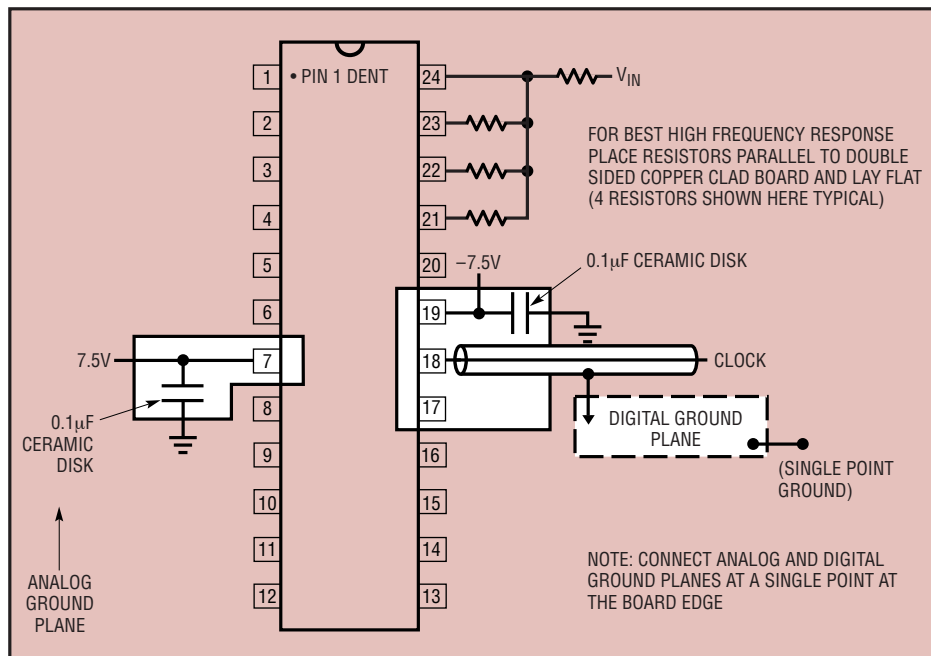
For good noise performance, V^+ and V^- must be free of noise and ripple.

All analog inputs should be referenced directly to the single point ground. The clock inputs should be shielded from and/or routed away from the analog circuitry and a separate digital ground plane used.

Figure 3 shows an example of an ideal ground plane design for a two sided board. Of course this much ground plane will not always be possible, but users should strive to get as close to this as possible. Proto boards are not recommended.

2. Buffering the Filter Output

When driving coaxial cables and 1x scope probes, the filter output should be buffered. This is important especially when high Q s are used to design a specific filter. *Inadequate buffering may cause errors in noise, distortion, Q , and gain measurements.* When 10x probes are used, buffering is usually not required. A buffer is recommended especially when THD tests are performed. As shown in Figure 4, the buffer should be adequately bypassed to minimize clock feedthrough.



LTC1164 • A01

Figure 3. Example Ground Plane Breadboard Technique for LTC1164

APPLICATIONS INFORMATION

3. Offset Nulling

Lowpass filters may have too much DC offset for some users. A servo circuit may be used to actively null the offsets of the LTC1164 or any LTC switched capacitor filter. The circuit shown in Figure 5 will null offsets to better than 300µV. This circuit takes seconds to settle because of the integrator pole frequency.

4. Noise

All the noise performance mentioned excludes the clock feedthrough. Noise measurements will degrade if the already described grounding, bypassing, and buffering techniques are not practiced. The Wideband Noise vs Q curve shown in the Typical Performance Characteristics Section is a very good representation of the noise performance of this device.

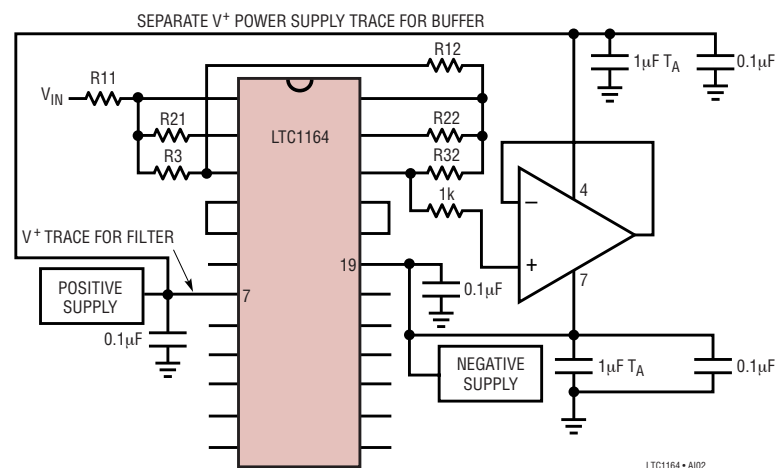


Figure 4. Buffering the Output of a 4th Order Bandpass Realization

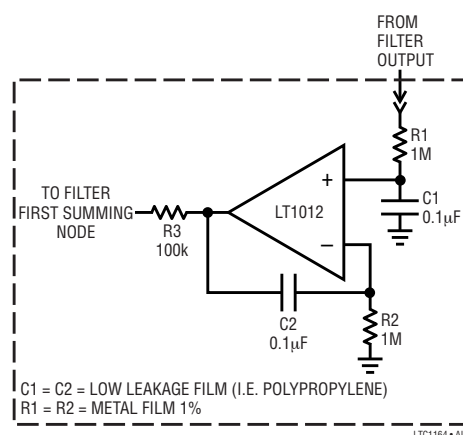


Figure 5. Servo Amplifier

MODES OF OPERATION

PRIMARY MODES

Mode 1

In Mode 1, the ratio of the external clock frequency to the center frequency of each 2nd order section is internally fixed at 50:1 or 100:1. Figure 6 illustrates Mode 1 providing 2nd order notch, lowpass, and bandpass outputs. Mode 1 can be used to make high order Butterworth lowpass filters; it can also be used to make low Q notches and for cascading 2nd order bandpass functions tuned at the same center frequency with unity gain. Mode 1 is faster than Mode 3. Note that Mode 1 can only be implemented with 3 of the 4 LTC1164 sections because section D has no externally available summing node. Section D, however, can be internally connected in Mode 1 upon special request.

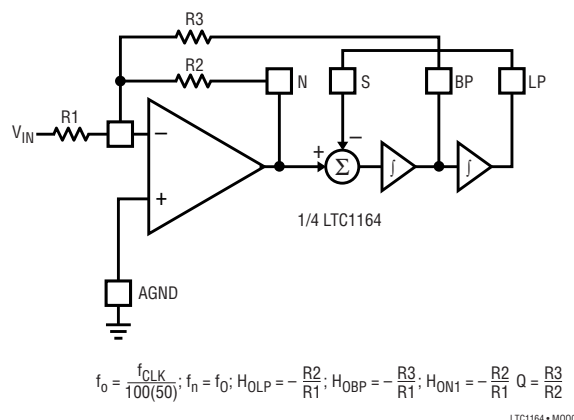


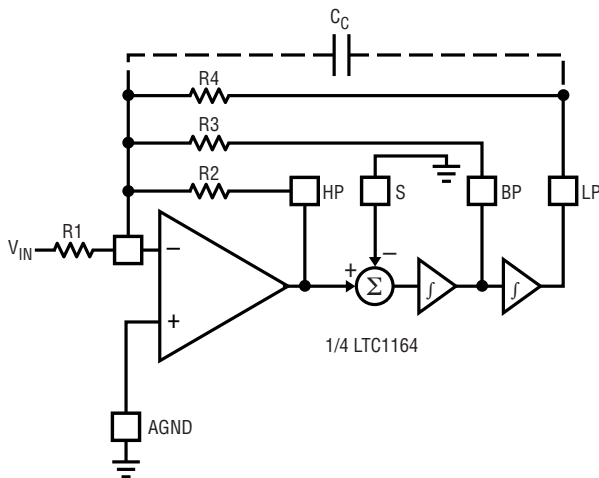
Figure 6. Mode 1: 2nd Order Filter Providing Notch, Bandpass, Lowpass

MODES OF OPERATION

Mode 3

Mode 3 is the second of the primary modes. In Mode 3, the ratio of the external clock frequency to the center frequency of each 2nd order section can be adjusted above or below 50:1 or 100:1. Side D of the LTC1164 can only be connected in Mode 3. Figure 7 illustrates Mode 3, the classical state variable configuration, providing highpass, bandpass, and lowpass 2nd order filter functions. Mode 3 is slower than Mode 1. Mode 3 can be used to make high order all-pole bandpass, lowpass, highpass and notch filters.

When the internal clock-to-center frequency ratio is set at 50:1, the design equations for Q and bandpass gain are different from the 100:1 case. This was done to provide speed without penalizing the noise performance.



$$\text{MODE 3 (100:1): } f_0 = \frac{f_{\text{CLK}}}{100} \sqrt{\frac{R_2}{R_4}}; Q = \frac{R_3}{R_2} \sqrt{\frac{R_2}{R_4}}; H_{\text{HP}} = -R_2/R_1;$$

$$H_{\text{OBP}} = -R_3/R_1; H_{\text{OLP}} = -R_4/R_1$$

$$\text{MODE 3 (50:1): } f_0 = \frac{f_{\text{CLK}}}{50} \sqrt{\frac{R_2}{R_4}}; Q = \frac{1.005 \sqrt{R_2/R_4}}{(R_2/R_3) - (R_2/16R_4)};$$

$$H_{\text{OLP}} = -R_2/R_1; H_{\text{OBP}} = -\frac{R_3/R_1}{1 - (R_3/16R_4)}; H_{\text{OLP}} = -R_4/R_1$$

NOTE: THE 50:1 EQUATIONS FOR MODE 3 ARE DIFFERENT FROM THE EQUATIONS FOR MODE 3 OPERATION OF THE LTC1059, LTC1060 AND LTC1061. START WITH f_0 , CALCULATE R_2/R_4 , SET R_4 ; FROM THE Q VALUE, CALCULATE R_3 :

$$R_3 = \frac{R_2}{\frac{1.005}{Q} \sqrt{\frac{R_2}{R_4}} + \frac{R_2}{16R_4}}; \text{ THEN CALCULATE } R_1 \text{ TO SET THE DESIRED GAIN}$$

LTC1164 • M0002

Figure 7. Mode 3: 2nd Order Filter Providing Highpass, Bandpass, Lowpass

SECONDARY MODES

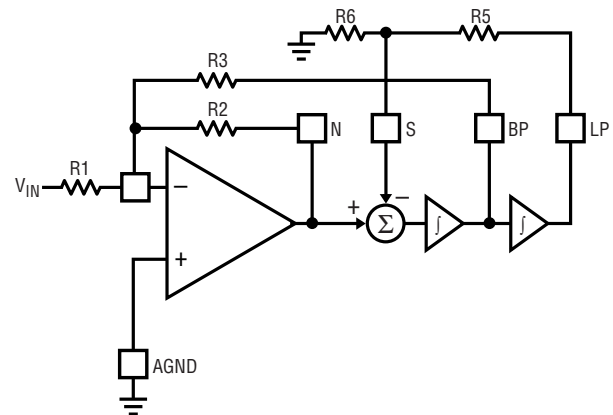
Mode 1b

Mode 1b is derived from Mode 1. In Mode 1b, Figure 8, two additional resistors R5 and R6, are added to alternate the amount of voltage feedback from the lowpass output into the input of the SA (or SB or SC) switched capacitor summer. This allows the filter clock-to-center frequency ratio to be adjusted beyond 50:1 or 100:1. Mode 1b maintains the speed advantages of Mode 1.

Mode 2

Mode 2 is a combination of Mode 1 and Mode 3, as shown in Figure 9. With Mode 2, the clock-to-center frequency ratio, f_{CLK}/f_0 , is always less than 50:1 or 100:1. The advantage of Mode 2 is that it provides less sensitivity to resistor tolerances than does Mode 3. As in Mode 1, Mode 2 has a notch output which depends on the clock frequency, and the notch frequency is therefore less than the center frequency, f_0 .

When the internal clock-to-center frequency ratio is set at 50:1, the design equations for Q and bandpass gain are different from the 100:1 case.



$$f_0 = \frac{f_{\text{CLK}}}{100(50)} \sqrt{\frac{R_6}{R_5 + R_6}}; f_n = f_0; Q = \frac{R_3}{R_2} \sqrt{\frac{R_6}{R_5 + R_6}};$$

$$H_{\text{ON1}} (f \rightarrow 0) = H_{\text{ON2}} \left(f \rightarrow \frac{f_{\text{CLK}}}{2} \right) = -\frac{R_2}{R_1}; H_{\text{OLP}} = \frac{-R_2/R_1}{R_6/(R_5 + R_6)};$$

$$H_{\text{OBP}} = -\frac{R_3}{R_1}; (R_5/R_6) < 5k\Omega$$

LTC1164 • M0003

Figure 8. Mode 1b: 2nd Order Filter Providing Notch, Bandpass, Lowpass

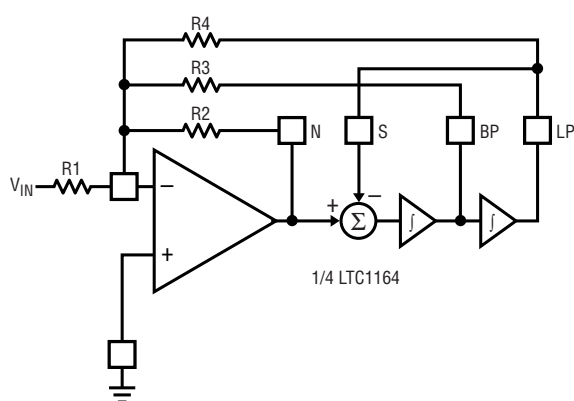
MODES OF OPERATION

Mode 3A

This is an extension of Mode 3 where the highpass and lowpass output are summed through two external resistors R_H and R_L to create a notch. This is shown in Figure 10. Mode 3A is more versatile than Mode 2 because the notch frequency can be higher or lower than the center frequency of the 2nd order section. The external op amp of Figure 10 is not always required. When cascading the sections of the LTC1164, the highpass and lowpass

outputs can be summed directly into the inverting input of the next section. The topology of Mode 3A is useful for elliptic highpass and notch filters with clock to cutoff frequency ratios higher than 100:1. This is often required to extend the allowed input signal frequency range and to avoid premature aliasing.

When the internal clock-to-center frequency ratio is set at 50:1, the design equations for Q and bandpass gain are different from the 100:1 case.



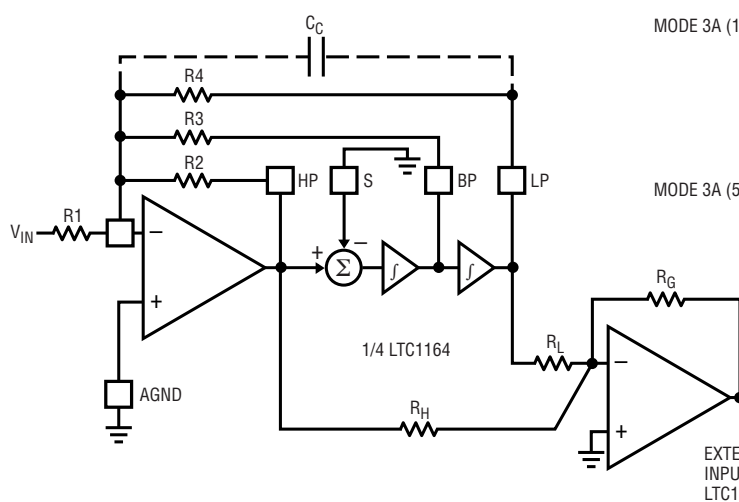
$$\begin{aligned} \text{MODE 2 (100:1): } & f_o = \frac{f_{\text{CLK}}}{100} \sqrt{1 + \frac{R_2}{R_4}}; f_n = \frac{f_{\text{CLK}}}{50}; Q = \frac{R_3}{R_2} \sqrt{1 + \frac{R_2}{R_4}}; H_{\text{OLP}} = \frac{-R_2/R_1}{1 + (R_2/R_4)} \\ & H_{\text{OBP}} = -R_3/R_1; H_{\text{ON1}}(f \rightarrow 0) = \frac{-R_2/R_1}{1 + (R_2/R_4)}; H_{\text{ON2}}\left(f \rightarrow \frac{f_{\text{CLK}}}{2}\right) = -R_2/R_1 \\ \text{MODE 2 (50:1): } & f_o = \frac{f_{\text{CLK}}}{50} \sqrt{1 + \frac{R_2}{R_4}}; f_n = \frac{f_{\text{CLK}}}{50}; Q = \frac{1.005(\sqrt{1 + R_2/R_4})}{(R_2/R_3) - (R_2/16R_4)}; H_{\text{OLP}} = \frac{-R_2/R_1}{1 + (R_2/R_4)} \\ & H_{\text{OBP}} = -\frac{R_3/R_1}{1 - (R_3/16R_4)}; H_{\text{ON1}}(f \rightarrow 0) = \frac{-R_2/R_1}{1 + (R_2/R_4)} \\ & H_{\text{ON2}}\left(f \rightarrow \frac{f_{\text{CLK}}}{2}\right) = -R_2/R_1 \end{aligned}$$

NOTE: THE 50:1 EQUATIONS FOR MODE 2 ARE DIFFERENT FROM THE EQUATIONS FOR MODE 2 OPERATION OF THE LTC1059, LTC1060 AND LTC1061. START WITH f_o , CALCULATE R_2/R_4 , SET R_4 ; FROM THE Q VALUE, CALCULATE R_3 :

$$R_3 = \frac{R_2}{Q \sqrt{1 + \frac{R_2}{R_4} + 16R_4}}; \text{ THEN CALCULATE } R_1 \text{ TO SET THE DESIRED GAIN}$$

LTC1164 • M0004

Figure 9. Mode 2: 2nd Order Filter Providing Notch, Bandpass, Lowpass



$$\begin{aligned} \text{MODE 3A (100:1): } & f_o = \frac{f_{\text{CLK}}}{100} \sqrt{\frac{R_2}{R_4}}; f_n = \frac{f_{\text{CLK}}}{100} \sqrt{\frac{R_H}{R_L}}; H_{\text{OHP}} = -R_2/R_1; H_{\text{OBP}} = -R_3/R_1 \\ & H_{\text{OLP}} = -R_4/R_1; H_{\text{ON1}}(f \rightarrow 0) = \frac{R_G}{R_L} \times \frac{R_4}{R_1}; H_{\text{ON2}}\left(f \rightarrow \frac{f_{\text{CLK}}}{2}\right) = \frac{R_G}{R_H} \times \frac{R_2}{R_1} \\ & H_{\text{ON}}(f = f_o) = Q \left(\frac{R_G}{R_L} H_{\text{OLP}} - \frac{R_G}{R_H} H_{\text{OHP}} \right); Q = \frac{R_3}{R_2} \sqrt{\frac{R_2}{R_4}} \\ \text{MODE 3A (50:1): } & f_o = \frac{f_{\text{CLK}}}{50} \sqrt{\frac{R_2}{R_4}}; f_n = \frac{f_{\text{CLK}}}{50} \sqrt{\frac{R_H}{R_L}}; H_{\text{OHP}}\left(f \rightarrow \frac{f_{\text{CLK}}}{2}\right) = -R_2/R_1 \\ & H_{\text{OBP}} = -\frac{R_3/R_1}{1 - (R_3/16R_4)}; H_{\text{OLP}}(f = 0) = -R_4/R_1; Q = \frac{1.005(\sqrt{R_2/R_4})}{(R_2/R_3) - (R_2/16R_4)} \end{aligned}$$

NOTE: THE 50:1 EQUATIONS FOR MODE 3A ARE DIFFERENT FROM THE EQUATIONS FOR MODE 3A OPERATION OF THE LTC1059, LTC1060 AND LTC1061. START WITH f_o , CALCULATE R_2/R_4 , SET R_4 ; FROM THE Q VALUE, CALCULATE R_3 :

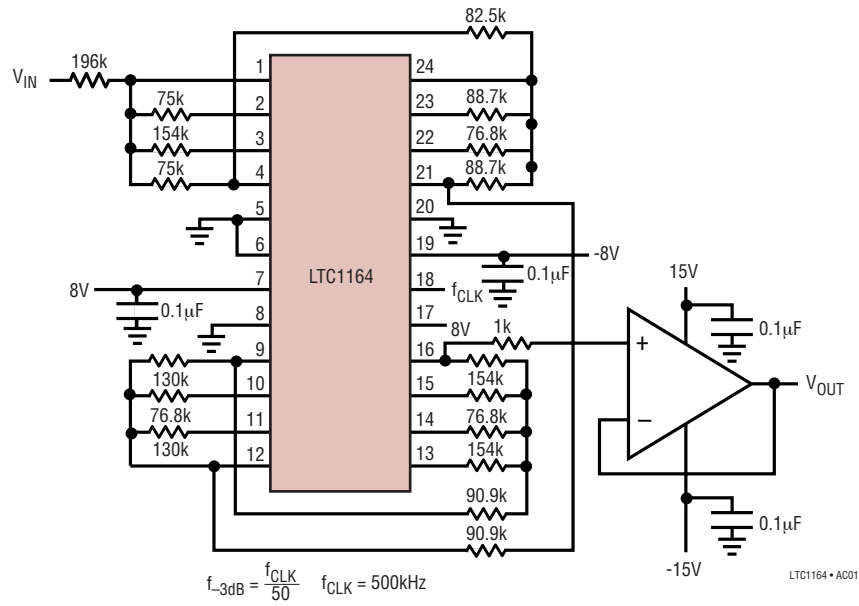
$$R_3 = \frac{R_2}{Q \sqrt{\frac{R_2}{R_4} + 16R_4}}; \text{ THEN CALCULATE } R_1 \text{ TO SET THE DESIRED GAIN}$$

LTC1164 • M0005

EXTERNAL OP AMP OR INPUT OP AMP OF THE LTC1164, SIDE A, B, C, D

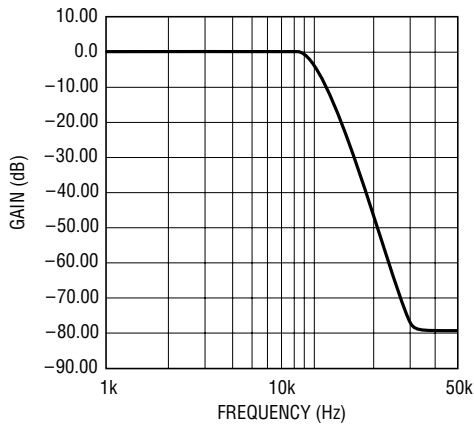
Figure 10. Mode 3A: 2nd Order Filter Providing Highpass, Bandpass, Lowpass, Notch

TYPICAL APPLICATIONS

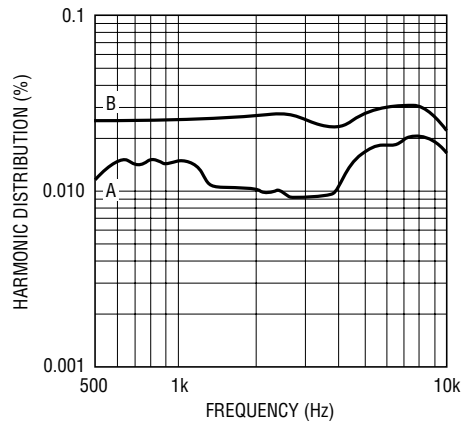


**Figure 11. 8th Order Lowpass Butterworth, Passband Noise $90\mu V_{RMS}$
(Also Refer to the LTC1164-5)**

**LTC1164 8th Order Butterworth,
 $f_{CLK} = 500kHz$, $f_{-3dB} = 10kHz$**



**LTC1164 8th Order Butterworth,
 $f_{CLK} = 500kHz$, $f_{-3dB} = 10kHz \pm 8V$,
A. $2V_{RMS}$, B. $4V_{RMS}$**



TYPICAL APPLICATIONS

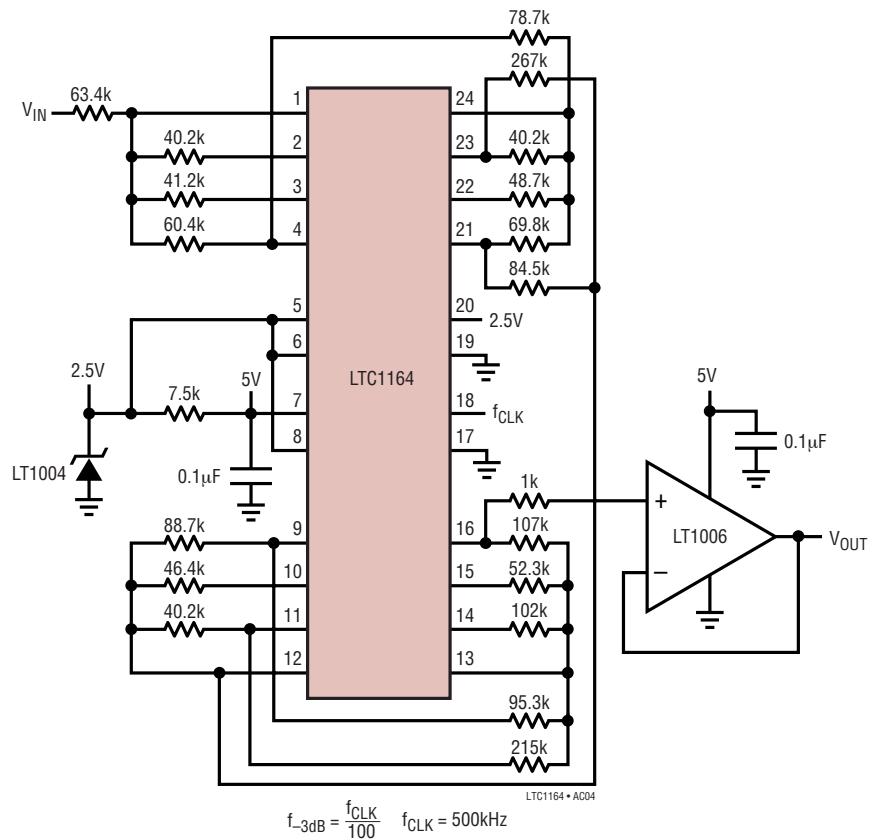
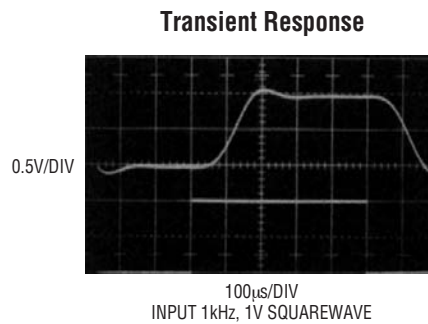
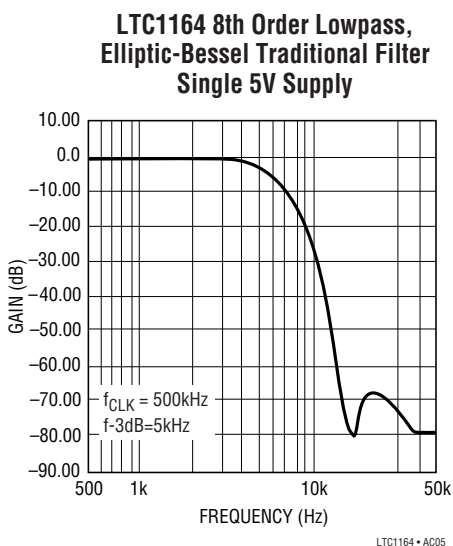


Figure 12. 8th Order Lowpass Single Supply Elliptic-Bessel Transitional Filter
Total Supply Current = 4mA, Passband Noise 50µV_{RMS}



TYPICAL APPLICATIONS

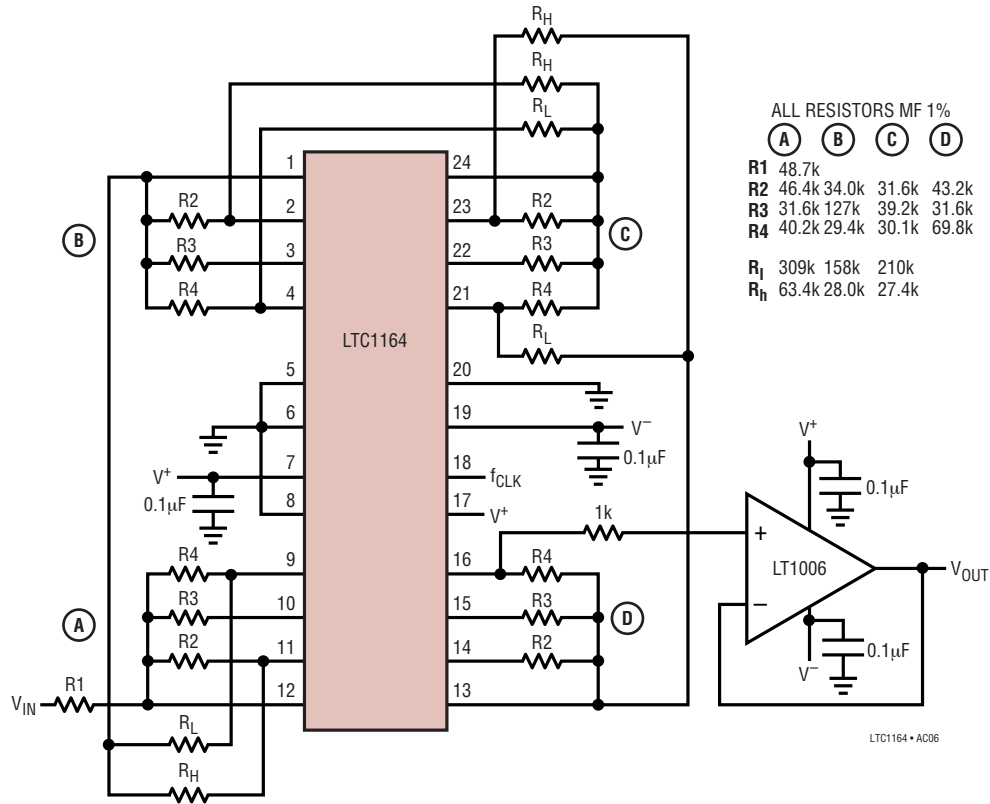


Figure 13. LTC1164 8th Order Lowpass Elliptic, $f_{CUTOFF} = 5\text{kHz}$, $f_{CLK} = 250\text{kHz}$, -78dB at 10kHz , Passband Noise = $110\mu\text{V}_{RMS} \pm 5\text{V}$ (Also Refer to the LTC1164-6)

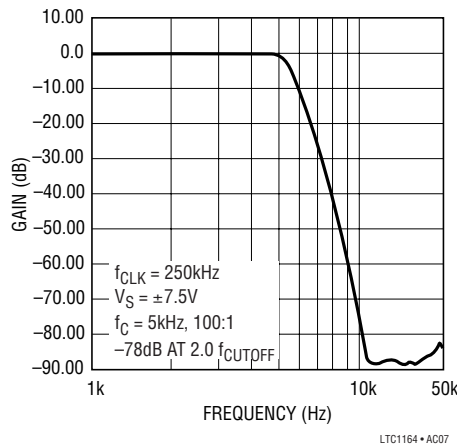
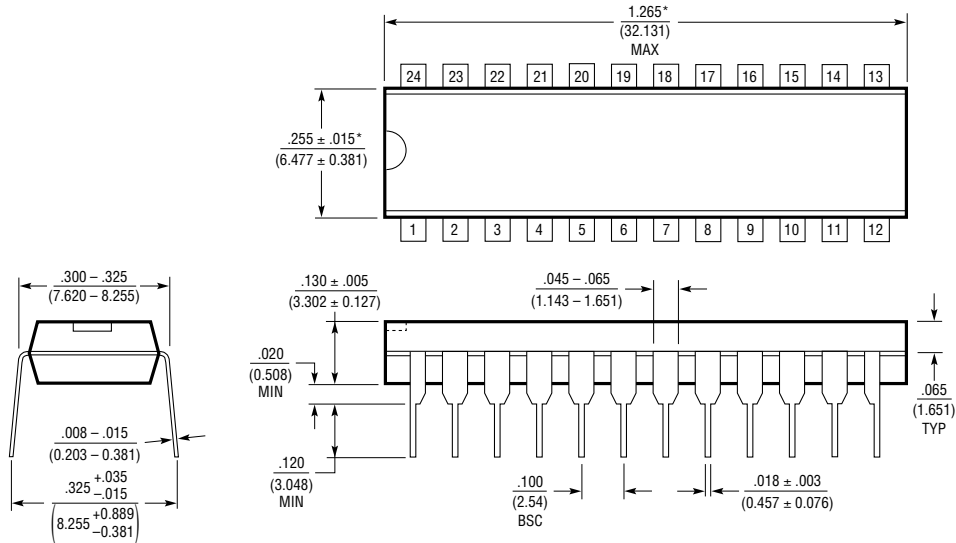


Figure 14. LTC1164 8th Order Lowpass Elliptic, $f_{CUTOFF} = 5\text{kHz}$

PACKAGE DESCRIPTION

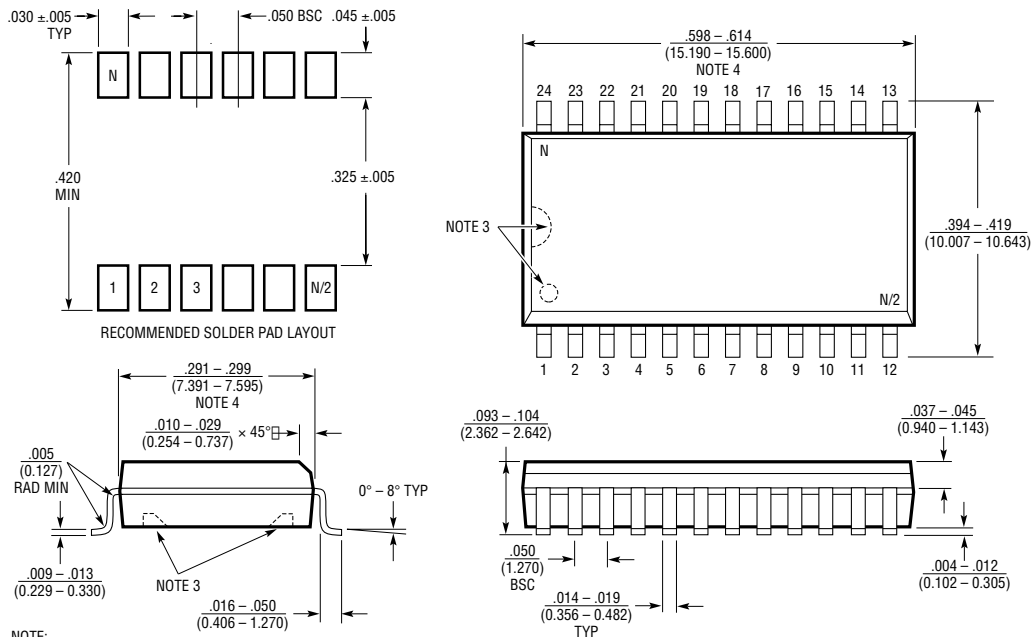
N Package
24-Lead PDIP (Narrow .300 Inch)
 (Reference LTC DWG # 05-08-1510)



NOTE:
 1. DIMENSIONS ARE IN INCHES (MILLIMETERS)
 *THESE DIMENSIONS DO NOT INCLUDE MOLD FLASH OR PROTRUSIONS.
 MOLD FLASH OR PROTRUSIONS SHALL NOT EXCEED .010 INCH (0.254mm)

N24 1002

SW Package
24-Lead Plastic Small Outline (Wide .300 Inch)
 (Reference LTC DWG # 05-08-1620)



NOTE:
 1. DIMENSIONS IN INCHES (MILLIMETERS)
 2. DRAWING NOT TO SCALE
 3. PIN 1 IDENT. NOTCH ON TOP AND CAVITIES ON THE BOTTOM OF PACKAGES ARE THE MANUFACTURING OPTIONS. THE PART MAY BE SUPPLIED WITH OR WITHOUT ANY OF THE OPTIONS
 4. THESE DIMENSIONS DO NOT INCLUDE MOLD FLASH OR PROTRUSIONS.
 MOLD FLASH OR PROTRUSIONS SHALL NOT EXCEED .006" (0.15mm)

S24 (WIDE) 0502

Looking for pricing, stock, or lifecycle information?

Click below to explore more details on WIN SOURCE:

 [View LTC1164CSW#TRPBF on WIN SOURCE](#)

 [Linear Technology](#) Information

Optimize Your Supply Chain with WIN SOURCE Solutions

-  Global Sourcing Solution
-  Obsolete Management
-  Cost Control Management
-  Shortage Management
-  Alternative Solution
-  Excess Inventory Management