



## FEATURES

- Lowpass Filter with No DC Error
- Low Passband Noise
- Operates DC to 20kHz
- Operates On a Single 5V Supply or Up to  $\pm 8V$
- 5th Order Filter
- Maximally Flat Response
- Internal or External Clock
- Cascadable for Faster Rolloff
- Buffer Available

## APPLICATIONS

- 60Hz Lowpass Filters
- Antialiasing Filter
- Low Level Filtering
- Rolling Off AC Signals from High DC Voltages
- Digital Voltmeters
- Scales
- Strain Gauges

## DESCRIPTION

The LTC<sup>®</sup>1062 is a 5th order all pole maximally flat lowpass filter with no DC error. Its unusual architecture puts the filter outside the DC path so DC offset and low frequency noise problems are eliminated. This makes the LTC1062 very useful for lowpass filters where DC accuracy is important.

The filter input and output are simultaneously taken across an external resistor. The LTC1062 is coupled to the signal through an external capacitor. This RC reacts with the internal switched capacitor network to form a 5th order rolloff at the output.

The filter cutoff frequency is set by an internal clock that can be externally driven. The clock-to-cutoff frequency ratio is typically 100:1, allowing the clock ripple to be easily removed.

Two LTC1062s can be cascaded to form a 10th order quasi max flat lowpass filter. The device can be operated with single or dual supplies ranging from  $\pm 2.5V$  to  $\pm 9V$ .

The LTC1062 is manufactured using Linear Technology's enhanced LTCMOS<sup>™</sup> silicon gate process.

**LT**, LTC and LT are registered trademarks of Linear Technology Corporation.  
 LTCMOS is a trademark of Linear Technology Corporation.

## TYPICAL APPLICATION

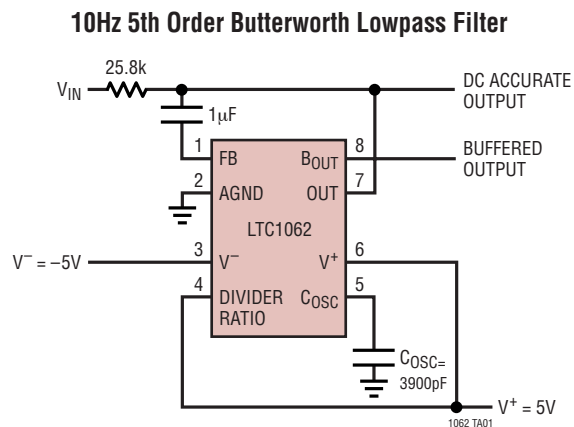

NOTE: TO ADJUST OSCILLATOR FREQUENCY, USE A 6800pF CAPACITOR IN SERIES WITH A 50k POT FROM PIN 5 TO GROUND

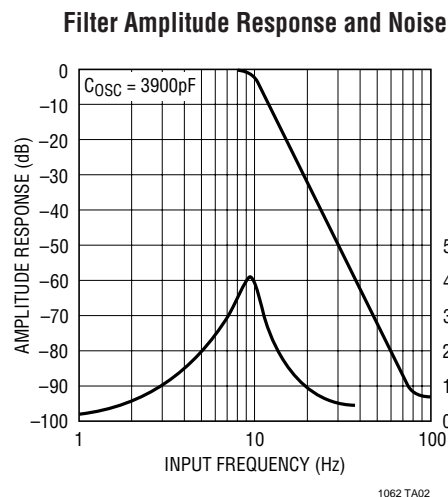

1062 TA02

1062fd

## ABSOLUTE MAXIMUM RATINGS (Note 1)

Total Supply Voltage ( $V^+$ to $V^-$ ) .....	18V	Storage Temperature Range .....	-65°C to 150°C
Input Voltage at Any Pin ..... $V^- - 0.3V \leq V_{IN} \leq V^+ + 0.3V$		Lead Temperature (Soldering, 10 sec).....	300°C
Operating Temperature Range			
LTC1062M (OBSOLETE) .....	$-55^\circ\text{C} \leq T_A \leq 125^\circ\text{C}$		
LTC1062C .....	$-40^\circ\text{C} \leq T_A \leq 85^\circ\text{C}$		

## PACKAGE/ORDER INFORMATION

<p>TOP VIEW</p> <p>N8 PACKAGE 8-LEAD PDIP</p> <p><math>T_{J\text{ MAX}} = 100^\circ\text{C}</math>, <math>\theta_{JA} = 130^\circ\text{C/W}</math></p>	<p>ORDER PART NUMBER</p>	<p>TOP VIEW</p> <p>SW PACKAGE 16-LEAD PLASTIC SO</p> <p><math>T_{J\text{ MAX}} = 150^\circ\text{C}</math>, <math>\theta_{JA} = 90^\circ\text{C/W}</math></p>	<p>ORDER PART NUMBER</p>
<p>J8 PACKAGE 8-LEAD CERDIP</p> <p><math>T_{J\text{ MAX}} = 150^\circ\text{C}</math>, <math>\theta_{JA} = 100^\circ\text{C/W}</math></p> <p><b>OBSOLETE PACKAGE</b> Consider the N8 Package as an Alternate Source</p>	<p>LTC1062CN8</p> <hr/> <p>LTC1062MJ8 LTC1062CJ8</p>		<p>LTC1062CSW</p>

Consult LTC Marketing for parts specified with wider operating temperature ranges.

## ELECTRICAL CHARACTERISTICS

The ● denotes specifications which apply over the full operating temperature range, otherwise specifications are at  $T_A = 25^\circ\text{C}$ .  $V^+ = 5\text{V}$ ,  $V^- = -5\text{V}$ , unless otherwise specified. AC output measured at Pin 7, Figure 1.

PARAMETER	CONDITIONS	MIN	TYP	MAX	UNITS
Power Supply Current	$C_{OSC}$ (Pin 5 to $V^-$ , Pin 11 in SW16) = 100pF	●	4.5	7 10	mA mA
Input Frequency Range			0 to 20		kHz
Filter Gain at $f_{IN} = 0$	$f_{CLK} = 100\text{kHz}$ , Pin 4 (Pin 6 in SW16) at $V^+$ , $C = 0.01\mu\text{F}$ , $R = 25.78\text{k}$		0.00		dB
$f_{IN} = 0.5f_C$ (Note 2)			-0.02	-0.3	dB
$f_{IN} = f_C$		●	-2	-3.00	dB
$f_{IN} = 2f_C$		●	-28	-30.00	dB
$f_{IN} = 4f_C$		●	-52	-60.00	dB
Clock-to-Cutoff Frequency Ratio, $f_{CLK}/f_C$	$f_{CLK} = 100\text{kHz}$ , Pin 4 (Pin 6 in SW16) at $V^+$ , $C = 0.01\mu\text{F}$ , $R = 25.78\text{k}$		100 ±1		%
Filter Gain at $f_{IN} = 16\text{kHz}$	$f_{CLK} = 400\text{kHz}$ , Pin 4 at $V^+$ , $C = 0.01\mu\text{F}$ , $R = 6.5\text{k}$	●	-43	-52	dB
$f_{CLK}/f_C$ Tempco	$f_{CLK} = 400\text{kHz}$ , Pin 4 at $V^+$ , $C = 0.01\mu\text{F}$ , $R = 6.5\text{k}$		10		ppm/°C
Filter Output (Pin 7, Pin 13 in SW16) DC Swing	Pin 7/Pin13 (SW16) Buffered with an External Op Amp	●	±3.5	±3.8	V
Clock Feedthrough			1		mV <sub>p-p</sub>

**ELECTRICAL CHARACTERISTICS** The ● denotes specifications which apply over the full operating temperature range, otherwise specifications are at  $T_A = 25^\circ\text{C}$ .  $V^+ = 5\text{V}$ ,  $V^- = -5\text{V}$ , unless otherwise specified, AC output measured at Pin 7, Figure 1.

PARAMETER	CONDITIONS	MIN	TYP	MAX	UNITS
<b>Internal Buffer</b>					
Bias Current		●	2 170	50 1000	$\mu\text{A}$ $\mu\text{A}$
Offset Voltage			2	20	mV
Voltage Swing	$R_{\text{LOAD}} = 20\text{k}$	●	$\pm 3.5$	$\pm 3.8$	V
Short-Circuit Current Source/Sink			40/3		mA
<b>Clock (Note 3)</b>					
Internal Oscillator Frequency	$C_{\text{OSC}}$ (Pin 5 to $V^-$ , Pin 11 in SW16) = 100pF	●	25 15	32 65	kHz kHz
Max Clock Frequency			4		MHz
Pin 5 (Pin 11 in SW16) Source or Sink Current		●	40	80	$\mu\text{A}$

**Note 1:** Absolute Maximum Ratings are those values beyond which the life of a device may be impaired.

**Note 2:**  $f_C$  is the frequency where the gain is  $-3\text{dB}$  with respect to the input signal.

**Note 3:** The external or driven clock frequency is divided by either 1, 2 or 4 depending upon the voltage at Pin 4. For the N8 package, when Pin 4 =  $V^+$ , ratio = 1; when Pin 4 = GND, ratio = 2; when Pin 4 =  $V^-$ , ratio = 4.

**TYPICAL PERFORMANCE CHARACTERISTICS**

Amplitude Response Normalized to the Cutoff Frequency

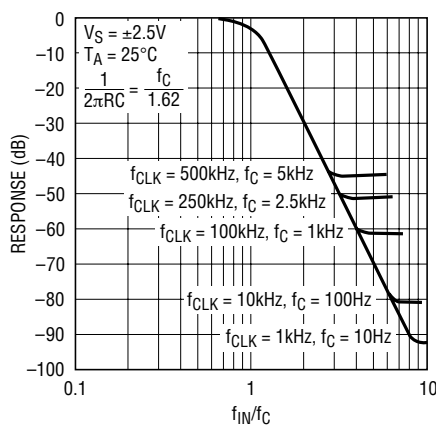

1062 G01

Amplitude Response Normalized to the Cutoff Frequency

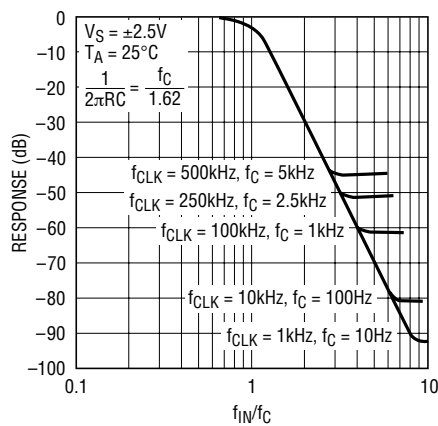

1062 G01

Passband Gain vs Input Frequency

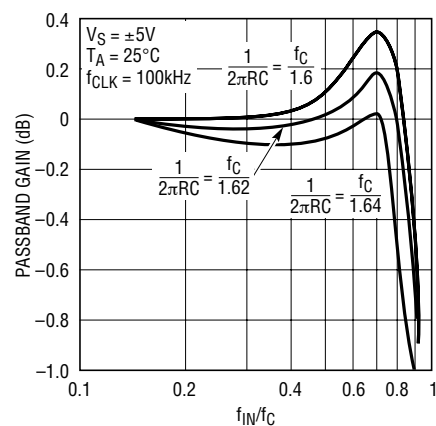

1062 G03

# TYPICAL PERFORMANCE CHARACTERISTICS

**Passband Gain vs Input Frequency and Temperature**

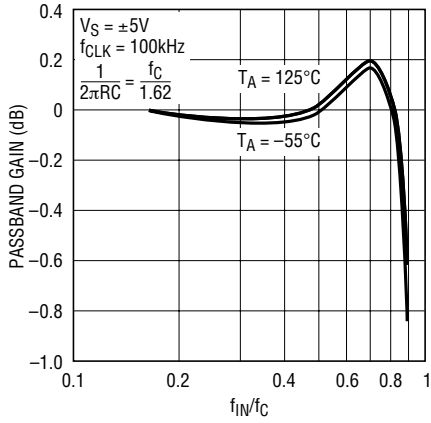

1062 G04

**Passband Phase Shift vs Input Frequency**

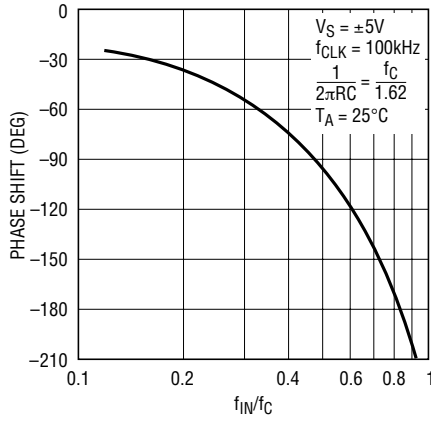

1062 G05

**Filter Noise Spectral Density**

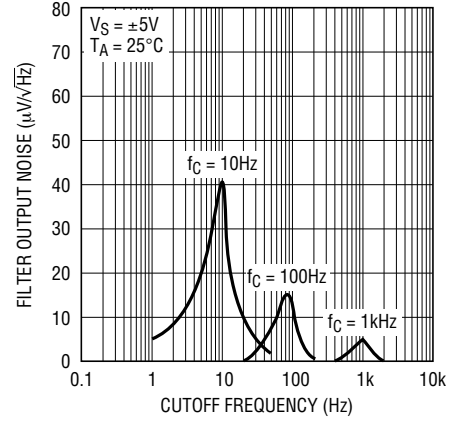

1062 G06

**Normalized Oscillator Frequency, f\_OSC vs Supply Voltage**

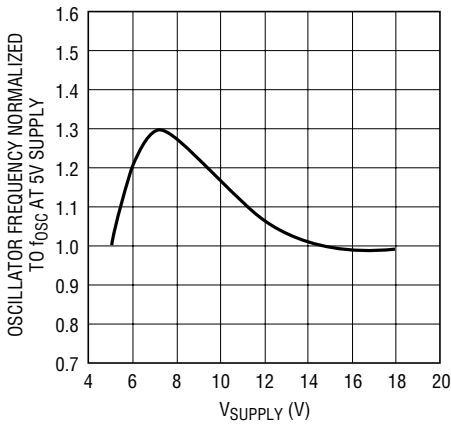

1062 G07

**Oscillator Frequency, f\_OSC vs Ambient Temperature**

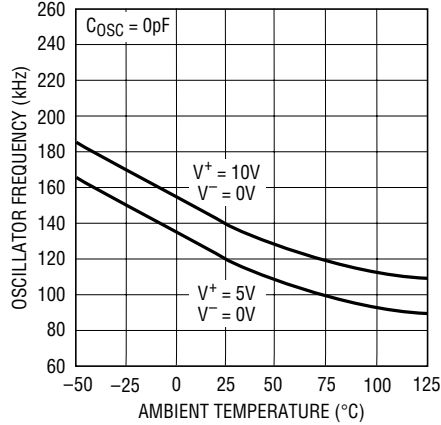

1062 G08

**Power Supply Current vs Power Supply Voltage**

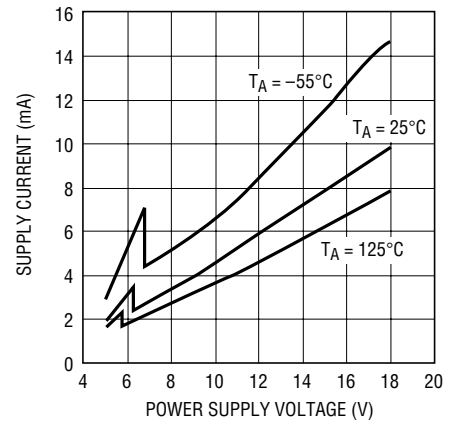

1062 G09

## BLOCK DIAGRAM

For Adjusting Oscillator Frequency, Insert a 50k Pot in Series with C<sub>OSC</sub>. Use Two Times Calculated C<sub>OSC</sub>

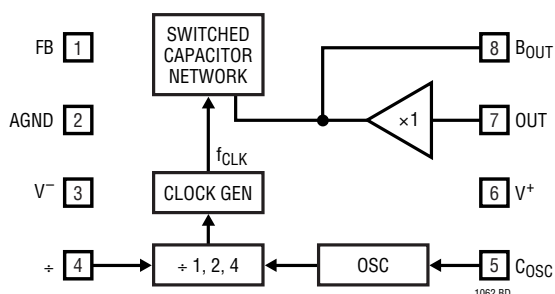

BY CONNECTING PIN 4 TO V<sup>+</sup>, AGND OR V<sup>-</sup>, THE OUTPUT FREQUENCY OF THE INTERNAL CLOCK GENERATOR IS THE OSCILLATOR FREQUENCY DIVIDED BY 1, 2, 4. THE (f<sub>CLK</sub>/f<sub>C</sub>) RATIO OF 100:1 IS WITH RESPECT TO THE INTERNAL CLOCK GENERATOR OUTPUT FREQUENCY. PIN 5 CAN BE DRIVEN WITH AN EXTERNAL CMOS LEVEL CLOCK. THE LTC1062 CAN ALSO BE SELF-CLOCKED BY CONNECTING AN EXTERNAL CAPACITOR (C<sub>OSC</sub>) TO GROUND (OR TO V<sup>-</sup> IF C<sub>OSC</sub> IS POLARIZED). UNDER THIS CONDITION AND WITH ±5V SUPPLIES, THE INTERNAL OSCILLATOR FREQUENCY IS:

$$f_{OSC} = 140\text{kHz} [33\text{pF}/(33\text{pF} + C_{OSC})]$$

## AC TEST CIRCUIT

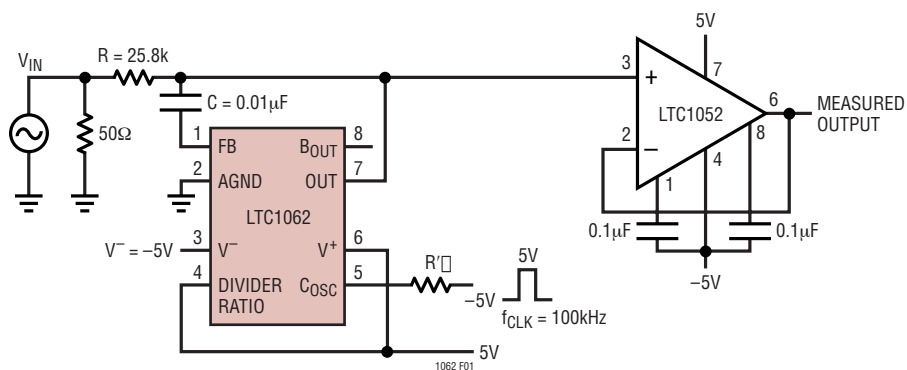

FOR BEST MAX FLAT APPROXIMATION, THE INPUT RC SHOULD BE SUCH AS:

$$\frac{1}{2\pi RC} = \frac{f_{CLK}}{100} \cdot \frac{1}{1.63}$$

A 0.5k RESISTOR, R', SHOULD BE USED IF THE BIPOLAR EXTERNAL CLOCK IS APPLIED BEFORE THE POWER SUPPLIES TURN ON

Figure 1

## APPLICATIONS INFORMATION

### Filter Input Voltage Range

Every node of the LTC1062 typically swings within 1V of either voltage supply, positive or negative. With the appropriate external (RC) values, the amplitude response of all the internal or external nodes does not exceed a gain of 0dB with the exception of Pin 1. The amplitude response of the feedback node (Pin 1) is shown in Figure 2. For an input frequency around  $0.8 \cdot f_C$ , the gain is 1.7V/V and, with  $\pm 5V$  supplies, the peak-to-peak input voltage should not exceed 4.7V. If the input voltage goes beyond this value, clipping and distortion of the output waveform occur, but the filter will not get damaged nor will it oscillate. Also, the absolute maximum input voltage should not exceed the power supplies.

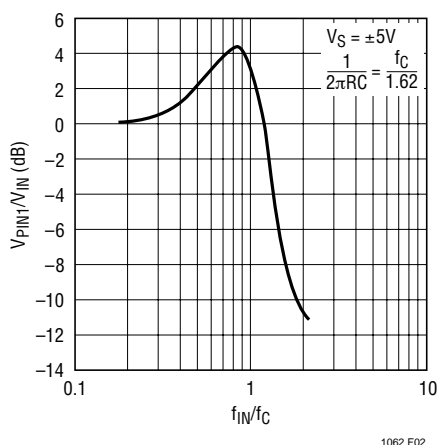

Figure 2. Amplitude Response of Pin 1

### Internal Buffer

The internal buffer out (Pin 8) and Pin 1 are part of the signal AC path. Excessive capacitive loading will cause gain errors in the passband, especially around the cutoff frequency. The internal buffer gain at DC is typically 0.006dB. The internal buffer output can be used as a filter output, however, it has a few millivolts of DC offset. The temperature coefficient of the internal buffer is typically  $1\mu V/^\circ C$ .

### Filter Attenuation

The LTC1062 rolloff is typically 30dB/octave. When the clock and the cutoff frequencies increase, the filter's maximum attenuation decreases. This is shown in the

Typical Performance Characteristics. The decrease of the maximum attenuation is due to the rolloff at higher frequencies of the loop gains of the various internal feedback paths and not to the increase of the noise floor. For instance, for a 100kHz clock and 1kHz cutoff frequency, the maximum attenuation is about 64dB. A 4kHz,  $1V_{RMS}$  input signal will be predictably attenuated by 60dB at the output. A 6kHz,  $1V_{RMS}$  input signal will be attenuated by 64dB and not by 77dB as an ideal 5th order maximum flat filter would have dictated. The LTC1062 output at 6kHz will be about  $630\mu V_{RMS}$ . The measured RMS noise from DC to 17kHz was  $100\mu V_{RMS}$  which is 16dB below the filter output.

### C<sub>OSC</sub>, Pin 5

The C<sub>OSC</sub>, Pin 5, can be used with an external capacitor, C<sub>OSC</sub>, connected from Pin 5 to ground. If C<sub>OSC</sub> is polarized it should be connected from Pin 5 to the negative supply, Pin 3. C<sub>OSC</sub> lowers the internal oscillator frequency. If Pin 5 is floating, an internal 33pF capacitor plus the external interpin capacitance set the oscillator frequency around 140kHz with  $\pm 5V$  supply. An external C<sub>OSC</sub> will bring the oscillator frequency down by the ratio  $(33pF)/(33pF + C_{OSC})$ . The Typical Performance Characteristics curves provide the necessary information to get the internal oscillator frequency for various power supply ranges. Pin 5 can also be driven with an external CMOS clock to override the internal oscillator. Although standard 7400 series CMOS gates do not guarantee CMOS levels with the current source and sink requirements of Pin 5, they will, in reality, drive the C<sub>OSC</sub> pin. CMOS gates conforming to standard B series output drive have the appropriate voltage levels and more than enough output current to simultaneously drive several LTC1062 C<sub>OSC</sub> pins. The typical trip levels of the internal Schmitt trigger which input is Pin 5, are given in Table 1.

Table 1

V <sub>SUPPLY</sub>	V <sub>TH</sub> <sup>+</sup>	V <sub>TH</sub> <sup>-</sup>
±2.5V	0.9V	-1V
±5V	1.3V	-2.1V
±6V	1.7V	-2.5V
±7V	1.75V	-2.9V

## APPLICATIONS INFORMATION

### Divide By 1, 2, 4 (Pin 4)

By connecting Pin 4 to  $V^+$ , to mid supplies or to  $V^-$ , the clock frequency driving the internal switched capacitor network is the oscillator frequency divided by 1, 2, 4 respectively. Note that the  $f_{CLK}/f_C$  ratio of 100:1 is with respect to the internal clock generator output frequency. The internal divider is useful for applications where octave tuning is required. The  $\pm 2$  threshold is typically  $\pm 1V$  from the mid supply voltage.

### Transient Response

Figure 3 shows the LTC1062 response to a 1V input step.

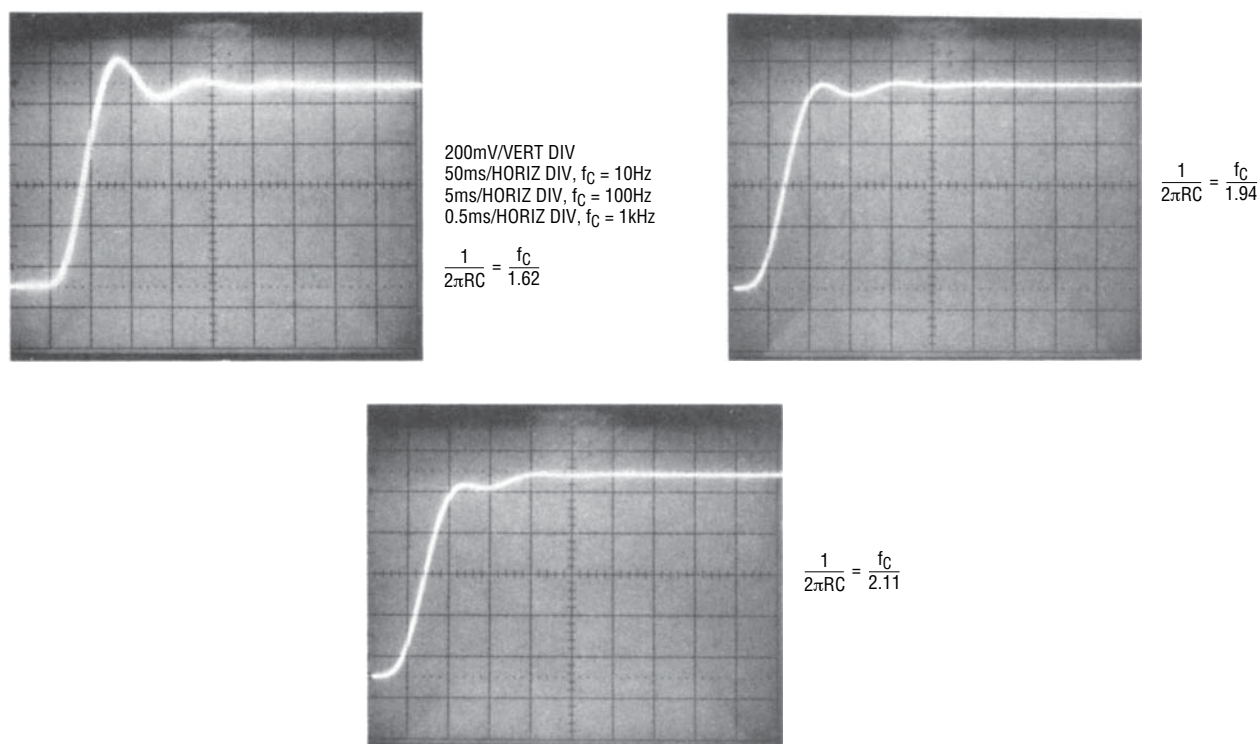

Figure 3. Step Response to a 1V Peak Input Step

Table 2

NOISE BW	RMS NOISE ( $V_S = \pm 5V$ )
DC – $0.1 \cdot f_C$	$2\mu V$
DC – $0.25 \cdot f_C$	$8\mu V$
DC – $0.5 \cdot f_C$	$20\mu V$
DC – $1 \cdot f_C$	$62\mu V$
DC – $2 \cdot f_C$	$100\mu V$

TYPICAL APPLICATIONS

AC Coupling an External CMOS Clock Powered from a Single Positive Supply, V<sup>+</sup>

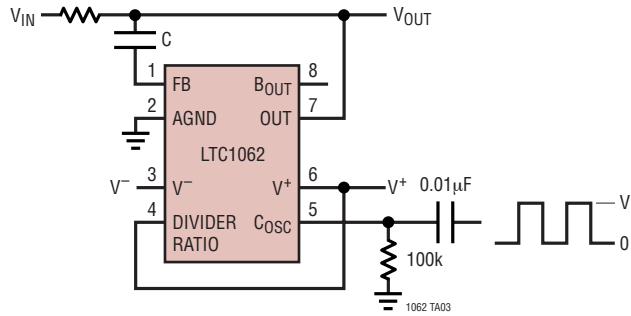

Adding an External (R1, C1) to Eliminate the Clock Feedthrough and to Improve the High Frequency Attenuation Floor

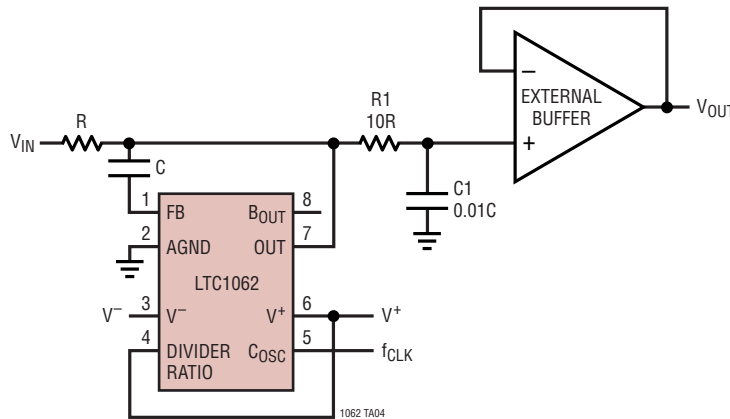

Filtering AC Signals from High DC Voltages

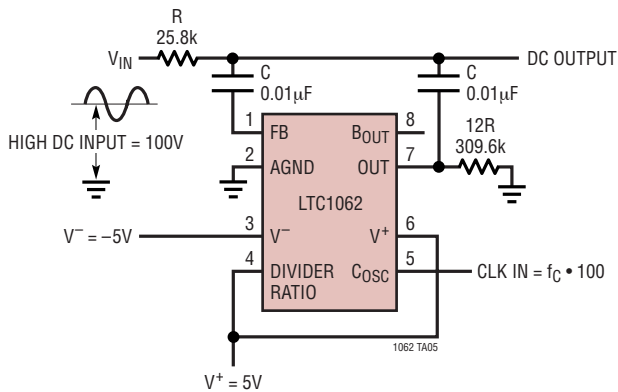

EXAMPLE:  
 $f_{CLK} = 100\text{kHz}$ ,  $f_C = 1\text{kHz}$ . THE FILTER ACCURATELY PASSES THE HIGH DC INPUT AND ACTS AS 5TH ORDER LP FILTER FOR THE AC SIGNALS RIDING ON THE DC

Passband Amplitude Response for the High DC Accurate 5th Order Filter

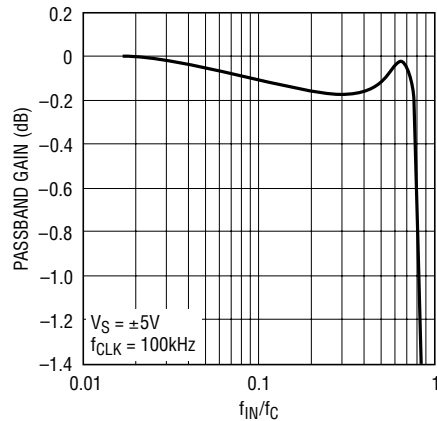

1062 TA06

# TYPICAL APPLICATIONS

**Cascading Two LTC1062s to Form a Very Selective Clock Sweepable Bandpass Filter**

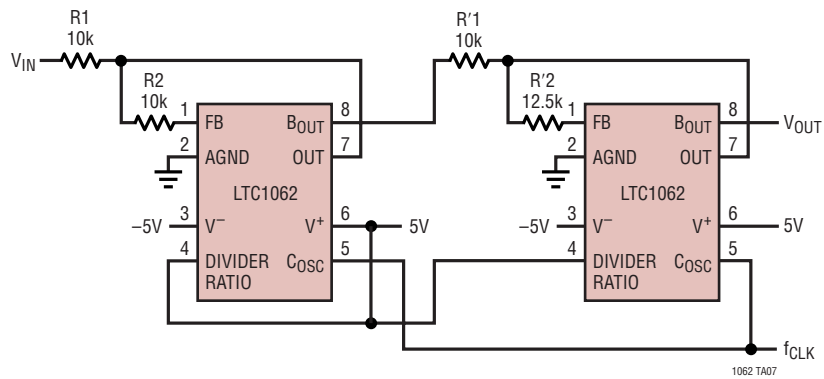

**Clock Tunable Notch Filter**  
For Simplicity Use  $R3 = R4 = R5 = 10k$ ;

$$\frac{R5}{R2} = 1.234, \frac{f_{CLK}}{f_{NOTCH}} = \frac{79.3}{1}$$

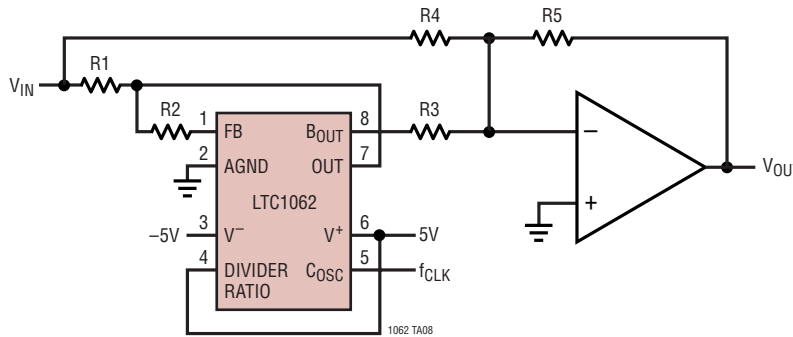

**Frequency Response of the Bandpass Filter**

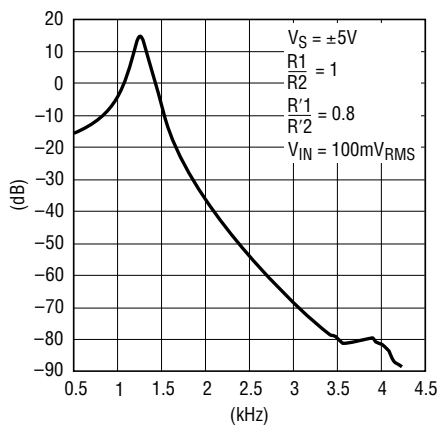

1062 TA09

**Frequency Response of the Notch Filter**

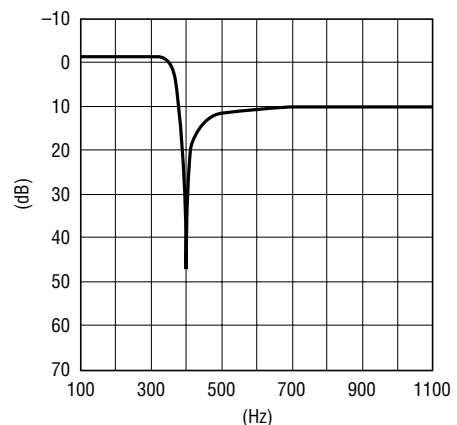

1062 TA10

TYPICAL APPLICATIONS

Simple Cascading Technique

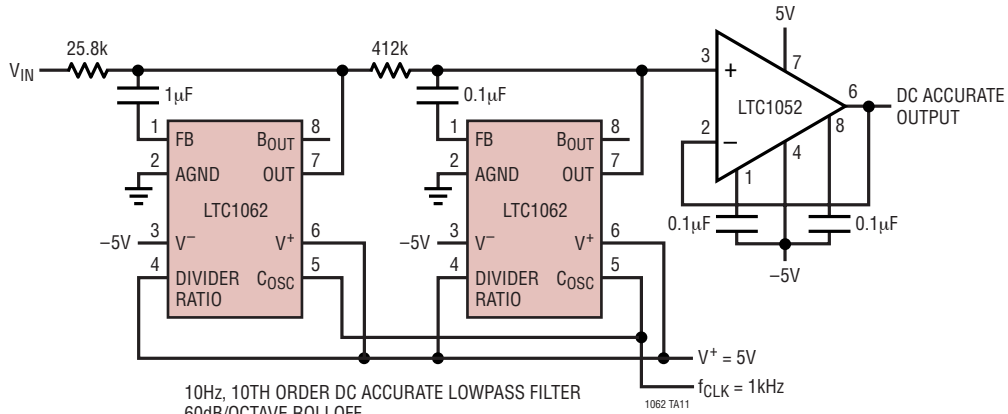

10Hz, 10TH ORDER DC ACCURATE LOWPASS FILTER  
 60dB/OCTAVE ROLLOFF  
 0.5dB PASSBAND ERROR, 0dB DC GAIN  
 MAXIMUM ATTENUATION 110dB ( $f_{CLK} = 10kHz$ )  
 100dB ( $f_{CLK} = 1kHz$ )  
 95dB ( $f_{CLK} = 1MHz$ )

100Hz, 50Hz, 25Hz 5th Order DC Accurate LP Filter

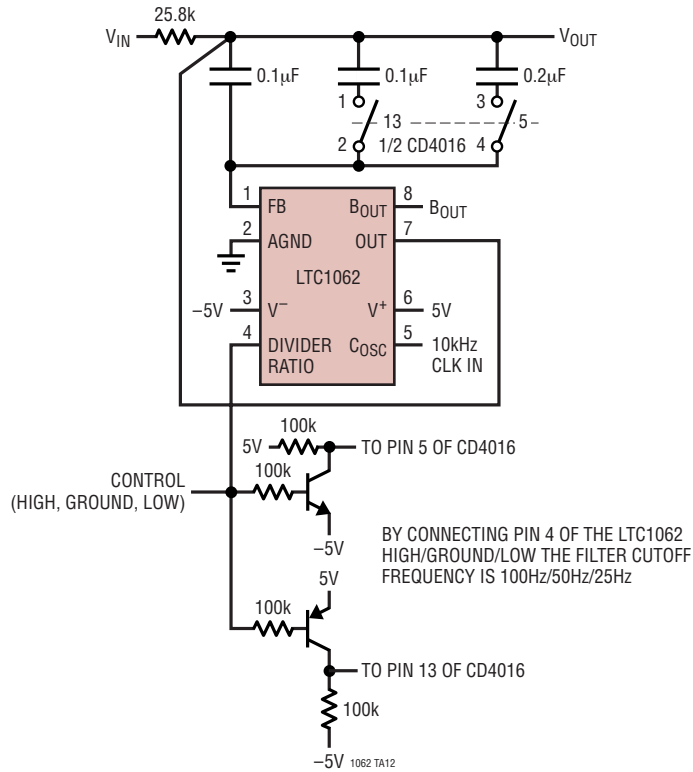

## TYPICAL APPLICATIONS

### 7th Order 100Hz Lowpass Filter with Continuous Output Filtering, Output Buffering and Gain Adjustment

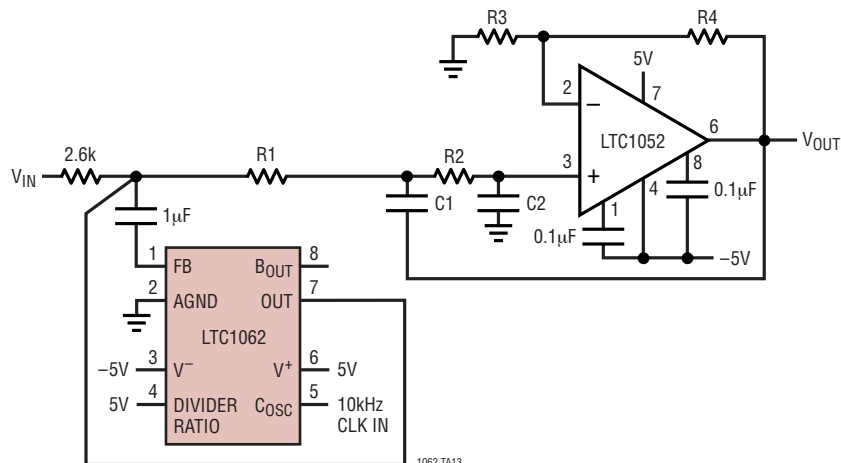

THE LTC1052 IS CONNECTED AS A 2ND ORDER SALLEN KEY LOWPASS FILTER WITH A CUTOFF FREQUENCY EQUAL TO THE CUTOFF FREQUENCY OF THE LTC1062. THE ADDITIONAL FILTERING ELIMINATES ANY 10kHz CLOCK FEEDTHROUGH PLUS DECREASES THE WIDEBAND NOISE OF THE FILTER  
 DC OUTPUT OFFSET (REFERRED TO A DC GAIN OF UNITY) = 5 $\mu$ V MAX  
 WIDEBAND NOISE (REFERRED TO A DC GAIN OF UNITY) = 60 $\mu$ V<sub>RMS</sub>

#### OUTPUT FILTER COMPONENT VALUES

DC GAIN	R3	R4	R1	R2	C1	C2
1	$\infty$	0	14.3k	53.6k	0.1 $\mu$ F	0.033 $\mu$ F
10	3.57k	32.4k	46k	274k	0.01 $\mu$ F	0.02 $\mu$ F

### Single 5V Supply 5th Order LP Filter

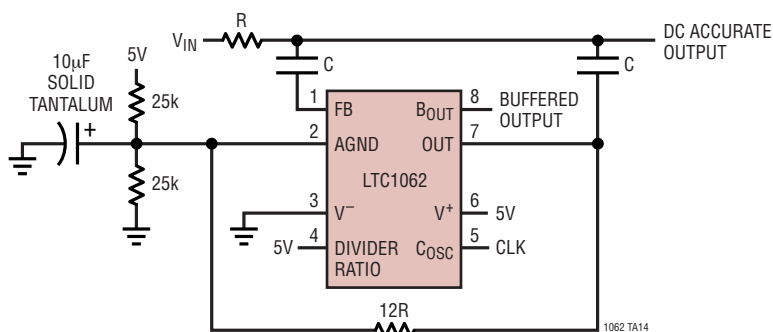

FOR A 10Hz FILTER: R = 29.4k, C = 1 $\mu$ F,  $f_{CLK}$  = 1kHz  
 THE FILTER IS MAXIMALLY FLAT FOR  $\frac{1}{2\pi RC} = \frac{f_c}{1.84}$

TYPICAL APPLICATIONS

A Lowpass Filter with a 60Hz Notch

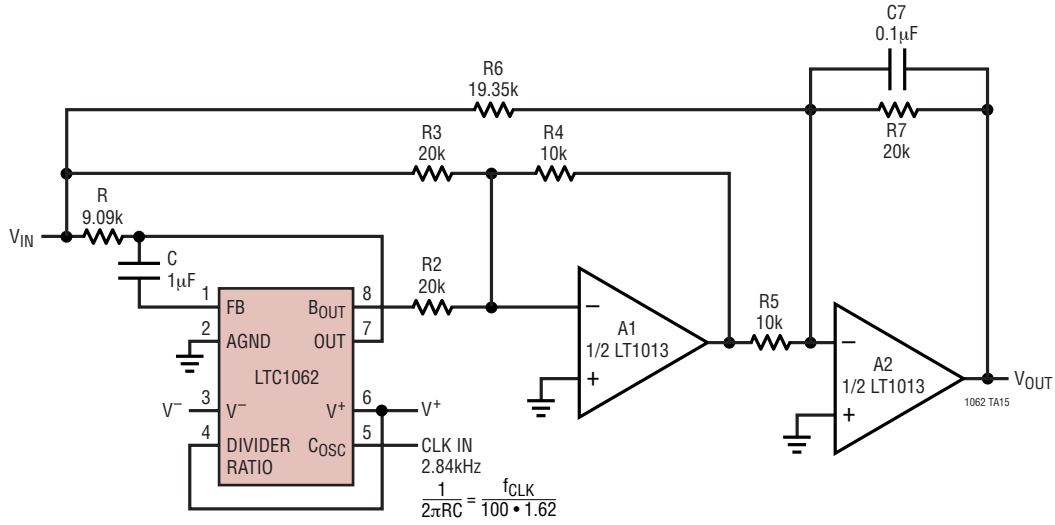

Frequency Response of the Above Lowpass Filter with the Notch  $f_{NOTCH} = f_{CLK}/47.3$

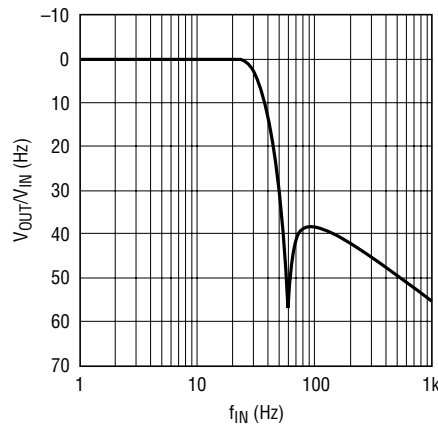

**PACKAGE DESCRIPTION**

**J8 Package**  
**8-Lead CERDIP (Narrow .300 Inch, Hermetic)**  
 (Reference LTC DWG # 05-08-1110)

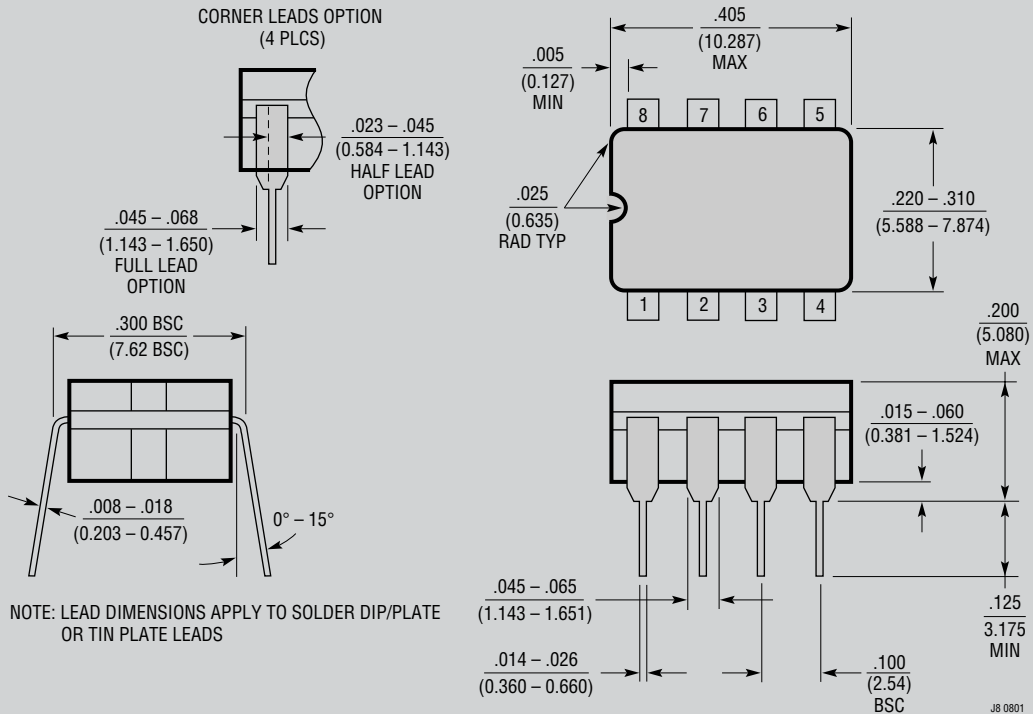

NOTE: LEAD DIMENSIONS APPLY TO SOLDER DIP/PLATE OR TIN PLATE LEADS

**OBsolete PACKAGE**

J8 0801

**PACKAGE DESCRIPTION**

**N8 Package**  
**8-Lead PDIP (Narrow .300 Inch)**  
 (Reference LTC DWG # 05-08-1510)

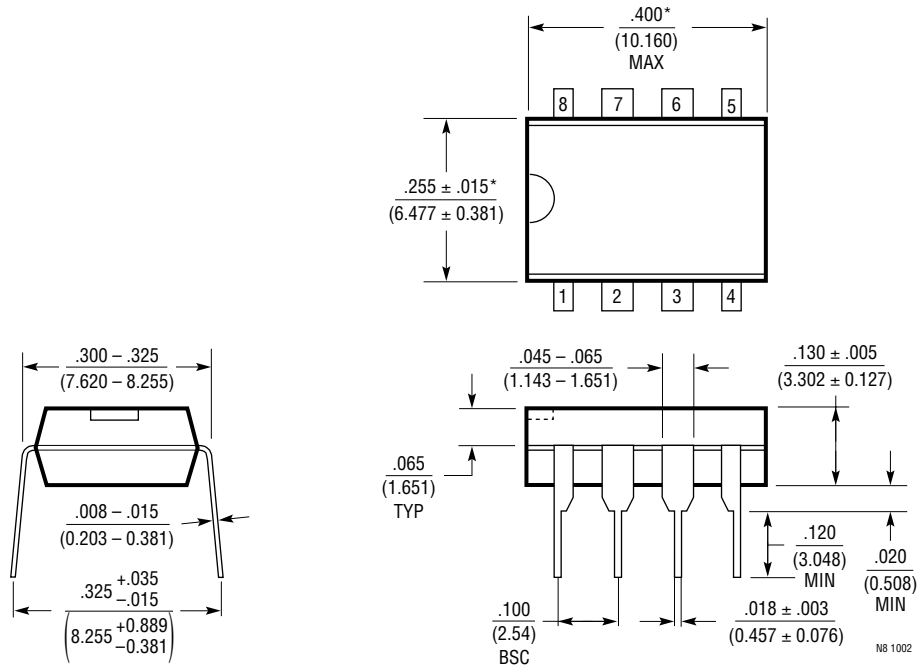

NOTE:  
 1. DIMENSIONS ARE  $\frac{\text{INCHES}}{\text{MILLIMETERS}}$   
 \*THESE DIMENSIONS DO NOT INCLUDE MOLD FLASH OR PROTRUSIONS.  
 MOLD FLASH OR PROTRUSIONS SHALL NOT EXCEED .010 INCH (0.254mm)

# PACKAGE DESCRIPTION

## SW Package 16-Lead Plastic Small Outline (Wide .300 Inch) (Reference LTC DWG # 05-08-1620)

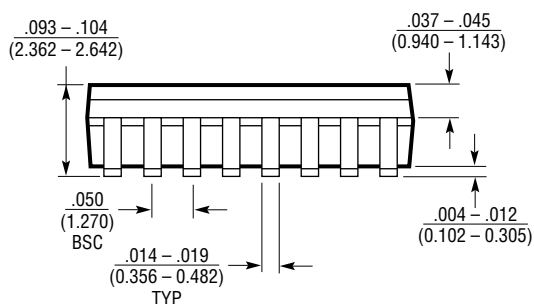
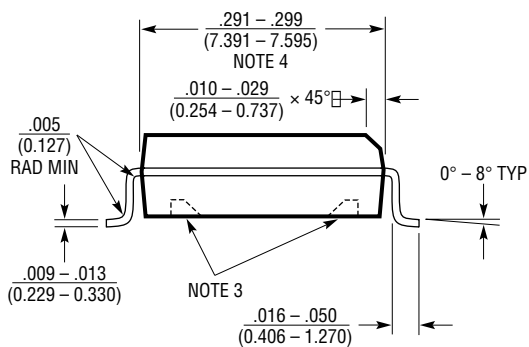
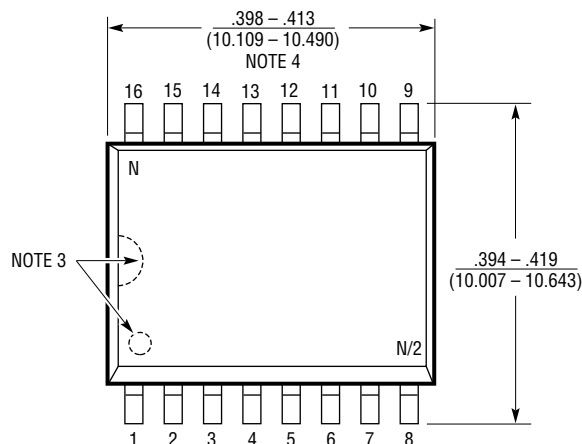
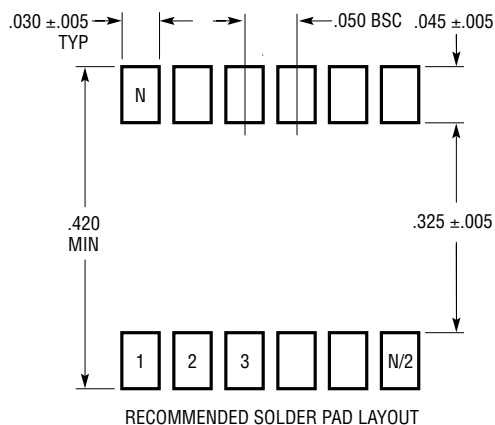

- NOTE:
1. DIMENSIONS IN  $\frac{\text{INCHES}}{\text{MILLIMETERS}}$
  2. DRAWING NOT TO SCALE
  3. PIN 1 IDENT, NOTCH ON TOP AND CAVITIES ON THE BOTTOM OF PACKAGES ARE THE MANUFACTURING OPTIONS. THE PART MAY BE SUPPLIED WITH OR WITHOUT ANY OF THE OPTIONS
  4. THESE DIMENSIONS DO NOT INCLUDE MOLD FLASH OR PROTRUSIONS. MOLD FLASH OR PROTRUSIONS SHALL NOT EXCEED  $.006''$  ( $0.15\text{mm}$ )

S16 (WIDE) 0502

## TYPICAL APPLICATION

A Low Frequency, 5Hz Filter Using Back-to-Back Solid Tantalum Capacitors

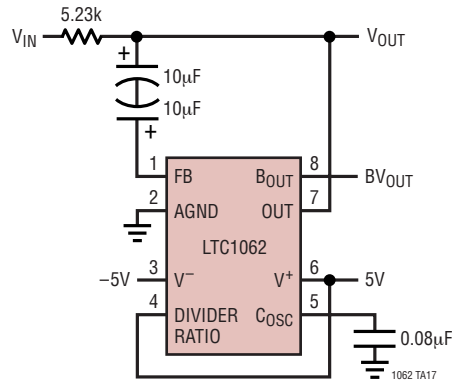

## RELATED PARTS

PART NUMBER	DESCRIPTION	COMMENTS
LTC1063	5th Order Butterworth Lowpass, DC Accurate	Clock Tunable, No External Components
LTC1065	5th Order Bessel Lowpass, DC Accurate	Clock Tunable, No External Components
LTC1066-1	8th Order Elliptic or Linear Phase, DC Accurate	Clock Tunable, $f_c \leq 120\text{kHz}$
LTC1563-2/ LTC1563-3	Active RC, 4th Order Lowpass	Very Low Noise, $256\text{Hz} \leq f_c \leq 256\text{kHz}$
LTC1564	10kHz to 150kHz Digitally Controlled Lowpass and PGA	Continuous Time, Very High Dynamic Range, PGA Included
LTC1569-6	Linear Phase, DC Accurate, 10th Order	No External Clock Required, $f_c \leq 64\text{kHz}$ , S08
LTC1569-7	Linear Phase, DC Accurate, 10th Order	No External Clock Required, $f_c \leq 300\text{kHz}$ , S08

## Looking for pricing, stock, or lifecycle information?

Click below to explore more details on WIN SOURCE:

 [View LTC1062CN8 on WIN SOURCE](#)

 [Linear Technology](#) Information

## Optimize Your Supply Chain with WIN SOURCE Solutions

-  Global Sourcing Solution
-  Obsolete Management
-  Cost Control Management
-  Shortage Management
-  Alternative Solution
-  Excess Inventory Management