



**THE DATASHEET OF
LT5521EUF#PBF**



FEATURES

- Wideband Output Frequency Range to 3.7GHz
- +24.2dBm IIP3 at 1.95GHz RF Output
- Low LO Leakage: -42dBm
- Integrated LO Buffer: Low LO Drive Level
- Single-Ended LO Drive
- Wide Single Supply Range: 3.15V to 5.25V
- Double-Balanced Active Mixer
- Shutdown Function
- 16-Lead (4mm × 4mm) QFN Package

APPLICATIONS

- Cellular, W-CDMA, PHS and UMTS Infrastructure
- Cable Downlink Infrastructure
- Wireless Infrastructure
- Fixed Wireless Access Equipment
- High Linearity Mixer Applications

DESCRIPTION

The LT[®]5521 is a very high linearity mixer optimized for low distortion and low LO leakage applications. The chip includes a high speed LO buffer with single-ended input and a double-balanced active mixer. The LT5521 requires only -5dBm LO input power to achieve excellent distortion and noise performance, while reducing external drive circuit requirements. The LO buffer is internally 50Ω matched for wideband operation.

With a 250MHz input, a 1.7GHz LO and a 1.95GHz output frequency, the mixer has a typical IIP3 of +24.2dBm, -0.5dB conversion gain and a 12.5dB noise figure.

The LT5521 offers exceptional LO-RF isolation, greatly reducing the need for output filtering to meet LO suppression requirements.

The device is designed to work over a supply voltage range from 3.15V to 5.25V.

LT, LTC and LT are registered trademarks of Linear Technology Corporation.

TYPICAL APPLICATION

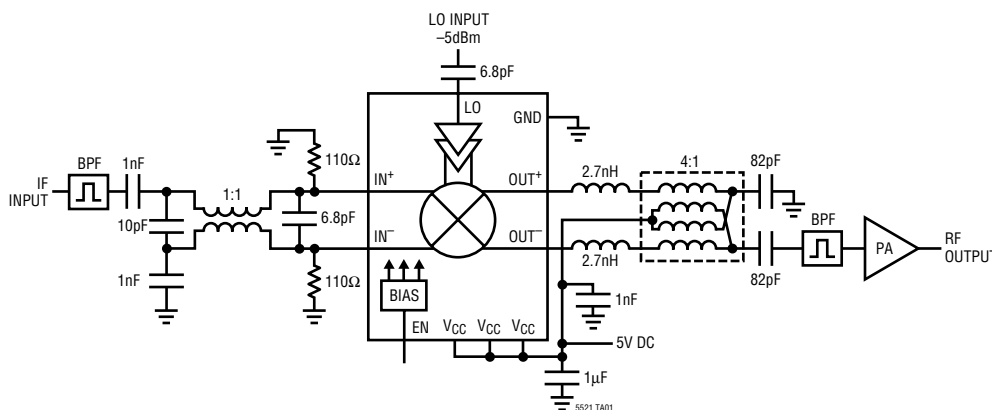

Fundamental, 3rd Order
 Intermodulation Distortion
 vs Input Power

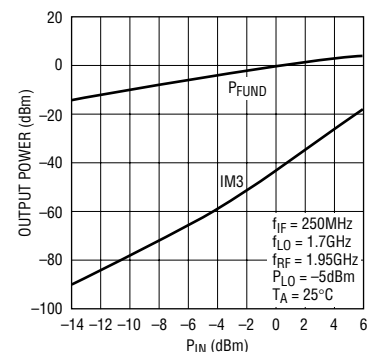

ABSOLUTE MAXIMUM RATINGS

(Note 1)

Power Supply Voltage	5.5V
Enable Voltage	-0.2V to $V_{CC} + 0.2V$
LO Input Power	+10dBm
LO Input DC Voltage	0V to 1.5V
IF Input Power	+10dBm
Difference Voltage Across Output Pins	$\pm 1.5V$
Maximum Pin 2 or Pin 3 Current	34mA
Operating Ambient Temperature Range ..	-40°C to 85°C
Storage Temperature Range	-65°C to 125°C
Maximum Junction Temperature	125°C

PACKAGE/ORDER INFORMATION

<p>TOP VIEW</p> <p>UF PACKAGE 16-LEAD (4mm x 4mm) PLASTIC QFN</p> <p>$T_{JMAX} = 125^{\circ}C$, $\theta_{JA} = 37^{\circ}C/W$ EXPOSED PAD (PIN 17) IS GND MUST BE SOLDERED TO PCB</p>	ORDER PART NUMBER
	LT5521EUF
	UF PART MARKING
	5521

Consult LTC Marketing for parts specified with wider operating temperature ranges.

DC ELECTRICAL CHARACTERISTICS $V_{CC} = 5V$, $EN = 2.9V$, $T_A = 25^{\circ}C$ unless otherwise noted.

Test circuit shown in Figure 1. (Note 2)

PARAMETER	CONDITIONS	MIN	TYP	MAX	UNITS
Supply Voltage		3.15		5.25	V
Supply Current			82	98	mA
Shutdown Current	$EN = 0.2V$		20	100	μA
Enable (EN) Low = Off, High = On					
Enable Mode	$EN = High$	2.9			V
Disable Mode	$EN = Low$			0.2	V
Enable Current	$EN = 5V$		137		μA
Shutdown Enable Current	$EN = 0.2V$		0.1		μA
Turn-On Time (Note 3)			200		ns
Turn-Off Time (Note 4)			200		ns
LO Voltage (Pin 15)	Internally Biased		0.96		V
Input Voltage (Pins 2, 3)	$V_{CC} = 5V$, Internally Biased $V_{CC} = 3.3V$, Internally Biased		2.20 0.46		V V

AC ELECTRICAL CHARACTERISTICS $V_{CC} = 5V$, $EN = 2.9V$, $T_A = 25^{\circ}C$ unless otherwise noted.

Test circuit shown in Figure 1. (Note 2)

PARAMETER	CONDITIONS	MIN	TYP	MAX	UNITS
LO Frequency Range			10 to 4000		MHz
Input Frequency Range			10 to 3000		MHz
Output Frequency Range			10 to 3700		MHz
LO Input Power			-5	1	dBm
LO Return Loss	$Z_0 = 50\Omega$, $f_{LO} = 1700MHz$		12		dB
Output Return Loss	Requires Matching		12		dB
Input Return Loss (Pins 2, 3)	Requires Matching		15		dB

AC ELECTRICAL CHARACTERISTICS

$V_{CC} = 5V$, $EN = 2.9V$, $f_{IF} = 250MHz$, $P_{IF} = -7dBm$, $f_{LO} = 1700MHz$, $P_{LO} = -5dBm$, $f_{RF} = 1950MHz$, $T_A = 25^\circ C$. Test circuit shown in Figure 1.

PARAMETER	CONDITIONS	MIN	TYP	MAX	UNITS
Conversion Gain			-0.5		dB
Conversion Gain Variation vs Temperature			-0.009		dB/°C
Input P1dB			+10		dBm
Single-Side Band Noise Figure			12.5		dB
IIP3	Two Tones, $\Delta f_{IF} = 5MHz$, $P_{IF} = -7dBm/Tone$		+24.2		dBm
IIP2 (Note 6)	Two Tones, $\Delta f_{IF} = 5MHz$, $P_{IF} = -7dBm/Tone$, $f_{LO} + f_{IF1} + f_{IF2}$		+49		dBm
LO-RF Leakage			-42		dBm
LO-IF Leakage			-40		dBm

$V_{CC} = 5V$, $EN = 2.9V$, $f_{IF} = 44MHz$, $P_{IF} = -7dBm$, $f_{LO} = 1001MHz$, $P_{LO} = -5dBm$, $f_{RF} = 1045MHz$, $T_A = 25^\circ C$.

PARAMETER	CONDITIONS	MIN	TYP	MAX	UNITS
Conversion Gain			-0.5		dB
Conversion Gain Variation vs Temperature			-0.012		dB/°C
Input P1dB			+10		dBm
Single-Side Band Noise Figure			12.8		dB
IIP3	Two Tones, $\Delta f_{IF} = 5MHz$, $P_{IF} = -7dBm/Tone$		+24.5		dBm
IIP2 (Note 6)	Two Tones, $\Delta f_{IF} = 5MHz$, $P_{IF} = -7dBm/Tone$, $f_{LO} + f_{IF1} + f_{IF2}$		+49		dBm
LO-RF Leakage			-38		dBm
LO-IF Leakage			-59		dBm

$V_{CC} = 3.3V$, $EN = 2.9V$, $f_{IF} = 250MHz$, $P_{IF} = -7dBm$, $f_{LO} = 1700MHz$, $P_{LO} = -5dBm$, $f_{RF} = 1950MHz$, $T_A = 25^\circ C$. (Note 5)

PARAMETER	CONDITIONS	MIN	TYP	MAX	UNITS
Conversion Gain			-0.5		dB
Conversion Gain Variation vs Temperature			-0.013		dB/°C
Input P1dB			+11		dBm
Single-Side Band Noise Figure			13.5		dB
IIP3	Two Tones, $\Delta f_{IF} = 5MHz$, $P_{IF} = -7dBm/Tone$		+25.8		dBm
IIP2 (Note 6)	Two Tones, $\Delta f_{IF} = 5MHz$, $P_{IF} = -7dBm/Tone$, $f_{LO} + f_{IF1} + f_{IF2}$		+50		dBm
LO-RF Leakage			-36		dBm
LO-IF Leakage			-60		dBm

Note 1: Absolute Maximum Ratings are those values beyond which the life of a device may be impaired.

Note 2: Specifications over the $-40^\circ C$ to $85^\circ C$ temperature range are assured by design, characterization and correlation with statistical process controls.

Note 3: Interval from the rising edge of the Enable input to the time when the RF output is within 1dB of its steady-state output.

Note 4: Interval from the falling edge of the Enable signal to a 20dB drop in the RF output power.

Note 5: $R1 = R7 = 22.6\Omega$, $Z1 = Z7 = 100nH$.

Note 6: Second harmonic distortion measured at $f_{LO} + f_{IF1} + f_{IF2}$.

TYPICAL DC PERFORMANCE CHARACTERISTICS Test circuit shown in Figure 1.

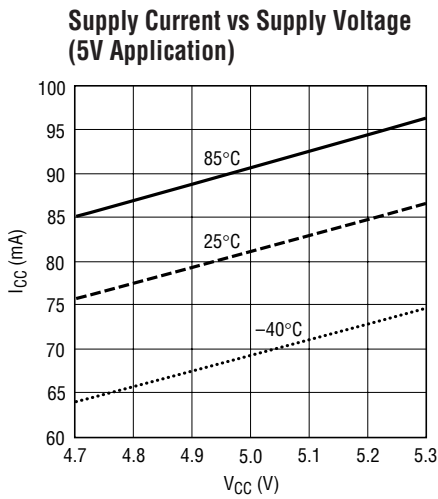

5521 G01

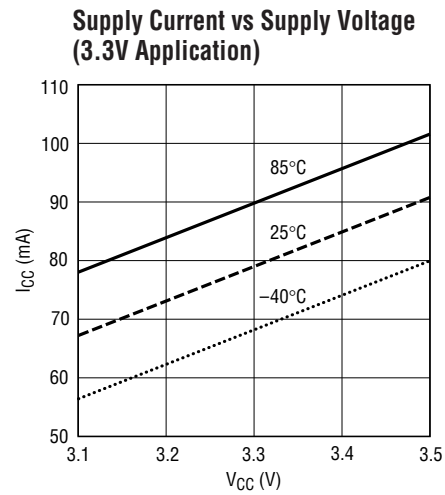

5521 G02

TYPICAL AC PERFORMANCE CHARACTERISTICS

f_{LO} = 1700MHz, f_{IF} = 250MHz, f_{RF} = 1950MHz, P_{LO} = -5dBm, V_{CC} = 5V, EN = 2.9V, T_A = 25°C, unless otherwise noted. Test circuit shown in Figure 1 is tuned for 1.95GHz output frequency and V_{CC} = 5V.

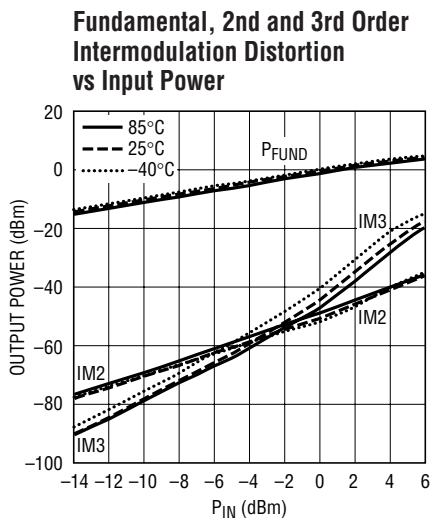

5521 G03

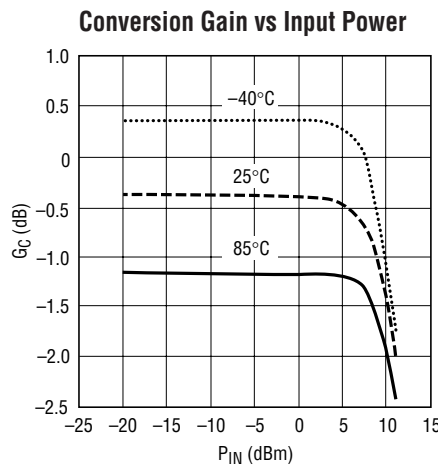

5521 G04

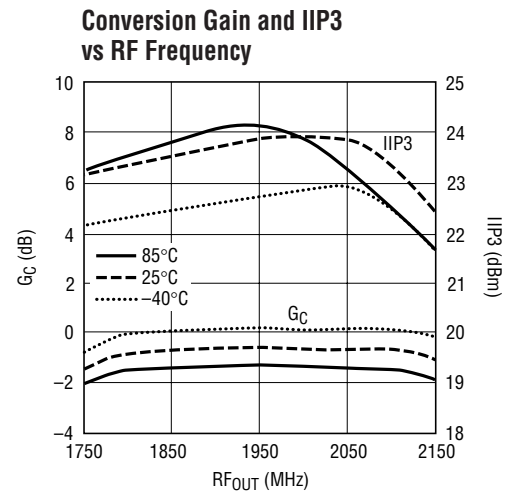

5521 G05

TYPICAL AC PERFORMANCE CHARACTERISTICS $f_{LO} = 1700\text{MHz}$, $f_{IF} = 250\text{MHz}$, $f_{RF} = 1950\text{MHz}$, $P_{LO} = -5\text{dBm}$, $V_{CC} = 5\text{V}$, $V_{EN} = 2.9\text{V}$, $T_A = 25^\circ\text{C}$, unless otherwise noted. Test circuit shown in Figure 1 is tuned for 1.95GHz output frequency and $V_{CC} = 5\text{V}$.

LO-RF Leakage vs LO Frequency

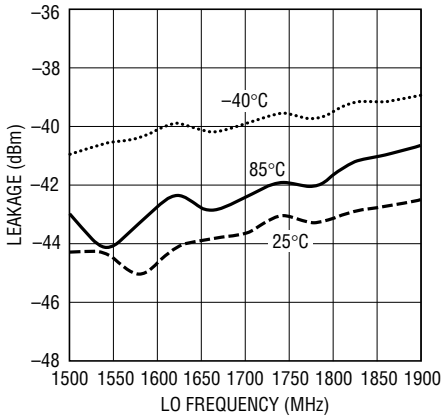

5521 G06

Conversion Gain, IIP3 and Noise Figure vs Supply Voltage

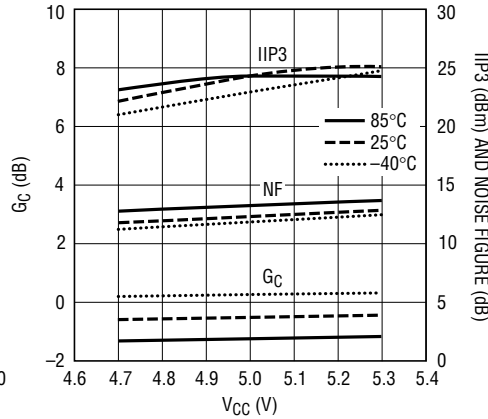

5521 G07

Conversion Gain and IIP3 vs LO Power

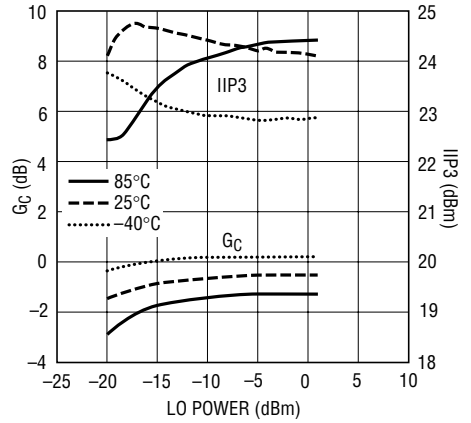

5521 G08

LO-RF Leakage vs LO Power

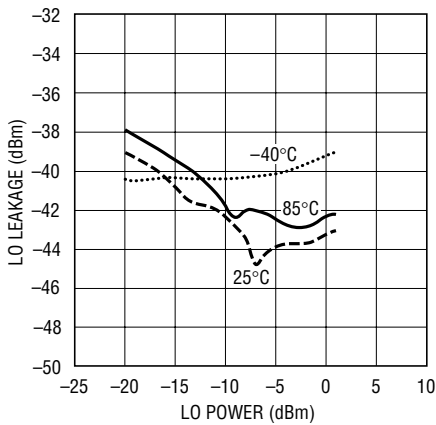

5521 G09

LO-RF Leakage vs Supply Voltage

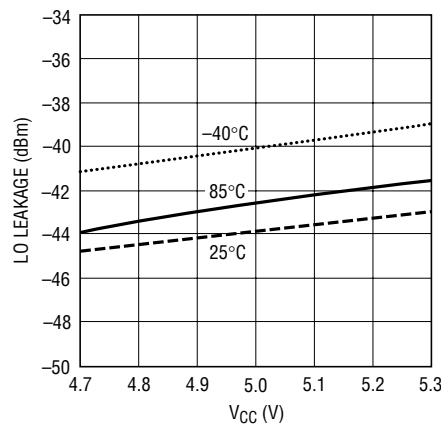

5521 G10

Noise Figure vs LO Power

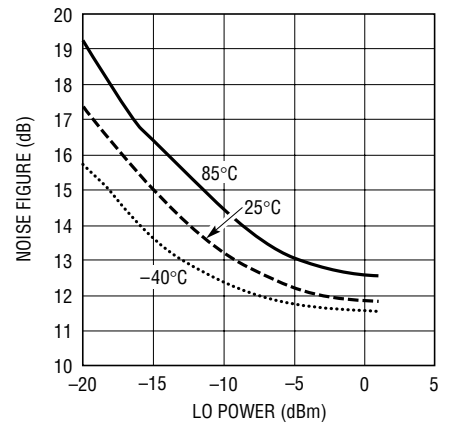

5521 G11

Low Side LO (LS) and High Side LO (HS) Comparison: Conversion Gain and IIP3 vs RF Frequency

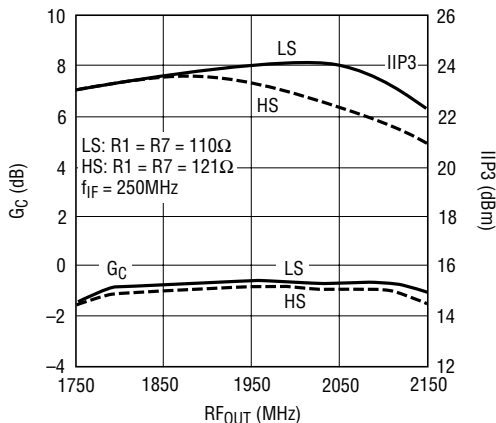

5521 G13

Low Side LO (LS) and High Side LO (HS) Comparison: Noise Figure vs RF Frequency

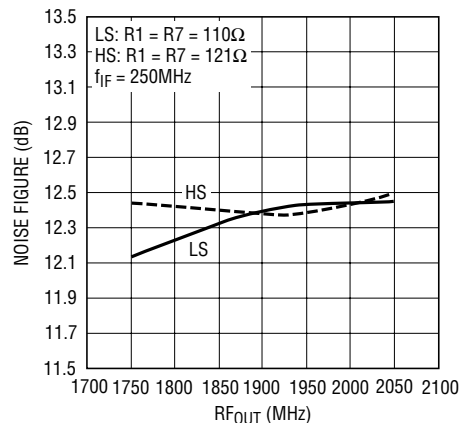

5521 G14

TYPICAL AC PERFORMANCE CHARACTERISTICS $f_{LO} = 1001\text{MHz}$, $f_{IF} = 44\text{MHz}$, $f_{RF} = 1045\text{MHz}$, $P_{LO} = -5\text{dBm}$, $V_{CC} = 5\text{V}$, $EN = 2.9\text{V}$, $T_A = 25^\circ\text{C}$, unless otherwise noted. Test circuit shown in Figure 1 is tuned for 1.045GHz output frequency.

Fundamental, 2nd and 3rd Order Intermodulation Distortion vs Input Power

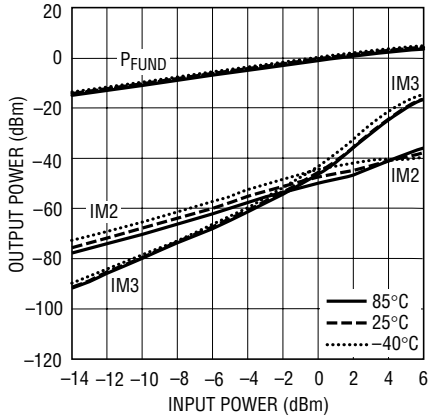

5521 G15

Conversion Gain vs Input Power

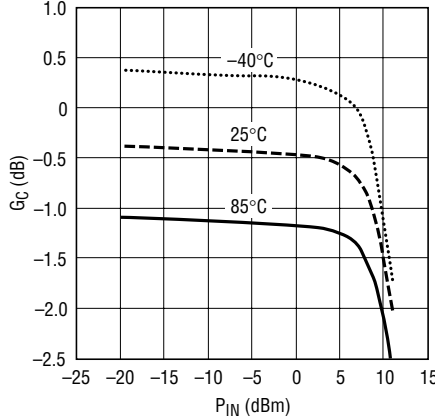

5521 G16

Conversion Gain and IIP3 vs RF Frequency, Fixed IF

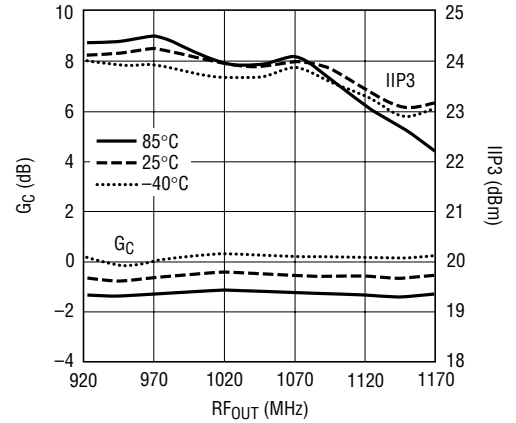

5521 G17

LO-RF Leakage vs LO Frequency

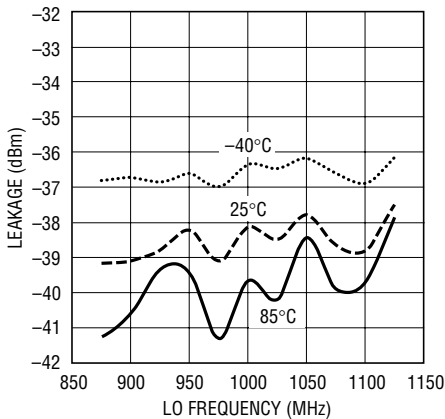

5521 G18

Conversion Gain, IIP3 and Noise Figure vs Supply Voltage

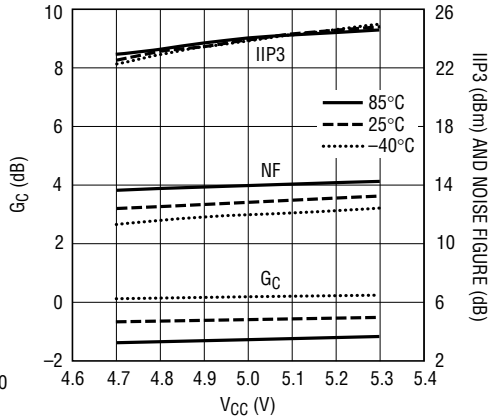

5521 G19

Conversion Gain and IIP3 vs LO Power

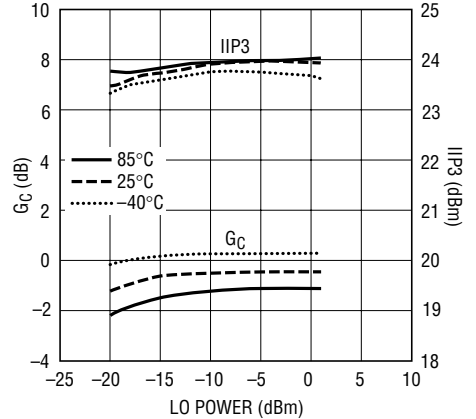

5521 G20

LO-RF Leakage vs LO Power

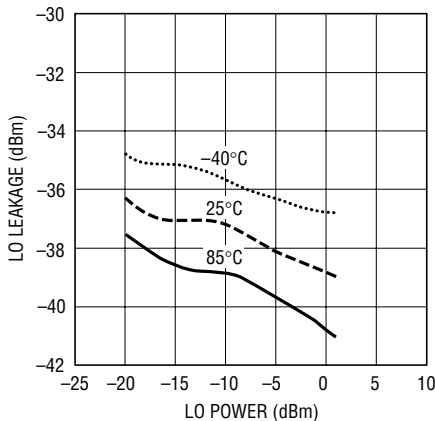

5521 G21

LO-RF Leakage vs Supply Voltage

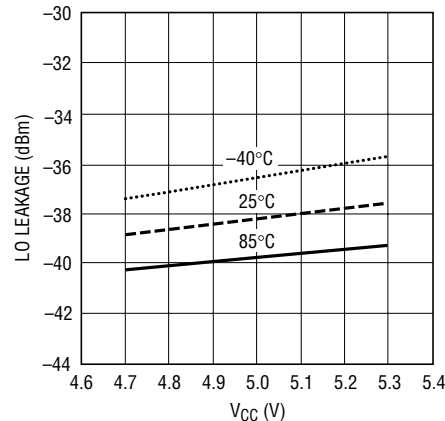

5521 G22

TYPICAL AC PERFORMANCE CHARACTERISTICS $f_{LO} = 1001\text{MHz}$, $f_{IF} = 44\text{MHz}$, $f_{RF} = 1045\text{MHz}$, $P_{LO} = -5\text{dBm}$, $V_{CC} = 5\text{V}$, $V_{EN} = 2.9\text{V}$, $T_A = 25^\circ\text{C}$, unless otherwise noted. Test circuit shown in Figure 1 is tuned for 1.045GHz output frequency.

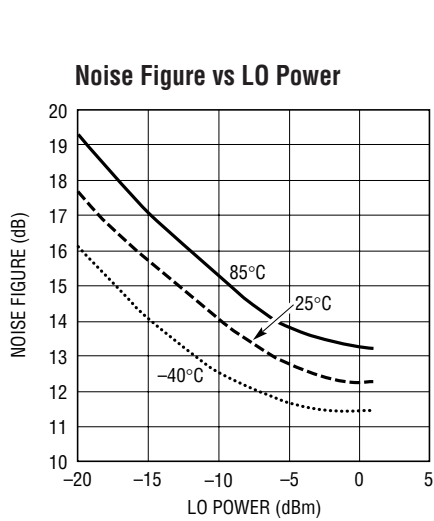

5521 G23

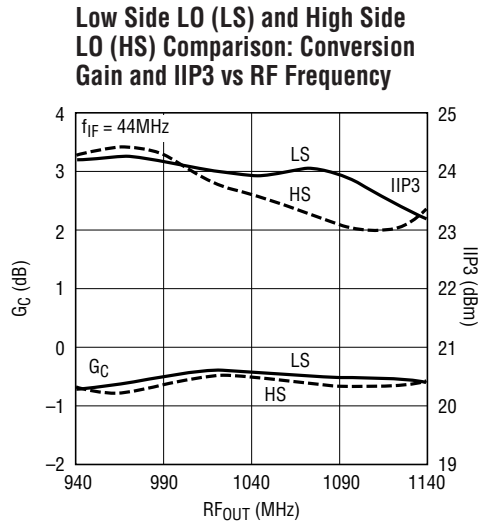

5521 G34

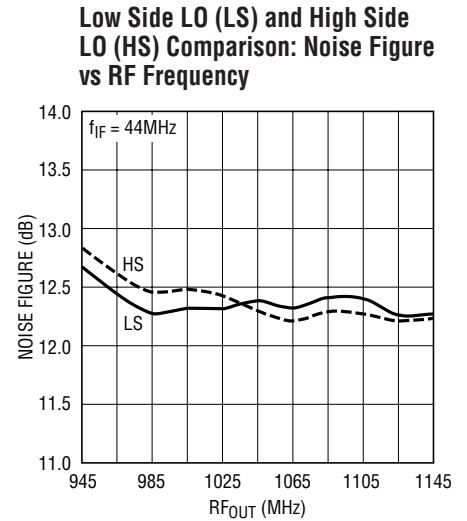

5521 G24

$f_{LO} = 1.7\text{GHz}$, $f_{IF} = 250\text{MHz}$, $f_{RF} = 1.95\text{GHz}$, $P_{LO} = -5\text{dBm}$, $V_{CC} = 3.3\text{V}$, $V_{EN} = 2.9\text{V}$, $T_A = 25^\circ\text{C}$, unless otherwise noted. Test circuit shown in Figure 1 is tuned for 1.95GHz output frequency and $V_{CC} = 3.3\text{V}$.

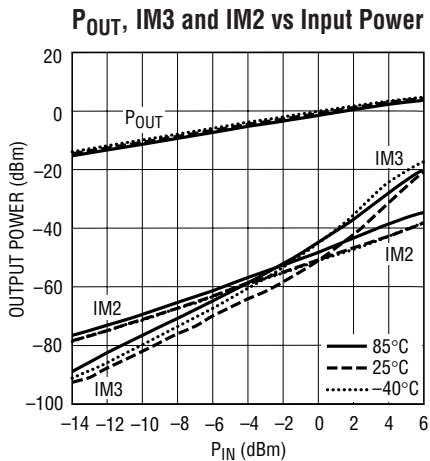

5521 G25

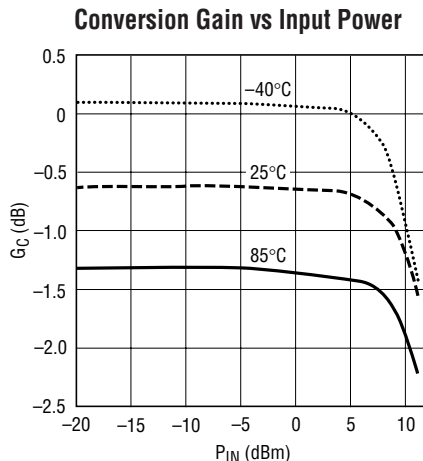

5521 G26

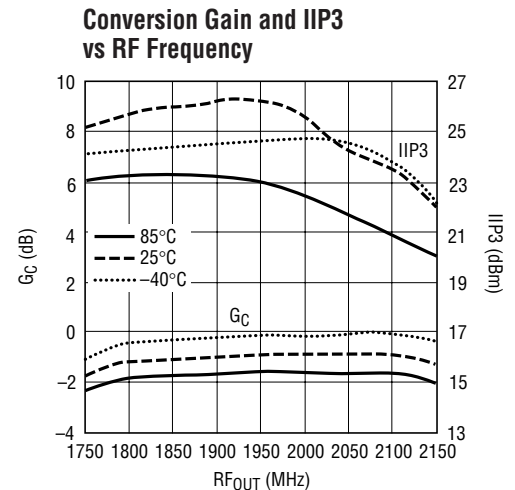

5521 G27

TYPICAL AC PERFORMANCE CHARACTERISTICS $f_{LO} = 1.7\text{GHz}$, $f_{IF} = 250\text{MHz}$, $f_{RF} = 1.95\text{GHz}$, $P_{LO} = -5\text{dBm}$, $V_{CC} = 3.3\text{V}$, $V_{EN} = 2.9\text{V}$, $T_A = 25^\circ\text{C}$, unless otherwise noted. Test circuit shown in Figure 1 is tuned for 1.95GHz output frequency and $V_{CC} = 3.3\text{V}$.

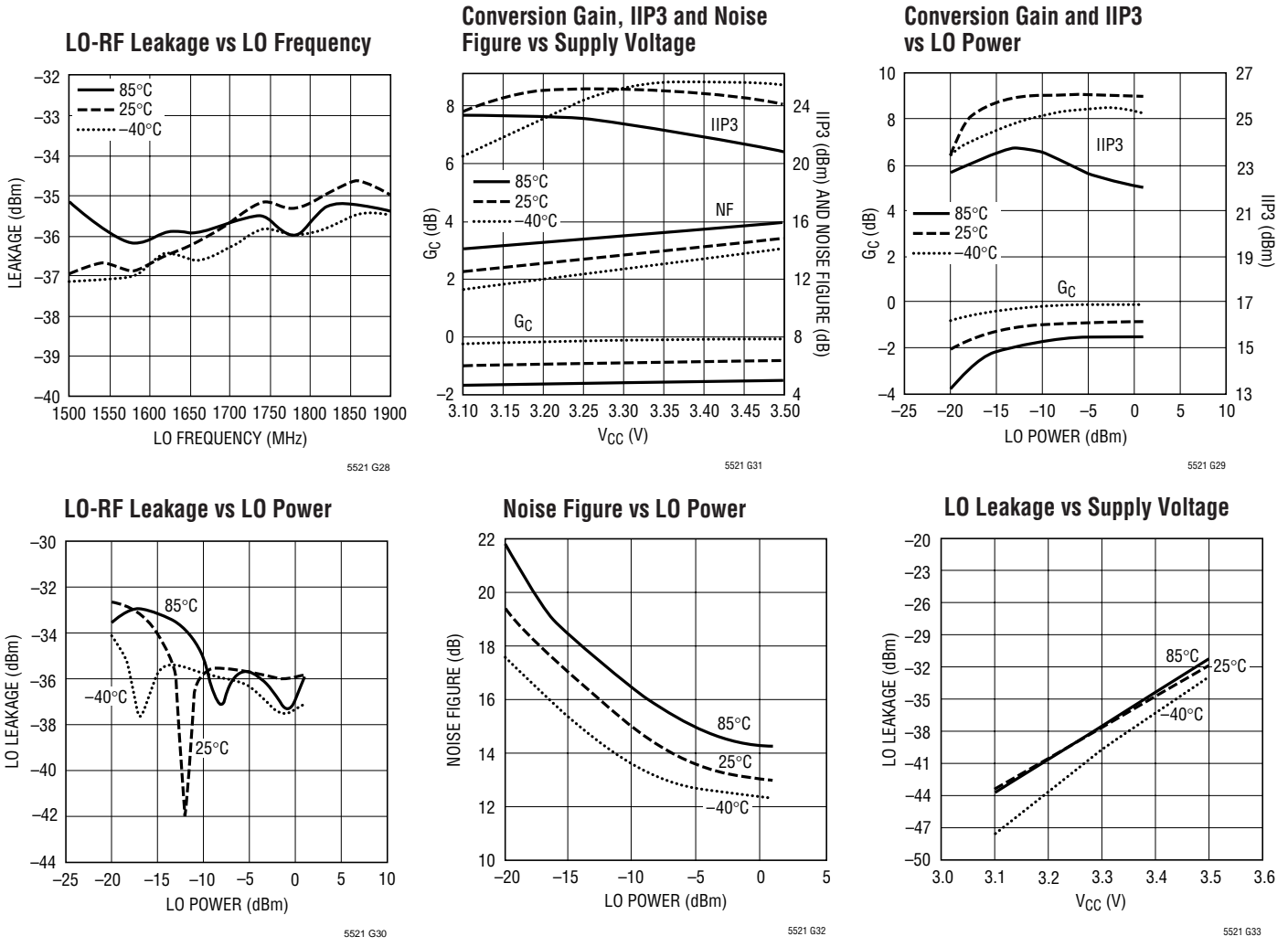

PIN FUNCTIONS

GND (Pins 1, 4, 10, 11, 13, 14, 16): Ground. These pins are internally connected to the Exposed Pad for improved isolation. They should be connected to RF ground on the printed circuit board, and are not intended to replace the primary grounding through the backside of the package.

IN⁺, IN⁻ (Pins 2, 3): Differential Input Pins. Each pin requires a resistive DC path to ground. See Applications Information for choosing the resistor value. External matching is required.

EN (Pin 5): Enable Input Pin. The enable voltage should be at least 2.9V to turn the chip on and less than 0.2V to turn the chip off.

V_{CC} (Pins 6, 7, 8): Power Supply Pins. Total current draw for these three pins is 40mA.

OUT⁺, OUT⁻ (Pins 12, 9): RF Output Pins. These pins must have a DC connection to the supply voltage (see Applications Information). These pins draw 20mA each. External matching is required.

LO (Pin 15): Local Oscillator Input. This input is internally DC biased to 0.96V. Input signal must be AC coupled.

Exposed Pad (Pin 17): Circuit Ground Return for the Entire IC. For best performance, this pin must be soldered to the printed circuit board.

BLOCK DIAGRAM

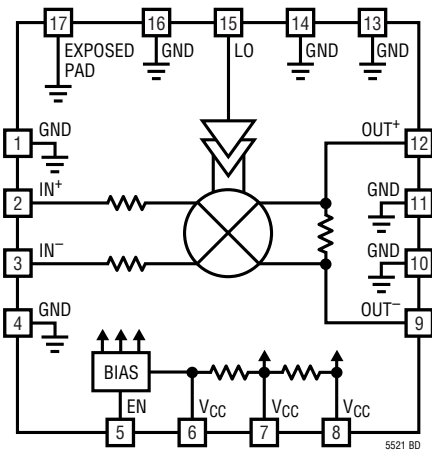

TEST CIRCUITS

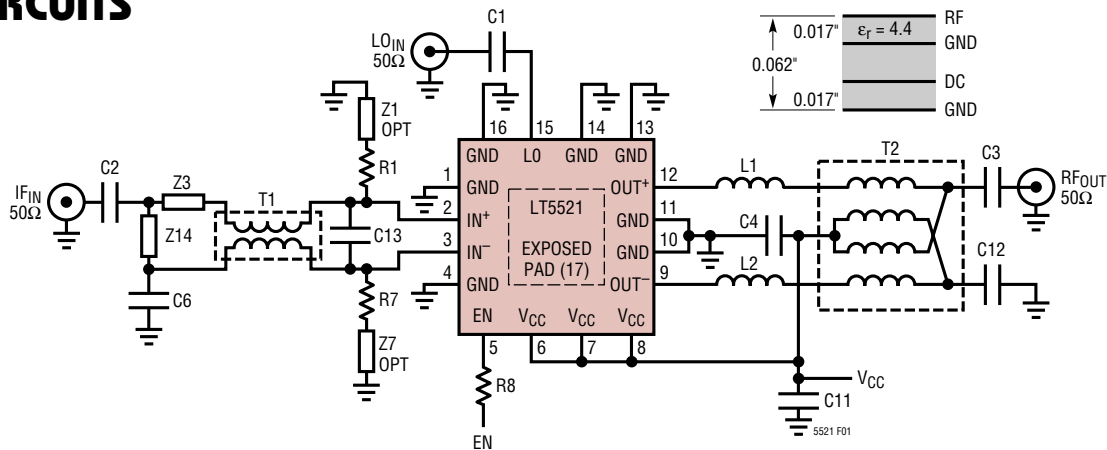

Figure 1. Demonstration Board Schematic

Table 1. Demonstration Board Bill of Materials^{1, 2}

REF	$f_{IF} = 250\text{MHz}$, $f_{RF} = 1.95\text{GHz}$ $f_{LO} = 1.7\text{GHz}$, $V_{CC} = 5\text{V}$	$f_{IF} = 44\text{MHz}$, $f_{RF} = 1.045\text{GHz}$ $f_{LO} = 1.001\text{GHz}$, $V_{CC} = 5\text{V}$	$f_{IF} = 250\text{MHz}$, $f_{RF} = 1.95\text{GHz}$ $f_{LO} = 1.7\text{GHz}$, $V_{CC} = 3.3\text{V}$
R1, R7	110Ω, 1%	110Ω, 1%	22.6Ω, 1%
Z14	10pF	120nH	10pF
Z3	0Ω	150pF	0Ω
L1, L2	2.7nH	10nH	2.7nH
T1	M/A-COM MABACT0010 ³	M/A-COM MABACT0010 ³	M/A-COM MABACT0010 ³
T2	M/A-COM ETC1.6-4-2-3	M/A-COM ETC1.6-4-2-3	M/A-COM ETC1.6-4-2-3
C1, C13	6.8pF	27pF	6.8pF
C3	82pF	3.9pF	82pF
C12	82pF	1nF	82pF
C2, C4, C6	1nF	1nF	1nF
C11	1μF	1μF	1μF
Z1, Z7	0Ω	0Ω	100nH
THIS COMPONENT CAN BE REPLACED BY PCB TRACE ON FINAL APPLICATION			
R8	10k	10k	10k

Note 1: Tabulated values are used for characterization measurements.

Note 2: Components shown on the schematic are included for consistency with the demo board. If no value is shown for the component, the site is unpopulated.

Note 3: T1 also M/A-COM ETC1-1-13 and Sprague Goodman GLSW4M202. These alternative transformers have been measured and have similar performance.

APPLICATIONS INFORMATION

The LT5521 is a high linearity double-balanced active mixer. The chip consists of a double-balanced mixer core, a high performance LO buffer and associated bias and enable circuitry. The chip is designed to operate with a supply voltage ranging from 3.15V to 5.25V.

Table 2. Port Impedance

FREQUENCY (MHz)	DIFFERENTIAL INPUT	DIFFERENTIAL OUTPUT	SINGLE-ENDED LO
50	19.8 + j0.7	282.2 – j8.4	49.9 + j0.1
100	20.1 + j2.0	282.3 – j20.8	49.8 + j0.3
300	18.2 + j5.3	262.3 – j55.1	49.2 + j0.9
600	15.2 + j16.8	231.4 – j67.0	47.7 + j2.0
1000	14.5 + j28.1	215.0 – j124.5	45.3 + j2.8
1500	20.5 + j42.3	109.5 – j158.0	43.3 + j2.8
2000	48.2 + j26.8	52.9 – j92.1	43.0 + j3.3
2300	18.2 + j29.4	61.6 – j74.2	43.4 + j4.6
3200	22.4 + j125.1	14.2 – j27.5	44.6 + j14.0
3500		27.9 – j4.4	42.4 + j17.9
4000		42.8 – j16.0	38.6 + j22.8

Signal Input Interface

Figure 2 shows the signal inputs of the LT5521. The signal input pins are connected to the common emitter nodes of the mixer quad differential pairs. The real part of the differential IN⁺/IN⁻ impedance is 20Ω. The mixer core current is set by external resistors R1 and R7. Setting their values at 110Ω, the nominal DC voltage at the inputs is 2.2V with V_{CC} = 5V. Figure 3 shows the input return loss for a matched input at 250MHz.

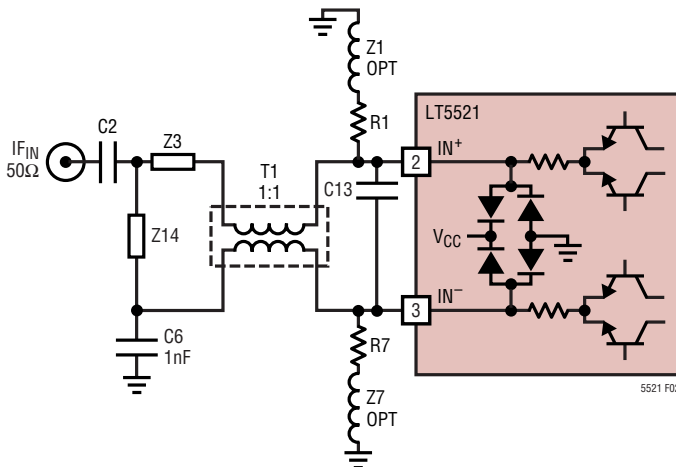

Figure 2. Signal Input with External Matching

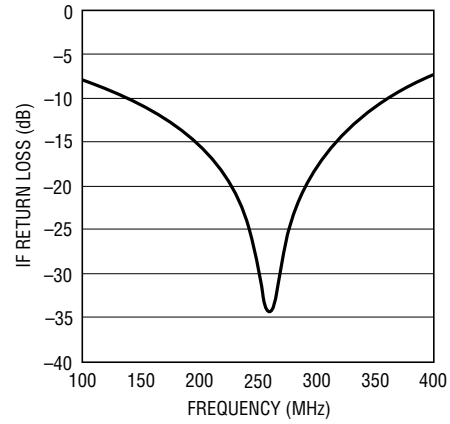

Figure 3. IF Input Return Loss

For input frequencies above 100MHz, a broadband impedance matching transformer with a 1:1 impedance ratio is recommended. Table 3 provides the component values necessary to match various IF frequencies using the M/A-COM CT0010 transformer (T1, Figure 1).

Table 3. Component Values for Input Matching Using the M/A-COM CT0010

IF	C2	Z14	Z3
44MHz	1000pF	120nH	150pF
95MHz	820pF	33pF	27nH
120MHz	1000pF	27pF	18nH
150MHz	330pF	22pF	10nH
170MHz	330pF	18pF	6.8nH
250MHz	82pF	10pF	0Ω
300MHz	15pF	3.9pF	0Ω
435MHz	8.2pF	0.5pF	0Ω
520MHz	6.8pF	Unused	0Ω

Below 100MHz, the Mini-Circuits TCM2-1T or the Pulse CX2045 are better choices for a wider input match. This configuration is shown in Figure 4. The series 1nF capacitors maintain differential symmetry while providing DC isolation between the inputs. This helps to improve LO suppression.

Shunt capacitor C13 (Figure 2) is an optional capacitor across the input pins that significantly improves LO suppression. Although this capacitor is optional, it is important to regulate LO suppression, mitigating part-to-part variation. This capacitor should be optimized depending

APPLICATIONS INFORMATION

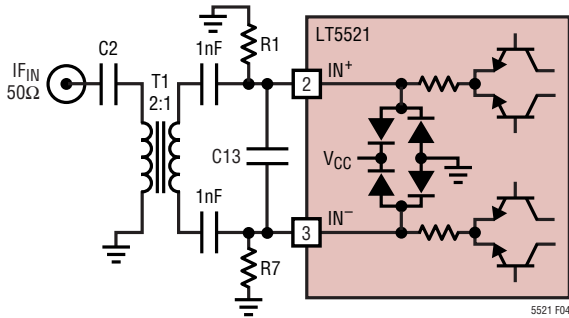

Figure 4. Low Frequency Signal Input

on the IF input frequency and the LO frequency. Smaller C13 values have reduced impact on the LO output suppression; larger values will degrade the conversion gain.

A single-ended 50Ω source can also be matched to the differential signal inputs of the LT5521 without an input transformer. Figure 5 shows an example topology for a discrete balun, and Table 4 lists component values for several frequencies. The discrete input match is intrinsically narrowband. LO suppression to the output is degraded and noise figure degrades by 4dB for input frequencies greater than 200MHz. Noise figure degradation is worse at lower input frequencies.

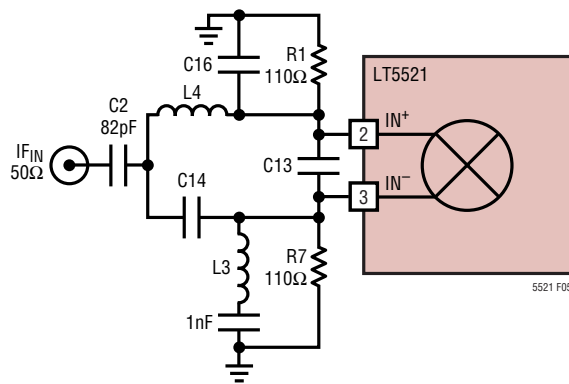

Figure 5. Alternative Transformerless Input Circuit Using Low Cost Discrete Components

Table 4. Component Values for Discrete Bridge Balun Signal Input Matching

IF (MHz)	C14, C16 (pF)	L3, L4 (nH)
220	22	22
250	18	18
640	4.7	4.7

Operation at Reduced Supply Voltage

External resistors R1 and R7 (Figure 2) set the current through the mixer core. For best distortion performance, these resistors should be chosen to maintain a total of 40mA through the mixer core (20mA per side). At 5V supply, R1 and R7 should be 110Ω. Table 5 shows recommended values for R1 and R7 at various supply voltages. **Caution: Using values below the recommended resistance can adversely affect operation or damage the part.**

Table 5. Minimum External Resistor Values vs Supply Voltage

V _{CC} (V)	R1, R7 (Ω)
5	110
4.5	82.5
4	54.9
3.5	38.3
3.3	23.2

Excessive mismatch between the external resistors R1 and R7 will degrade performance, particularly LO suppression. Resistors with 1% mismatch are recommended for optimum performance.

Figure 2 shows RF chokes in series with R1 and R7. These inductors are optional. In general, the chokes improve the conversion gain and noise figure by 2dB at 3.3V (i.e., at the minimum values of R1 and R7). The DC resistance variation of the RF chokes must be considered in the 1% source resistance mismatch suggested for maintaining LO suppression performance.

Figure 6 indicates the typical performance of the LT5521 as the external source resistance (R1, R7) is varied while keeping the supply current constant. Figure 6 data was taken without the benefit of input chokes, and shows the gradual gain degradation for smaller values of the input resistors R1 and R7. Figure 7 shows the typical behavior when the supply voltage is fixed and the core current is varied by adjusting values of the external resistors R1 and R7. Decreasing the core current decreases the power consumption and improves noise figure but degrades distortion performance. Figure 8 demonstrates the impact of the RF chokes in series with the source resistance at 3.3V. There is a 2dB improvement in conversion gain and noise figure and a corresponding decrease in IIP3.

APPLICATIONS INFORMATION

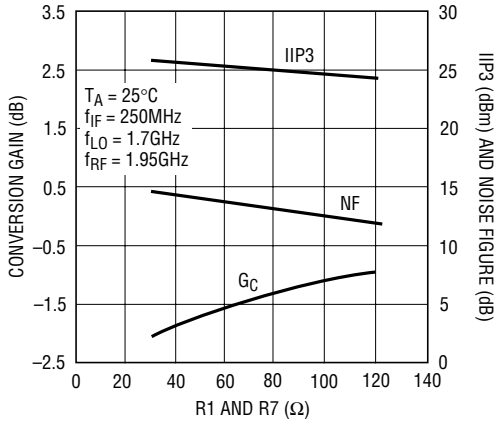

Figure 6. IIP3, G_C and Noise Figure vs External Resistance, Constant Core Current (Variable Supply Voltage)

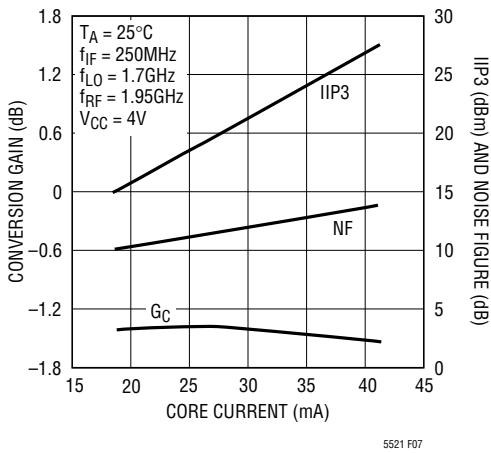

Figure 7. IIP3, G_C and Noise Figure vs Core Current, Constant Supply Voltage

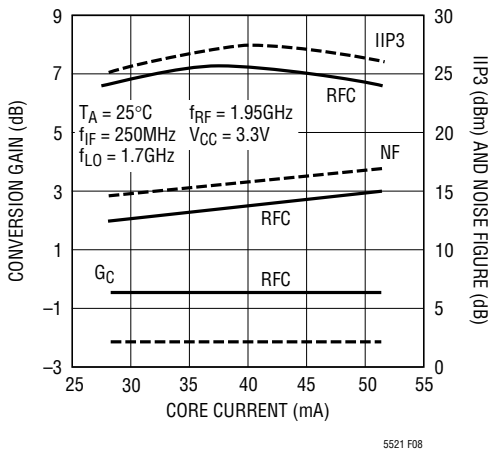

Figure 8. Comparison of 3.3V Performance With and Without Input RF Choke

The user can tailor the biasing of the LT5521 to meet individual system requirements. It is recommended to choose a source resistance as large as possible to minimize sensitivity to power supply variation.

Output Interface

A DC connection to V_{CC} must be provided on the PCB to the output pins. These pins will draw approximately 20mA each from the power supply. On-chip, there is a nominal 300Ω differential resistance between the output pins. Figure 9 shows a typical matching circuit using an external balun to provide differential to single-ended conversion.

LO suppression and 2xLO suppression are influenced by the symmetry of the external output matching circuitry. PCB design must maintain the trace layout symmetry of the output pins as much as possible to minimize these signals.

The M/A-COM ETC1.6-4-2-3 4:1 transformer (T2, Figure 9) is suitable for applications with output frequencies between 500MHz and 2700MHz. Output matching at various frequencies is achieved by adding inductors in series with the output (L1, L2) and DC blocking capacitor C3, as shown in Figure 9. Table 6 specifies center frequency and bandwidth of the output match for different matching configurations. Figure 10 shows the typical output return loss vs frequency for 1GHz and 2GHz applications. Capacitor C12 provides a solid AC ground at the RF output frequency.

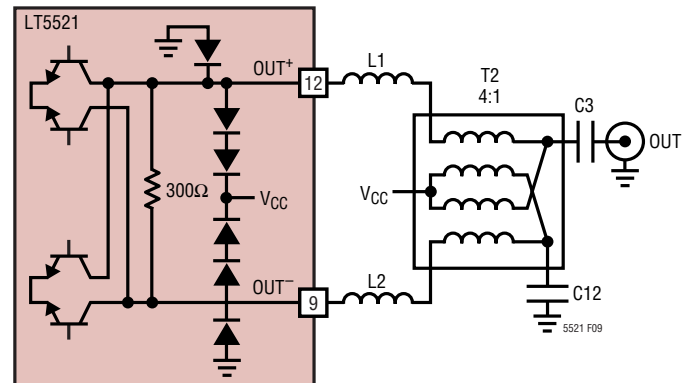

Figure 9. Simplified Output Circuit with External Matching Components

APPLICATIONS INFORMATION

Table 6. Matching Values Using M/A-COM ETC1.6-4-2-3 Output Transformer

f _{OUT}	L1, L2	C3	C12	Δf (10dB RL)
2.4GHz	0nH	82pF	82pF	450MHz
2.2GHz	1nH	82pF	82pF	430MHz
2.0GHz	2.7nH	82pF	82pF	400MHz
1.7GHz	4.7nH	82pF	82pF	400MHz
1.3GHz	10nH	82pF	82pF	400MHz
1.0GHz	10nH	3.9pF	1nF	500MHz

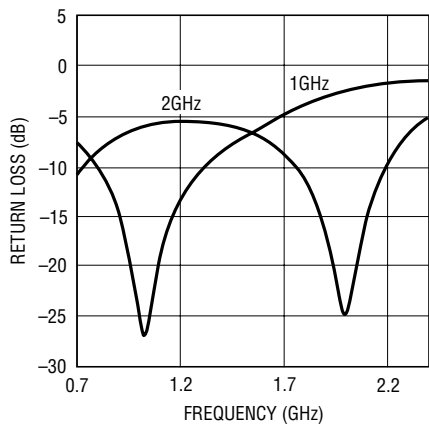

Figure 10. Output Return Loss vs Frequency

For applications with LO and output frequencies below 1GHz, the M/A-COM MABAES0054 is recommended for the output component T2. This transformer maintains better low frequency output symmetry. Table 7 lists components necessary for a 750MHz output match using the M/A-COM MABAES0054.

Table 7. Matching Values Using M/A-COM MABAES0054 Output Transformer

f _{OUT}	L1, L2	C3	C12	Δf (10dB RL)
750MHz	33nH	82pF	1nF	500MHz

Hybrid baluns provide a low cost alternative for differential to single-ended conversion. The critical performance parameters of conversion gain, IIP3, noise figure and LO suppression are largely unaffected by these transformers. However, their limited bandwidth and reduced symmetry outside the frequency of operation degrades the suppression of higher order LO harmonics, particularly 2xLO. Murata LBD21 series hybrid balun transformers, for example, can be used for output frequencies as low as 840MHz and as high as 2.4GHz.

Johanson Technology supplies the 3700BL15B100S hybrid balun for use between 3.4GHz and 4GHz. With additional matching, this transformer can be used for applications between 3.3GHz and 3.7GHz. Example LT5521 performance is shown in Figure 11.

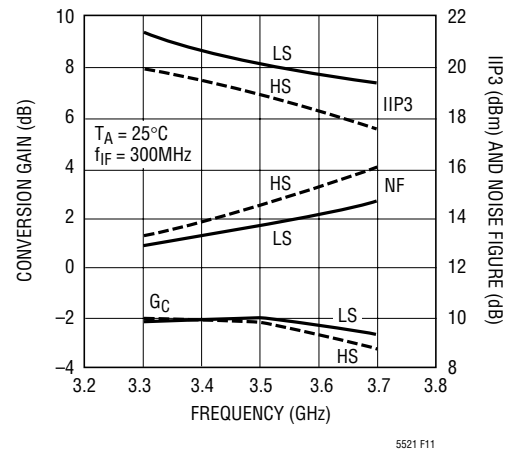

Figure 11. LT5521 Performance for an Application Tuned to 3.5GHz with Low Side (LS) and High Side (HS) LO Injection

LO Interface

The LO input pin is internally matched to 50Ω. It has an internal DC bias of 960mV. External AC coupling is required. Figure 12 shows a simplified schematic of the LO input. Overdriving the LO input will dramatically reduce the performance of the mixer. The LO input power should not exceed +1dBm for normal operation. Select C1 (Figure 12) only large enough to achieve the desired LO input return loss. This reduces external low frequency signal amplification through the LO buffer.

For applications with LO frequency in the range of 2.1GHz to 2.4GHz, the LT5521 achieves improved distortion and

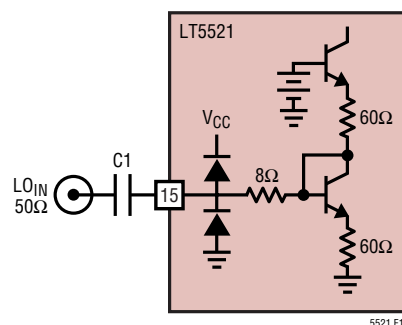

Figure 12. Simplified LO Input Circuit

APPLICATIONS INFORMATION

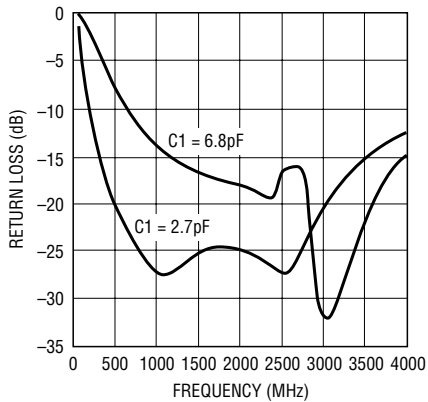

Figure 13. LO Port Return Loss

noise performance with slightly reduced current through the mixer core. Accordingly, in a 5V application operating within this LO frequency range, the recommended source resistor value (R1 and R7) is increased to 121Ω.

Enable Interface

Figure 14 shows a simplified schematic of the EN pin interface. The voltage necessary to turn on the LT5521 is 2.9V. To disable the chip, the enable voltage must be below 0.2V. If the EN pin is not connected, the chip is disabled. It is not recommended, however, that any pins be left floating for normal operation.

It is important that the voltage at the EN pin never exceed V_{CC} , the power supply voltage, by more than 0.2V. If this should occur, the supply current could be sourced through the EN pin ESD protection diodes, potentially damaging the IC. The resistor R8 (Figure 1) in series with the EN pin on the demo board is populated with a 10kΩ resistor to protect the EN pin to avoid inadvertent damage to the IC. For timing measurements, this resistor is replaced with a

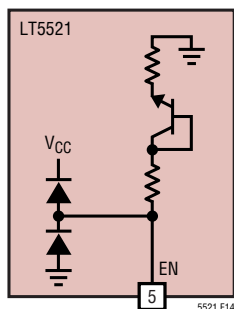

Figure 14. Enable Input Circuit

0Ω resistor. If the shutdown function is not required, then the EN pin should be wired directly to the V_{CC} power supply on the PCB.

Supply Decoupling

The power supply decoupling shown in the schematic of Figure 1 is recommended to minimize spurious signal coupling into the output through the power supply.

ACPR Performance

Because of its high linearity and low noise, the LT5521 offers outstanding ACPR performance in a variety of applications. For example, Figures 15 and 16 show ACPR and Alternate Channel measurements for single channel and 4-channel 64 DPCH W-CDMA signals at 1.95GHz output frequency.

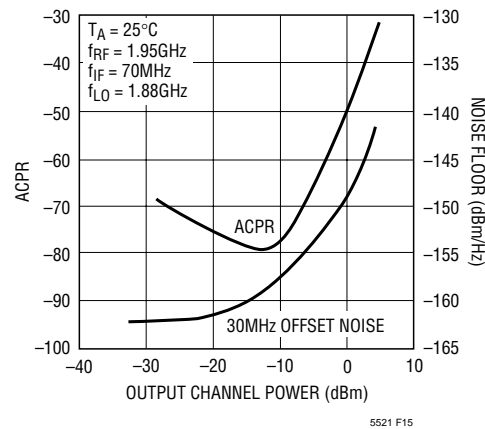

Figure 15. Single Channel W-CDMA ACPR and 30MHz Offset Noise Performance

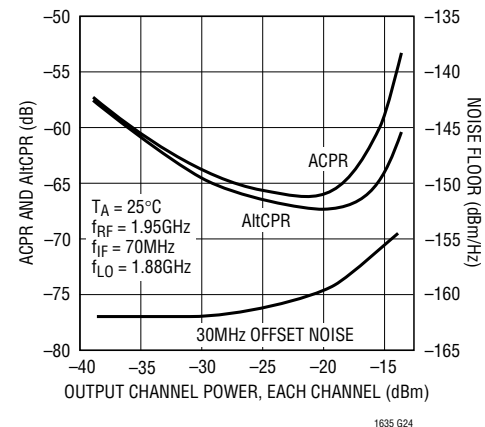

Figure 16. 4-Channel W-CDMA ACPR, AltCPR and 30MHz Offset Noise Floor

APPLICATIONS INFORMATION

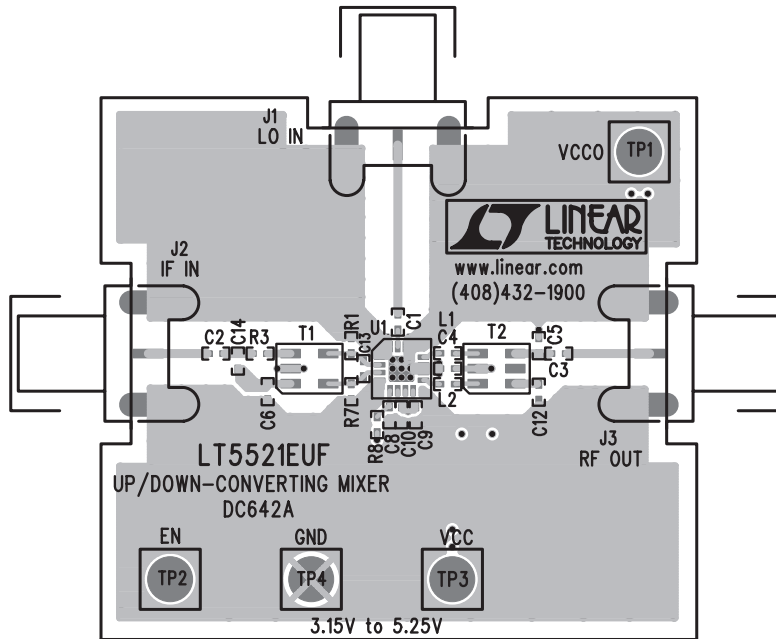
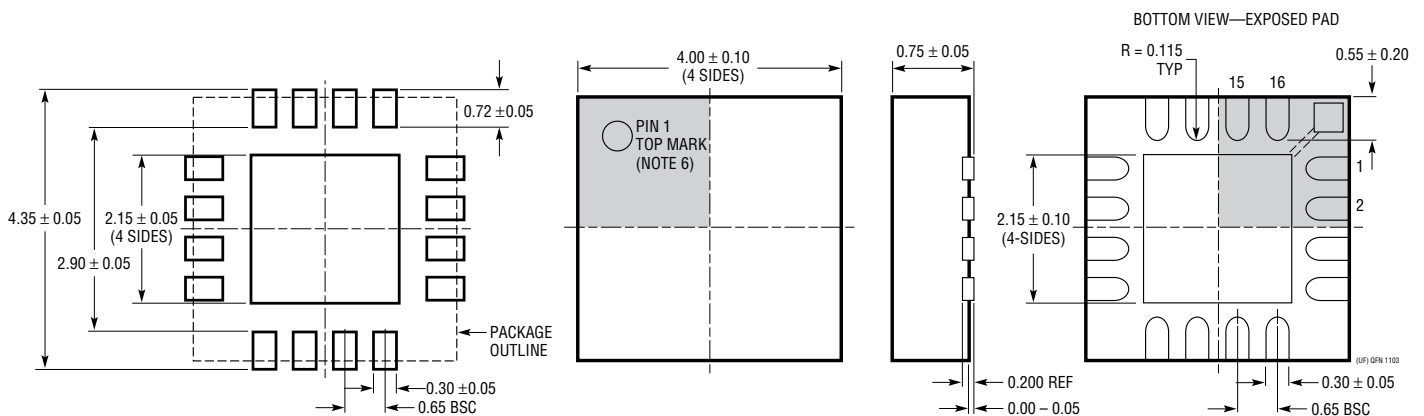

Figure 17. Top View of Demo Board

PACKAGE DESCRIPTION

UF Package
16-Lead Plastic QFN (4mm × 4mm)
 (Reference LTC DWG # 05-08-1692)



- NOTE:
1. DRAWING CONFORMS TO JEDEC PACKAGE OUTLINE MO-220 VARIATION (WGCG)
 2. DRAWING NOT TO SCALE
 3. ALL DIMENSIONS ARE IN MILLIMETERS
 4. DIMENSIONS OF EXPOSED PAD ON BOTTOM OF PACKAGE DO NOT INCLUDE MOLD FLASH. MOLD FLASH, IF PRESENT, SHALL NOT EXCEED 0.15mm ON ANY SIDE
 5. EXPOSED PAD SHALL BE SOLDER PLATED
 6. SHADED AREA IS ONLY A REFERENCE FOR PIN 1 LOCATION ON THE TOP AND BOTTOM OF PACKAGE

RELATED PARTS

PART NUMBER	DESCRIPTION	COMMENTS
Infrastructure		
LT5511	High Linearity Upconverting Mixer	RF Output to 3GHz, 17dBm IIP3, Integrated LO Buffer
LT5512	DC-3GHz High Signal Level Downconverting Mixer	DC to 3GHz, 21dBm IIP3, Integrated LO Buffer
LT5514	Ultralow Distortion, Wideband Digitally Controlled Gain Amplifier/ADC Driver	BW = 850MHz, OIP3 = 47dBm at 100MHz, 22.5dB Gain Control Range
LT5515	1.5GHz to 2.5GHz Direct Conversion Quadrature Demodulator	20dBm IIP3, Integrated LO Quadrature Generator
LT5516	0.8GHz to 1.5GHz Direct Conversion Quadrature Demodulator	21.5dBm IIP3, Integrated LO Quadrature Generator
LT5517	40MHz to 900MHz Quadrature Demodulator	21dBm IIP3, Integrated LO Quadrature Generator
LT5519	0.7GHz to 1.4GHz High Linearity Upconverting Mixer	17.1dBm IIP3 at 1GHz, Integrated RF Output Transformer with 50 Ω Matching, Single-Ended LO and RF Ports Operation
LT5520	1.3GHz to 2.3GHz High Linearity Upconverting Mixer	15.9dBm IIP3 at 1.9GHz, Integrated RF Output Transformer with 50 Ω Matching, Single-Ended LO and RF Ports Operation
LT5522	600MHz to 2.7GHz High Signal Level Downconverting Mixer	4.5V to 5.25V Supply, 25dBm IIP3 at 900MHz, NF = 12.5dB, 50 Ω Single-Ended RF and LO Ports
RF Power Detectors		
LT5504	800MHz to 2.7GHz RF Measuring Receiver	80dB Dynamic Range, Temperature Compensated, 2.7V to 5.25V Supply
LTC®5505	RF Power Detectors with >40dB Dynamic Range	300MHz to 3GHz, Temperature Compensated, 2.7V to 6V Supply
LTC5507	100kHz to 1000MHz RF Power Detector	100kHz to 1GHz, Temperature Compensated, 2.7V to 6V Supply
LTC5508	300MHz to 7GHz RF Power Detector	44dB Dynamic Range, Temperature Compensated, SC70 Package
LTC5509	300MHz to 3GHz RF Power Detector	36dB Linear Dynamic Range, Low Power Consumption, SC70 Package
LTC5530	300MHz to 7GHz Precision RF Power Detector	Precision V _{OUT} Offset Control, Shutdown, Adjustable Gain
LTC5531	300MHz to 7GHz Precision RF Power Detector	Precision V _{OUT} Offset Control, Shutdown, Adjustable Offset
LTC5532	300MHz to 7GHz Precision RF Power Detector	Precision V _{OUT} Offset Control, Adjustable Gain and Offset
LT5534	50MHz to 3GHz RF Power Detector	60dB Dynamic Range, Temperature Compensated, SC70 Package
Low Voltage RF Building Blocks		
LT5500	1.8GHz to 2.7GHz Receiver Front End	1.8V to 5.25V Supply, Dual-Gain LNA, Mixer, LO Buffer
LT5502	400MHz Quadrature IF Demodulator with RSSI	1.8V to 5.25V Supply, 70MHz to 400MHz IF, 84dB Limiting Gain, 90dB RSSI Range
LT5503	1.2GHz to 2.7GHz Direct IQ Modulator and Upconverting Mixer	1.8V to 5.25V Supply, Four-Step RF Power Control, 120MHz Modulation Bandwidth
LT5506	500MHz Quadrature IF Demodulator with VGA	1.8V to 5.25V Supply, 40MHz to 500MHz IF, -4dB to 57dB Linear Power Gain, 8.8MHz Baseband Bandwidth
LT5546	500MHz Quadrature IF Demodulator with VGA and 17MHz Baseband Bandwidth	17MHz Baseband Bandwidth, 40MHz to 500MHz IF, 1.8V to 5.25V Supply, -7dB to 56dB Linear Power Gain
RF Power Controllers		
LTC1757A	RF Power Controller	Multiband GSM/DCS/GPRS Mobile Phones
LTC1758	RF Power Controller	Multiband GSM/DCS/GPRS Mobile Phones
LTC1957	RF Power Controller	Multiband GSM/DCS/GPRS Mobile Phones
LTC4400	SOT-23 RF PA Controller	Multiband GSM/DCS/GPRS Phones, 45dB Dynamic Range, 450kHz Loop BW
LTC4401	SOT-23 RF PA Controller	Multiband GSM/DCS/GPRS Phones, 45dB Dynamic Range, 250kHz Loop BW
LTC4403	RF Power Controller for EDGE/TDMA	Multiband GSM/GPRS/EDGE Mobile Phones

Looking for pricing, stock, or lifecycle information?

Click below to explore more details on WIN SOURCE:

 [View LT5521EUF#PBF on WIN SOURCE](#)

 [Linear Technology](#) Information

Optimize Your Supply Chain with WIN SOURCE Solutions

-  Global Sourcing Solution
-  Obsolete Management
-  Cost Control Management
-  Shortage Management
-  Alternative Solution
-  Excess Inventory Management