



**THE DATASHEET OF
LT5511EFE#PBF**



High Signal Level Upconverting Mixer

FEATURES

- Wide RF Output Frequency Range to 3000MHz
- Broadband RF and IF Operation
- +17dBm Typical Input IP3 (at 950MHz)
- +6dBm IF Input for 1dB RF Output Compression
- Integrated LO Buffer: -10dBm Drive Level
- Single-Ended or Differential LO Input
- Double-Balanced Mixer
- Enable Function
- Single 4.0V – 5.25V Supply Voltage Range
- 16-Pin TSSOP Exposed Pad Package

APPLICATIONS

- CATV Downlink Infrastructure
- Wireless Infrastructure
- High Linearity Mixer Applications

DESCRIPTION

The LT[®]5511 mixer is designed to meet the high linearity requirements of cable TV infrastructure downstream transmitters and wireless infrastructure transmit systems. The IC includes a differential LO buffer amplifier driving a double-balanced mixer. The LO, RF and IF ports can be easily matched to a broad range of frequencies for different applications. The high performance capability of the LO buffer allows the use of a single-ended source, thus eliminating the need for an LO balun.

The LT5511 mixer delivers +17dBm typical input 3rd order intercept point at 950MHz, and +15.5dBm IIP3 at 1900MHz, with IF input signal levels of -5dBm. The input 1dB compression point is typically +6dBm.

 LT, LTC and LT are registered trademarks of Linear Technology Corporation.

TYPICAL APPLICATION

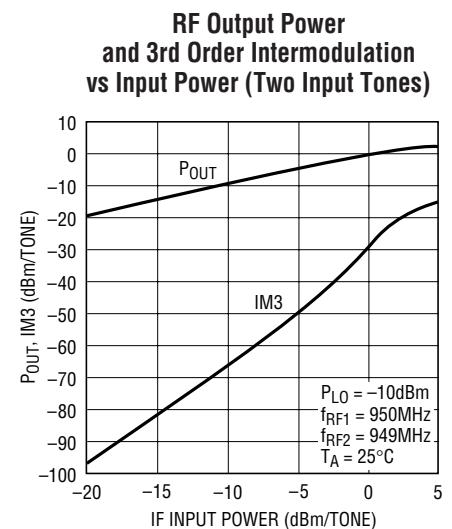
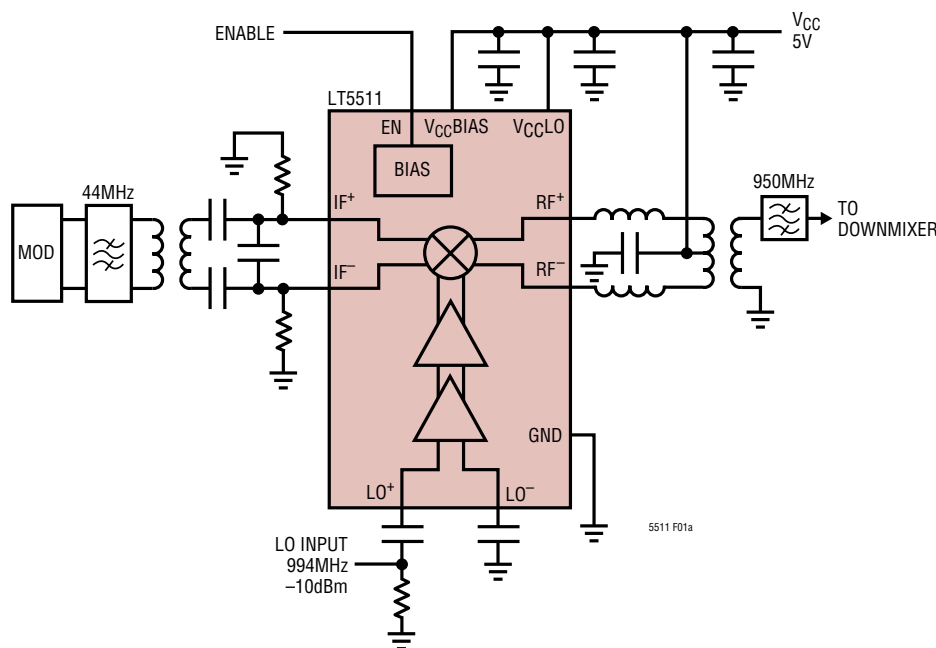

Figure 1. High Signal Level Upmixer for CATV Downlink Infrastructure.

ABSOLUTE MAXIMUM RATINGS

(Note 1)

Supply Voltage	5.5V
Enable Voltage	-0.3V to $V_{CC} + 0.3V$
LO Input Power (Differential)	10dBm
IF Input Power (Differential)	10dBm
IF ⁺ , IF ⁻ DC Currents	25mA
Operating Temperature Range	-40°C to 85°C
Storage Temperature Range	-65°C to 150°C
Lead Temperature (Soldering, 10sec).....	300°C

PACKAGE/ORDER INFORMATION

<p>TOP VIEW</p> <p>FE PACKAGE 16-LEAD PLASTIC TSSOP</p> <p>$T_{JMAX} = 150^{\circ}C$, $\theta_{JA} = 38^{\circ}C/W$ EXPOSED PAD IS GROUND (MUST BE SOLDERED TO PRINTED CIRCUIT BOARD)</p>	ORDER PART NUMBER
	LT5511EFE
	FE PART MARKING
	5511EFE

Consult LTC Marketing for parts specified with wider operating temperature ranges.

ELECTRICAL CHARACTERISTICS

PARAMETER	CONDITIONS	MIN	TYP	MAX	UNITS
$V_{CC} = 5V_{DC}$, EN = High, $T_A = 25^{\circ}C$					
IF Input Frequency Range (Note 6)			1 to 300		MHz
LO Input Frequency Range (Note 6)			30 to 2700		MHz
RF Output Frequency Range (Note 6)			10 to 3000		MHz
950MHz Application: (Test Circuit Shown in Figure 2) $V_{CC} = 5V_{DC}$, EN = High, $T_A = 25^{\circ}C$, IF Input = 50MHz at -5dBm, LO Input = 1GHz at -10dBm, RF Output Measured at 950MHz, unless otherwise noted. (Notes 2, 3)					
IF Input Return Loss	With External Matching, $Z_0 = 50\Omega$		14		dB
LO Input Power			-15 to -5		dBm
LO Input Return Loss	With External Matching, $Z_0 = 50\Omega$		14		dB
RF Output Return Loss	With External Matching, $Z_0 = 50\Omega$		17		dB
Conversion Gain			0		dB
LO to RF Leakage			-46		dBm
Input 1dB Compression			5.9		dBm
Input 3rd Order Intercept	Two-Tone, -5dBm/Tone, $\Delta f = 1MHz$		17		dBm
Input 2nd Order Intercept	Single-Tone, -5dBm		52		dBm
SSB Noise Figure			15		dB

ELECTRICAL CHARACTERISTICS

PARAMETER	CONDITIONS	MIN	TYP	MAX	UNITS
1.9GHz Application: (Test Circuit Shown in Figure 3) $V_{CC} = 5V_{DC}$, EN = High, $T_A = 25^\circ C$, IF Input = 50MHz at $-5dBm$, LO Input = 1.95GHz at $-10dBm$, RF Output Measured at 1900MHz, unless otherwise noted. (Notes 3, 4)					
IF Input Return Loss	With External Matching, $Z_0 = 50\Omega$		14		dB
LO Input Power			-15 to -5		dBm
LO Input Return Loss	With External Matching, $Z_0 = 50\Omega$		11.5		dB
RF Output Return Loss	With External Matching, $Z_0 = 50\Omega$		11.5		dB
Conversion Gain			-0.7		dB
LO to RF Leakage			-47		dBm
Input 1dB Compression			5.2		dBm
Input 3rd Order Intercept	Two-Tone, $-5dBm/Tone$, $\Delta f = 1MHz$		15.5		dBm
Input 2nd Order Intercept	Single-Tone, $-5dBm$		51		dBm
SSB Noise Figure			14		dB
Power Supply Requirements: $V_{CC} = 5V_{DC}$, EN = High, $T_A = 25^\circ C$, unless otherwise noted.					
Supply Voltage			4.0 to 5.25		V_{DC}
Supply Current			56	65	mA
Shutdown Current (Chip Disabled)	EN = Low		1	30	μA
Enable Mode Threshold	EN = High	3			V_{DC}
Disable Mode Threshold	EN = Low			0.5	V_{DC}
Turn ON Time (Note 5)			2		μs
Turn OFF Time (Note 5)			6		μs
Enable Input Current	EN = 5V		1		μA

Note 1: Absolute Maximum Ratings are those values beyond which the life of a device may be impaired.

Note 2: External components on the final test circuit are optimized for operation at $f_{RF} = 950MHz$, $f_{LO} = 1GHz$ and $f_{IF} = 50MHz$ (Figure 2).

Note 3: Specifications over the $-40^\circ C$ to $85^\circ C$ temperature range are assured by design, characterization and correlation with statistical process controls.

Note 4: External components on the final test circuit are optimized for operation at $f_{RF} = 1900MHz$, $f_{LO} = 1.95GHz$ and $f_{IF} = 50MHz$ (Figure 3).

Note 5: Turn On and Turn Off times are based on rise and fall times of RF output envelope from full power to $-40dBm$ with an IF input power of $-5dBm$.

Note 6: Part can be used over a broader range of operating frequencies. Consult factory for applications assistance.

TYPICAL PERFORMANCE CHARACTERISTICS (950MHz Application)

$V_{CC} = 5V_{DC}$, EN = High, $T_A = 25^\circ C$, IF Input = 50MHz at -5dBm, LO Input = 1GHz at -10dBm, RF Output Measured at 950MHz, unless otherwise noted. For 2-Tone Measurements: 2nd IF Input = 51MHz at -5dBm. (Test Circuit Shown in Figure 2).

RF Output Power and 3rd Order Intermodulation vs IF Input Power (Two Input Tones)

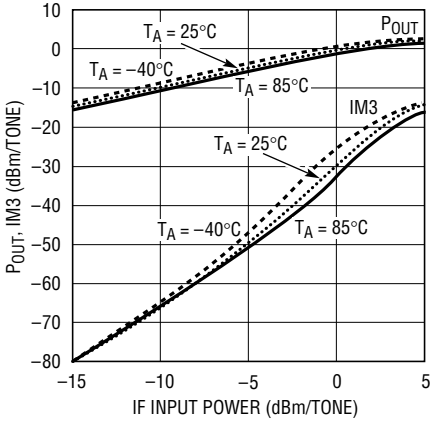

5511 G01

RF Output Power and 2nd Order Intermodulation vs IF Input Power (Single Input Tone)

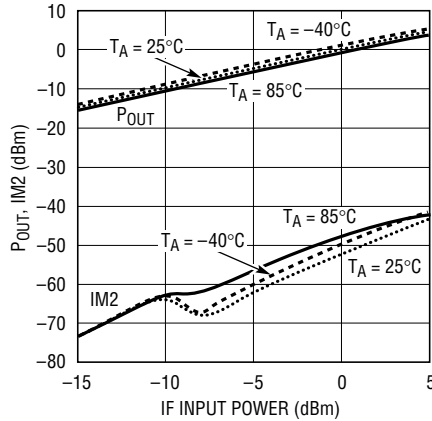

5511 G02

Conversion Gain vs IF Input Power (Single Input Tone)

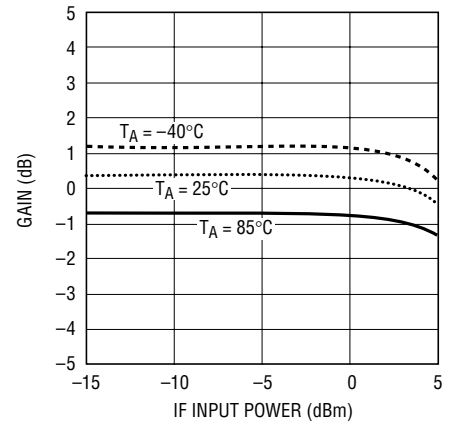

5511 G03

Conversion Gain and IIP3 vs LO Power

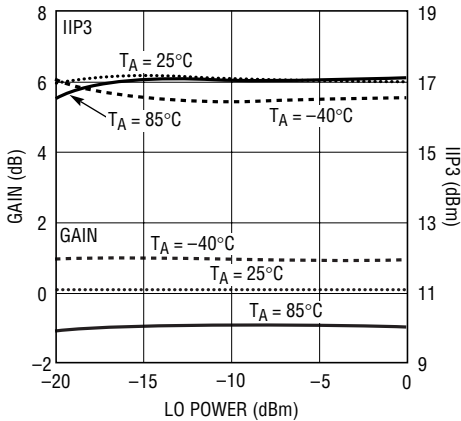

5511 G04

LO to RF Leakage vs LO Power

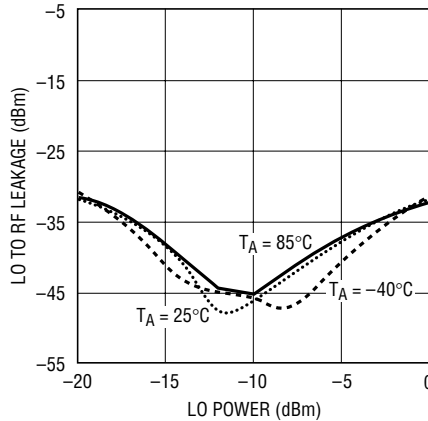

5511 G05

IIP2 vs LO Power

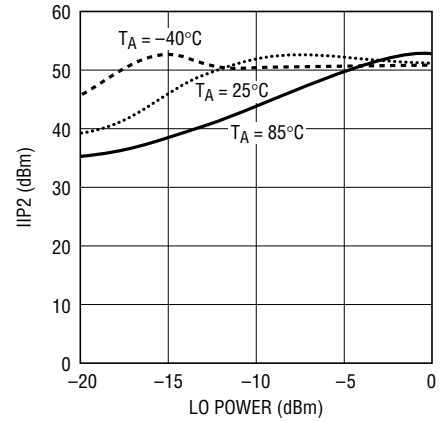

5511 G06

Conversion Gain and LO to RF Leakage vs Output Frequency

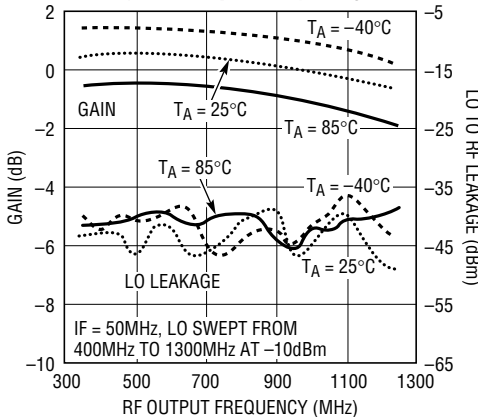

5511 G07

IIP3 and IIP2 vs Output Frequency

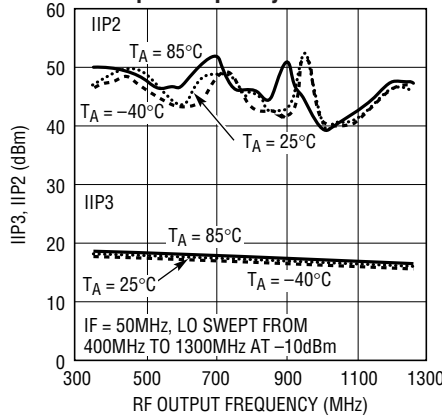

5511 G08

SSB Noise Figure vs Output Frequency

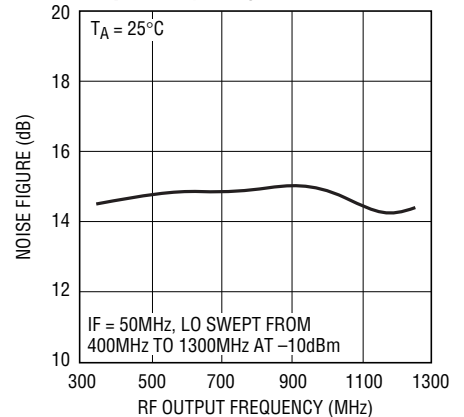

5511 G09

TYPICAL PERFORMANCE CHARACTERISTICS (950MHz Application)

$V_{CC} = 5V_{DC}$, EN = High, $T_A = 25^\circ C$, IF Input = 50MHz at -5dBm, LO Input = 1GHz at -10dBm, RF Output Measured at 950MHz, unless otherwise noted. For 2-Tone Measurements: 2nd IF Input = 51MHz at -5dBm. (Test Circuit Shown in Figure 2).

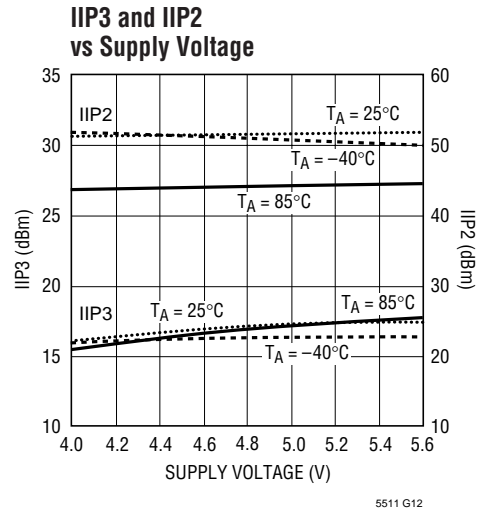
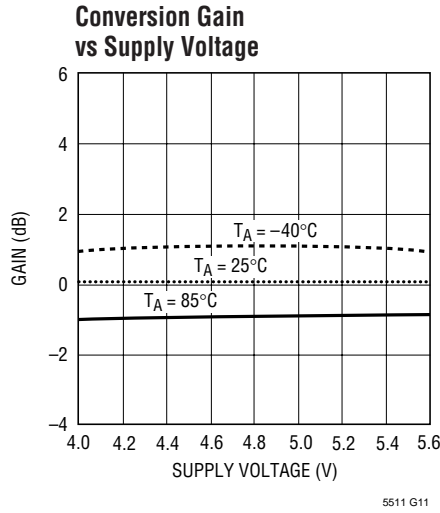
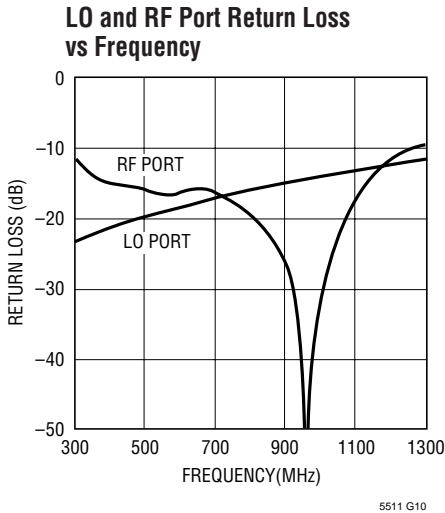

(1.9GHz Application)

$V_{CC} = 5V_{DC}$, EN = High, $T_A = 25^\circ C$, IF Input = 50MHz at -5dBm, LO Input = 1.95GHz at -10dBm, RF Output Measured at 1900MHz, unless otherwise noted. For 2-Tone Measurements: 2nd IF Input = 51MHz at -5dBm. (Test Circuit Shown in Figure 3).

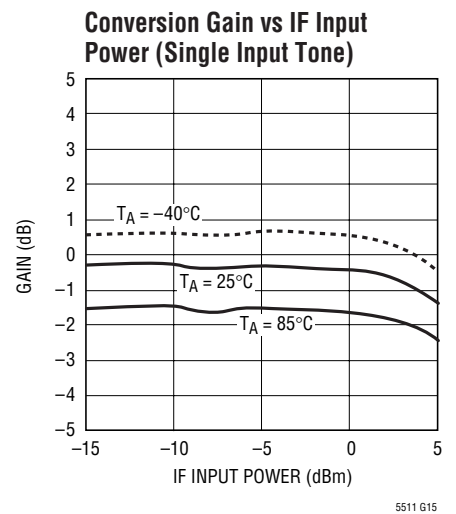
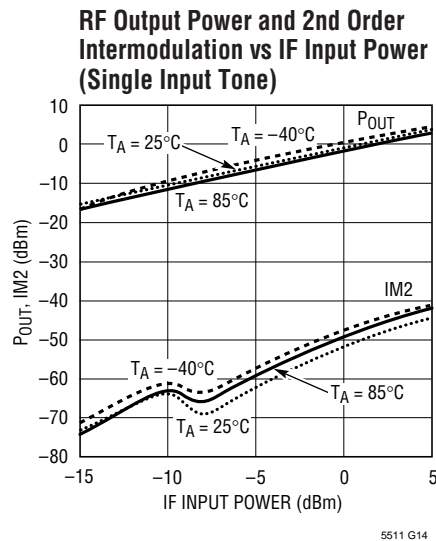
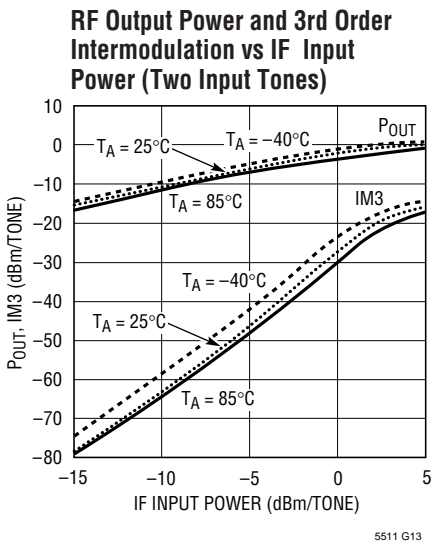

TYPICAL PERFORMANCE CHARACTERISTICS (1.9GHz Application)

$V_{CC} = 5V_{DC}$, $EN = High$, $T_A = 25^\circ C$, IF Input = 50MHz at -5dBm, LO Input = 1.95GHz at -10dBm. RF Output Measured at 1900MHz, unless otherwise noted. For 2-Tone Measurements: 2nd IF Input = 51MHz at -5dBm. (Test Circuit Shown in Figure 3).

Conversion Gain and IIP3 vs LO Input Power

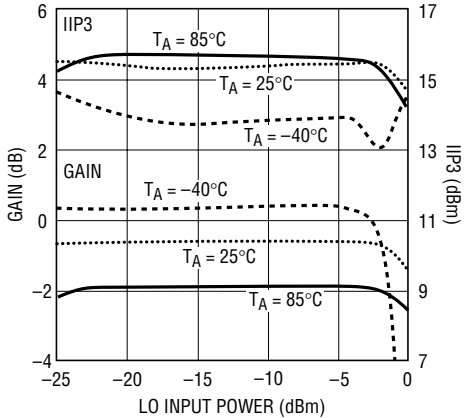

5511 G16

LO to RF Leakage vs LO Input Power

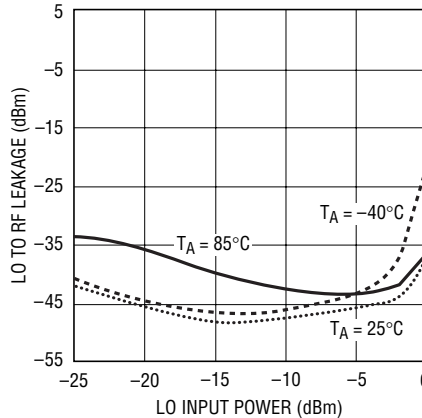

5511 G17

IIP2 vs LO Input Power

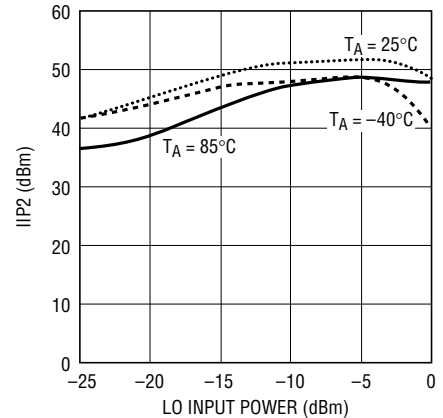

5511 G18

Conversion Gain and LO to RF Leakage vs RF Output Frequency

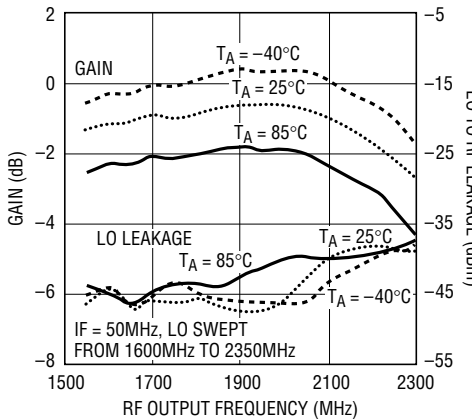

5511 G19

IIP3 and IIP2 vs Output Frequency

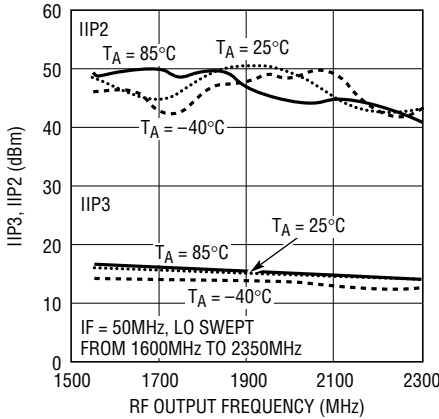

5511 G20

SSB Noise Figure vs Output Frequency

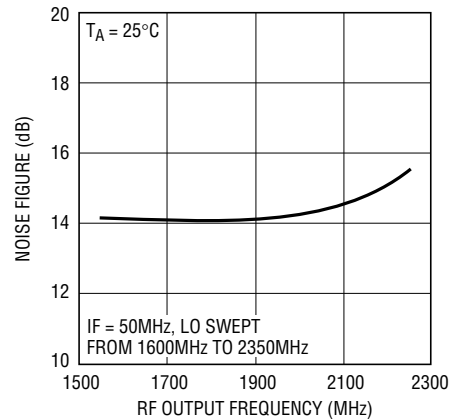

5511 G21

LO and RF Port Return Loss vs Frequency

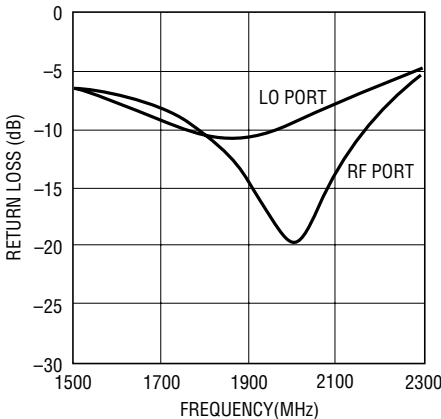

5511 G22

Conversion Gain vs Supply Voltage

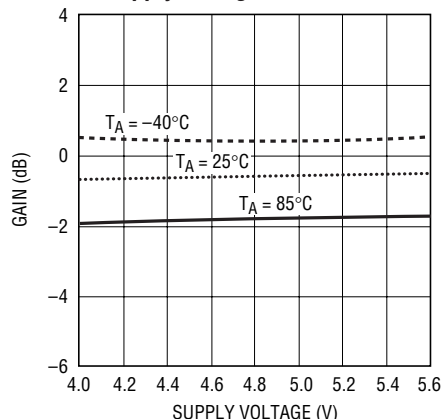

5511 G23

IIP3 and IIP2 vs Supply Voltage

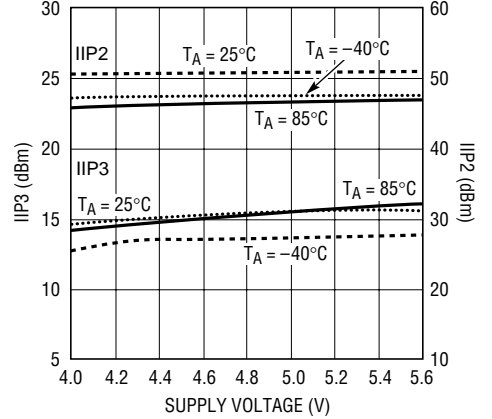

5511 G24

TYPICAL PERFORMANCE CHARACTERISTICS

Table 1. Typical S-Parameters for the IF, RF and LO Ports (referenced to 50Ω). $V_{CC} = 5V_{DC}$, EN = High, $T_A = 25^\circ C$. For each Port Measurement, the other Ports are Terminated as Shown in Figure 2.

Frequency (MHz)	Differential IF Port		Differential RF Port		Differential LO Port		Single LO Port	
	Mag.	Ang.	Mag.	Ang.	Mag.	Ang.	Mag.	Ang.
10	0.65	179.2	–	–	–	–	–	–
50	0.648	176.2	0.644	–0.8	0.814	–0.6	0.788	–1.0
100	0.645	173.3	0.643	–2.0	0.836	–0.8	0.808	–1.5
150	0.627	170.6	0.642	–3.0	0.804	–1.0	0.780	–2.1
200	0.626	168.5	0.642	–4.0	0.823	–1.6	0.789	–3.0
250	0.619	166.7	0.639	–5.0	0.803	–1.8	0.779	–3.7
300	0.617	165.0	0.635	–6.1	0.815	–2.5	0.773	–4.7
350	0.609	164.1	0.632	–7.2	0.806	–2.9	0.777	–5.9
400	0.597	162.7	0.629	–8.3	0.804	–3.8	0.760	–7.2
450	0.586	162.2	0.626	–9.5	0.805	–4.4	0.776	–8.9
500	0.567	161.3	0.623	–10.7	0.798	–5.2	0.749	–10.0
600	0.527	160.6	0.622	–13.0	0.797	–6.6	0.746	–12.9
700	0.484	160.0	0.620	–15.4	0.799	–7.8	0.750	–15.7
800	0.438	160.6	0.617	–18.0	0.804	–8.9	0.753	–18.0
900	0.451	167.8	0.615	–20.3	0.808	–9.6	0.756	–19.5
1000	0.554	162.3	0.613	–22.4	0.814	–10.2	0.763	–20.5
1100	0.581	150.0	0.611	–24.6	0.817	–10.7	0.765	–21.6
1200	0.574	141.4	0.607	–26.6	0.813	–11.2	0.755	–22.7
1300	0.567	137.2	0.602	–28.6	0.811	–12.2	0.751	–24.7
1400	0.557	135.1	0.594	–30.7	0.805	–13.7	0.743	–27.7
1500	0.540	135.6	0.585	–32.9	0.795	–15.6	0.731	–31.2
1600	0.520	136.5	0.576	–35.3	0.790	–18.0	0.727	–35.3
1700	0.495	136.9	0.567	–37.8	0.789	–20.6	0.726	–39.3
1800	0.462	135.3	0.557	–40.7	0.791	–22.9	0.728	–42.6
1900	0.432	131.0	0.548	–43.8	0.793	–24.8	0.728	–45.0
2000	0.405	124.4	0.540	–47.0	0.795	–26.2	0.728	–46.7
2100	0.390	116.1	0.529	–50.2	0.796	–27.3	0.724	–48.0
2200	0.366	108.1	0.521	–53.9	0.796	–28.4	0.718	–49.8
2300	0.310	110.2	0.513	–57.4	0.790	–29.8	0.703	–52.4
2400	0.417	127.5	0.503	–61.4	0.782	–31.8	0.687	–56.5
2500	0.489	121.5	0.495	–65.3	0.765	–34.8	0.668	–62.7
2600	0.491	122.0	0.486	–69.0	0.748	–38.8	0.656	–70.5
2700	0.472	126.7	0.479	–73.2	0.731	–43.3	0.652	–78.7
2800	0.445	132.0	0.472	–76.8	0.721	–48.3	0.663	–85.9
2900	0.412	138.9	0.468	–80.4	0.720	–52.5	0.680	–91.2
3000	0.375	142.4	0.463	–83.1	0.722	–55.9	0.701	–94.2

TEST CIRCUIT

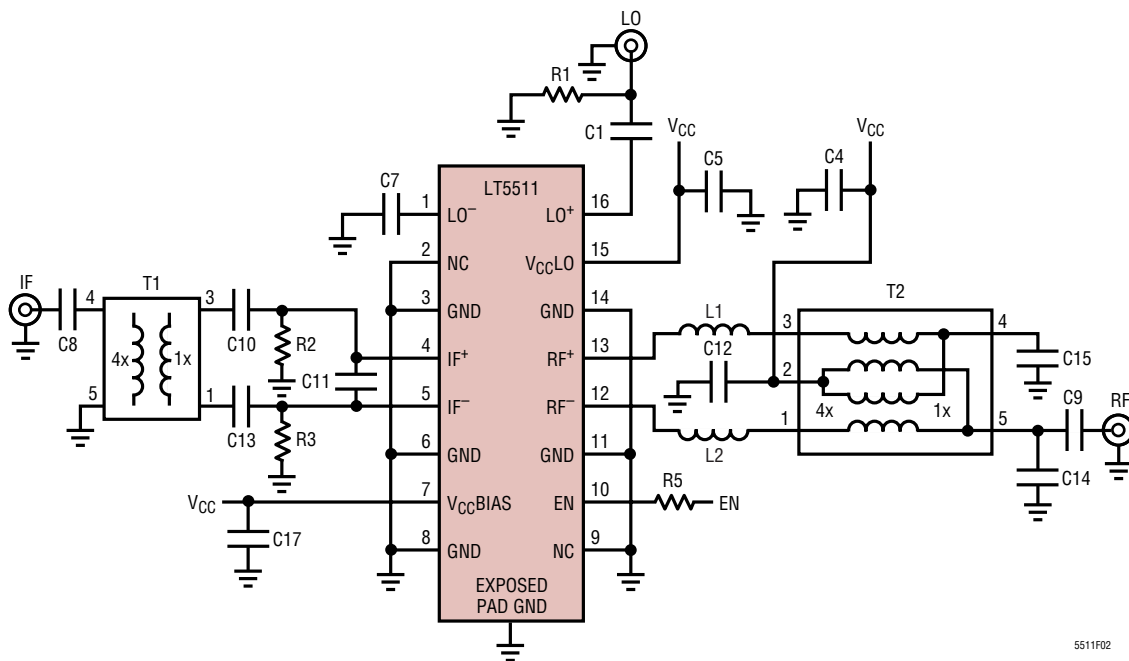

5511F02

Component	Value	Comments
C1, C9, C11, C15	22pF	0402
C5, C7, C17	100pF	0402
C4	0.1μF	0402
C8	220pF	0402
C10, C12, C13	1000pF	0402
C14	1.5pF	0402
L1, L2	6.8nH	0402
R1	62Ω	0402
R2, R3	75Ω, 0.1%	0603
R5	10kΩ	0402
T1	4:1	Coilcraft TTWB-4-A
T2	4:1	M/A-Com ETC1.6-4-2-3

Figure 2. Test Circuit and Evaluation Board Schematic for 950MHz Application.

TEST CIRCUIT

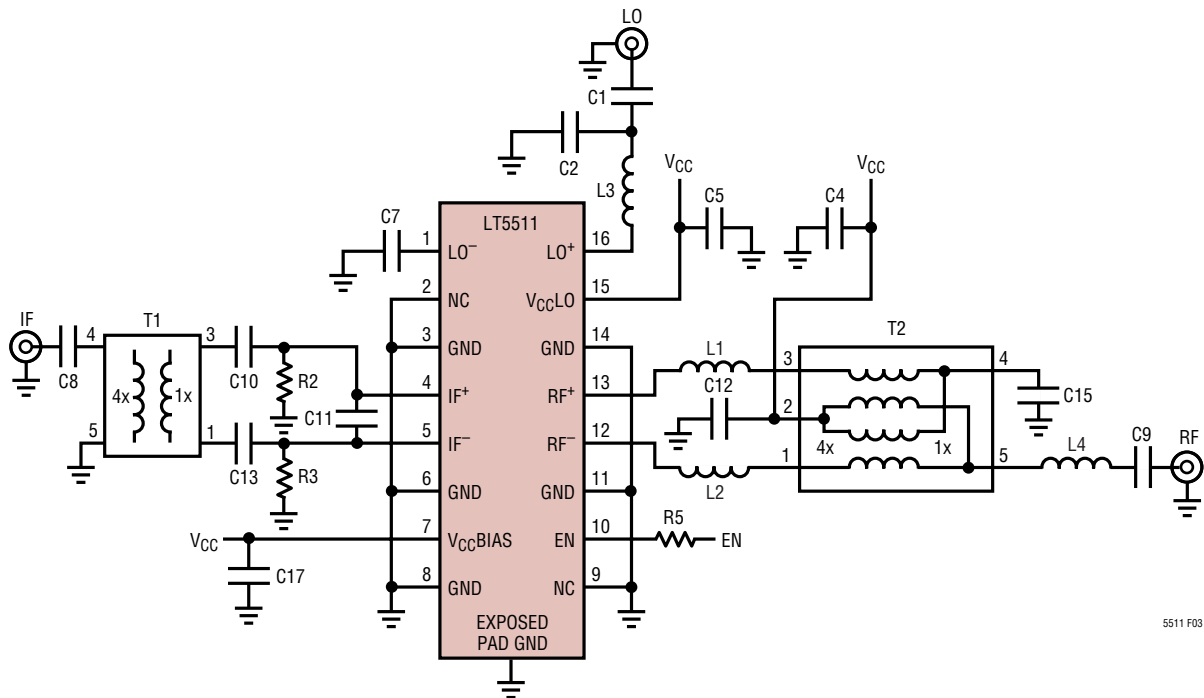

5511 F03

Component	Value	Comments
C1, C9, C11, C15	22pF	0402
C5, C7, C17	100pF	0402
C4	0.1μF	0402
C8	220pF	0402
C10, C12, C13	1000pF	0402
C2	1.2pF	0402
L3	6.8nH	0402
L1, L2	4.7nH	0402
L4	1.8nH	0402
R2, R3	75Ω, 0.1%	0603
R5	10kΩ	0402
T1	4:1	Coilcraft TTWB-4-A
T2	4:1	M/A-Com ETC1.6-4-2-3

Figure 3. Test Circuit and Evaluation Board Schematic for 1.9GHz Application.

APPLICATIONS INFORMATION

The LT5511 consists of a double-balanced mixer driven by a high-performance, differential, limiting LO buffer. The mixer has been optimized for high linearity and high signal level operation. The LT5511 is intended for applications with LO frequencies of 0.4GHz to 2.7GHz and IF input frequencies from 10MHz to 300MHz, but can be used at other frequencies with excellent results. The LT5511 can be used in applications using either a low side or high side LO.

LO Input Port

The LO buffer on the LT5511 consists of differential high speed amplifiers and limiters that are designed to drive the mixer quad to achieve high linearity and performance at high IF input signal levels. The LO⁺ and LO⁻ pins are the differential inputs to the LO buffer. Though the LO signal can be applied differentially, the LO buffer performs well with only one input driven, thus eliminating the need for a balun. In this case, a capacitor should be connected between the unused LO input pin and ground. The LO pins are biased internally to about 1.4V, and thus must be DC isolated from the external LO signal source.

The LO input should be matched to 50Ω. The impedance match can be accomplished through the use of a reactive impedance matching network. However, for lower LO frequencies (below about 1.5GHz), an easier approach is to use a shunt 62Ω resistor to resistively match the port. (The resistor must be DC isolated from the LO input pin). This method is broadband and requires LO power levels of only -10dBm. At higher frequencies, a better match can be realized with reactive components. Transmission lines and parasitics should be considered when designing the matching circuits. Typical S-parameter data for the LO input is included in Table 1 to facilitate the design of the matching network.

IF Input Port

The IF⁺ and IF⁻ pins are the differential inputs to the mixer. These inputs drive the emitters of the switching transistors, and thus have a low impedance. The DC current through these transistors is set by external resistors from each IF pin to ground. The typical internal voltage on the emitters is 1.2V; thus, the current through each IF pin is approximately:

$$I_{IF} = 1.2/R_{IF}$$

R_{IF} is the value of the external resistors to ground. Best performance is obtained when the IF inputs are perfectly balanced and 0.1% tolerance resistors are recommended here. The LT5511 has been characterized with 75Ω resistors on each of the IF inputs.

The IF signal to the mixer must be differential. To realize this, an RF balun transformer or lumped element balun can be used. The RF transformer is recommended, as it is easier to realize broadband operation, and also does not have the component sensitivity issues of a lumped element balun.

The differential input impedance of the IF input is approximately 12.5Ω; therefore, a 4:1 impedance transformation is required to match to 50Ω. Selecting a transformer with this impedance ratio will reduce the amount of additional components required, as the full impedance transformation is realized by the transformer. DC-isolating transformers or transmission-line transformers can be used, as could lumped element transformation networks. Because the IF ports are internally biased, they must be DC isolated from the IF source. Additionally, IF⁺ and IF⁻ must be DC isolated from each other in order to maintain good LO suppression.

APPLICATIONS INFORMATION

On the evaluation board (Figure 4), 1nF DC-blocking capacitors are used on the IF input pins. A 220pF capacitor on the 50Ω source side of the input balun is used to tune out the excess inductance to improve the match at 50MHz. To shift the match higher in frequency, this capacitor value should be reduced.

RF Output Port

The RF outputs, RF⁺ and RF⁻, are internally connected to the collectors of the mixer switching transistors. These differential output signals should be combined externally through an RF balun transformer or 180° hybrid to achieve

optimum performance. These pins are biased at the supply voltage, which can be applied through the center tap of the output transformer. (The center tap should be RF bypassed for best performance). A pair of series inductors can be used to match RF⁺ and RF⁻ to the high impedance (200Ω) side of a 4:1 balun.

The output balun has a significant impact on the performance of the mixer. A broadband balun provides better rejection of the 2f_{LO} spur. If the level of that spur is not critical, a less expensive and smaller balun can be used. The amplitude and phase balances of the balun will affect the LO suppression.

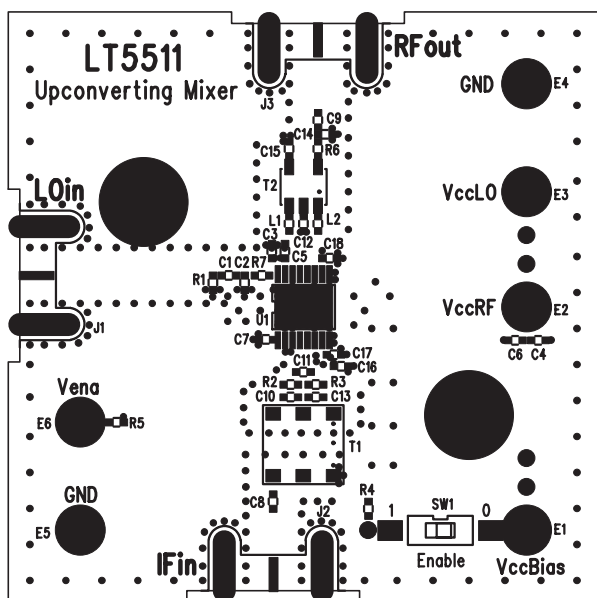

(4a) Top Layer Silkscreen

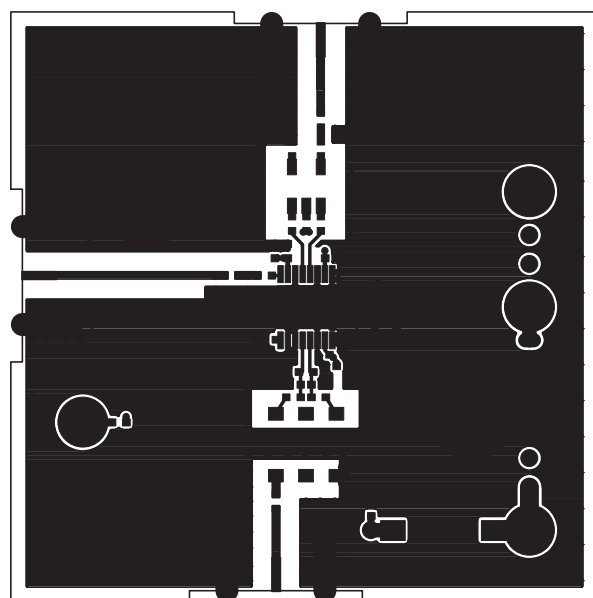

(4b) Top Layer Metal

Figure 4. Evaluation Board Layout.

APPLICATIONS INFORMATION

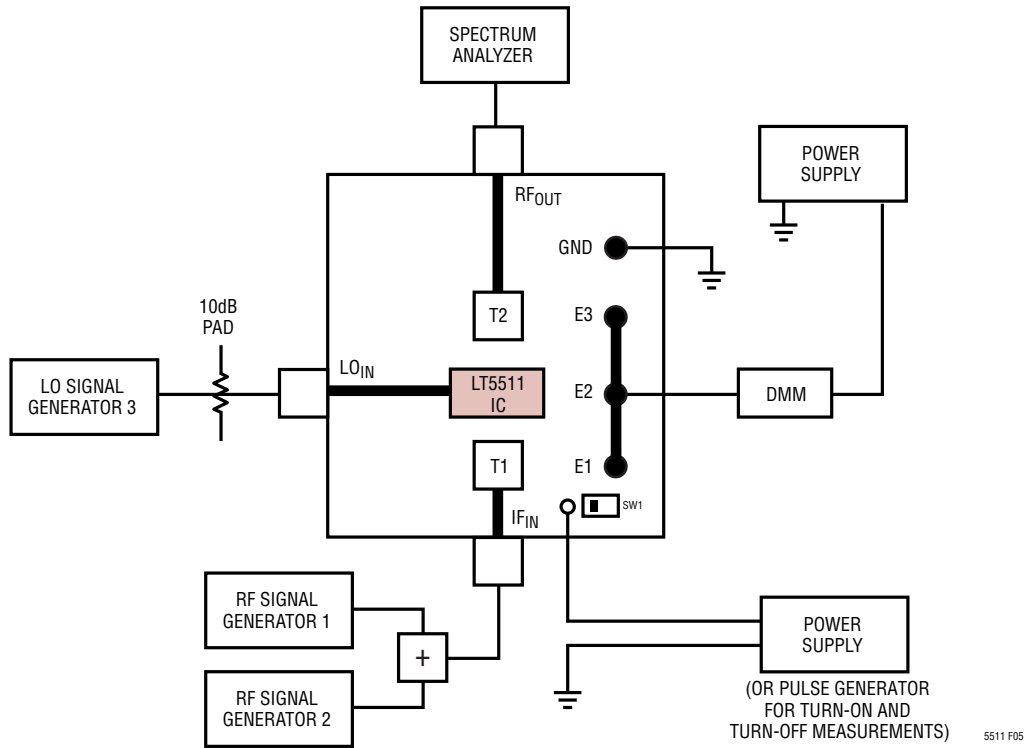
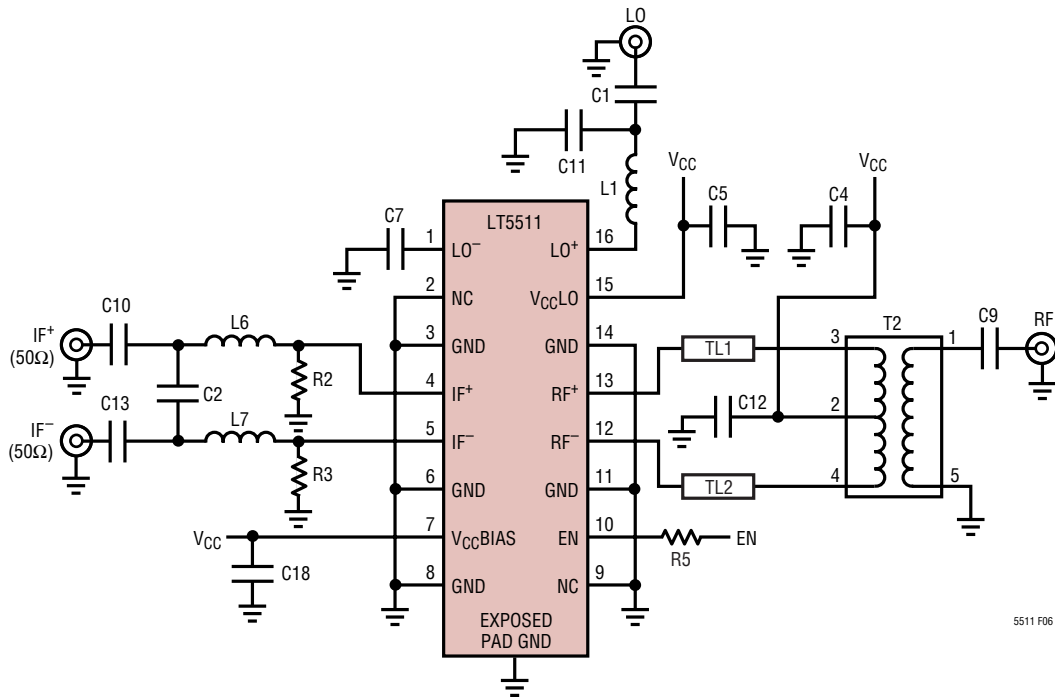

Figure 5. Test Set-Up for Mixer Measurements

TYPICAL APPLICATIONS



5511 F06

Component	Value	Comments
C1, C9	22pF	0402
C5, C7, C18	100pF	0402
C4	0.1μF	0402
C2	12pF	0402
C10, C12, C13	1000pF	0402
C11	1pF	0402
L1	5.2nH	0402
L6, L7	5.6nH	0402
R2, R3	75Ω, 0.1%	0603
R5	10kΩ	0402
T2	1:1	MURATA LDB15C500A2400
Transmission Lines		
TL1, TL2	Z ₀ = 80Ω	L = 16° AT 2.4GHz

Figure 6. Test Circuit Schematic for 2.4GHz RF Application with 300MHz IF Input Frequency

TYPICAL APPLICATIONS

Conversion Gain and LO to RF Leakage vs Output Frequency (Figure 6)

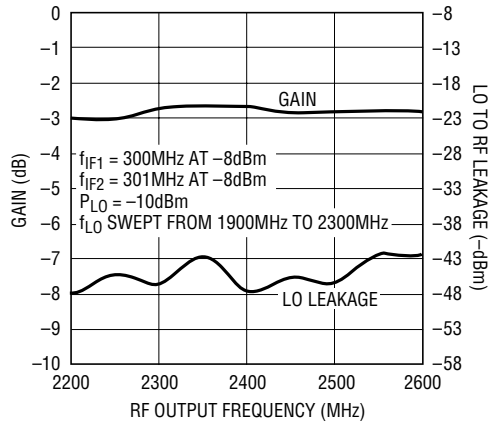

5511 F06a

IIP3 and IIP2 vs Output Frequency (Figure 6)

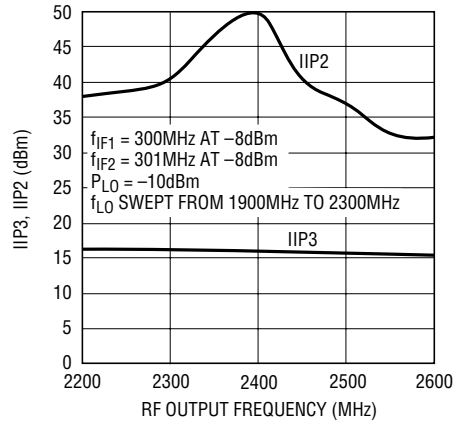

5511 F06a

PACKAGE DESCRIPTION

FE Package
16-Lead Plastic TSSOP (4.4mm)
 (Reference LTC DWG # 05-08-1663)
Exposed Pad Variation BA

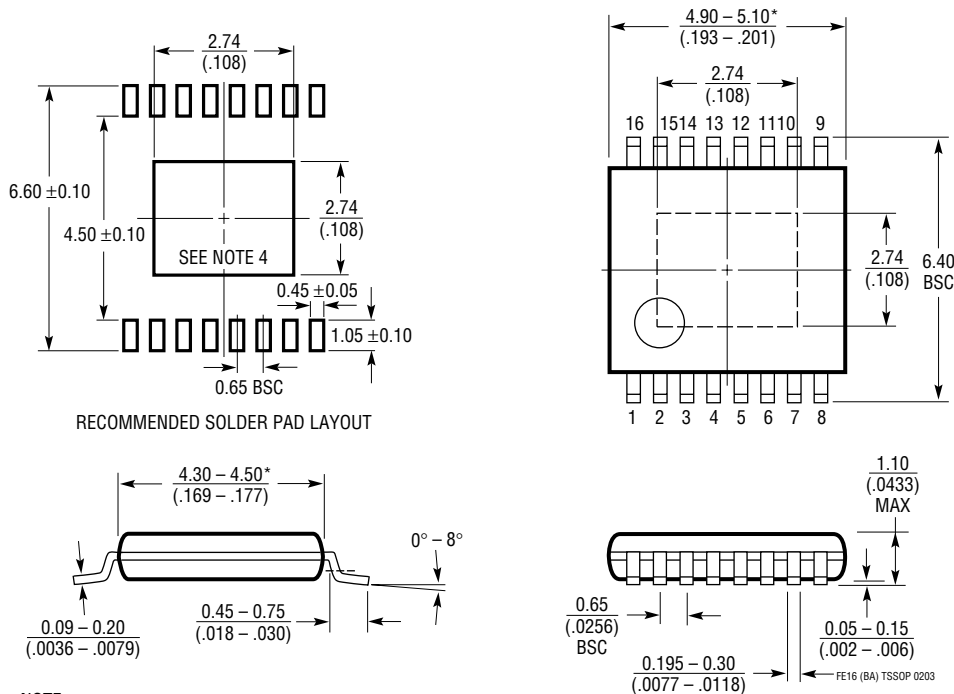

- NOTE:
 1. CONTROLLING DIMENSION: MILLIMETERS
 2. DIMENSIONS ARE IN $\frac{\text{MILLIMETERS}}{\text{(INCHES)}}$
 3. DRAWING NOT TO SCALE
 4. RECOMMENDED MINIMUM PCB METAL SIZE FOR EXPOSED PAD ATTACHMENT
 *DIMENSIONS DO NOT INCLUDE MOLD FLASH. MOLD FLASH SHALL NOT EXCEED 0.150mm (.006") PER SIDE

RELATED PARTS

PART NUMBER	DESCRIPTION	COMMENTS
LT5500	1.8GHz to 2.7GHz Receiver-Front End	1.8V to 5.25V Supply, Dual-Gain LNA, Mixer, LO Buffer
LT5502	400MHz Quadrature IF Demodulator with RSSI	1.8V to 5.25V Supply, 70MHz to 400MHz IF, 84dB Limiting Gain, 90db RSSI Range
LT5503	1.2GHz to 2.7GHz Direct IQ Modulator and Upconverting Mixer	1.8V to 5.25V Supply, Four-Step RF Power Control, 120MHz Modulation Bandwidth
LT5504	800MHz to 2.7GHz Measuring Receiver	80dB Dynamic Range, Temperature Compensated, 2.7V to 5.5V Supply
LTC [®] 5505	RF Power Detectors with >40dB Dynamic Range	300MHz to 3GHz, Temperature Compensated, 2.7V to 6V Supply
LT5506	500MHz Quadrature Demodulator with VGA	1.8V to 5.25V Supply, -4dB to 57dB Linear Power Gain
LT5507	100kHz to 1GHz RF Power Detector	48dB Dynamic Range, Temperature Compensated, 2.7V to 6V Supply
LTC5508	300MHz to 7GHz RF Power Detector	>40dB Dynamic Range, SC70 Package
LT5512	High Signal Level Down Converting Mixer	Up to 3GHz, 20dBm IIP3, Integrated LO Buffer

Looking for pricing, stock, or lifecycle information?

Click below to explore more details on WIN SOURCE:

 [View LT5511EFE#PBF on WIN SOURCE](#)

 [Linear Technology](#) Information

Optimize Your Supply Chain with WIN SOURCE Solutions

-  Global Sourcing Solution
-  Obsolete Management
-  Cost Control Management
-  Shortage Management
-  Alternative Solution
-  Excess Inventory Management