



**THE DATASHEET OF
LT3590EDC#TRMPBF**



48V Buck Mode LED Driver in SC70 and 2mm x 2mm DFN

FEATURES

- 4.5V to 55V Input Voltage Range
- Up to 50mA LED Current
- 80mA, 55V Switch
- Internal Schottky Diode
- 15 μ A Supply Current in Shutdown
- 500 μ A Supply Current Operating, Not Switching
- Switching Frequency: 850kHz
- 200mV Feedback Voltage with \pm 5% Accuracy
- CTRL Input Performs Dimming and Shutdown
- 91% Efficiency (10 LEDs, 50mA)
- Requires Only 1 μ F Output Capacitor
- 8-Lead SC70 Package
- 6-Lead 2mm \times 2mm DFN Package

APPLICATIONS

- LED Fixed Signage
- Traffic Signs
- Neon Sign Replacement

DESCRIPTION

The LT[®]3590 is a fixed frequency buck mode converter specifically designed to drive up to 10 LEDs in series from a 48V DC source. Series connection of the LEDs provides identical LED currents of up to 50mA, resulting in uniform brightness and eliminating the need for ballast resistors. A fixed frequency, current mode architecture results in stable operation over a wide range of input voltage and output voltage.

The high switching frequency of 850kHz permits the use of tiny, low profile inductors and capacitors. A single pin performs both shutdown and accurate LED dimming control. The power switch, Schottky diode and control circuitry are all contained inside a space saving SC70 package or 2mm \times 2mm DFN package to allow a small converter footprint and lower parts cost.

LT, LT, LTC and LTM are registered trademarks of Linear Technology Corporation. All other trademarks are the property of their respective owners.

TYPICAL APPLICATION

Buck Mode Driver for Ten White LEDs

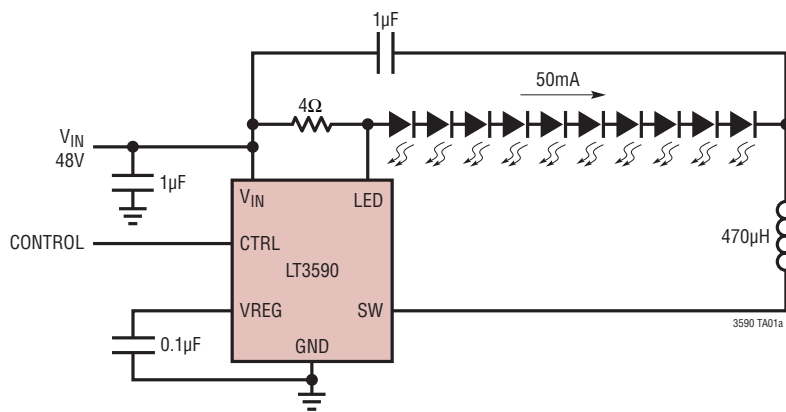

Conversion Efficiency

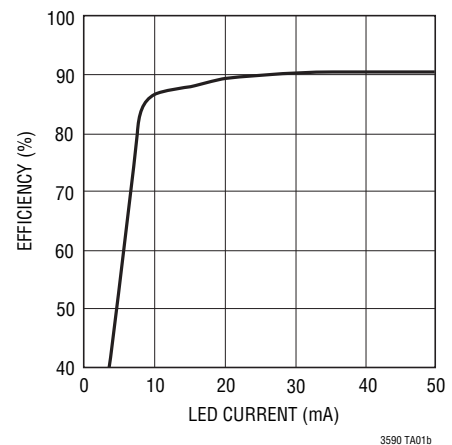

LT3590

ABSOLUTE MAXIMUM RATINGS

(Note 1)

Input Voltage (V_{IN}).....	-0.3V to 55V	Maximum Junction Temperature.....	125°C
LED Voltage	-0.3V to 55V	Storage Temperature Range.....	-65°C to 150°C
CTRL Voltage	0V to 6.0V	Lead Temperature (Soldering, 10 sec)	
VREG Voltage.....	0V to 4.0V	SC 8 Package Only.....	300°C
Operating Junction Temperature Range			
(Note 2)	-40°C to 85°C		

PIN CONFIGURATION

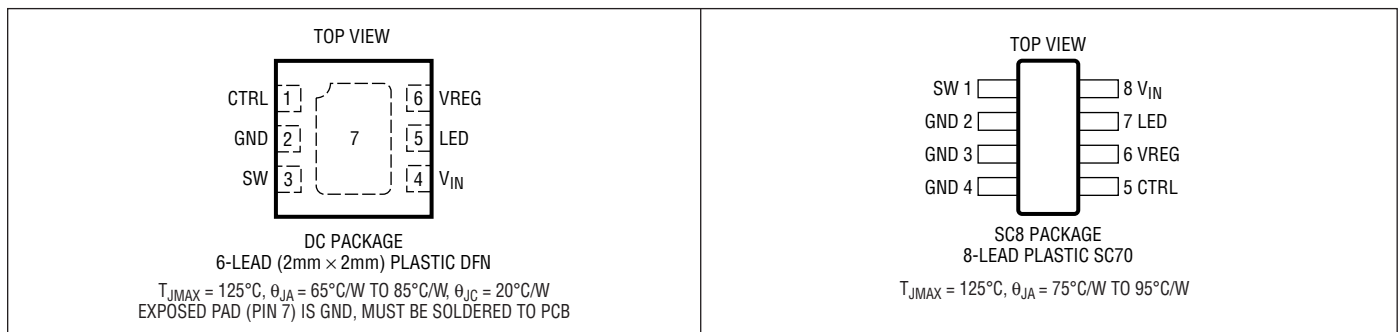

ORDER INFORMATION

LEAD FREE FINISH	TAPE AND REEL	PART MARKING	PACKAGE DESCRIPTION	TEMPERATURE RANGE
LT3590EDC#PBF	LT3590EDC#TRPBF	LCNZ	6-Lead (2mm × 2mm) Plastic DFN	-40°C to 85°C
LT3590ESC8#PBF	LT3590ESC8#TRPBF	LCPB	8-Lead Plastic SC70	-40°C to 85°C

Consult LTC Marketing for parts specified with wider operating temperature ranges.

Consult LTC Marketing for information on non-standard lead based finish parts.

For more information on lead free part marking, go to: <http://www.linear.com/leadfree/>

For more information on tape and reel specifications, go to: <http://www.linear.com/tapeandreeel/>

ELECTRICAL CHARACTERISTICS The ● denotes the specifications which apply over the full operating temperature range, otherwise specifications are at $T_A = 25^\circ\text{C}$, $V_{IN} = 48\text{V}$, $V_{CTRL} = 3.3\text{V}$, unless otherwise noted.

PARAMETER	CONDITIONS	MIN	TYP	MAX	UNITS
Minimum Operating Voltage		4.5			V
LED Current Sense Voltage ($V_{IN} - V_{LED}$)		● 190	200	210	mV
Sense Voltage Load Regulation	$\Delta I_{LED} = 10\text{mA to } 50\text{mA}$		5		mV
Quiescent Current ON, No Switching	$V_{LED} = 47.7\text{V}$		500	700	μA
Quiescent Current in Shutdown	$V_{CTRL} = 0\text{V}$		15	20	μA
Switching Frequency		● 650	850	1050	kHz
Maximum Duty Cycle		● 90			%
Switch Current Limit		80	115	150	mA
Switch V_{CESAT}	$I_{SW} = 50\text{mA}$		500		mV
Switch Leakage Current	$V_{SW} = 48\text{V}$		1	2	μA
V_{CTRL} for Full LED Current		● 1.5			V
V_{CTRL} to Shut Down IC				100	mV
V_{CTRL} to Turn on IC		150			mV
CTRL Pin Bias Current	$V_{CTRL} = 1\text{V}$, Current Out of Pin		100		nA
LED Pin Bias Current	$V_{LED} = 47.8\text{V}$		9	14	μA
LDO Voltage V_{REG}	$I_{VREG} = 1\text{mA}$	3.1	3.3	3.5	V
LDO Load Regulation	$\Delta I_{VREG} = 0\text{mA to } 1\text{mA}$		17		mV
LDO Current Limit		1.5			mA
Schottky Forward Drop	$I_{SCHOTTKY} = 50\text{mA}$		0.8		V
Schottky Leakage Current	$V_R = 48\text{V}$			4	μA

Note 1: Stresses beyond those listed under Absolute Maximum Ratings may cause permanent damage to the device. Exposure to any Absolute Maximum Rating condition for extended periods may affect device reliability and lifetime.

Note 2: The LT3590E is guaranteed to meet performance specifications from 0°C to 85°C junction temperature. Specifications over the -40°C to 85°C operating junction temperature range are assured by design, characterization and correlation with statistical process controls.

TYPICAL PERFORMANCE CHARACTERISTICS

Switch Saturation Voltage (V_{CESAT})

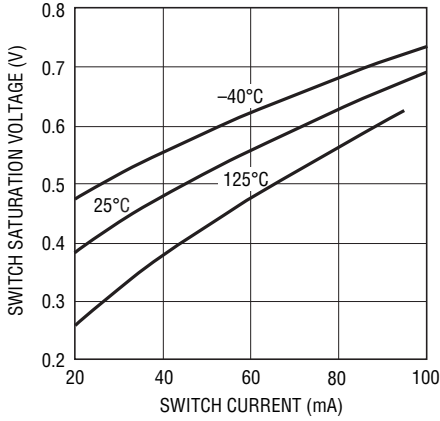

3590 G01

Schottky Forward Voltage Drop

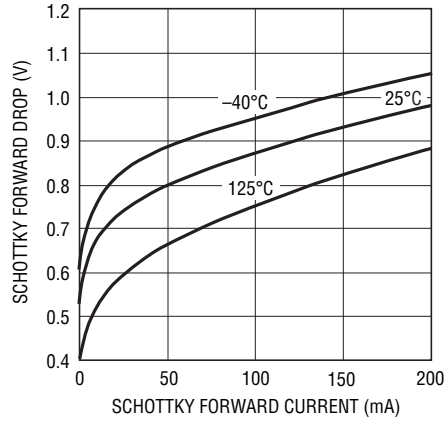

3590 G02

Shutdown Quiescent Current vs V_{IN}

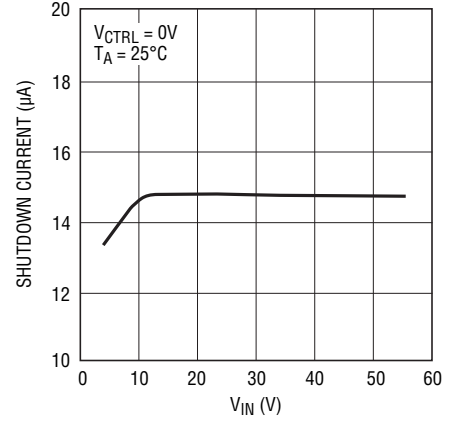

3590 G03

Shutdown Quiescent Current vs Temperature

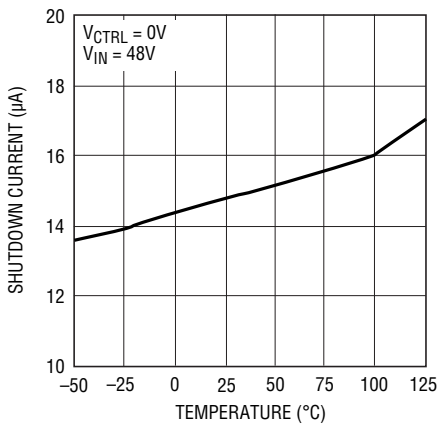

3590 G04

Quiescent Current

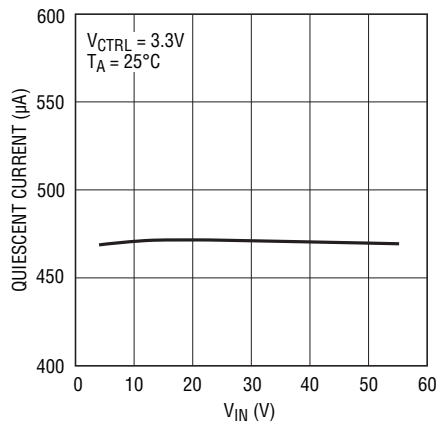

3590 G05

Schottky Leakage Current

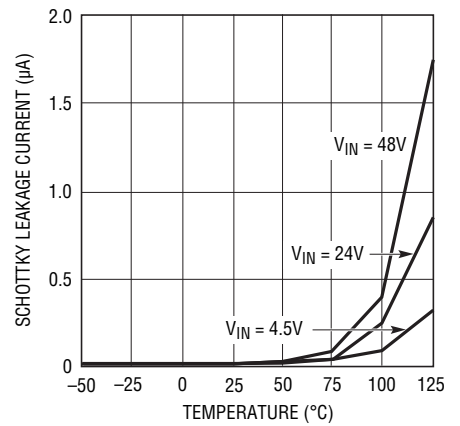

3590 G06

Switching Waveform

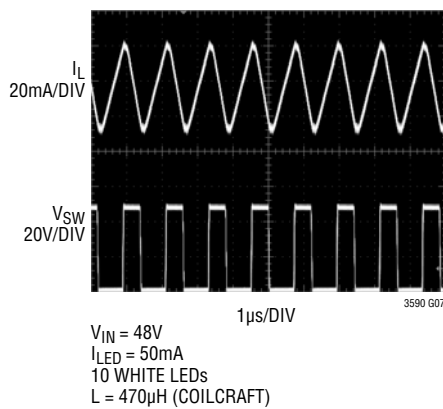

3590 G07

Transient Response

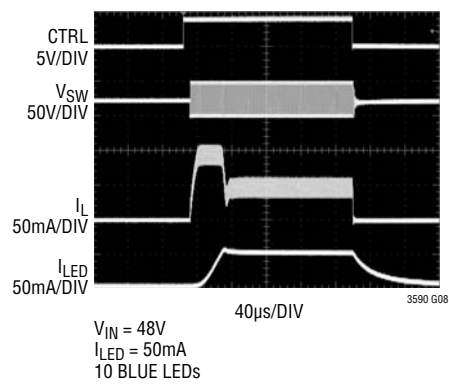

3590 G08

TYPICAL PERFORMANCE CHARACTERISTICS

Sense Voltage ($V_{IN} - V_{LED}$) vs V_{CTRL}

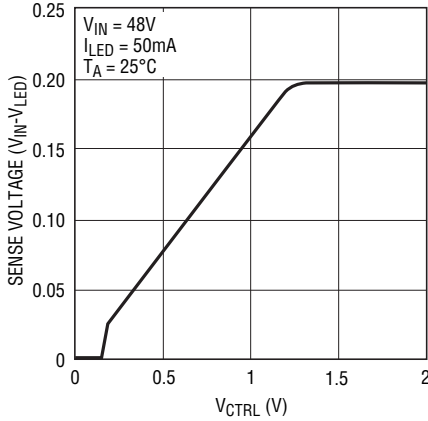

3590 G09

Switching Current Limit vs Duty Cycle

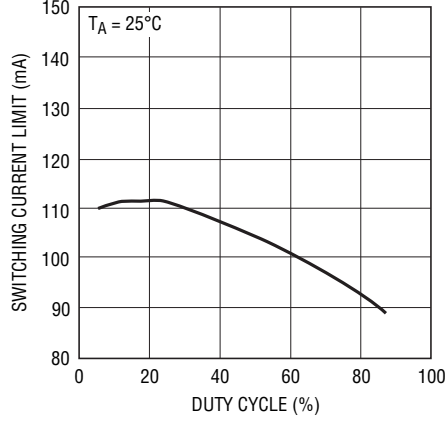

3590 G10

Switching Current Limit vs Temperature

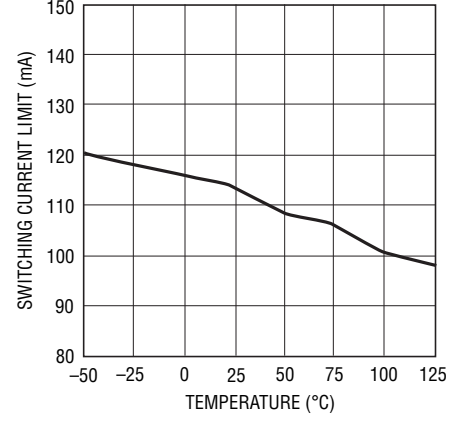

3590 G11

Sense Voltage ($V_{IN} - V_{LED}$) vs V_{IN}

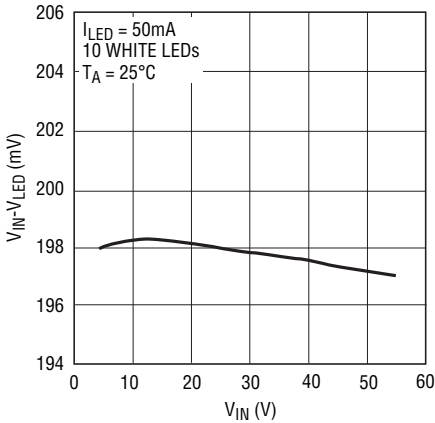

3590 G12

Sense Voltage ($V_{IN} - V_{LED}$) vs Temperature

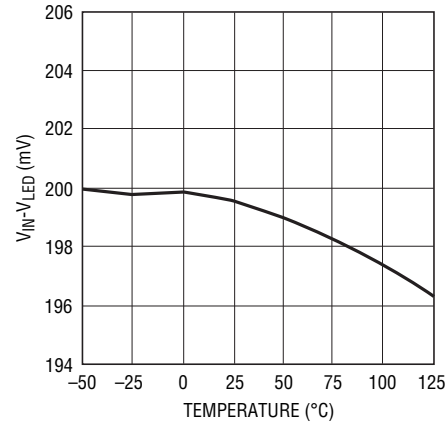

3590 G13

Switching Frequency over Temperature

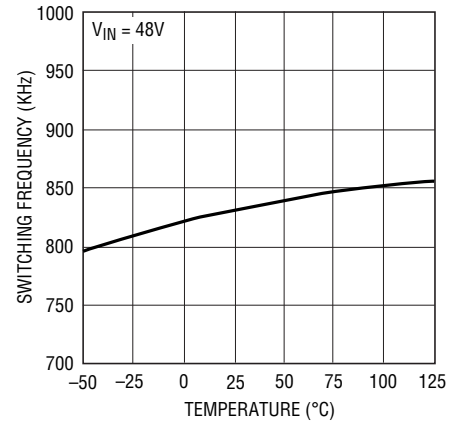

3590 G14

Internal Regulator Line Regulation

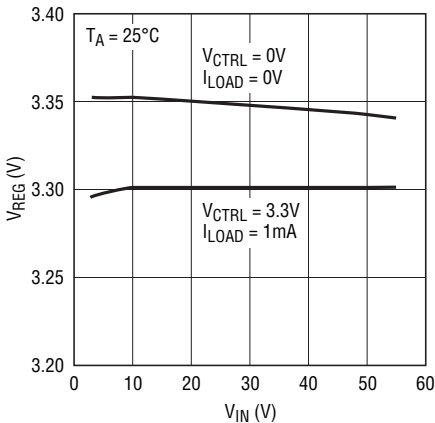

3590 G15

Internal Regulator Load Regulation

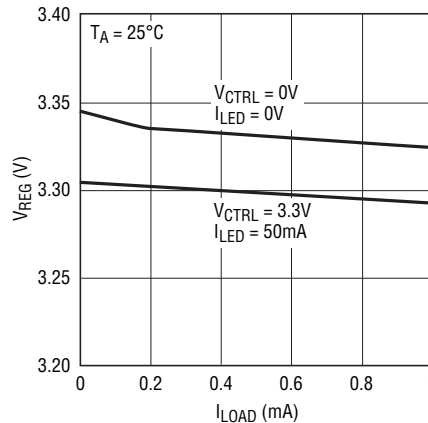

3590 G16

Internal Regulator V_{REG} vs Temperature

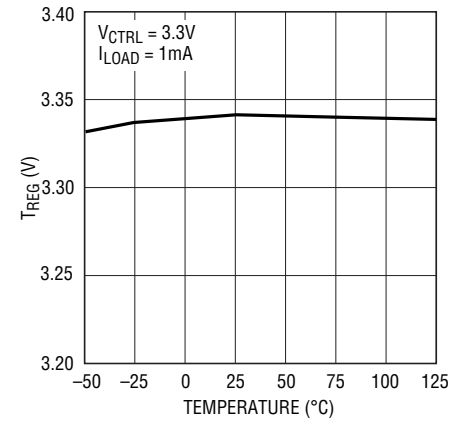

3590 G17

PIN FUNCTIONS (SC70/DFN)

SW (Pin 1/Pin 3): Switch Pin. Minimize trace area at this pin to minimize EMI. Connect the inductor at this pin.

GND (Pins 2, 3, 4/Pin 2): Ground Pins. All ground pins should be tied directly to local ground plane. Proper soldering of these pins to the PCB ground is required to achieve the rated thermal performance.

CTRL (Pin 5/Pin 1): Dimming and Shutdown Pin. Connect it below 100mV to disable the switcher. As the pin voltage is ramped from 0V to 1.5V, the feedback voltage ($V_{IN} - V_{LED}$) ramps from 0mV to 200mV, controlling the LBD current.

$$I_{LED} = \frac{V_{IN} - V_{LED}}{R1}$$

VREG (Pin 6/Pin 6): Internally Generated 3.3V Regulated Output Pin. Must be locally bypassed with a 0.1µF X5R capacitor.

LED (Pin 7/Pin 5): Connection point for the anode of the highest LED and the sense resistor.

V_{IN} (Pin 8/Pin 4): Input Supply Pin. Must be locally bypassed.

Exposed Pad (NA/Pin 7): Ground. The Exposed Pad should be soldered to the PCB ground to achieve the rated thermal performance.

BLOCK DIAGRAM

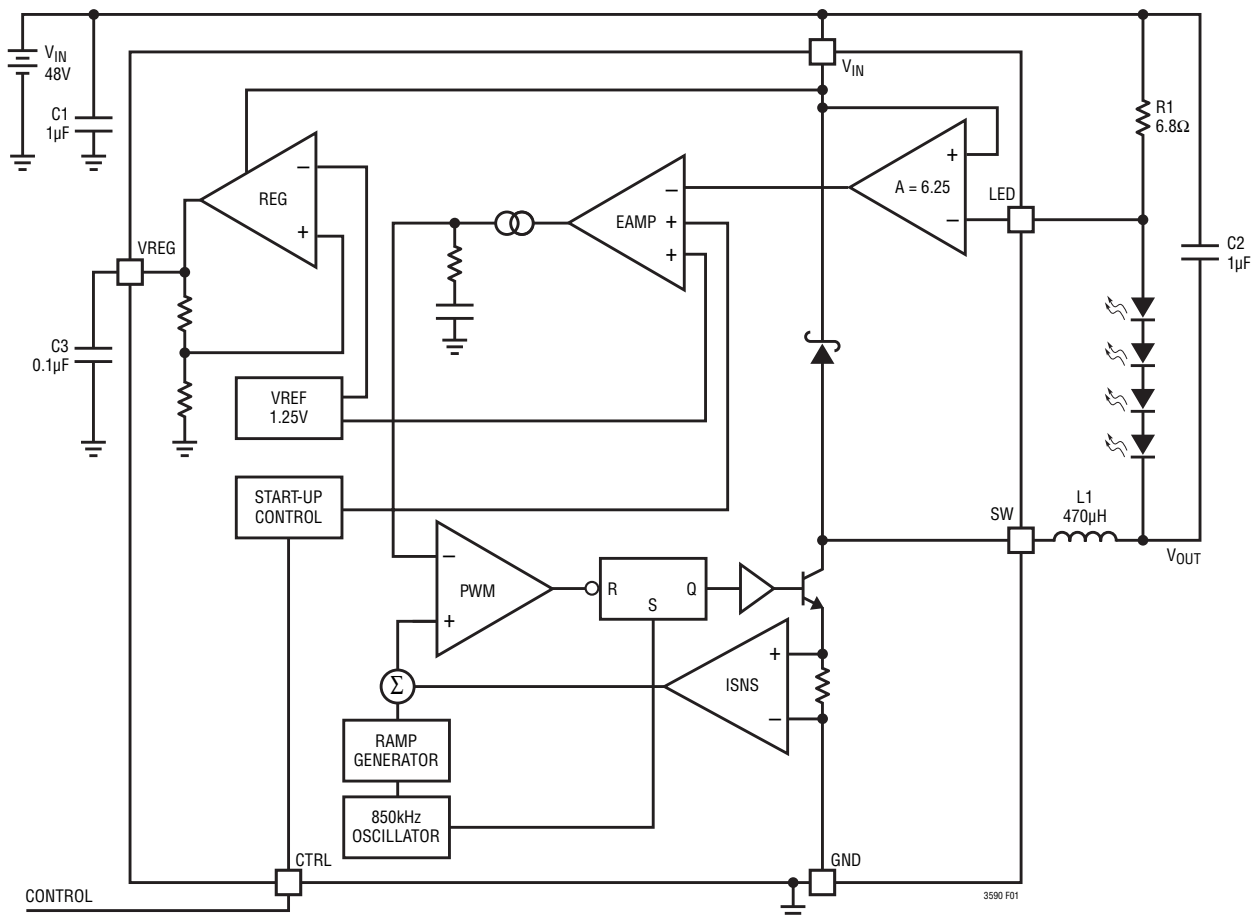

Figure 1. Block Diagram

OPERATION

The LT3590 uses a constant-frequency, current mode control scheme to provide excellent line and load regulation. Operation can be best understood by referring to the Block Diagram.

At power-up, the bandgap reference, the start-up bias, and the regulator are turned on. If CTRL is pulled higher than 150mV, the switching converter sub-blocks including the oscillator, the PWM comparator and the error amplifier are also turned on. At the start of each oscillator cycle, the power switch Q1 is turned on. Current flows through the inductor and the switch to ground, ramping up as the switch stays on. A voltage proportional to the switch current is added to a stabilizing ramp and the resulting sum is fed into the positive terminal of the PWM comparator. When this voltage exceeds the level at the negative input of the PWM comparator, the PWM logic turns off the power switch. The level at the negative input of the PWM comparator is set by the error amplifier EAMP, and is simply an amplified version of the difference between the V_{IN} and V_{LED} voltage and the bandgap reference. In this manner, the error amplifier sets the correct peak current level in inductor L1 to keep the output in regulation. The CTRL pin is used to adjust the reference voltage.

The LT3590 enters into shutdown when CTRL is pulled lower than 100mV.

Input Voltage Range

The minimum input voltage required to generate a particular output voltage in an LT3590 application is limited by either its 4.5V limit or by its maximum duty cycle. The duty cycle is the fraction of time that the internal switch is on and is determined by the input and output voltages:

$$DC = \frac{V_{LED} + V_D}{V_{IN} - V_{SW} + V_D}$$

Where V_D is the forward voltage drop of the catch diode (~0.8V) and V_{SW} is the voltage drop of the internal switch at maximum load (~0.5V). Given $DC_{MAX} = 0.9$, this leads to minimum input voltage of:

$$V_{IN(MIN)} = \frac{(V_{LED} + V_D)}{DC_{MAX}} + V_{SW} - V_D$$

The maximum input voltage is limited by the absolute maximum V_{IN} rating of 55V.

Pulse-Skipping

For LED strings with a low number of LEDs (1, 2, or 3), the LT3590 can drive currents without pulse-skipping as long as the voltage across the LED and sense resistor is greater than roughly 15% of the input supply voltage. If the LED voltage plus sense resistor is less than 15% of the input supply, the device will begin skipping pulses. This will result in some low frequency ripple, although the LED current remains regulated on an average basis down to zero.

Discontinuous Current Mode

The CTRL pin, in conjunction with the sense resistor, can be used to program the LED current as discussed under Applications Information. The LT3590 can drive a 10-LED string at 10mA LED current operating in continuous conduction mode, using the recommended external components shown in the front page application circuit with the sense resistor equal to 10Ω. As current is further reduced, the regulator enters discontinuous conduction mode. The photo in Figure 2 details circuit operation driving ten LEDs at 2mA load. During the discharge phase, the inductor current reaches zero. After the inductor current reaches zero, the SW pin exhibits ringing due to the LC tank circuit formed by the inductor in combination with the switch and the diode capacitance. This ringing is not harmful; far less spectral energy is contained in the ringing than in the switch transitions. The ringing can be damped by application of a 3kΩ resistor across the inductor, although this will degrade efficiency.

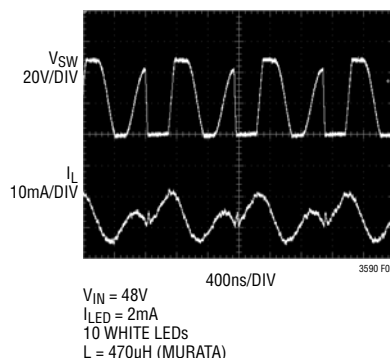

Figure 2. Switching Waveforms

APPLICATIONS INFORMATION

Inductor Selection

A 220 μ H inductor is recommended for most LT3590 applications with $V_{IN} < 25V$ and 470 μ H is recommended for applications with $V_{IN} > 25V$. Although small size and high efficiency are major concerns, the inductor should have low core losses at 850kHz and low DCR (copper wire resistance). Several manufacturers and inductor series that meet these criteria are listed in Table 1. The efficiency comparison of different inductors is shown in Figure 3.

Table 1. Inductor Manufacturers

VENDOR	PART SERIES	INDUCTANCE RANGE (μ H) (RELEVANT TO THIS PART)	DIMENSIONS (mm)
Coilcraft www.coilcraft.com	DO1605	100 TO 680	5.4 × 4.2 × 1.8
	LPS4012	100 TO 680	4.0 × 4.0 × 1.2
	LPS3010	100 TO 330	3.0 × 3.0 × 0.9
	1812FS	100 TO 680	
	MSS5131	100 TO 390	5.1 × 5.1 × 3.1
Sumida www.sumida.com	CDC4D20	100 TO 680	4.8 × 4.8 × 2.0
Toko www.tokoam.com	LLQ1608	100 TO 270	
	LLQ2012	100 TO 680	
Würth Elektronik www.we-online.com	WE-PD2 TYPE M	100 TO 220	5.2 × 5.8 × 4.5
	WE-PD2 TYPE L	100 to 470	7.0 × 7.8 × 5.0
Coiltronics www.cooperet.com	CTX32C	100 to 330	2.5 × 3.2 × 2.2
Murata www.murata.com	LQH32M	100 to 560	3.2 × 2.5 × 2.0
	LQH43M	100 to 680	4.5 × 3.2 × 2.0

Capacitor Selection

The small size of ceramic capacitors make them ideal for LT3590 applications. X5R and X7R types are recommended because they retain their capacitance over wider voltage and temperature ranges than other types such as Y5V or Z5U. A 1 μ F input capacitor and a 0.1 μ F regulator capacitor are sufficient for most applications. For the output capacitor, 1 μ F is generally recommended, but if the voltage across the capacitor exceeds 10V, a 0.47 μ F capacitor may be used instead. For applications driving one or two LEDs a 2.2 μ F output capacitor is needed.

Table 2 shows a list of several ceramic capacitor manufacturers. Consult the manufacturers for detailed information on their entire selection of ceramic parts.

Table 2: Recommended Ceramic Capacitor Manufacturers

Taiyo Yuden	(408) 573-4150 www.t-yuden.com
AVX	(803) 448-9411 www.avxcorp.com
Murata	(714) 852-2001 www.murata.com
Kemet	(408) 986-0424 www.kemet.com

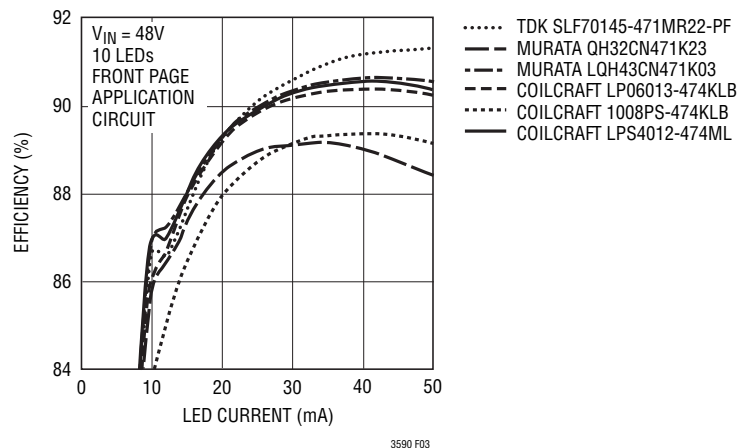

Figure 3. Efficiency Comparison of Different Inductors

APPLICATIONS INFORMATION

Programming LED Current

The feedback resistor (R1 in Figure 1) and the sense voltage ($V_{IN} - V_{LED}$) control the LED current.

$$I_{LED} = \frac{V_{IN} - V_{LED}}{R1}$$

The CTRL pin controls the sense reference voltage as shown in the Typical Performance Characteristics. For CTRL higher than 1.5V, the sense reference is 200mV, which results in full LED current. In order to have accurate LED current, precision resistors are preferred (1% is recommended). The formula and table for R1 selection are shown below.

$$R1 = \frac{200mV}{I_{LED}}$$

Table 3. R1 Theoretical Value for 200mV Sense

I_{LED} (mA)	R1 (Ω)
10	20
20	10
30	6.8
40	5.0
50	4.0

Dimming Control

There are three different types of dimming control circuits. The LED current can be set by modulating the CTRL pin with a DC voltage, a filtered PWM signal or directly with a PWM signal.

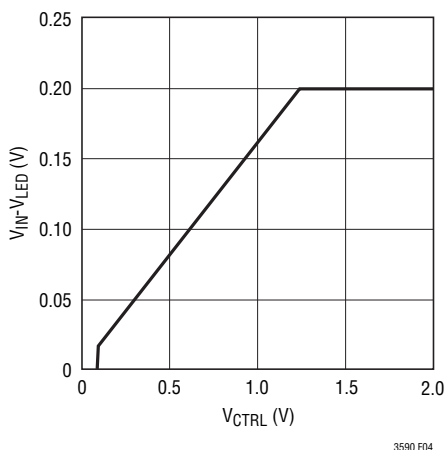

Figure 4. Dimming and Shutdown Using CTRL Pin

Using a DC Voltage

For some applications, the preferred method of brightness control is a variable DC voltage to adjust the LED current. The CTRL pin voltage can be modulated to set the dimming of the LED string. As the voltage on the CTRL pin increases from 0V to 1.5V, the LED current increases from 0 to I_{LED} . As the CTRL pin voltage increases beyond 1.5V, it has no effect on the LED current.

The LED current can be set by:

$$I_{LED} = \frac{200mV}{R1}, \text{ when } V_{CTRL} > 1.5V$$

$$I_{LED} = \frac{V_{CTRL}}{6.25 \cdot R1}, \text{ when } V_{CTRL} < 1.25V$$

Feedback voltage variation versus control voltage is shown in Figure 4.

Using a Filtered PWM Signal

A variable duty cycle PWM can be used to control the brightness of the LED string. The PWM signal is filtered (Figure 5) by a RC network and fed to the CTRL pin.

The corner frequency of R1, C1 should be much lower than the frequency of the PWM signal. R1 needs to be much smaller than the internal impedance in the CTRL pin which is 100k Ω .

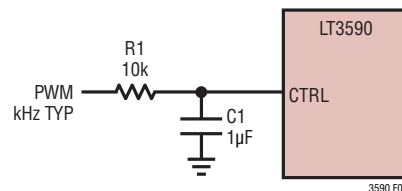

Figure 5. Dimming Control Using a Filtered PWM Signal

APPLICATIONS INFORMATION

Direct PWM Dimming

Changing the forward current flowing in the LEDs not only changes the intensity of the LEDs, it also changes the color. The chromaticity of the LEDs changes with the change in forward current. Many applications cannot tolerate any shift in the color of the LEDs. Controlling the intensity of the LEDs with a direct PWM signal allows dimming of the LEDs without changing the color. In addition, direct PWM dimming offers a wider dimming range to the user.

Dimming the LEDs via a PWM signal essentially involves turning the LEDs on and off at the PWM frequency. The typical human eye has a limit of ~60 frames per second. By increasing the PWM frequency to ~80Hz or higher, the eye will interpret that the pulsed light source is continuously on. Additionally, by modulating the duty cycle (amount of “on-time”), the intensity of the LEDs can be controlled. The color of the LEDs remains unchanged in this scheme since the LED current value is either zero or a constant value.

The time it takes for the LED current to reach its programmed value sets the achievable dimming range for a given PWM frequency. For example, the settling time of the LED current in Figure 6 is approximately 50µs for a

48V input voltage. The achievable dimming range for this application and 100Hz PWM frequency can be determined using the following method.

Example:

$$f = 100\text{Hz}, t_{\text{SETTLE}} = 50\mu\text{s}$$

$$t_{\text{PERIOD}} = \frac{1}{f} = \frac{1}{100} = 0.01\text{s}$$

$$\text{Dim Range} = \frac{t_{\text{PERIOD}}}{t_{\text{SETTLE}}} = \frac{0.01\text{s}}{50\mu\text{s}} = 200:1$$

$$\text{Min Duty Cycle} = \frac{t_{\text{SETTLE}}}{t_{\text{PERIOD}}} \cdot 100 = \frac{50\mu\text{s}}{0.01\text{s}} \cdot 100 = 0.5\%$$

$$\text{Duty Cycle Range} = 100\% \rightarrow 0.5\% \text{ at } 100\text{Hz}$$

The calculations show that for a 100Hz signal the dimming range is 200 to 1. In addition, the minimum PWM duty cycle of 0.5% ensures that the LED current has enough time to settle to its final value. Figure 7 shows the dimming range achievable for three different frequencies with a settling time of 50µs.

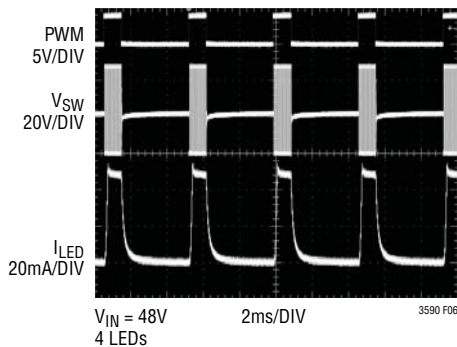

Figure 6. Direct PWM Dimming Waveforms

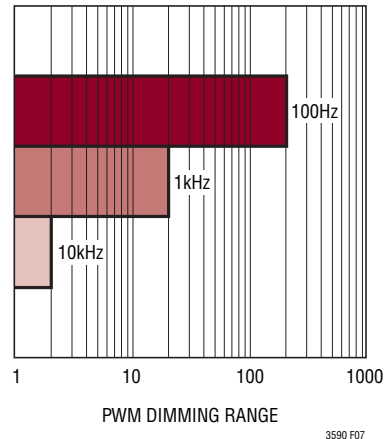

Figure 7. Dimming Range Comparison of Three PWM Frequencies

APPLICATIONS INFORMATION

The dimming range can be further extended by changing the amplitude of the PWM signal. The height of the PWM signal sets the commanded sense voltage across the sense resistor through the CTRL pin. In this manner both analog dimming and direct PWM dimming extend the dimming range for a given application. The color of the LEDs no longer remains constant because the forward current of the LED changes with the height of the CTRL signal. For the ten LED application described above, the LEDs can be dimmed first, modulating the duty cycle of the PWM signal. Once the minimum duty cycle is reached, the height of the PWM signal can be decreased below 1.5V down to 150mV. The use of both techniques together allows the average LED current for the ten LED application to be varied from 50mA down to less than 50 μ A.

Internal Voltage Regulator

The LT3590 has a 3.3V onboard voltage regulator capable of sourcing up to 1mA of current for use by an external device. This feature may be used to power-up a controller from the LT3590. The 3.3V is available even during shut-down. It is required to place a 0.1 μ F capacitor from V_{REG} to ground. The regulator current is limited to 1.5mA.

Board Layout Considerations

As with all switching regulators, careful attention must be paid to the PCB board layout and component placement. To prevent electromagnetic interference (EMI) problems, proper layout of high frequency switching paths is essential. Minimize the length and area of all traces connected to the switching node pin (SW). Keep the sense voltage pins (V_{IN} and LED) away from the switching node. Place the output capacitor, C2, next to the V_{IN} pin. Always use a ground plane under the switching regulator to minimize interplane coupling. Recommended component placement is shown in Figure 8.

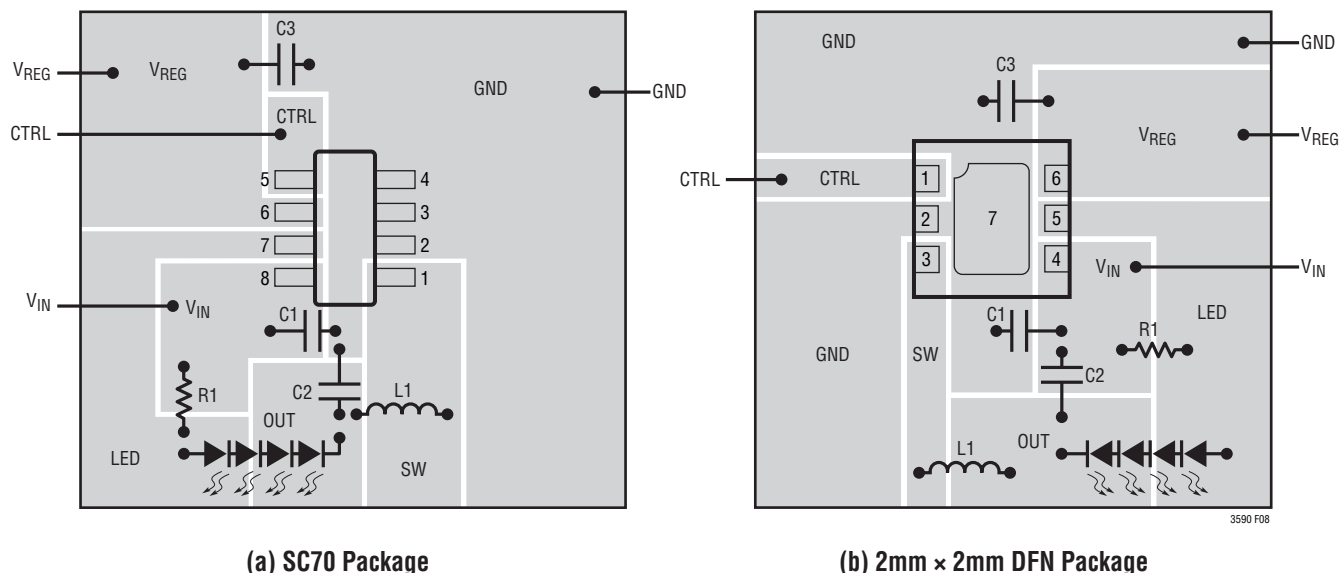
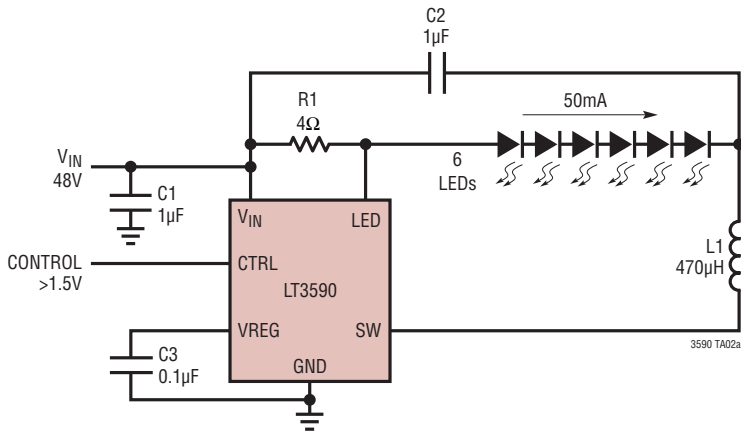

Figure 8. Recommended Component Placement

TYPICAL APPLICATIONS

48V Supply for 6 LED String, 50mA Current



L1: MURATA LQH32CN221K03

Conversion Efficiency

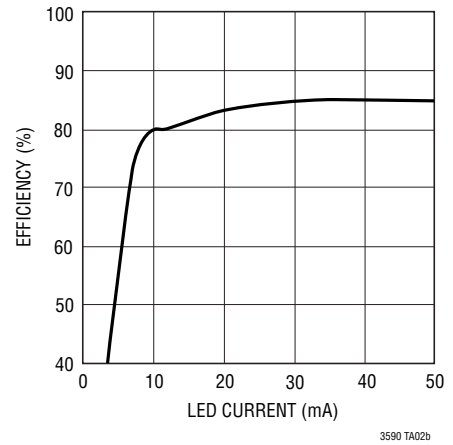

3590 TA02b

48V Supply for 5 LED String, 30mA Current

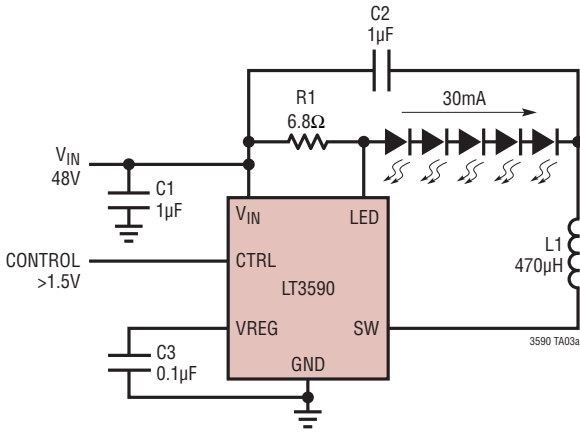

L1: MURATA LQH32CN-391

Conversion Efficiency

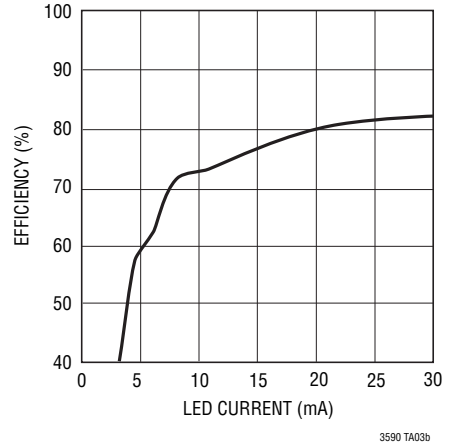

3590 TA03b

24V Supply for a 5 LED String, 30mA Current

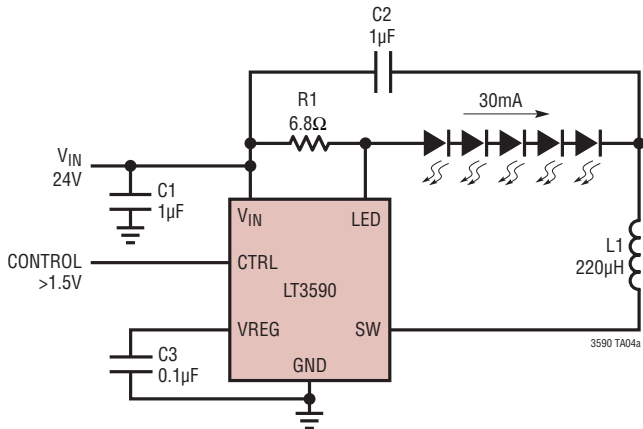

L1: MURATA LQH32CN-221

Conversion Efficiency

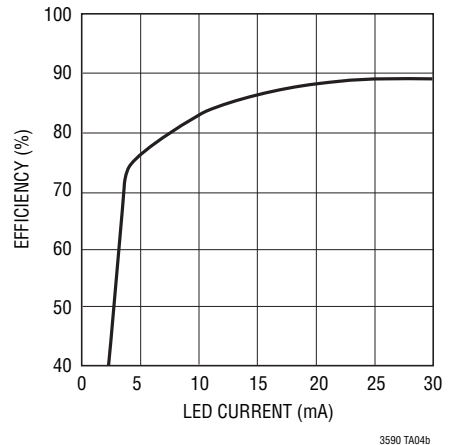

3590 TA04b

TYPICAL APPLICATIONS

12V or 24V Supply for a Single LED, 50mA Current

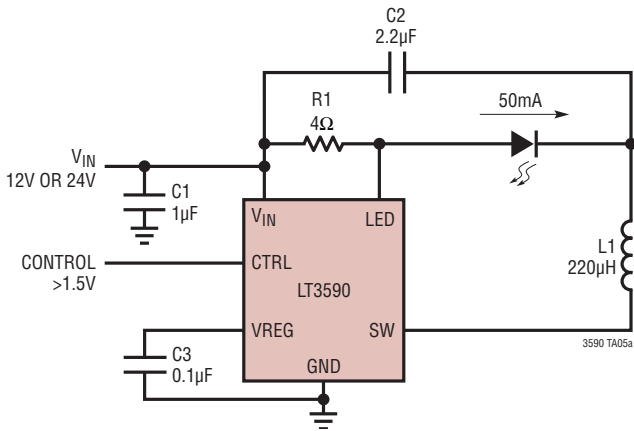

Conversion Efficiency

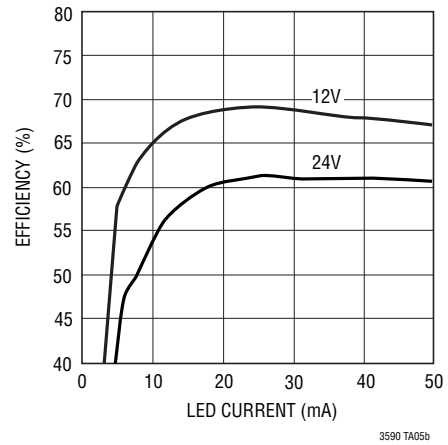

48V Supply for Two Strings of 10 LEDs, 25mA Current

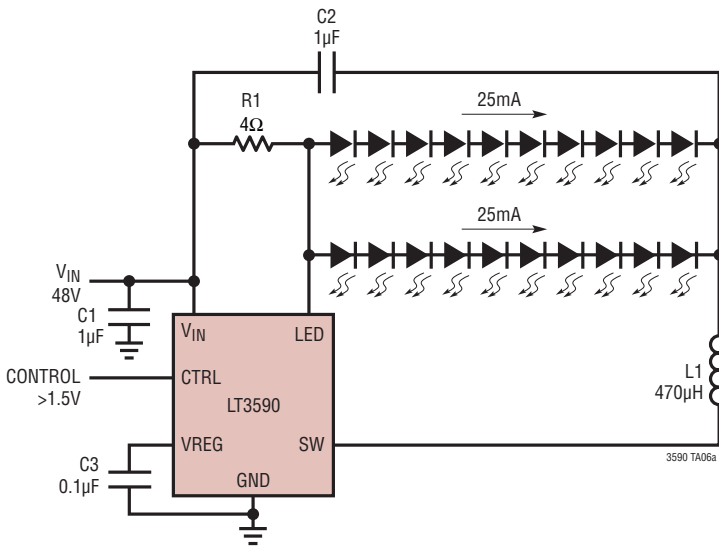

Conversion Efficiency

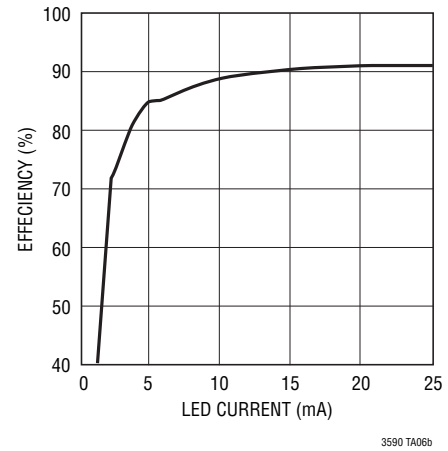

12V Supply for a 3 LED String, 50mA Current

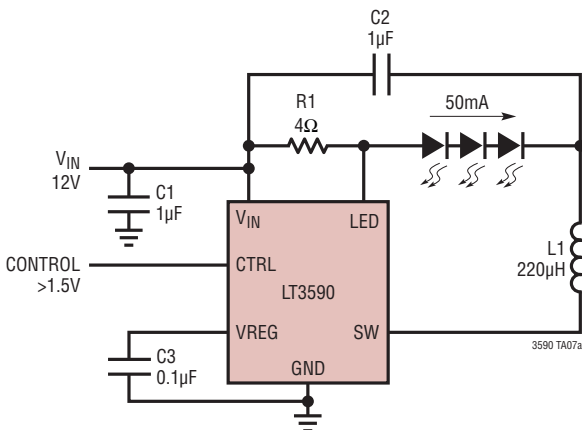

Conversion Efficiency

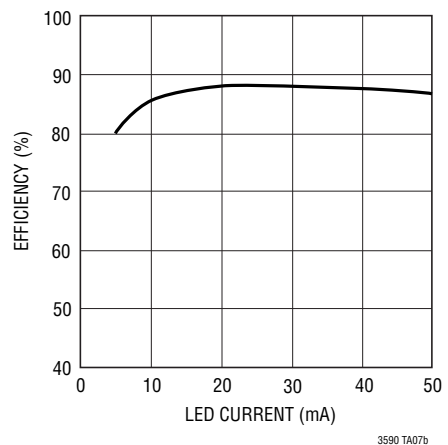

L1: MURATA LQH32CN-221

3590 TA07b

PACKAGE DESCRIPTION

DC Package
6-Lead Plastic DFN (2mm × 2mm)
 (Reference LTC DWG # 05-08-1703)

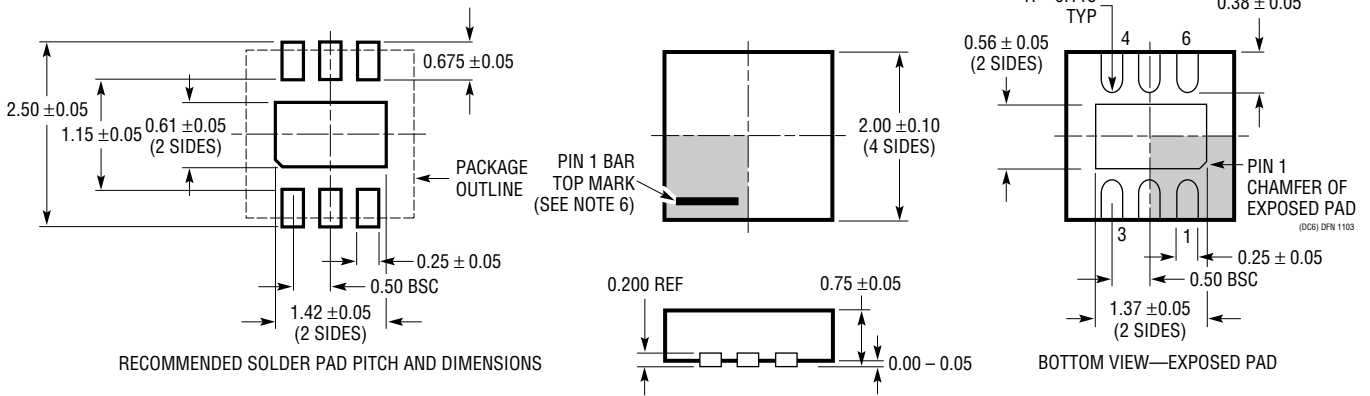

- NOTE:
1. DRAWING TO BE MADE A JEDEC PACKAGE OUTLINE M0-229 VARIATION OF (WCCD-2)
 2. DRAWING NOT TO SCALE
 3. ALL DIMENSIONS ARE IN MILLIMETERS
 4. DIMENSIONS OF EXPOSED PAD ON BOTTOM OF PACKAGE DO NOT INCLUDE MOLD FLASH. MOLD FLASH, IF PRESENT, SHALL NOT EXCEED 0.15mm ON ANY SIDE
 5. EXPOSED PAD SHALL BE SOLDER PLATED
 6. SHADED AREA IS ONLY A REFERENCE FOR PIN 1 LOCATION ON THE TOP AND BOTTOM OF PACKAGE

PACKAGE DESCRIPTION

SC8 Package 8-Lead Plastic SC70 (Reference LTC DWG # 05-08-1639 Rev 0)

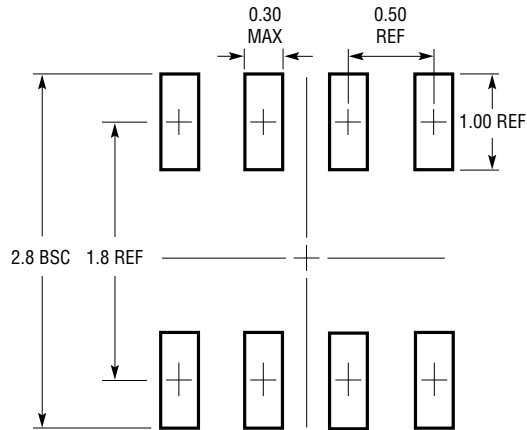

RECOMMENDED SOLDER PAD LAYOUT
PER IPC CALCULATOR

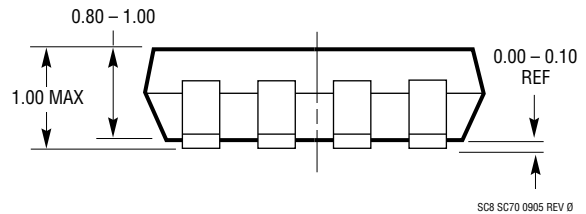
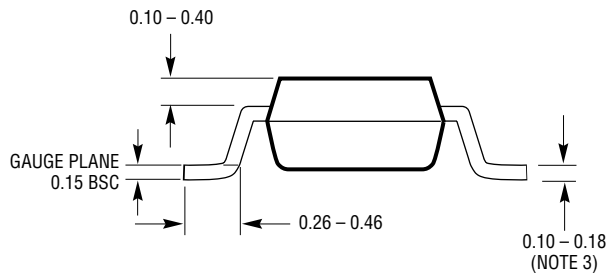
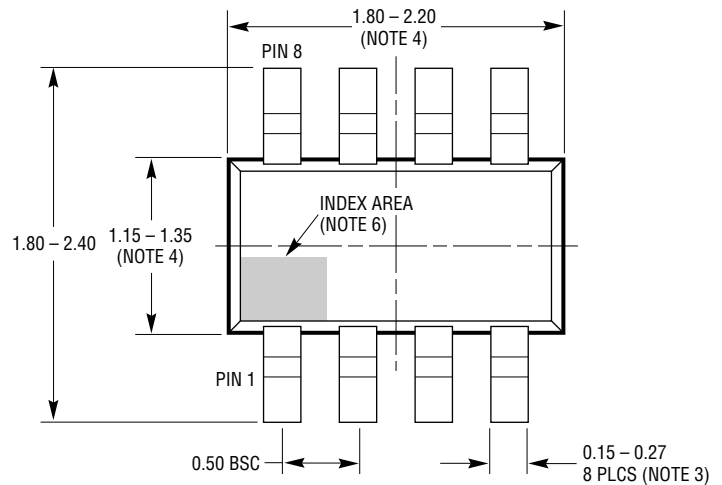

NOTE:

1. DIMENSIONS ARE IN MILLIMETERS
2. DRAWING NOT TO SCALE
3. DIMENSIONS ARE INCLUSIVE OF PLATING
4. DIMENSIONS ARE EXCLUSIVE OF MOLD FLASH AND METAL BURR

5. MOLD FLASH SHALL NOT EXCEED 0.254mm
6. DETAILS OF THE PIN 1 IDENTIFIER ARE OPTIONAL, BUT MUST BE LOCATED WITHIN THE INDEX AREA
7. EIAJ PACKAGE REFERENCE IS EIAJ SC-70 AND JEDEC MO-203 VARIATION BA

TYPICAL APPLICATION

24V Supply for 6 LED String, 50mA Current

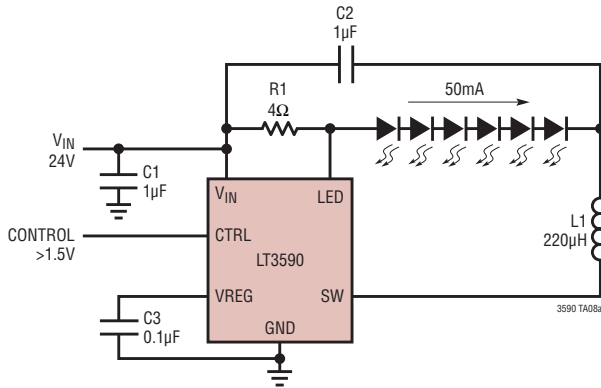

L1: MURATA LQH32CN-221

Conversion Efficiency

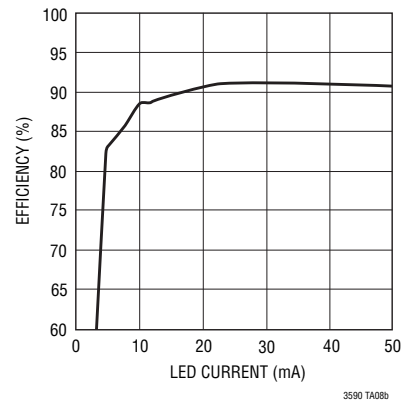

3590 TA08b

RELATED PARTS

PART NUMBER	DESCRIPTION	COMMENTS
LT1932	Constant Current, 1.2MHz, High Efficiency White LED Boost Regulator	V_{IN} : 1.0V to 10.0V, $V_{OUT(MAX)}$ = 34V, Dimming Analog/PWM, I_{SD} < 1µA, ThinSOT™ Package
LT3003	Three Channel LED Ballaster with PWM Dimming	V_{IN} : 3.0V to 48.0V, Dimming 3,000:1 True Color PWM™, I_{SD} < 5µA, MSOP-10 Package
LT3465/A	Constant Current, 1.2/2.7MHz, High Efficiency White LED Boost Regulator with Integrated Schottky Diode	V_{IN} : 2.7V to 16.0V, $V_{OUT(MAX)}$ = 34V, Dimming Analog/PWM, I_{SD} < 1µA, ThinSOT Package
LT3466/-1	Dual Constant Current, 2MHz, High Efficiency White LED Boost Regulator with Integrated Schottky Diode	V_{IN} : 2.7V to 24.0V, $V_{OUT(MAX)}$ = 40V, Dimming 5mA, I_{SD} < 16µA, 3mm × 3mm DFN-10
LT3474	36V, 1A (I_{LED}), 2MHz, Step-Down LED Driver	V_{IN} : 4.0V to 36V, $V_{OUT(MAX)}$ = 13.5V, Dimming 400:1 True Color PWM, I_{SD} < 1µA, TSSOP16E Package
LT3475	Dual 1.5A(I_{LED}), 36V, 2MHz, Step-Down LED Driver	V_{IN} : 4.0V to 36V, $V_{OUT(MAX)}$ = 13.5V, Dimming 3,000:1 True Color PWM, I_{SD} < 1µA, TSSOP20E Package
LT3476	Quad Output 1.5A, 2MHz High Current LED Driver with 1,000:1 Dimming	V_{IN} : 2.8V to 16.0V, $V_{OUT(MAX)}$ = 36.0V, Dimming 1,000:1 True Color PWM, I_{SD} < 10µA, 5mm × 7mm QFN-10
LT3478/-1	4.5A, 2MHz High Current LED Driver with 3,000:1 Dimming	V_{IN} : 2.8V to 36.0V, $V_{OUT(MAX)}$ = 40.0V, Dimming 1,000:1 True Color PWM, I_{SD} < 10µA, 5mm × 7mm QFN-10
LT3486	Dual 1.3A, 2MHz High Current LED Driver	V_{IN} : 2.5V to 24.0V, $V_{OUT(MAX)}$ = 36.0V, Dimming 1,000:1 True Color PWM, I_{SD} < 1µA, 5mm × 3mm DFN, TSSOP-16E Package
LT3491	Constant Current, 2.3MHz, High Efficiency White LED Boost Regulator with Integrated Schottky Diode	V_{IN} : 2.5V to 12.0V, $V_{OUT(MAX)}$ = 27V, Dimming 300:1 True Color PWM, I_{SD} < 8µA, 2mm × 2mm DFN-6, SC70 Package
LT3496	Triple Output 750mA, 2.1 MHz High Current LED Driver with 3,000:1 Dimming	V_{IN} : 3.0V to 30.0V, $V_{OUT(MAX)}$ = 40.0, Dimming 3,000:1 True Color PWM, I_{SD} < 1µA, 4mm × 5mm QFN-28
LT3497	Dual 2.3MHz, Full Function LED Driver with Integrated Schottkys and 250:1 True Color PWM Dimming	V_{IN} : 2.5V to 10.0V, $V_{OUT(MAX)}$ = 32, Dimming 250:1 True Color PWM, I_{SD} < 12µA, 2mm × 3mm DFN-10
LT3498	20mA LED Driver and OLED Driver Integrated Schottkys	V_{IN} : 2.5 to 12.0V, $V_{OUT(MAX)}$ = 32, Dimming Analog/PWM, I_{SD} < 8.5µA, 2mm × 3mm DFN-12
LT3517	1.3A, 2.5MHz High Current LED Driver with 3,000:1 Dimming	V_{IN} : 3.0V to 30.0V, Dimming 3,000:1 True Color PWM, I_{SD} < 1µA, 4mm × 4mm QFN-16
LT3518	2.3A, 2.5MHz High Current LED Driver with 3,000:1 Dimming	V_{IN} : 3.0V to 30.0V, Dimming 3,000:1 True Color PWM, I_{SD} < 1µA, 4mm × 4mm QFN-16
LT3591	Constant Current, 1MHz, High Efficiency White LED Boost Regulator with Integrated Schottky Diode and 80:1 True Color PWM Dimming	V_{IN} : 2.5V to 12.0V, $V_{OUT(MAX)}$ = 40, Dimming 80:1 True Color PWM, I_{SD} < 9µA, 2mm × 3mm DFN-8

ThinSOT and True Color PWM are trademarks of Linear Technology Corporation.

3590f

Looking for pricing, stock, or lifecycle information?

Click below to explore more details on WIN SOURCE:

 [View LT3590EDC#TRMPBF on WIN SOURCE](#)

 [Linear Technology](#) Information

Optimize Your Supply Chain with WIN SOURCE Solutions

-  Global Sourcing Solution
-  Obsolete Management
-  Cost Control Management
-  Shortage Management
-  Alternative Solution
-  Excess Inventory Management