



**THE DATASHEET OF  
LT1880IS5#TRPBF**



# SOT-23, Rail-to-Rail Output, Picoamp Input Current Precision Op Amp

## FEATURES

- **Offset Voltage: 150 $\mu$ V Max**
- **Input Bias Current: 900pA Max**
- **Offset Voltage Drift: 1.2 $\mu$ V/ $^{\circ}$ C Max**
- **Rail-to-Rail Output Swing**
- Operates with Single or Split Supplies
- Open-Loop Voltage Gain: 1 Million Min
- 1.2mA Supply Current
- Slew Rate: 0.4V/ $\mu$ s
- Gain Bandwidth: 1.1MHz
- Low Noise: 13nV/ $\sqrt{\text{Hz}}$  at 1kHz
- Low Profile (1mm) ThinSOT™ Package

## APPLICATIONS

- Thermocouple Amplifiers
- Bridge Transducer Conditioners
- Instrumentation Amplifiers
- Battery-Powered Systems
- Photocurrent Amplifiers

## DESCRIPTION

The LT<sup>®</sup>1880 op amp brings high accuracy input performance and rail-to-rail output swing to the SOT-23 package. Input offset voltage is trimmed to less than 150 $\mu$ V and the low drift maintains this accuracy over the operating temperature range. Input bias current is an ultralow 900pA maximum.

The amplifier works on any total power supply voltage between 2.7V and 36V (fully specified from 5V to  $\pm$ 15V). Output voltage swings to within 55mV of the negative supply and 250mV of the positive supply, which makes the amplifier a good choice for low voltage single supply operation.

Slew rates of 0.4V/ $\mu$ s with a supply current of 1.2mA give superior response and settling time performance in a low power precision amplifier.

The LT1880 is available in a 5-lead SOT-23 package.

LT, LT, LTC, LTM, Linear Technology and the Linear logo are registered trademarks of Linear Technology Corporation. ThinSOT is a trademark of Linear Technology Corporation. All other trademarks are the property of their respective owners.

## TYPICAL APPLICATION

**Precision Photodiode Amplifier**

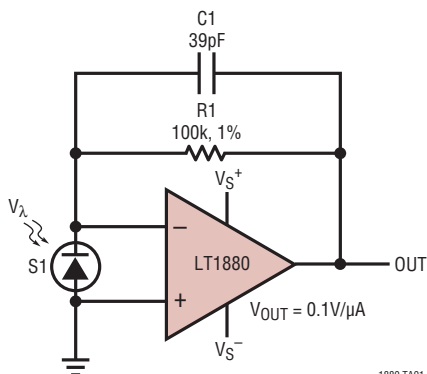

320 $\mu$ V OUTPUT OFFSET, WORST CASE OVER 0 $^{\circ}$ C TO 70 $^{\circ}$ C  
 60kHz BANDWIDTH  
 5.8 $\mu$ s RISE TIME, 10% TO 90%, 100mV OUTPUT STEP  
 52 $\mu$ V<sub>RMS</sub> OUTPUT NOISE, MEASURED ON A 100kHz BW  
 $V_S = \pm 1.5V$  TO  $\pm 18V$   
 S1: SIEMENS INFINEON BPW21 PHOTODIODE ( $\sim 580\text{pF}$ )

**Distribution of Input Offset Voltage**

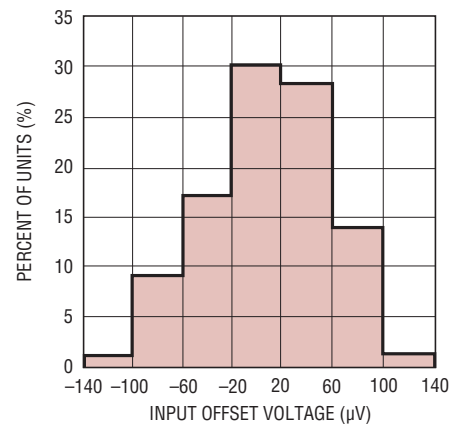

1880 TA01b

# LT1880

## ABSOLUTE MAXIMUM RATINGS

(Note 1)

Supply Voltage ( $V^+$ to $V^-$ )	40V
Differential Input Voltage (Note 2)	$\pm 10V$
Input Voltage	$V^+$ to $V^-$
Input Current (Note 2)	$\pm 10mA$
Output Short-Circuit Duration (Note 3)	Indefinite
Operating Temperature Range (Note 4)	$-40^\circ C$ to $85^\circ C$
Specified Temperature Range (Note 5)	$-40^\circ C$ to $85^\circ C$
Maximum Junction Temperature	$150^\circ C$
Storage Temperature Range	$-65^\circ C$ to $150^\circ C$
Lead Temperature (Soldering, 10 sec)	$300^\circ C$

## PIN CONFIGURATION

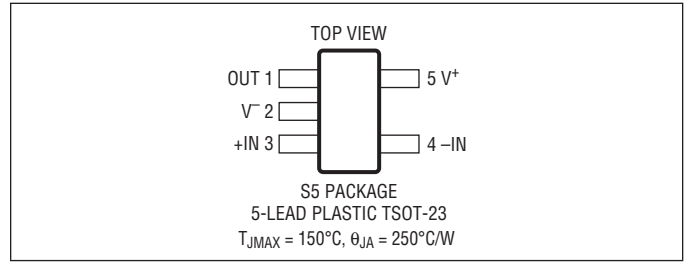

## ORDER INFORMATION

LEAD FREE FINISH	TAPE AND REEL	PART MARKING	PACKAGE DESCRIPTION	SPECIFIED TEMPERATURE RANGE
LT1880CS5#PBF	LT1880CS5#TRPBF	LTUM	5-Lead Plastic TSOT-23	$0^\circ C$ to $70^\circ C$
LT1880IS5#PBF	LT1880IS5#TRPBF	LTVW	5-Lead Plastic TSOT-23	$-40^\circ C$ to $85^\circ C$

Consult LTC Marketing for parts specified with wider operating temperature ranges.

Consult LTC Marketing for information on non-standard lead based finish parts.

For more information on lead free part marking, go to: <http://www.linear.com/leadfree/>

For more information on tape and reel specifications, go to: <http://www.linear.com/tapeandree/>

## ELECTRICAL CHARACTERISTICS

The ● denotes the specifications which apply over the full operating temperature range, otherwise specifications are at  $T_A = 25^\circ C$ .  $V_S = 5V$ ,  $0V$ ;  $V_{CM} = 2.5V$  unless otherwise noted. (Note 5)

SYMBOL	PARAMETER	CONDITIONS	MIN	TYP	MAX	UNITS
$V_{OS}$	Input Offset Voltage	$0^\circ C < T_A < 70^\circ C$	●	40	150	$\mu V$
		$-40^\circ C < T_A < 85^\circ C$	●		200	$\mu V$
					250	$\mu V$
	Input Offset Voltage Drift (Note 6)	$0^\circ C < T_A < 70^\circ C$	●	0.3	1.2	$\mu V/^\circ C$
		$-40^\circ C < T_A < 85^\circ C$	●	0.3	1.2	$\mu V/^\circ C$
$I_{OS}$	Input Offset Current	$0^\circ C < T_A < 70^\circ C$	●	150	900	pA
		$-40^\circ C < T_A < 85^\circ C$	●		1200	pA
					1400	pA
$I_B$	Input Bias Current	$0^\circ C < T_A < 70^\circ C$	●	150	900	pA
		$-40^\circ C < T_A < 85^\circ C$	●		1200	pA
					1500	pA
	Input Noise Voltage	0.1Hz to 10Hz		0.5		$\mu V_{p-p}$
$e_n$	Input Noise Voltage Density	$f = 1kHz$		13		$nV/\sqrt{Hz}$
$i_n$	Input Noise Current Density	$f = 1kHz$		0.07		$pA/\sqrt{Hz}$
$R_{IN}$	Input Resistance	Differential Common Mode, $V_{CM} = 1V$ to $3.8V$		380		$M\Omega$
				210		$G\Omega$
$C_{IN}$	Input Capacitance			3.7		pF
$V_{CM}$	Input Voltage Range		●	$(V^- + 1.0)$	$(V^+ - 1.2)$	V

1880fa

**ELECTRICAL CHARACTERISTICS** The ● denotes the specifications which apply over the full operating temperature range, otherwise specifications are at  $T_A = 25^\circ\text{C}$ .  $V_S = 5\text{V}$ ,  $0\text{V}$ ;  $V_{CM} = 2.5\text{V}$  unless otherwise noted. (Note 5)

SYMBOL	PARAMETER	CONDITIONS	MIN	TYP	MAX	UNITS
CMRR	Common Mode Rejection Ratio	$1\text{V} < V_{CM} < 3.8\text{V}$	● 116	135		dB
PSRR	Power Supply Rejection Ratio	$V^- = 0\text{V}$ , $V_{CM} = 1.5\text{V}$ ; $2.7\text{V} < V^+ < 32\text{V}$	● 110	135		dB
	Minimum Operating Supply Voltage		●	2.4	2.7	V
$A_{VOL}$	Large Signal Voltage Gain	$R_L = 10\text{k}$ ; $1\text{V} < V_{OUT} < 4\text{V}$	● 500	1600		V/mV
		$R_L = 2\text{k}$ ; $1\text{V} < V_{OUT} < 4\text{V}$	● 400	800		V/mV
		$R_L = 1\text{k}$ ; $1\text{V} < V_{OUT} < 4\text{V}$	● 300	400		V/mV
			● 300	400		V/mV
			● 250			V/mV
$V_{OL}$	Output Voltage Swing Low	No Load	●	20	55	mV
		$I_{SINK} = 100\mu\text{A}$	●	35	65	mV
		$I_{SINK} = 1\text{mA}$	●	130	200	mV
$V_{OH}$	Output Voltage Swing High (Referred to $V^+$ )	$V^+ = 5\text{V}$ ; No Load	●	130	250	mV
		$V^+ = 5\text{V}$ ; $I_{SOURCE} = 100\mu\text{A}$	●	150	270	mV
		$V^+ = 5\text{V}$ ; $I_{SOURCE} = 1\text{mA}$	●	220	380	mV
$I_S$	Supply Current per Amplifier	$V^+ = 3\text{V}$	●	1.2	1.8	mA
					2.2	mA
		$V^+ = 5\text{V}$	●	1.2	1.9	mA
				2.3	mA	
		$V^+ = 12\text{V}$	●	1.35	2	mA
				2.4	mA	
$I_{SC}$	Short-Circuit Current	$V_{OUT}$ Short to GND	● 10	18		mA
		$V_{OUT}$ Short to $V^+$	● 10	20		mA
GBW	Gain-Bandwidth Product	$f = 20\text{kHz}$	0.8	1.1		MHz
$t_S$	Settling Time	0.01%, $V_{OUT} = 1.5\text{V}$ to $3.5\text{V}$ $A_V = -1$ , $R_L = 2\text{k}$		10		$\mu\text{s}$
FPBW	Full Power Bandwidth (Note 7)	$V_{OUT} = 4V_{P-P}$		32		kHz
THD	Total Harmonic Distortion and Noise	$V_O = 2V_{P-P}$ , $A_V = -1$ , $f = 1\text{kHz}$ , $R_f = 1\text{k}$ , $BW = 22\text{kHz}$		0.002		%
		$V_O = 2V_{P-P}$ , $A_V = 1$ , $f = 1\text{kHz}$ , $R_L = 10\text{k}$ , $BW = 22\text{kHz}$		0.0008		%
$SR^+$	Slew Rate Positive	$A_V = -1$	● 0.25	0.4		V/ $\mu\text{s}$
			● 0.2			V/ $\mu\text{s}$
$SR^-$	Slew Rate Negative	$A_V = -1$	● 0.25	0.55		V/ $\mu\text{s}$
			● 0.25			V/ $\mu\text{s}$

The ● denotes the specifications which apply over the full operating temperature range, otherwise specifications are at  $T_A = 25^\circ\text{C}$ .  $V_S = \pm 15\text{V}$ ,  $V_{CM} = 0\text{V}$  unless otherwise noted. (Note 5)

SYMBOL	PARAMETER	CONDITIONS	MIN	TYP	MAX	UNITS
$V_{OS}$	Input Offset Voltage	$0^\circ\text{C} < T_A < 70^\circ\text{C}$	●	40	150	$\mu\text{V}$
		$-40^\circ\text{C} < T_A < 85^\circ\text{C}$	●		200	$\mu\text{V}$
						250
	Input Offset Voltage Drift (Note 6)	$0^\circ\text{C} < T_A < 70^\circ\text{C}$	●	0.3	1.2	$\mu\text{V}/^\circ\text{C}$
		$-40^\circ\text{C} < T_A < 85^\circ\text{C}$	●	0.3	1.2	$\mu\text{V}/^\circ\text{C}$
$I_{OS}$	Input Offset Current	$0^\circ\text{C} < T_A < 70^\circ\text{C}$	●	150	900	pA
		$-40^\circ\text{C} < T_A < 85^\circ\text{C}$	●		1200	pA
						1400
$I_B$	Input Bias Current	$0^\circ\text{C} < T_A < 70^\circ\text{C}$	●	150	900	pA
		$-40^\circ\text{C} < T_A < 85^\circ\text{C}$	●		1200	pA
						1500
	Input Noise Voltage	0.1Hz to 10Hz		0.5		$\mu\text{V}/\text{p-p}$

## ELECTRICAL CHARACTERISTICS

The ● denotes the specifications which apply over the full operating temperature range, otherwise specifications are at  $T_A = 25^\circ\text{C}$ .  $V_S = \pm 15\text{V}$ ;  $V_{CM} = 0\text{V}$  unless otherwise noted. (Note 5)

SYMBOL	PARAMETER	CONDITIONS	MIN	TYP	MAX	UNITS
$e_n$	Input Noise Voltage Density	$f = 1\text{kHz}$		13		$\text{nV}/\sqrt{\text{Hz}}$
$i_n$	Input Noise Current Density	$f = 1\text{kHz}$		0.07		$\text{pA}/\sqrt{\text{Hz}}$
$R_{IN}$	Input Resistance	Differential Common Mode, $V_{CM} = -13.5\text{V}$ to $13.5\text{V}$		380 190		$\text{M}\Omega$ $\text{G}\Omega$
$C_{IN}$	Input Capacitance			3.7		$\text{pF}$
$V_{CM}$	Input Voltage Range		● $-13.5$		$13.5$	$\text{V}$
CMRR	Common Mode Rejection Ratio	$-13.5\text{V} < V_{CM} < 13.5\text{V}$	● 118	135		$\text{dB}$
+PSRR	Positive Power Supply Rejection Ratio	$V^- = -15\text{V}$ , $V_{CM} = 0\text{V}$ ; $1.5\text{V} < V^+ < 18\text{V}$	● 110	135		$\text{dB}$
-PSRR	Negative Power Supply Rejection Ratio	$V^+ = 15\text{V}$ , $V_{CM} = 0\text{V}$ ; $-1.5\text{V} < V^- < -18\text{V}$	● 110	135		$\text{dB}$
	Minimum Operating Supply Voltage		●	$\pm 1.2$	$\pm 1.35$	$\text{V}$
$A_{VOL}$	Large Signal Voltage Gain	$R_L = 10\text{k}$ ; $-13.5\text{V} < V_{OUT} < 13.5\text{V}$ $R_L = 2\text{k}$ ; $-13.5\text{V} < V_{OUT} < 13.5\text{V}$	● 1000 ● 700 ● 500 ● 300	1600  1000		$\text{V}/\text{mV}$ $\text{V}/\text{mV}$ $\text{V}/\text{mV}$ $\text{V}/\text{mV}$
$V_{OL}$	Output Voltage Swing Low (Referred to $V_{EE}$ )	No Load $I_{SINK} = 100\mu\text{A}$ $I_{SINK} = 1\text{mA}$	● 25 ● 35 ● 130	65 75 200		$\text{mV}$ $\text{mV}$ $\text{mV}$
$V_{OH}$	Output Voltage Swing High (Referred to $V_{CC}$ )	No Load $I_{SINK} = 100\mu\text{A}$ $I_{SINK} = 1\text{mA}$	● 185 ● 195 ● 270	350 370 450		$\text{mV}$ $\text{mV}$ $\text{mV}$
$I_S$	Supply Current per Amplifier		● 1.5 ● 1.8	2.3 2.8		$\text{mA}$ $\text{mA}$
$I_{SC}$	Short-Circuit Current	$V_{OUT}$ Short to $V^-$ $V_{OUT}$ Short to $V^+$	● 10 ● 10	25 25 20 20		$\text{mA}$ $\text{mA}$ $\text{mA}$ $\text{mA}$
FPBW	Full Power Bandwidth (Note 7)	$V_{OUT} = 14\text{V}_{P-P}$		9		$\text{kHz}$
GBW	Gain Bandwidth Product	$f = 20\text{kHz}$	0.8	1.1		$\text{MHz}$
THD	Total Harmonic Distortion and Noise	$V_O = 25\text{V}_{P-P}$ , $A_V = -1$ , $f = 100\text{kHz}$ , $R_f = 10\text{k}$ , $\text{BW} = 22\text{kHz}$ $V_O = 25\text{V}_{P-P}$ , $A_V = 1$ , $f = 100\text{kHz}$ , $R_L = 10\text{k}$ , $\text{BW} = 22\text{kHz}$		0.00029 0.00029		% %
$SR^+$	Slew Rate Positive	$A_V = -1$	● 0.25 ● 0.2	0.4		$\text{V}/\mu\text{s}$ $\text{V}/\mu\text{s}$
$SR^-$	Slew Rate Negative	$A_V = -1$	● 0.25 ● 0.2	0.55		$\text{V}/\mu\text{s}$ $\text{V}/\mu\text{s}$

**Note 1:** Stresses beyond those listed under Absolute Maximum Ratings may cause permanent damage to the device. Exposure to any Absolute Maximum Rating condition for extended periods may affect device reliability and lifetime.

**Note 2:** The inputs are protected by back-to-back diodes. If the differential input voltage exceeds 10V, see Application Information, the input current should be limited to less than 10mA.

**Note 3:** A heat sink may be required to keep the junction temperature below absolute maximum ratings.

**Note 4:** The LT1880C and LT1880I are guaranteed functional over the operating temperature range of  $-40^\circ\text{C}$  to  $85^\circ\text{C}$ .

**Note 5:** The LT1880C is guaranteed to meet specified performance from  $0^\circ\text{C}$  to  $70^\circ\text{C}$  and is designed, characterized and expected to meet specified performance from  $-40^\circ\text{C}$  to  $85^\circ\text{C}$  but is not tested or QA sampled at these temperatures. The LT1880I is guaranteed to meet specified performance from  $-40^\circ\text{C}$  to  $85^\circ\text{C}$ .

**Note 6:** This parameter is not 100% tested.

**Note 7:** Full power bandwidth is calculated from the slew rate.

$$\text{FPBW} = \text{SR}/(2\pi V_P)$$

# TYPICAL PERFORMANCE CHARACTERISTICS

**Input Offset Voltage vs Temperature**

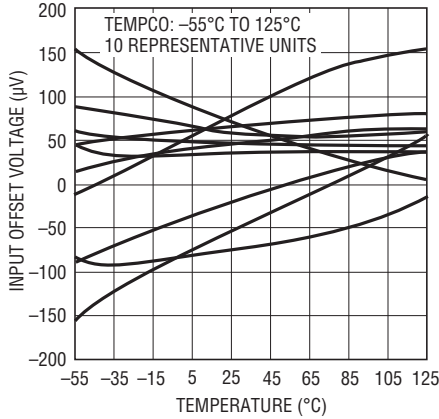

1880 G01

**Input Bias Current vs Common Mode Voltage**

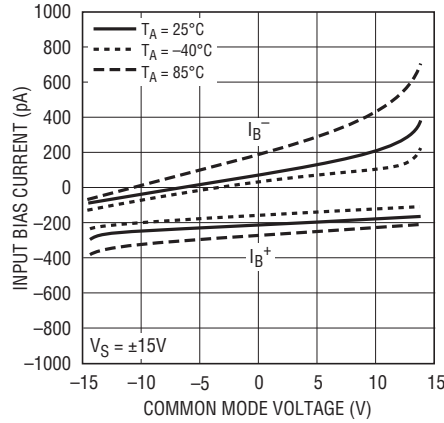

1880 G02

**Input Bias Current vs Common Mode Near VCC**

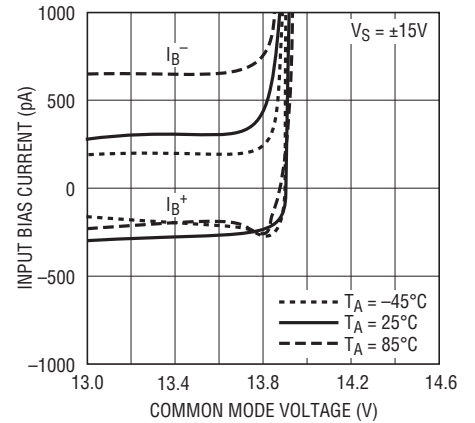

1880 G02A

**Input Bias Current vs Common Mode Near VEE**

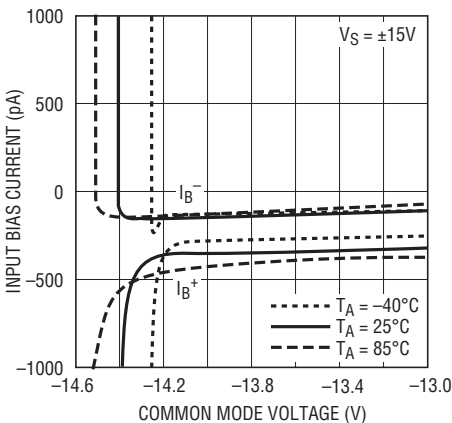

1880 G02B

**Input Bias Current vs Temperature**

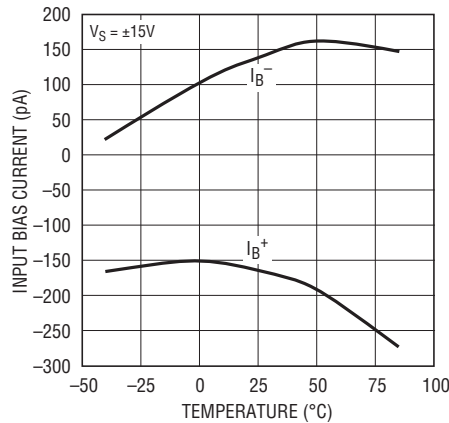

1880 G03

**Output Voltage Swing vs Load Current**

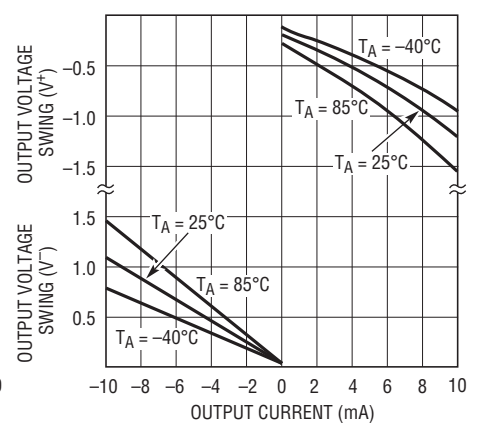

1880 G04

**Warm Up Drift**

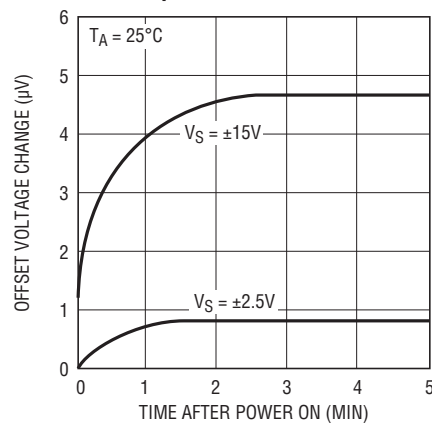

1880 G05

**en, in vs Frequency**

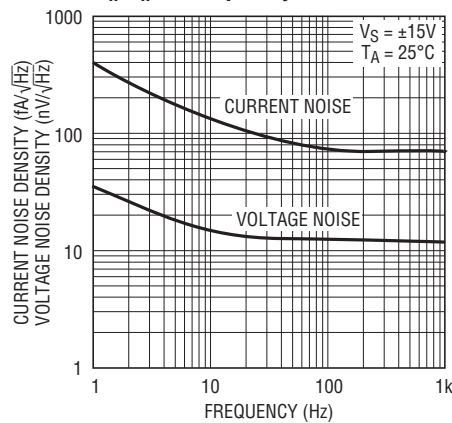

1880 G08

**0.1 to 10Hz Noise**

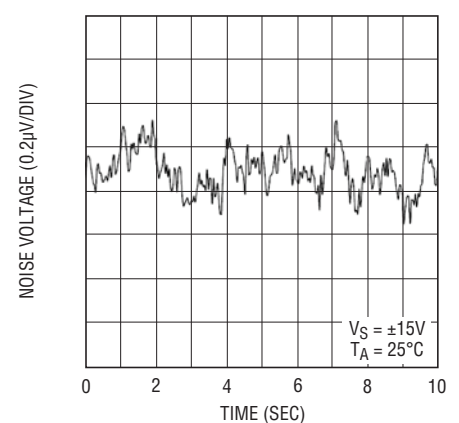

1880 G09a

## TYPICAL PERFORMANCE CHARACTERISTICS

0.01 to 1Hz Noise

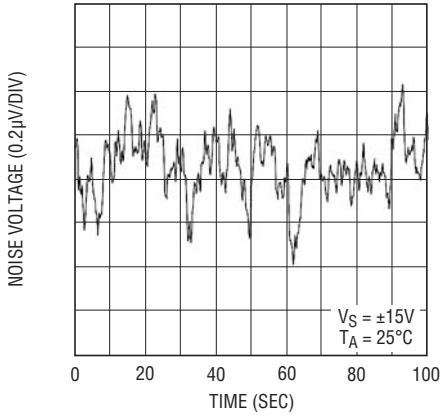

1880 G09b

Gain vs Frequency

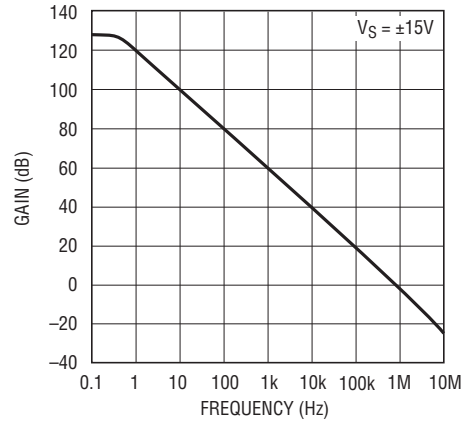

1880 G10

PSRR vs Frequency

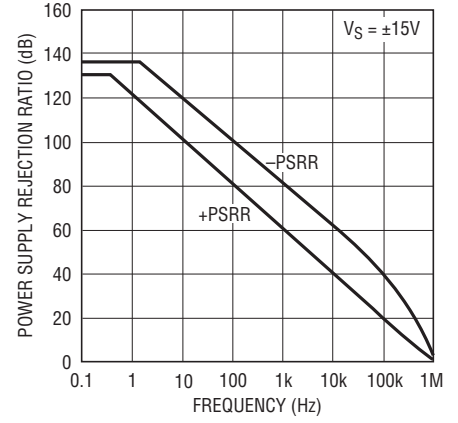

1880 G11

CMRR vs Frequency

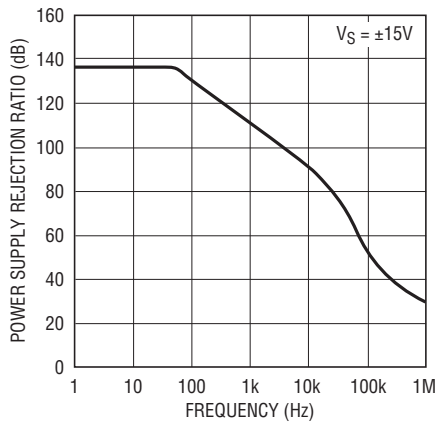

1880 G12

Gain and Phase vs Frequency

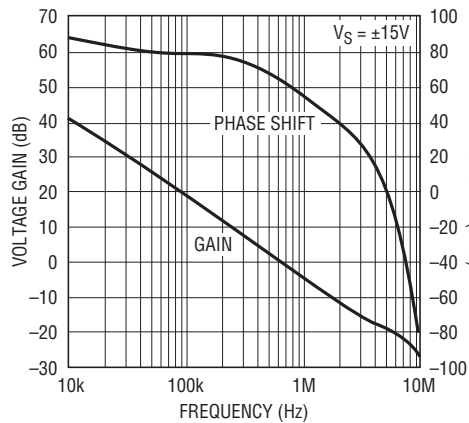

1880 G13

Settling Time vs Output Step

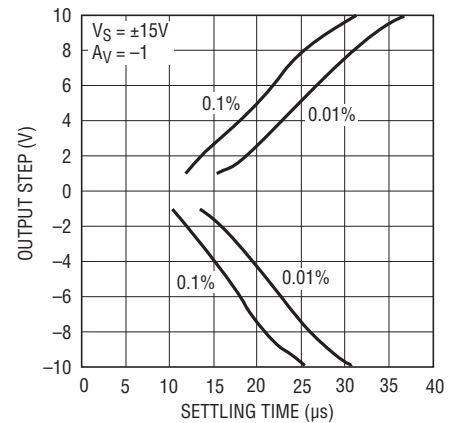

1880 G14

Settling Time vs Output Step

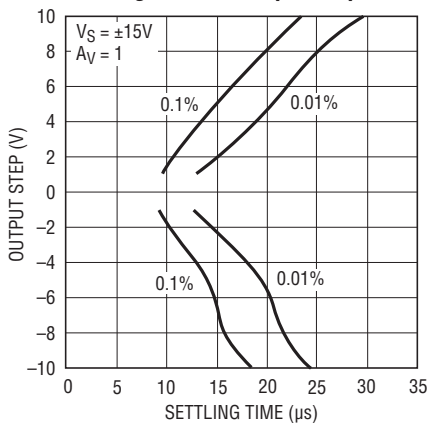

1880 G15

Slew Rate, Gain-Bandwidth Product and Phase Margin vs Temperature

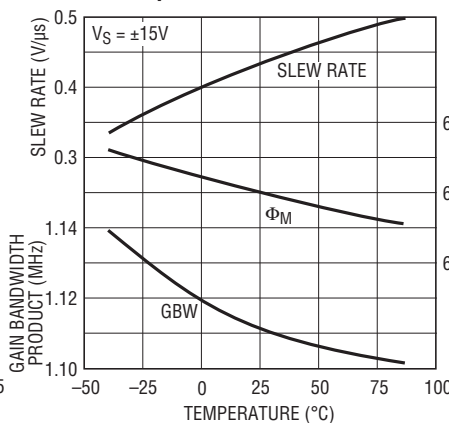

1880 G16

Slew Rate, Gain-Bandwidth Product and Phase Margin vs Power Supply

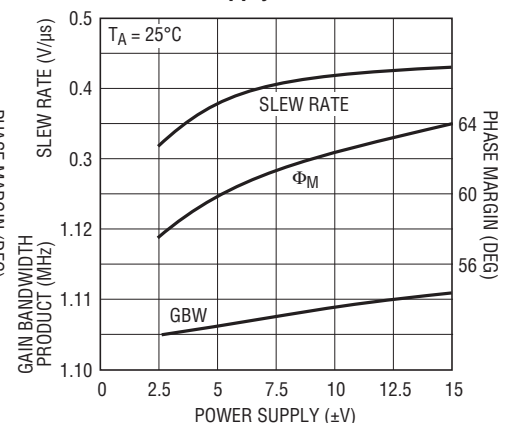

1880 G17

# TYPICAL PERFORMANCE CHARACTERISTICS

**Gain vs Frequency with  $C_{LOAD}$ ,  $A_V = -1$**



1880 G18

**Gain vs Frequency with  $C_{LOAD}$ ,  $A_V = 1$**

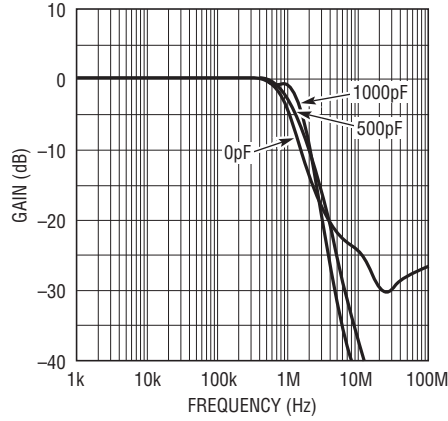

1880 G19

**Output Impedance vs Frequency**

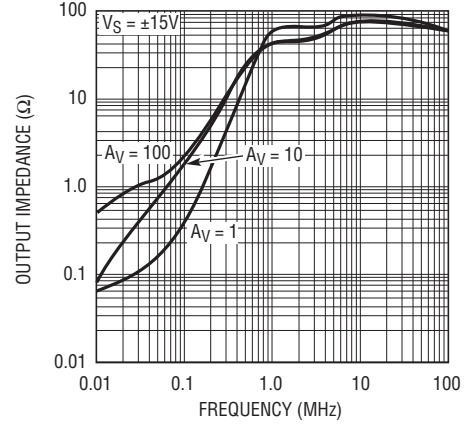

1880 G17A

**Total Harmonic Distortion + Noise vs Frequency**

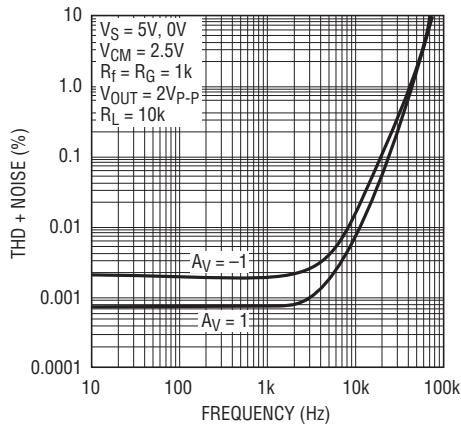

1880 G17B

**Small Signal Response**

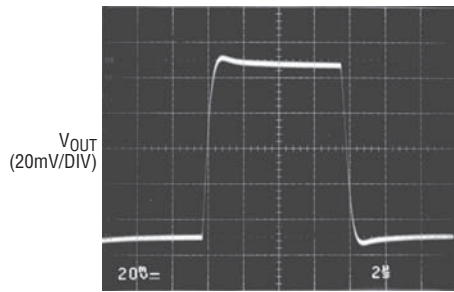

1880 G20

**Small Signal Response**

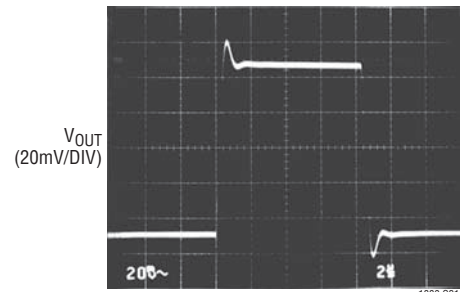

1880 G21

**Small Signal Response**

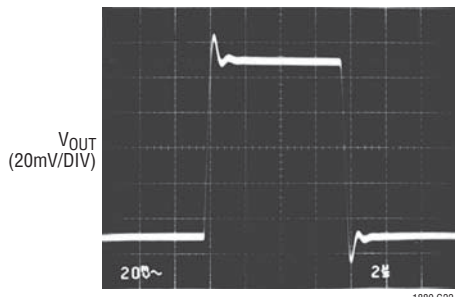

1880 G22

**Large Signal Response**

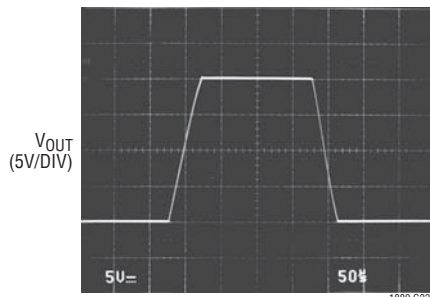

1880 G23

**Large Signal Response**

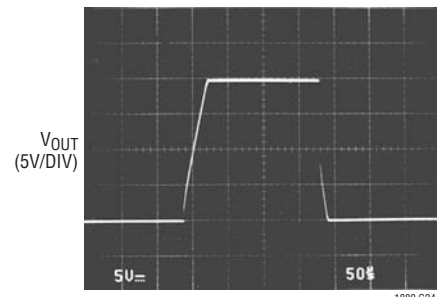

1880 G24

## APPLICATIONS INFORMATION

The LT1880 single op amp features exceptional input precision with rail-to-rail output swing. Slew rate and small signal bandwidth are superior to other amplifiers with comparable input precision. These characteristics make the LT1880 a convenient choice for precision low voltage systems and for improved AC performance in higher voltage precision systems. Obtaining beneficial advantage of the precision inherent in the amplifier depends upon proper applications circuit design and board layout.

### Preserving Input Precision

Preserving the input voltage accuracy of the LT1880 requires that the applications circuit and PC board layout do not introduce errors comparable to or greater than the 40 $\mu$ V offset. Temperature differentials across the input connections can generate thermocouple voltages of 10's of microvolts. PC board layouts should keep connections to the amplifier's input pins close together and away from heat dissipating components. Air currents across the board can also generate temperature differentials.

The extremely low input bias currents, 150pA, allow high accuracy to be maintained with high impedance sources and feedback networks. The LT1880's low input bias currents are obtained by using a cancellation circuit on-chip. This causes the resulting  $I_{BIAS^+}$  and  $I_{BIAS^-}$  to be uncorrelated, as implied by the  $I_{OS}$  specification being comparable to  $I_{BIAS}$ . The user should not try to balance the input resistances in each input lead, as is commonly recommended with most amplifiers. The impedance at either input should be kept as small as possible to minimize total circuit error.

PC board layout is important to insure that leakage currents do not corrupt the low  $I_{BIAS}$  of the amplifier. In high precision, high impedance circuits, the input pins should be surrounded by a guard ring of PC board interconnect, with the guard driven to the same common mode voltage as the amplifier inputs.

### Input Common Mode Range

The LT1880 output is able to swing nearly to each power supply rail, but the input stage is limited to operating between  $V^- + 1V$  and  $V^+ - 1.2V$ . Exceeding this common mode range will cause the gain to drop to zero, however no gain reversal will occur.

### Input Protection

The inverting and noninverting input pins of the LT1880 have limited on-chip protection. ESD protection is provided to prevent damage during handling. The input transistors have voltage clamping and limiting resistors to protect against input differentials up to 10V. Short transients above this level will also be tolerated. If the input pins can see a sustained differential voltage above 10V, external limiting resistors should be used to prevent damage to the amplifier. A 1k resistor in each input lead will provide protection against a 30V differential voltage.

### Capacitive Loads

The LT1880 can drive capacitive loads up to 600pF in unity gain. The capacitive load driving capability increases as the amplifier is used in higher gain configurations, see the graph labeled Capacitive Load Response. Capacitive load driving may be increased by decoupling the capacitance from the output with a small resistance.

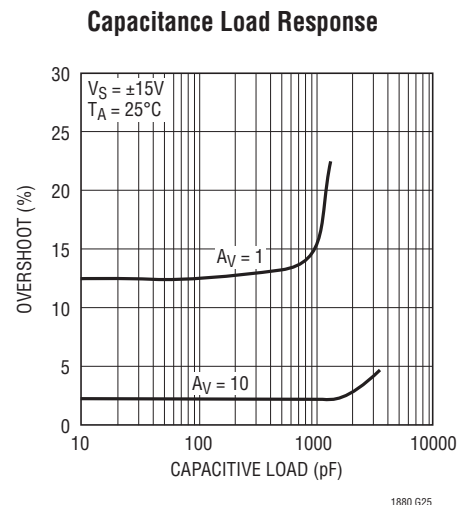

### Getting Rail-to-Rail Operation without Rail-to-Rail Inputs

The LT1880 does not have rail-to-rail inputs, but for most inverting applications and noninverting gain applications, this is largely inconsequential. Figure 1 shows the basic op amp configurations, what happens to the op amp inputs, and whether or not the op amp must have rail-to-rail inputs.

APPLICATIONS INFORMATION

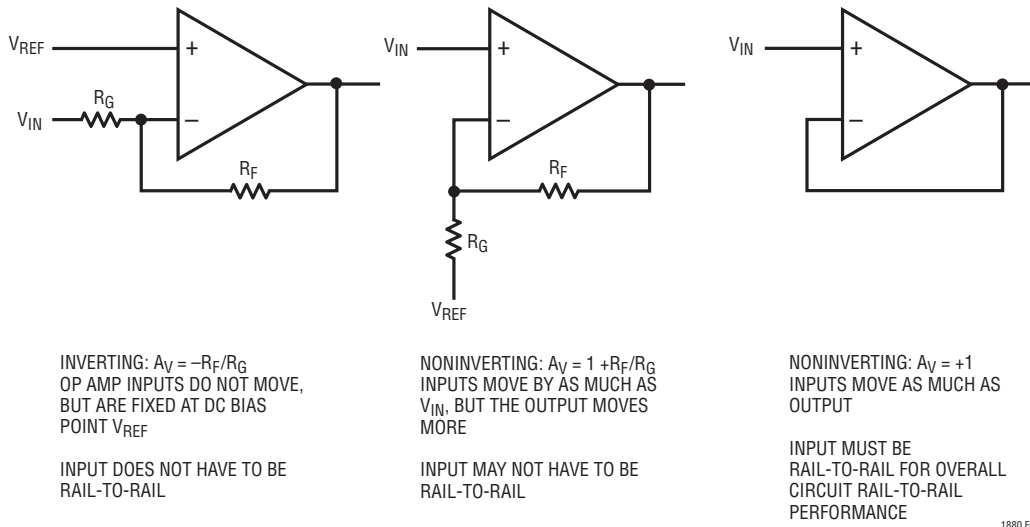

Figure 1. Some Op Amp Configurations Do Not Require Rail-to Rail Inputs to Achieve Rail-to-Rail Outputs

The circuit of Figure 2 shows an extreme example of the inverting case. The input voltage at the 1M resistor can swing  $\pm 13.5V$  and the LT1880 will output an inverted, divided-by-ten version of the input voltage. The input accuracy is limited by the resistors to 0.2%. Output referred, this error becomes 2.7mV. The 40 $\mu V$  input offset voltage contribution, plus the additional error due to input bias current times the  $\sim 100k$  effective source impedance, contribute only negligibly to error.

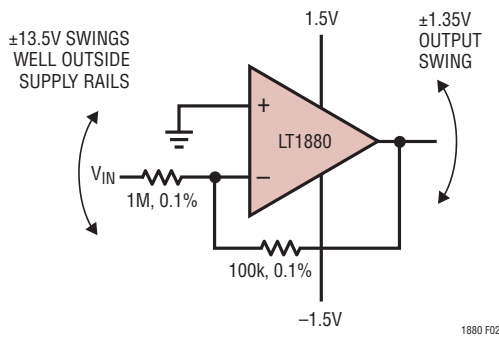

Figure 2. Extreme Inverting Case: Circuit Operates Properly with Input Voltage Swing Well Outside Op Amp Supply Rails.

Precision Photodiode Amplifier

Photodiode amplifiers usually employ JFET op amps because of their low bias current; however, when precision is required, JFET op amps are generally inadequate due to their relatively high input offset voltage and drift. The LT1880 provides a high degree of precision with very low bias current ( $I_B = 150pA$  typical) and is therefore applicable to this demanding task. Figure 3 shows an LT1880 configured as a transimpedance photodiode amplifier.

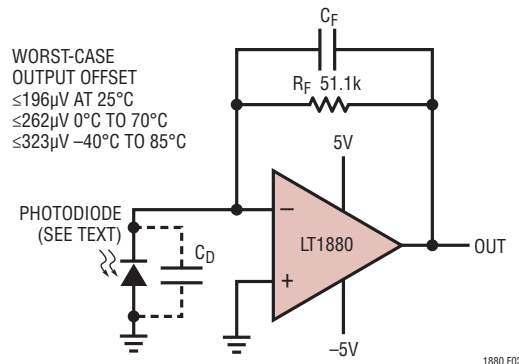

Figure 3. Precision Photodiode Amplifier

## APPLICATIONS INFORMATION

The transimpedance gain is set to 51.1k $\Omega$  by R<sub>F</sub>. The feedback capacitor, C<sub>F</sub>, may be as large as desired where response time is not an issue, or it may be selected for maximally flat response and highest possible bandwidth given a photodiode capacitance C<sub>D</sub>. Figure 4 shows a chart of C<sub>F</sub> and rise time versus C<sub>D</sub> for maximally flat response. Total output offset is below 262 $\mu$ V, worst-case, over temperature (0°C to 70°C). With a 5V output swing, this guarantees a minimum 86dB dynamic range over temperature (0°C to 70°C), and a full-scale photodiode current of 98 $\mu$ A.

### Single-Supply Current Source for Platinum RTD

The precision, low bias current input stage of the LT1880 makes it ideal for precision integrators and current sources. Figure 5 shows the LT1880 providing a simple precision current source for a remote 1k $\Omega$  RTD on a 4-wire

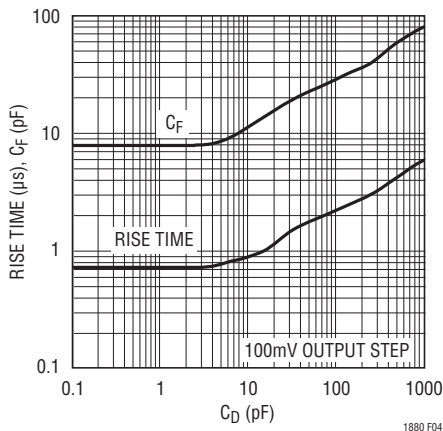
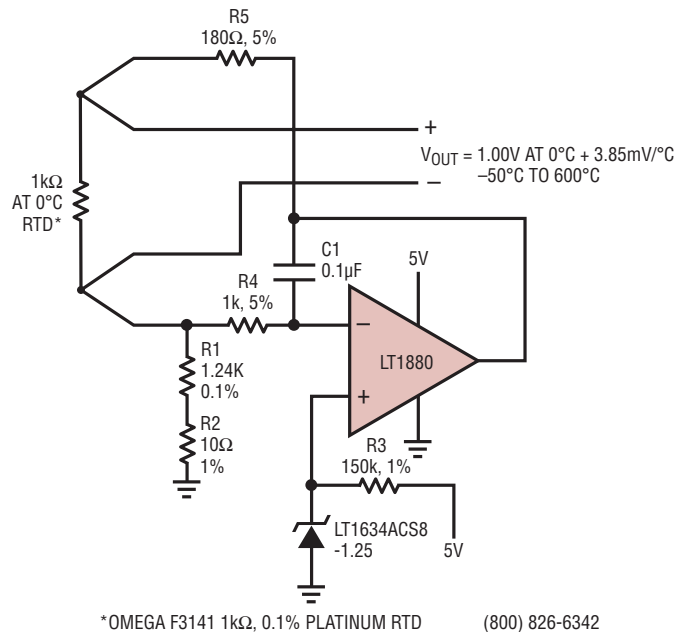

Figure 4. Feedback C<sub>F</sub> and Rise Time vs Photodiode C<sub>D</sub>

connection. The LT1634 reference places 1.25V at the noninverting input of the LT1880, which then maintains its inverting input at the same voltage by driving 1mA of current through the RTD and the total 1.25k $\Omega$  of resistance set by R1 and R2. Imprecise components R4 and C1 ensure circuit stability, which would otherwise be excessively dependant on the cable characteristics. R5 is also noncritical and is included to improve ESD immunity and decouple any cable capacitance from the LT1880's output. The 4-wire cable allows Kelvin sensing of the RTD voltage while excluding the cable IR drops from the voltage reading. With 1mA excitation, a 1k $\Omega$  RTD will have 1V across it at 0°C, and +3.85mV/°C temperature response. This voltage can be easily read in myriad ways, with the best method depending on the temperature region to be emphasized and the particular ADC that will be reading the voltage.



\*OMEGA F3141 1k $\Omega$ , 0.1% PLATINUM RTD (800) 826-6342

Figure 5. Single Supply Current Source for Platinum RTD

# SIMPLIFIED SCHEMATIC

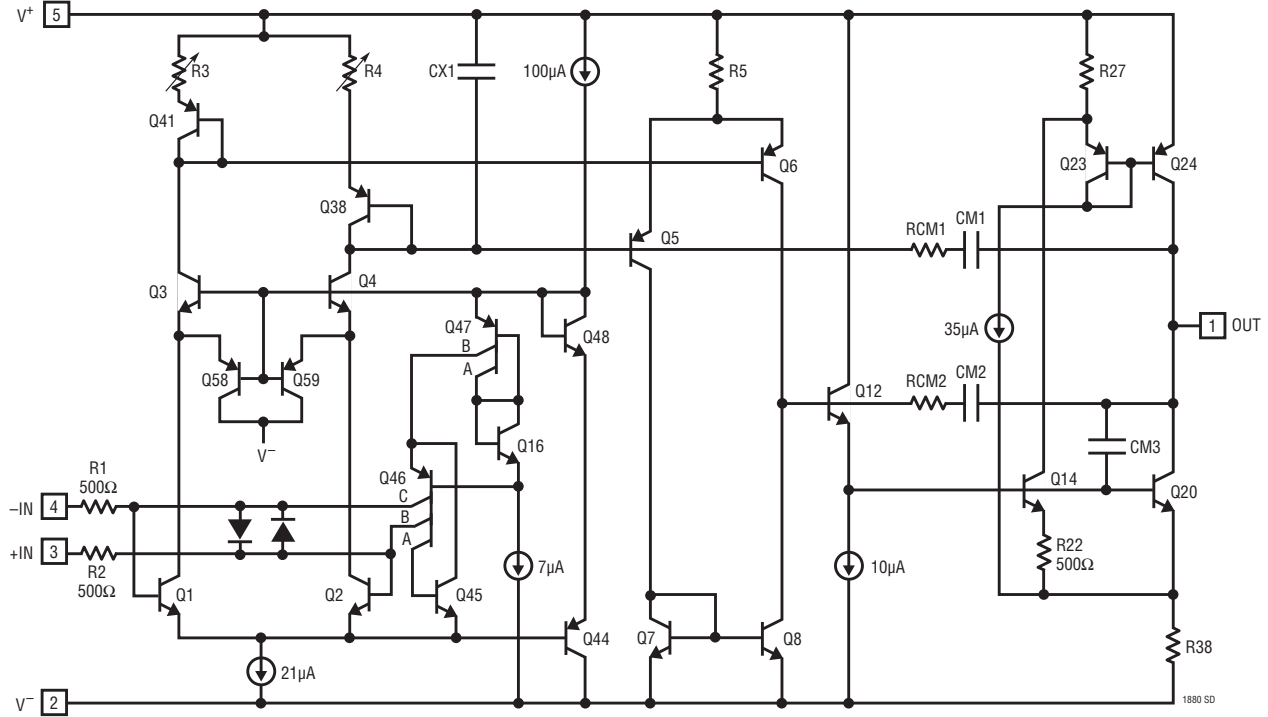

# PACKAGE DESCRIPTION

**S5 Package**  
**5-Lead Plastic TSOT-23**  
 (Reference LTC DWG # 05-08-1635)

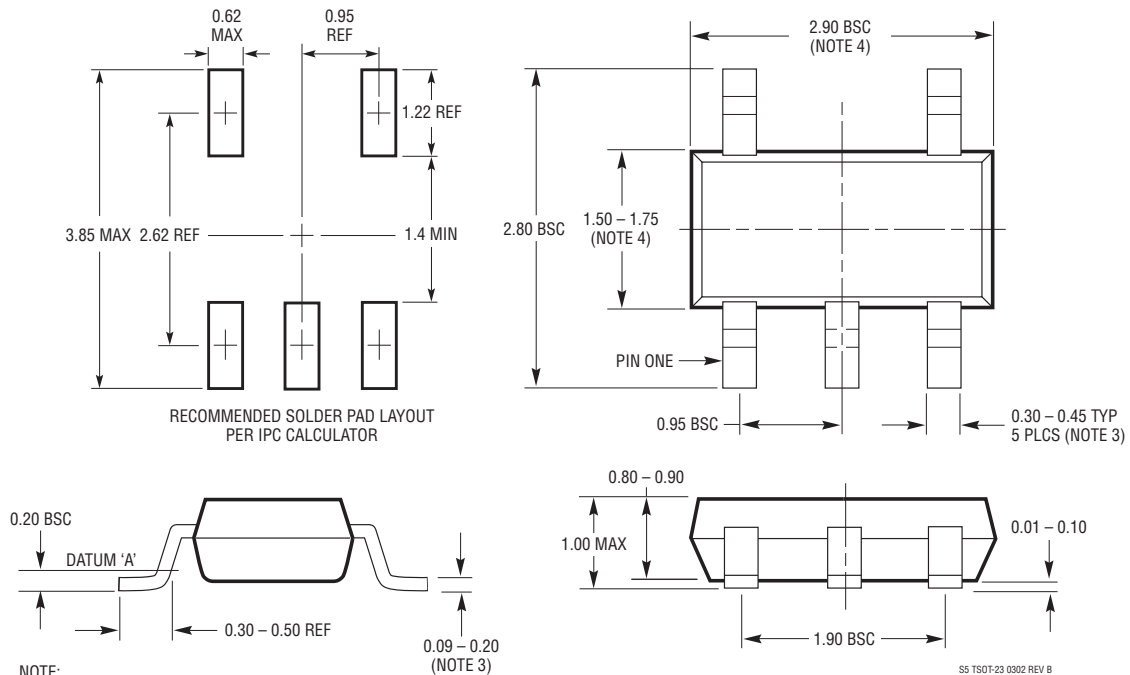

- NOTE:
1. DIMENSIONS ARE IN MILLIMETERS
  2. DRAWING NOT TO SCALE
  3. DIMENSIONS ARE INCLUSIVE OF PLATING
  4. DIMENSIONS ARE EXCLUSIVE OF MOLD FLASH AND METAL BURR
  5. MOLD FLASH SHALL NOT EXCEED 0.254mm
  6. JEDEC PACKAGE REFERENCE IS MO-193

S5 TSOT-23 0302 REV B

## TYPICAL APPLICATION

### All SOT-23 JFET Input Transimpedance Photodiode Amplifier

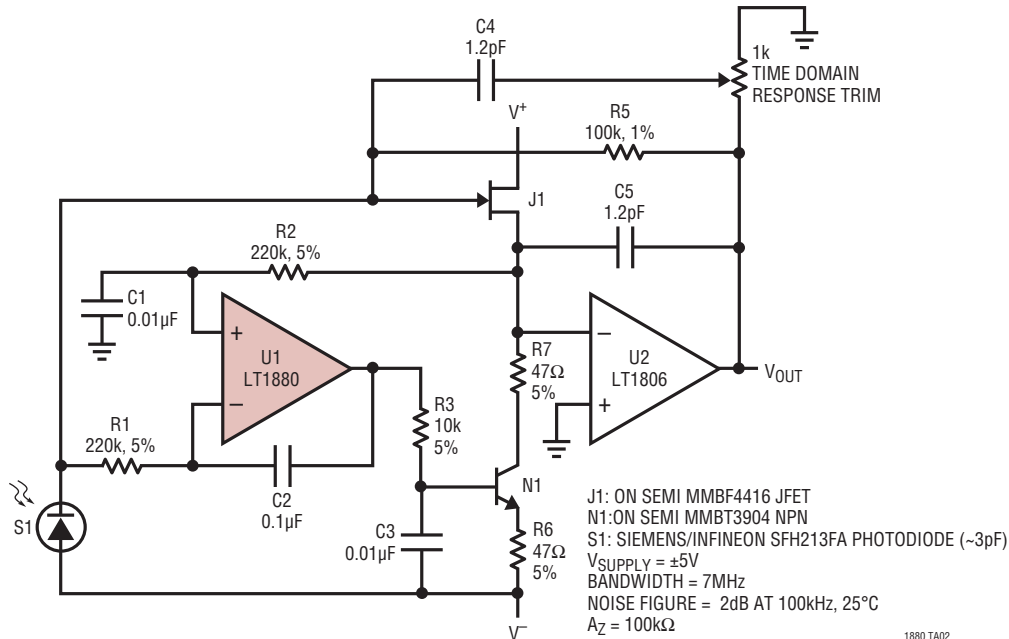

## RELATED PARTS

PART NUMBER	DESCRIPTION	COMMENTS
LT1782	Rugged, General Purpose SOT-23 Op Amp	Rail-to-Rail I/O
LT1792	Low Noise JFET Op Amp	4.2nV/ $\sqrt{Hz}$
LT1881/LT1882	Dual/Quad Precision Op Amps	50μV $V_{OS(MAX)}$ , 200pA $I_{B(MAX)}$ Rail-to-Rail Output
LTC2050	Zero Drift Op Amp in SOT-23	3μV $V_{OS(MAX)}$ , Rail-to-Rail Output
LT6010	135μA Rail-to-Rail Output Precision Op Amp	Lower Power Version of LT1880

## Looking for pricing, stock, or lifecycle information?

Click below to explore more details on WIN SOURCE:

 [View LT1880IS5#TRPBF on WIN SOURCE](#)

 [Linear Technology](#) Information

## Optimize Your Supply Chain with WIN SOURCE Solutions

-  Global Sourcing Solution
-  Obsolete Management
-  Cost Control Management
-  Shortage Management
-  Alternative Solution
-  Excess Inventory Management