



**THE DATASHEET OF  
LT1674IS#PBF**



# 2 $\mu$ A Max, $A_V \geq 5$ Single, Dual and Quad Over-The-Top Precision Rail-to-Rail Input and Output Op Amps

## FEATURES

- Gain of 5 Stable
- Low Supply Current: 2 $\mu$ A Max per Amplifier
- Rail-to-Rail Input and Output
- Low Offset Voltage: 375 $\mu$ V Max
- Over-The-Top™ Inputs Operate Above  $V^+$
- Gain Bandwidth Product: 12kHz
- Wide Supply Range: 2.2V to 36V
- Single Supply Input Range: -0.3V to 36V
- Low Input Bias Current: 250pA
- Low Input Offset Current: 20pA
- High  $A_{VOL}$ : 100V/mV Minimum Driving 100k $\Omega$  Load
- Output Sources and Sinks 500 $\mu$ A Load Current
- Reverse Battery Protected to 18V

## APPLICATIONS

- Battery- or Solar-Powered Systems
- Portable Instrumentation
- Remote Sensor Amplifier
- Micropower Filter
- Photodiode Amplifier
- High Impedance Circuits

LT, LTC and LT are registered trademarks of Linear Technology Corporation. Over-The-Top is a trademark of Linear Technology Corporation.

## DESCRIPTION

The LT®1672/LT1673/LT1674 are ultralow power ( $I_S \leq 2\mu\text{A}$ ) decompensated ( $A_V \geq 5$ ) op amps with precision specifications. The extremely low supply current is combined with excellent amplifier specifications: input offset voltage is 375 $\mu\text{V}$  maximum with a typical drift of only 0.4 $\mu\text{V}/^\circ\text{C}$ , input offset current is 100pA maximum. A minimum open-loop gain ( $A_{VOL}$ ) of 100V/mV ensures that gain errors are small. The devices' characteristics change little over the supply range of 2.2V to  $\pm 15\text{V}$ . Supply rejection is 90dB and the common mode rejection ratio is 90dB. Operation is specified for 3V, 5V and  $\pm 15\text{V}$  supplies. Reverse battery protection ( $-18\text{V}$  min) and inputs that operate above the positive supply make the LT1672/LT1673/LT1674 easy to use in harsh environments.

The low bias currents and offset current of the amplifier permit the use of megohm level source resistors without introducing significant errors. Voltage noise at 4 $\mu\text{V}_{\text{P-P}}$  is remarkably low considering the low supply current. For unity gain stable versions of these amplifiers, see the LT1494/LT1495/LT1496.

The LT1672 is available in the 8-pin MSOP, PDIP and SO packages. The LT1673 is available in plastic 8-pin PDIP and SO-8 packages with the standard dual op amp pinout. The LT1674 is available in 14-pin PDIP and SO packages.

## TYPICAL APPLICATION

Single Supply, 60 $\mu\text{W}$  Precision Instrumentation Amplifier

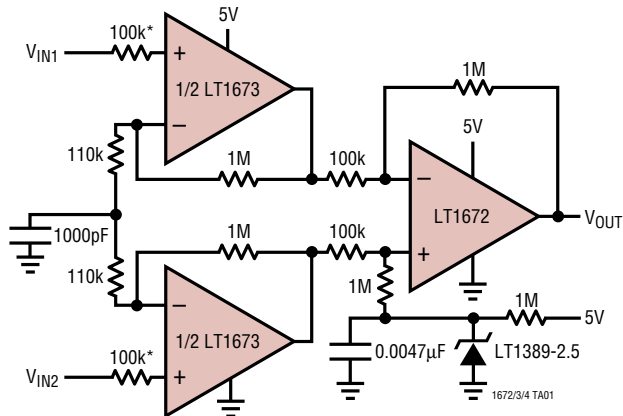

$A_V = 100$   
 BANDWIDTH = 1kHz  
 CMRR = 65dB AT 120Hz  
 \*500V TRANSIENT PROTECTION  
 TOTAL SUPPLY CURRENT = 12 $\mu\text{A}$

TC  $V_{OS}$  Distribution

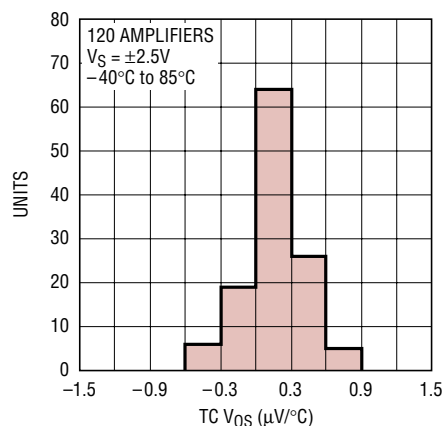

1672/3/4 TA02

# LT1672/LT1673/LT1674

## ABSOLUTE MAXIMUM RATINGS (Note 1)

Total Supply Voltage ( $V^+$ to $V^-$ ) .....	36V	Specified Temperature Range (Note 3) ...	$-40^{\circ}\text{C}$ to $85^{\circ}\text{C}$
Differential Input Voltage .....	36V	Storage Temperature Range .....	$-65^{\circ}\text{C}$ to $150^{\circ}\text{C}$
Input Current .....	$\pm 10\text{mA}$	Junction Temperature .....	$150^{\circ}\text{C}$
Output Short-Circuit Duration .....	Continuous	Lead Temperature (Soldering, 10 sec) .....	$300^{\circ}\text{C}$
Operating Temperature Range (Note 2) ..	$-40^{\circ}\text{C}$ to $85^{\circ}\text{C}$		

## PACKAGE/ORDER INFORMATION

<p>MS8 PACKAGE 8-LEAD PLASTIC MSOP</p> <p><math>T_{JMAX} = 150^{\circ}\text{C}</math>, <math>\theta_{JA} = 250^{\circ}\text{C}/\text{W}</math></p>	ORDER PART NUMBER	<p>N8 PACKAGE 8-LEAD PDIP      S8 PACKAGE 8-LEAD PLASTIC SO</p> <p><math>T_{JMAX} = 150^{\circ}\text{C}</math>, <math>\theta_{JA} = 130^{\circ}\text{C}/\text{W}</math> (N8) <math>T_{JMAX} = 150^{\circ}\text{C}</math>, <math>\theta_{JA} = 190^{\circ}\text{C}/\text{W}</math> (S8)</p>	ORDER PART NUMBER
	LT1672CMS8 LT1672IMS8		LT1672CN8 LT1672CS8 LT1672IN8 LT1672IS8
	MS8 PART MARKING		S8 PART MARKING
LTFH LTFJ	1672 1672I		
<p>N8 PACKAGE 8-LEAD PDIP      S8 PACKAGE 8-LEAD PLASTIC SO</p> <p><math>T_{JMAX} = 150^{\circ}\text{C}</math>, <math>\theta_{JA} = 150^{\circ}\text{C}/\text{W}</math> (N8) <math>T_{JMAX} = 150^{\circ}\text{C}</math>, <math>\theta_{JA} = 190^{\circ}\text{C}/\text{W}</math> (S8)</p>	ORDER PART NUMBER	<p>N PACKAGE 14-LEAD PDIP      S PACKAGE 14-LEAD PLASTIC SO</p> <p><math>T_{JMAX} = 150^{\circ}\text{C}</math>, <math>\theta_{JA} = 110^{\circ}\text{C}/\text{W}</math> (N) <math>T_{JMAX} = 150^{\circ}\text{C}</math>, <math>\theta_{JA} = 150^{\circ}\text{C}/\text{W}</math> (S)</p>	ORDER PART NUMBER
	LT1673CN8 LT1673CS8 LT1673IN8 LT1673IS8		LT1674CN LT1674CS LT1674IN LT1674IS
	S8 PART MARKING		
1673 1673I			

Consult factory for parts specified with wider operating temperature ranges.

## ELECTRICAL CHARACTERISTICS

$T_A = 25^{\circ}\text{C}$ ,  $V_S = 5\text{V}$ ,  $0\text{V}$ ;  $V_S = 3\text{V}$ ,  $0\text{V}$ ;  $V_{CM} = V_O = \text{half supply}$ , unless otherwise noted.

SYMBOL	PARAMETER	CONDITIONS	MIN	TYP	MAX	UNITS
$V_{OS}$	Input Offset Voltage	$V_S = 5\text{V}$		150	375	$\mu\text{V}$
		$V_S = 3\text{V}$		200	475	$\mu\text{V}$
		$V_S = 5\text{V}$ , MS8 Package		150	475	$\mu\text{V}$
		$V_S = 3\text{V}$ , MS8 Package		200	575	$\mu\text{V}$
$I_B$	Input Bias Current	(Note 5)		250	1000	$\text{pA}$
		$V_{CM} = 10\text{V}$ (Note 6)		180	360	$\text{nA}$
$I_{OS}$	Input Offset Current	(Note 5)		20	100	$\text{pA}$
		Input Noise Voltage	0.1Hz to 10Hz		4	$\mu\text{V}_{\text{P-P}}$

## ELECTRICAL CHARACTERISTICS

$T_A = 25^\circ\text{C}$ ,  $V_S = 5\text{V}$ ,  $0\text{V}$ ;  $V_S = 3\text{V}$ ,  $0\text{V}$ ;  $V_{CM} = V_O = \text{half supply}$ , unless otherwise noted.

SYMBOL	PARAMETER	CONDITIONS	MIN	TYP	MAX	UNITS
$e_n$	Input Noise Voltage Density	$f = 100\text{Hz}$		185		$\text{nV}/\sqrt{\text{Hz}}$
$i_n$	Input Noise Current Density	$f = 100\text{Hz}$		10		$\text{fA}/\sqrt{\text{Hz}}$
$A_{VOL}$	Large-Signal Voltage Gain	$V_S = 5\text{V}$ , $V_O = 0.25\text{V}$ to $4.5\text{V}$ , $R_L = 100\text{k}$	100	500		$\text{V}/\text{mV}$
		$V_S = 3\text{V}$ , $V_O = 0.25\text{V}$ to $2.5\text{V}$ , $R_L = 100\text{k}$	50	250		$\text{V}/\text{mV}$
	Input Voltage Range		0		36	V
CMRR	Common Mode Rejection Ratio	$V_{CM} = 0\text{V}$ to $4\text{V}$ , $V_S = 5\text{V}$	90	106		dB
		$V_{CM} = 0\text{V}$ to $10\text{V}$ , $V_S = 5\text{V}$	74	95		dB
PSRR	Power Supply Rejection Ratio	$V_S = 2.2\text{V}$ to $12\text{V}$ , $V_{CM} = V_O = 0.5\text{V}$	90	99		dB
	Minimum Operating Supply Voltage			2.1	2.2	V
$V_{OL}$	Output Voltage Swing LOW	No Load		50	100	mV
		$I_{SINK} = 100\mu\text{A}$		210	410	mV
$V_{OH}$	Output Voltage Swing HIGH	No Load	$V^+ - 0.07$	$V^+ - 0.035$		V
		$I_{SOURCE} = 100\mu\text{A}$	$V^+ - 0.32$	$V^+ - 0.160$		V
$I_{SC}$	Short-Circuit Current	(Note 5)	0.7	1.3		mA
$I_S$	Supply Current per Amplifier	(Note 6)		1.5	2	$\mu\text{A}$
	Reverse Supply Voltage	$I_S = 10\mu\text{A}$ per Amplifier	-18			V
SR	Slew Rate	$A_V = -5$ , $V_S = \pm 10\text{V}$	1.6	5		$\text{V}/\text{ms}$
GBW	Gain Bandwidth Product	$f = 100\text{Hz}$		12		kHz

The ● denotes the specifications which apply over the temperature range of  $0^\circ\text{C} \leq T_A \leq 70^\circ\text{C}$ .  $V_S = 5\text{V}$ ,  $0\text{V}$ ;  $V_S = 3\text{V}$ ,  $0\text{V}$ ;  $V_{CM} = V_O = \text{half supply}$ , unless otherwise noted. (Note 3)

SYMBOL	PARAMETER	CONDITIONS	MIN	TYP	MAX	UNITS
$V_{OS}$	Input Offset Voltage	$V_S = 5\text{V}$	●	175	425	$\mu\text{V}$
		$V_S = 3\text{V}$	●	225	525	$\mu\text{V}$
		$V_S = 5\text{V}$ , MS8 Package	●	175	525	$\mu\text{V}$
		$V_S = 3\text{V}$ , MS8 Package	●	225	625	$\mu\text{V}$
$V_{OS\ TC}$	Input Offset Voltage Drift	(Note 4)	●	0.4	2	$\mu\text{V}/^\circ\text{C}$
$I_B$	Input Bias Current	(Note 5)	●	250	1200	pA
		$V_{CM} = 10\text{V}$ (Note 6)	●	240	500	nA
$I_{OS}$	Input Offset Current	(Note 5)	●	20	120	pA
$A_{VOL}$	Large-Signal Voltage Gain	$V_S = 5\text{V}$ , $V_O = 0.25\text{V}$ to $4.5\text{V}$ , $R_L = 100\text{k}$	●	75	280	$\text{V}/\text{mV}$
		$V_S = 3\text{V}$ , $V_O = 0.25\text{V}$ to $2.5\text{V}$ , $R_L = 100\text{k}$	●	40	150	$\text{V}/\text{mV}$
	Input Voltage Range		●	0.2	36	V
CMRR	Common Mode Rejection Ratio	$V_{CM} = 0.2\text{V}$ to $4\text{V}$ , $V_S = 5\text{V}$	●	89	106	dB
		$V_{CM} = 0.2\text{V}$ to $10\text{V}$ , $V_S = 5\text{V}$	●	64	85	dB
PSRR	Power Supply Rejection Ratio	$V_S = 2.4\text{V}$ to $12\text{V}$ , $V_{CM} = V_O = 0.5\text{V}$	●	89	99	dB
	Minimum Operating Supply Voltage		●	2.3	2.4	V
$V_{OL}$	Output Voltage Swing LOW	No Load	●	55	110	mV
		$I_{SINK} = 100\mu\text{A}$	●	225	450	mV
$V_{OH}$	Output Voltage Swing HIGH	No Load	●	$V^+ - 0.08$	$V^+ - 0.04$	V
		$I_{SOURCE} = 100\mu\text{A}$	●	$V^+ - 0.36$	$V^+ - 0.18$	V
$I_{SC}$	Short-Circuit Current	(Note 5)	●	0.6	1.1	mA
$I_S$	Supply Current per Amplifier	(Note 6)	●	1.9	2.8	$\mu\text{A}$

## ELECTRICAL CHARACTERISTICS

The ● denotes the specifications which apply over the temperature range of  $-40^{\circ}\text{C} \leq T_A \leq 85^{\circ}\text{C}$ .  $V_S = 5\text{V}$ ,  $0\text{V}$ ;  $V_S = 3\text{V}$ ,  $0\text{V}$ ;  $V_{\text{CM}} = V_0 = \text{half supply}$ , unless otherwise noted. (Note 3)

SYMBOL	PARAMETER	CONDITIONS	MIN	TYP	MAX	UNITS
$V_{\text{OS}}$	Input Offset Voltage	$V_S = 5\text{V}$	●	200	475	$\mu\text{V}$
		$V_S = 3\text{V}$	●	250	575	$\mu\text{V}$
		$V_S = 5\text{V}$ , MS8 Package	●	200	575	$\mu\text{V}$
		$V_S = 3\text{V}$ , MS8 Package	●	250	675	$\mu\text{V}$
$V_{\text{OS TC}}$	Input Offset Voltage Drift	(Note 4)	●	0.4	2	$\mu\text{V}/^{\circ}\text{C}$
$I_B$	Input Bias Current	(Note 5)	●	250	1700	$\text{pA}$
		$V_{\text{CM}} = 10\text{V}$ (Note 6)	●	275	750	$\text{nA}$
$I_{\text{OS}}$	Input Offset Current	(Note 5)	●	20	170	$\text{pA}$
$A_{\text{VOL}}$	Large-Signal Voltage Gain	$V_S = 5\text{V}$ , $V_0 = 0.25\text{V}$ to $4.5\text{V}$ , $R_L = 100\text{k}$	●	55	215	$\text{V}/\text{mV}$
		$V_S = 3\text{V}$ , $V_0 = 0.25\text{V}$ to $2.5\text{V}$ , $R_L = 100\text{k}$	●	30	115	$\text{V}/\text{mV}$
	Input Voltage Range		●		36	$\text{V}$
CMRR	Common Mode Rejection Ratio	$V_{\text{CM}} = 0.2\text{V}$ to $4\text{V}$ , $V_S = 5\text{V}$	●	88	106	$\text{dB}$
		$V_{\text{CM}} = 0.2\text{V}$ to $10\text{V}$ , $V_S = 5\text{V}$	●	62	75	$\text{dB}$
PSRR	Power Supply Rejection Ratio	$V_S = 2.7\text{V}$ to $12\text{V}$ , $V_{\text{CM}} = V_0 = 0.5\text{V}$	●	88	99	$\text{dB}$
		Minimum Operating Supply Voltage	●		2.6	2.7
$V_{\text{OL}}$	Output Voltage Swing LOW	No Load	●	60	120	$\text{mV}$
		$I_{\text{SINK}} = 100\mu\text{A}$	●	245	490	$\text{mV}$
$V_{\text{OH}}$	Output Voltage Swing HIGH	No Load	●	$V^+ - 0.10$	$V^+ - 0.05$	$\text{mV}$
		$I_{\text{SOURCE}} = 100\mu\text{A}$	●	$V^+ - 0.38$	$V^+ - 0.19$	$\text{mV}$
$I_{\text{SC}}$	Short-Circuit Current	(Note 5)	●	0.4	0.9	$\text{mA}$
$I_S$	Supply Current per Amplifier	(Note 6)	●	2.1	3.1	$\mu\text{A}$

$T_A = 25^{\circ}\text{C}$ ,  $V_S = \pm 15\text{V}$ ,  $V_{\text{CM}} = V_0 = 0\text{V}$ , unless otherwise noted.

SYMBOL	PARAMETER	CONDITIONS	MIN	TYP	MAX	UNITS
$V_{\text{OS}}$	Input Offset Voltage			200	575	$\mu\text{V}$
		MS8 Package		200	675	$\mu\text{V}$
$I_B$	Input Bias Current			25	1000	$\text{pA}$
$I_{\text{OS}}$	Input Offset Current			20	100	$\text{pA}$
$A_{\text{VOL}}$	Large-Signal Voltage Gain	$V_0 = \pm 10\text{V}$ , $R_L = 100\text{k}$	100	360		$\text{V}/\text{mV}$
		Input Voltage Range	-15		21	$\text{V}$
CMRR	Common Mode Rejection Ratio	$V_{\text{CM}} = -15\text{V}$ to $14\text{V}$	100	120		$\text{dB}$
PSRR	Power Supply Rejection Ratio	$V_S = \pm 5\text{V}$ to $\pm 15\text{V}$	96	120		$\text{dB}$
$V_{\text{OL}}$	Output Voltage Swing LOW	$R_L = 1\text{M}$		-14.85	-14.70	$\text{V}$
		$R_L = 100\text{k}$		-14.75	-14.50	$\text{V}$
$V_{\text{OH}}$	Output Voltage Swing HIGH	$R_L = 1\text{M}$	14.78	14.89		$\text{V}$
		$R_L = 100\text{k}$	14.62	14.81		$\text{V}$
$I_{\text{SC}}$	Short-Circuit Current		0.7	1.5		$\text{mA}$
$I_S$	Supply Current per Amplifier			1.9	2.8	$\mu\text{A}$

## ELECTRICAL CHARACTERISTICS

The ● denotes the specifications which apply over the temperature range of  $0^{\circ}\text{C} \leq T_A \leq 70^{\circ}\text{C}$ ,  $V_S = \pm 15\text{V}$ ,  $V_{CM} = V_O = 0\text{V}$ , unless otherwise noted. (Note 3)

SYMBOL	PARAMETER	CONDITIONS		MIN	TYP	MAX	UNITS
$V_{OS}$	Input Offset Voltage		●		225	625	$\mu\text{V}$
		MS8 Package	●		225	725	$\mu\text{V}$
$I_B$	Input Bias Current		●		250	1200	$\text{pA}$
$I_{OS}$	Input Offset Current		●		20	120	$\text{pA}$
$A_{VOL}$	Large-Signal Voltage Gain	$V_O = \pm 10\text{V}$ , $R_L = 100\text{k}$	●	60	240		$\text{V/mV}$
		Input Voltage Range	●	-14.8		21	$\text{V}$
CMRR	Common Mode Rejection Ratio	$V_{CM} = -14.8\text{V}$ to $14\text{V}$	●	98	120		$\text{dB}$
PSRR	Power Supply Rejection Ratio	$V_S = \pm 5\text{V}$ to $\pm 15\text{V}$	●	94	120		$\text{dB}$
$V_{OL}$	Output Voltage Swing LOW	$R_L = 1\text{M}$	●		-14.84	-14.67	$\text{V}$
		$R_L = 100\text{k}$	●		-14.73	-14.46	$\text{V}$
$V_{OH}$	Output Voltage Swing HIGH	$R_L = 1\text{M}$	●	14.76	14.88		$\text{V}$
		$R_L = 100\text{k}$	●	14.58	14.79		$\text{mV}$
$I_{SC}$	Short-Circuit Current		●	0.6	1.3		$\text{mA}$
$I_S$	Supply Current per Amplifier		●		2.4	3.5	$\mu\text{A}$

The ● denotes the specifications which apply over the temperature range of  $-40^{\circ}\text{C} \leq T_A \leq 85^{\circ}\text{C}$ ,  $V_S = \pm 15\text{V}$ ,  $V_{CM} = V_O = 0\text{V}$ , unless otherwise noted. (Note 3)

SYMBOL	PARAMETER	CONDITIONS		MIN	TYP	MAX	UNITS
$V_{OS}$	Input Offset Voltage		●		250	675	$\mu\text{V}$
		MS8 Package	●		250	775	$\mu\text{V}$
$I_B$	Input Bias Current		●		250	1700	$\text{pA}$
$I_{OS}$	Input Offset Current		●		20	170	$\text{pA}$
$A_{VOL}$	Large-Signal Voltage Gain	$V_O = \pm 10\text{V}$ , $R_L = 100\text{k}$	●	50	200		$\text{V/mV}$
		Input Voltage Range	●	-14.8		21	$\text{V}$
CMRR	Common Mode Rejection Ratio	$V_{CM} = -14.8\text{V}$ to $14\text{V}$	●	96	114		$\text{dB}$
PSRR	Power Supply Rejection Ratio	$V_S = \pm 5\text{V}$ to $\pm 15\text{V}$	●	92	120		$\text{dB}$
$V_{OL}$	Output Voltage Swing LOW	$R_L = 1\text{M}$	●		-14.83	-14.66	$\text{V}$
		$R_L = 100\text{k}$	●		-14.72	-14.44	$\text{V}$
$V_{OH}$	Output Voltage Swing HIGH	$R_L = 1\text{M}$	●	14.74	14.87		$\text{V}$
		$R_L = 100\text{k}$	●	14.54	14.77		$\text{V}$
$I_{SC}$	Short-Circuit Current		●	0.4	1.1		$\text{mA}$
$I_S$	Supply Current per Amplifier		●		2.8	4.2	$\mu\text{A}$

**Note 1:** Absolute Maximum Ratings are those values beyond which the life of the device may be impaired.

**Note 2:** The LT1672C/LT1673C/LT1674C and LT1672I/LT1673I/LT1674I are guaranteed functional over the Operating Temperature Range of  $-40^{\circ}\text{C}$  to  $85^{\circ}\text{C}$ .

**Note 3:** The LT1672C/LT1673C/LT1674C are guaranteed to meet specified performance from  $0^{\circ}\text{C}$  to  $70^{\circ}\text{C}$ . The LT1672C/LT1673C/LT1674C are designed, characterized and expected to meet specified performance from

$-40^{\circ}\text{C}$  to  $85^{\circ}\text{C}$  but are not tested or QA sampled at these temperatures. The LT1672I/LT1673I/LT1674I are guaranteed to meet specified performance from  $-40^{\circ}\text{C}$  to  $85^{\circ}\text{C}$ .

**Note 4:** This parameter is not 100% tested.

**Note 5:**  $V_S = 5\text{V}$  limit guaranteed by correlation to  $V_S = 3\text{V}$  and  $V_S = \pm 15\text{V}$  tests.

**Note 6:**  $V_S = 3\text{V}$  limit guaranteed by correlation to  $V_S = 5\text{V}$  and  $V_S = \pm 15\text{V}$  tests.

# TYPICAL PERFORMANCE CHARACTERISTICS

**Distribution of Input Offset Voltage**

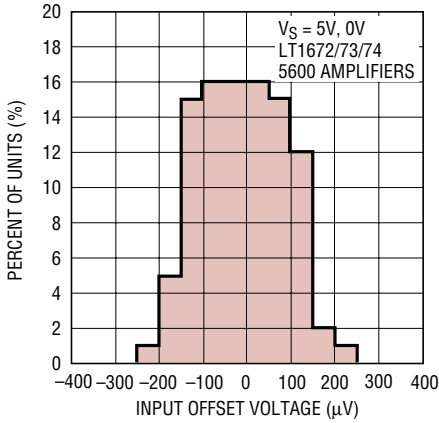

1672/3/4 G01

**Supply Current vs Temperature**

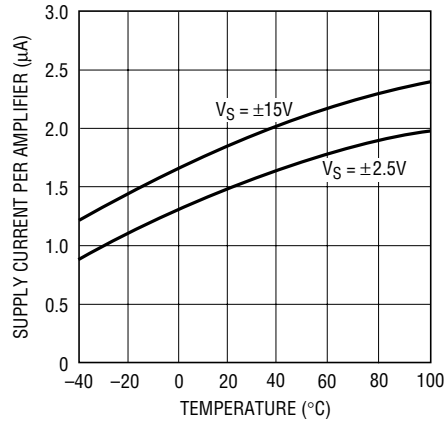

1672/3/4 G02

**Minimum Supply Voltage**

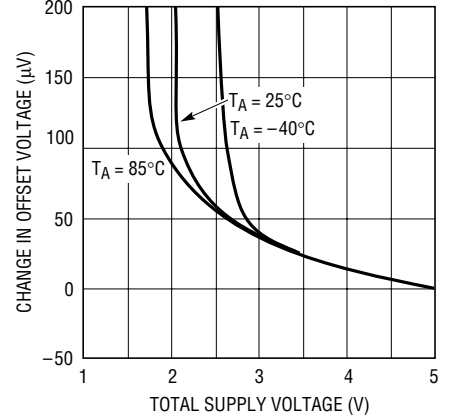

1672/3/4 G03

**Output Saturation Voltage vs Load Current (Output Low)**

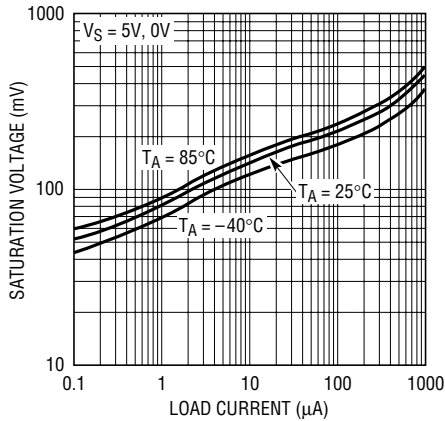

1672/3/4 G04

**Output Saturation Voltage vs Load Current (Output High)**

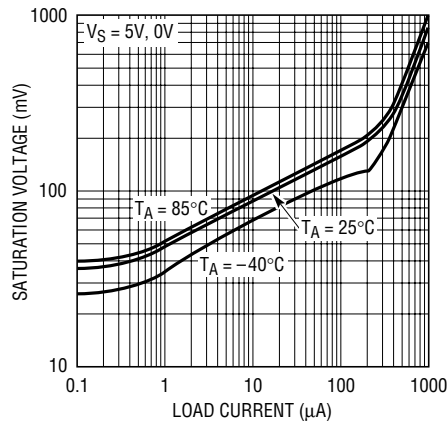

1672/3/4 G05

**Input Bias Current vs Common Mode Voltage**

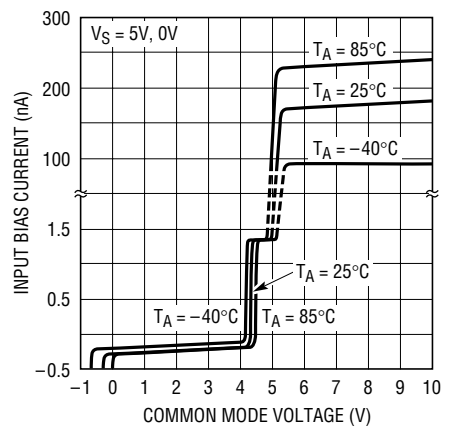

1672/3/4 G06

**Gain and Phase Shift vs Frequency**

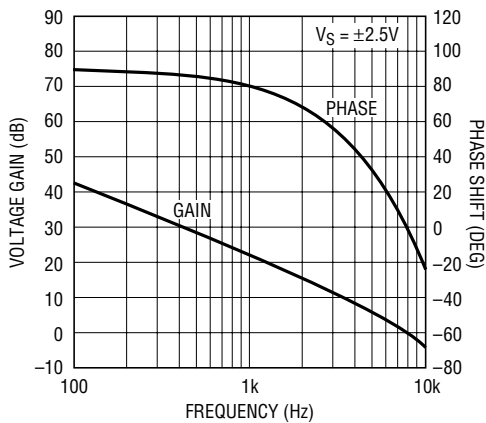

1672/3/4 G07

**Noise Voltage Spectrum**

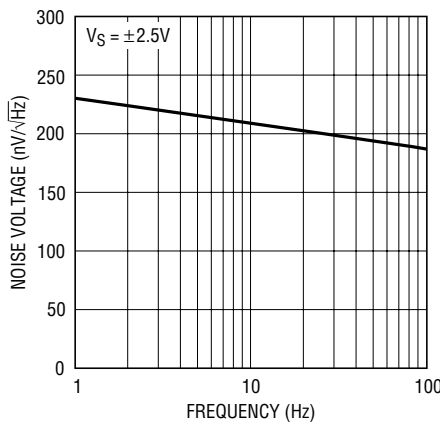

1672/3/4 G08

**Noise Current Spectrum**

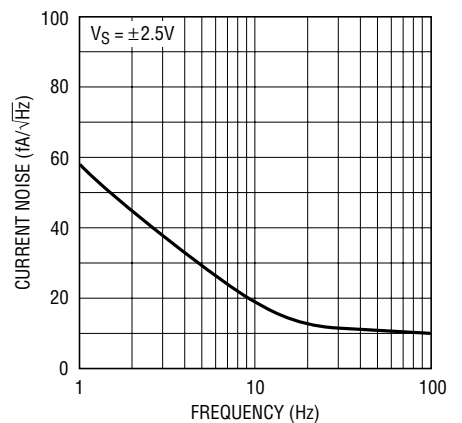

1672/3/4 G09

# TYPICAL PERFORMANCE CHARACTERISTICS

**Gain Bandwidth and Phase Margin vs Supply Voltage**

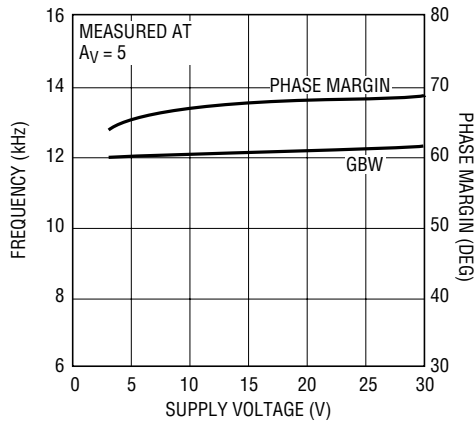

1672/3/4 G10

**0.1Hz to 10Hz Output Voltage Noise**

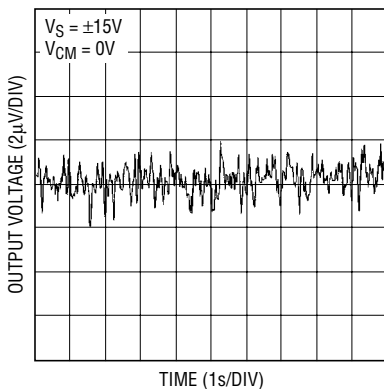

1672/3/4 G07

**Capacitive Load Handling**

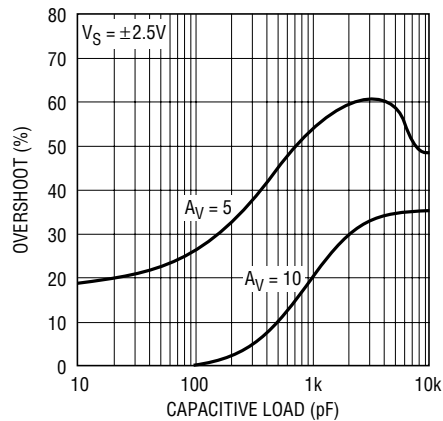

1672/3/4 G12

**Common Mode Rejection Ratio vs Frequency**

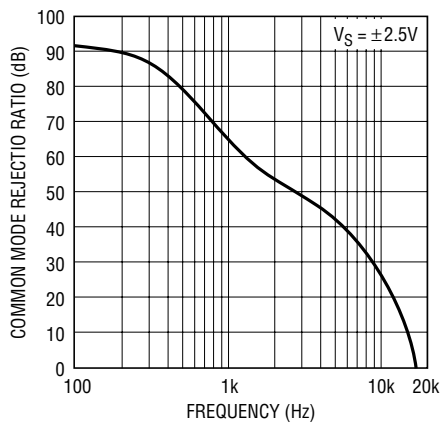

1672/3/4 G13

**Power Supply Rejection Ratio vs Frequency**

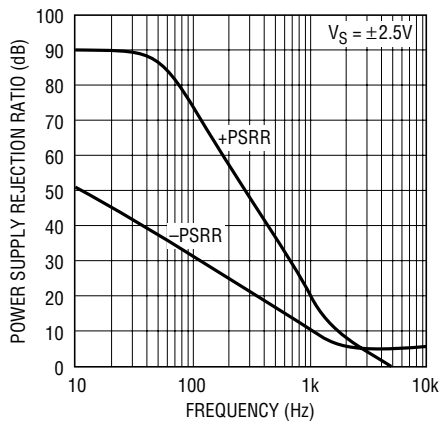

1672/3/4 G14

**Output Impedance vs Frequency**

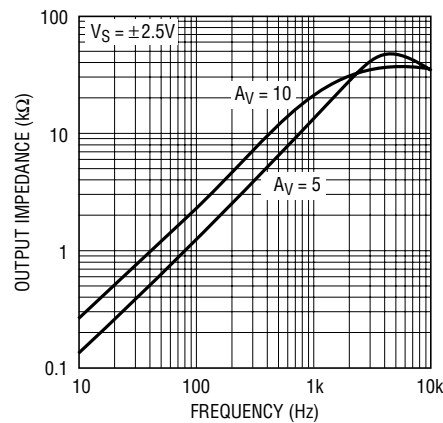

1672/3/4 G15

**Warm-Up Drift vs Time**

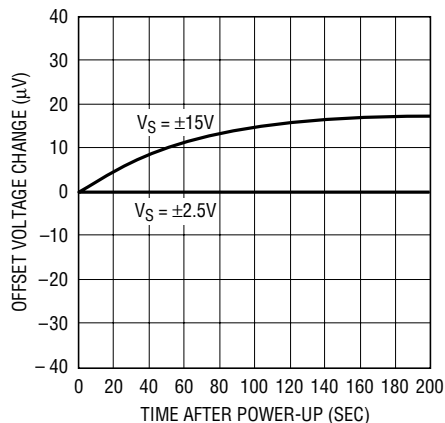

1672/3/4 G16

**Open-Loop Gain  $V_S = 5V, 0V$**

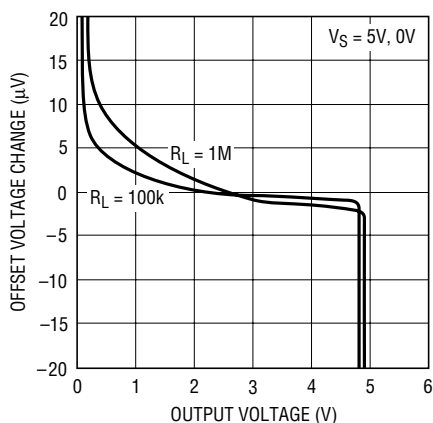

1672/3/4 G17

**Open-Loop Gain  $V_S = \pm 15V$**

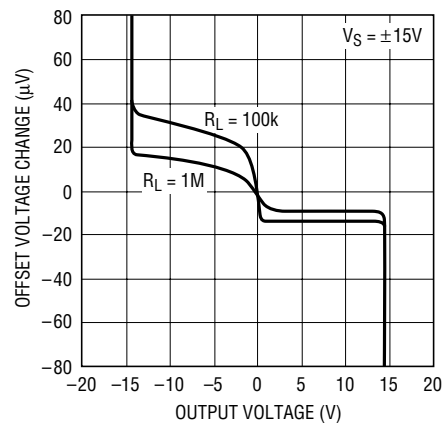

1672/3/4 G18

## TYPICAL PERFORMANCE CHARACTERISTICS

Small-Signal Response

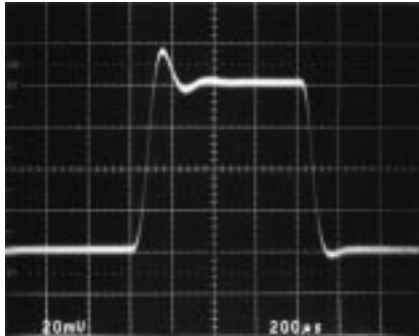

$V_S = \pm 15V$   
 $C_L = 100pF$   
 $A_V = 5$   
 1672/3/4 G19

Small-Signal Response

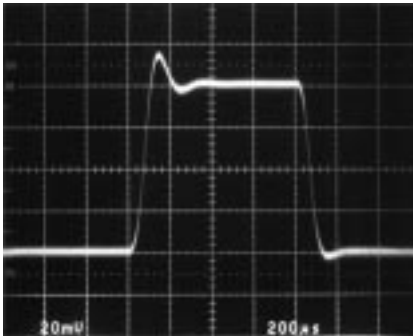

$V_S = 5V$   
 $C_L = 100pF$   
 $A_V = 5$   
 1672/3/4 G20

Large-Signal Response

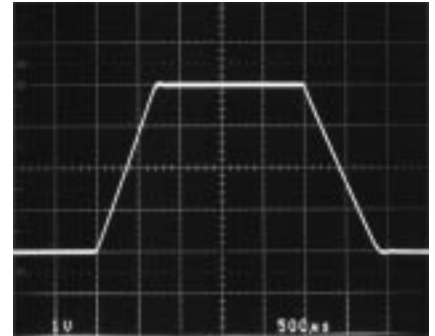

$V_S = 5V$   
 $C_L = 100pF$   
 $A_V = 5$   
 1672/3/4 G21

## APPLICATIONS INFORMATION

### Start-Up Characteristics

Micropower op amps are sometimes not micropower during start-up, wreaking havoc on low current supplies. In the worst case, there may not be enough supply current available to take the system up to nominal voltages. Figure 1 is a graph of LT1673 supply current vs supply voltage for the three limit cases of input offset that could occur during start-up. The circuits are shown in Figure 2. One circuit creates a positive offset, forcing the output to come up saturated high. Another circuit creates a negative offset, forcing the output to come up saturated low, while the last brings up the output at half supply. In all cases, the supply current is well behaved. Supply current is highest with the output forced high, so if one amplifier is unused, it is best to force the output low or at half supply.

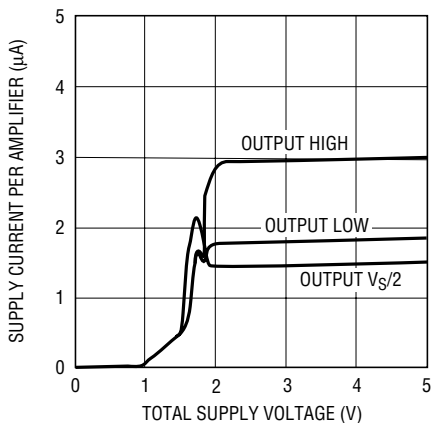

1672/3/4 F01

Figure 1. Start-Up Characteristics

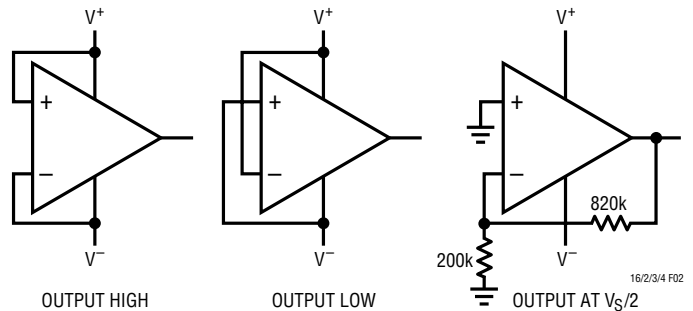

1672/3/4 F02

Figure 2. Circuits for Start-Up Characteristics

### Reverse Battery

The LT1672/LT1673/LT1674 are protected against reverse battery voltages up to 18V. In the event a reverse battery condition occurs, the supply current is typically less than 100nA (inputs grounded and outputs open). For typical single supply applications with ground referred loads and feedback networks, no other precautions are required. If the reverse battery condition results in a negative voltage at either the input pins or output pin, the current into the pin should be limited by an external resistor to less than 10mA.

### Inputs

While the LT1672/LT1673/LT1674 will function normally with its inputs taken above the positive supply, the common mode range does not extend beyond approximately 300mV below the negative supply at room temperature.

## APPLICATIONS INFORMATION

The device will not be damaged if the inputs are taken lower than 300mV below the negative supply as long as the current out of the pin is limited to less than 10mA. However, the output phase is not guaranteed and the supply current will increase.

### Output

The graph, Capacitive Load Handling, shows amplifier stability with the output biased at half supply. If the output is to be operated within about 100mV of the positive rail, the allowable load capacitance is less. With this output voltage, the worst case occurs at  $A_V = 5$  and light loads, where the load capacitance should be less than 500pF with a 5V supply and less than 100pF with a 30V supply.

### Rail-to-Rail Operation

The simplified schematic, Figure 3, details the circuit design approach of the LT1672/LT1673/LT1674. The amplifier topology is a three-stage design consisting of a rail-to-rail input stage, that continues to operate with the inputs above the positive rail, a folded cascode second stage that develops most of the voltage gain, and a rail-to-rail common emitter stage that provides the current gain.

The input stage is formed by two diff amps Q1-Q2 and Q3-Q6. For signals with a common mode voltage between  $V_{EE}$

and  $(V_{CC} - 0.8V)$ , Q1 and Q2 are active. When the input common mode exceeds  $(V_{CC} - 0.8V)$ , Q7 turns on, diverting the current from diff amp Q1-Q2 to current mirror Q8-Q9. The current from Q8 biases on the other diff amp consisting of PNP's Q5-Q6 and NPN's Q3-Q4. Though Q5-Q6 are driven from the emitters rather than the base, the basic diff amp action is the same. When the common mode voltage is between  $(V_{CC} - 0.8V)$  and  $V_{CC}$ , devices Q3 and Q4 act as followers, forming a buffer between the amplifier inputs and the emitters of the Q5-Q6. If the common mode voltage is taken above  $V_{CC}$ , Schottky diodes D1 and D2 reverse bias and devices Q3 and Q4 then act as diodes. The diff amp formed by Q5-Q6 operates normally, however, the input bias current increases to the emitter current of Q5-Q6, which is typically 180nA. The graph, Input Bias Current vs Common Mode Voltage found in the Typical Performance Characteristics section, shows these transitions at three temperatures.

The collector currents of the two-input pairs are combined in the second stage consisting of Q11 to Q16, which furnishes most of the voltage gain. Capacitor C1 sets the amplifier bandwidth. The output stage is configured for maximum swing by the use of common emitter output devices Q21 and Q22. Diodes D4 to D6 and current source Q15 set the output quiescent current.

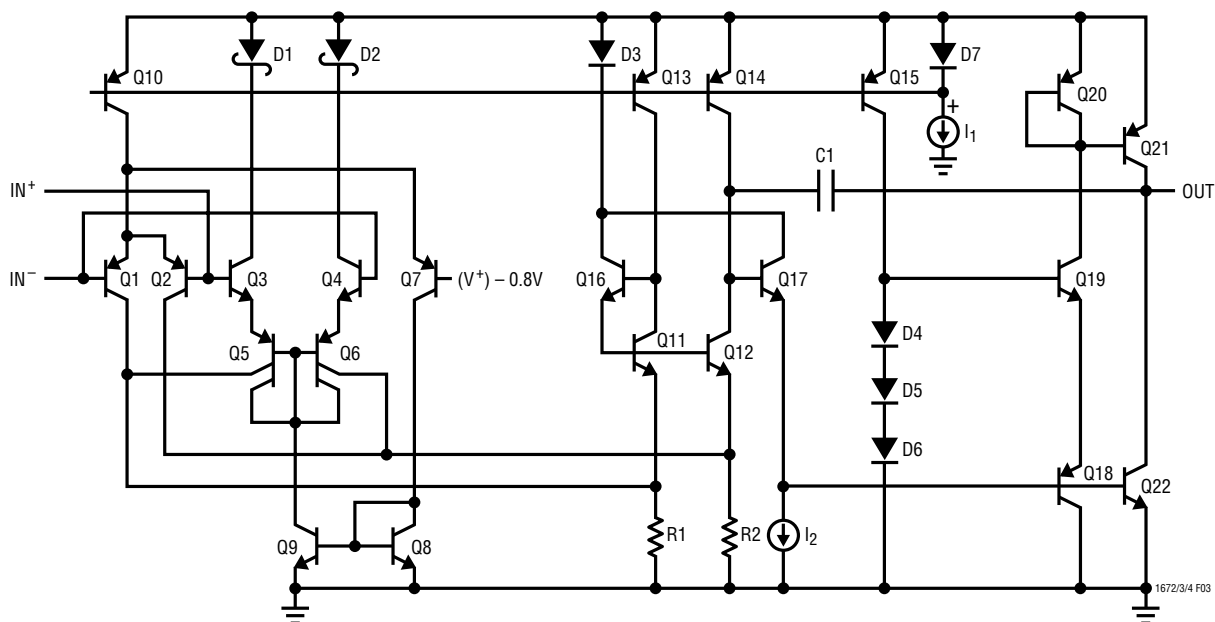
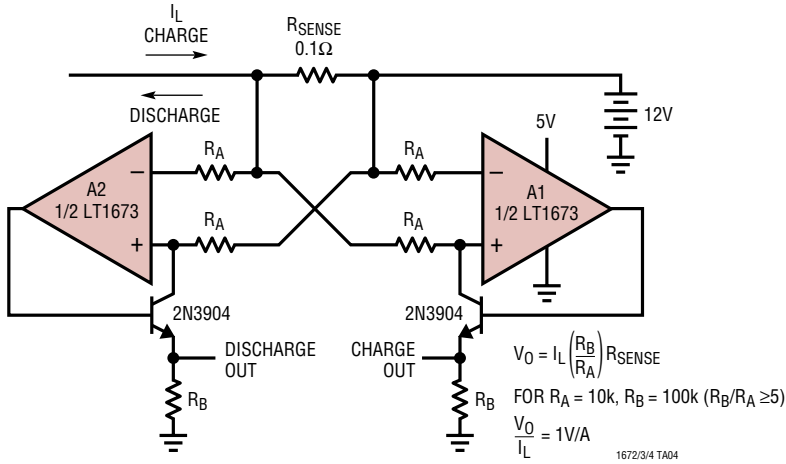

Figure 3. Simplified Schematic

**TYPICAL APPLICATIONS**

**Battery Current Monitor**



**Over-the-Top Comparator with Hysteresis**

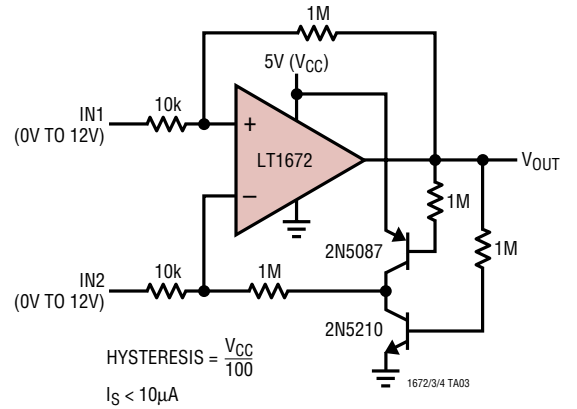

**PACKAGE DESCRIPTION** Dimensions in inches (millimeters) unless otherwise noted.

**MS8 Package**  
**8-Lead Plastic MSOP**  
(LTC DWG # 05-08-1660)

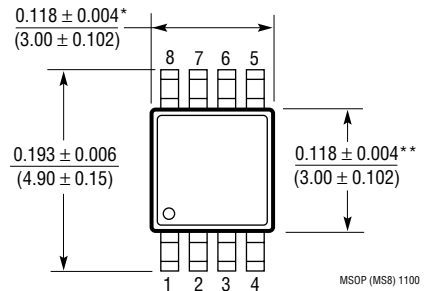
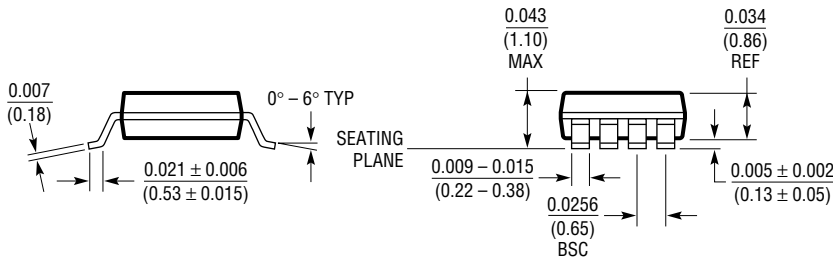

\* DIMENSION DOES NOT INCLUDE MOLD FLASH, PROTRUSIONS OR GATE BURRS. MOLD FLASH, PROTRUSIONS OR GATE BURRS SHALL NOT EXCEED 0.006\* (0.152mm) PER SIDE

\*\* DIMENSION DOES NOT INCLUDE INTERLEAD FLASH OR PROTRUSIONS. INTERLEAD FLASH OR PROTRUSIONS SHALL NOT EXCEED 0.006\* (0.152mm) PER SIDE

**N8 Package**  
**8-Lead PDIP (Narrow 0.300)**  
(LTC DWG # 05-08-1510)

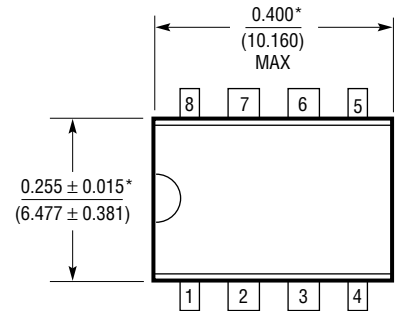
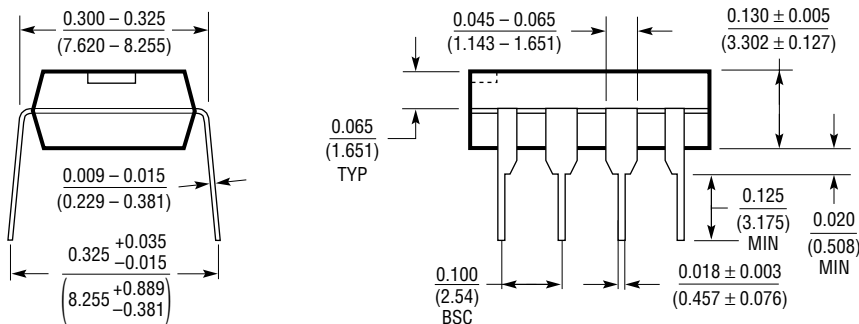

\*THESE DIMENSIONS DO NOT INCLUDE MOLD FLASH OR PROTRUSIONS. MOLD FLASH OR PROTRUSIONS SHALL NOT EXCEED 0.010 INCH (0.254mm)

**PACKAGE DESCRIPTION** Dimensions in inches (millimeters) unless otherwise noted.

**S8 Package**  
**8-Lead Plastic Small Outline (Narrow 0.150)**  
 (LTC DWG # 05-08-1610)

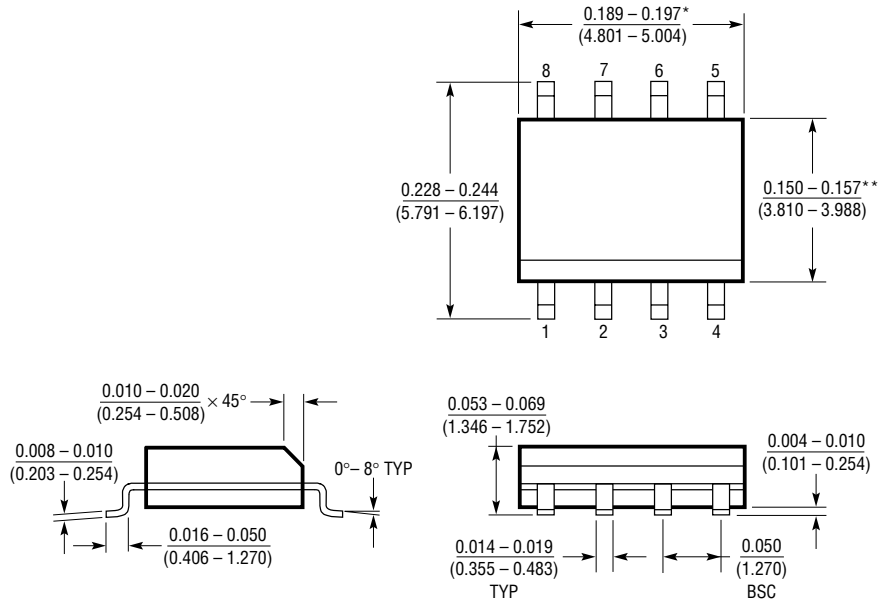

\*DIMENSION DOES NOT INCLUDE MOLD FLASH. MOLD FLASH SHALL NOT EXCEED 0.006" (0.152mm) PER SIDE  
 \*\*DIMENSION DOES NOT INCLUDE INTERLEAD FLASH. INTERLEAD FLASH SHALL NOT EXCEED 0.010" (0.254mm) PER SIDE

S08 1298

**S Package**  
**14-Lead Plastic Small Outline (Narrow 0.150)**  
 (LTC DWG # 05-08-1610)

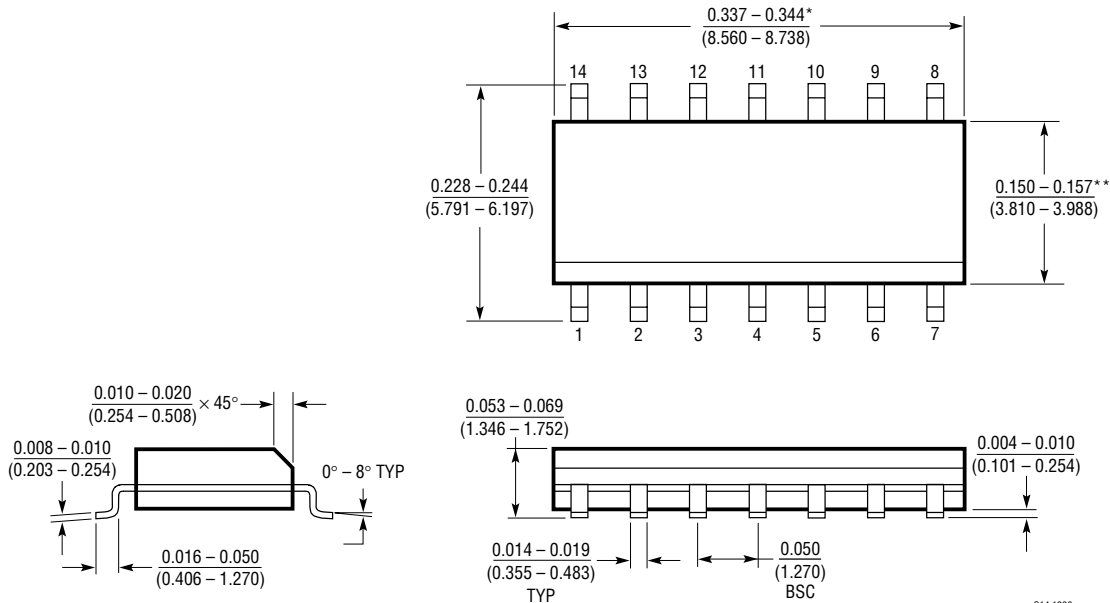

\*DIMENSION DOES NOT INCLUDE MOLD FLASH. MOLD FLASH SHALL NOT EXCEED 0.006" (0.152mm) PER SIDE  
 \*\*DIMENSION DOES NOT INCLUDE INTERLEAD FLASH. INTERLEAD FLASH SHALL NOT EXCEED 0.010" (0.254mm) PER SIDE

S14 1298

## TYPICAL APPLICATION

Micropower Photodiode Amplifier

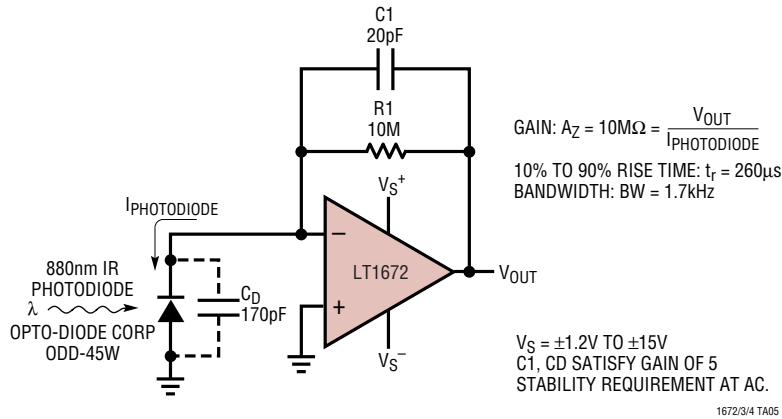

## RELATED PARTS

PART NUMBER	DESCRIPTION	COMMENTS
LTC®1440/41/42	Micropower Single/Dual Comparators with 1% Reference	LTC1440: Single, LTC1441/42: Dual
LTC1443/LTC1444/LTC1445	Micropower Quad Comparators with 1% Reference	LTC1443: 1.182 Reference LTC1444/45: 1.221V Reference and Adjustable Hysteresis
LT1466/LT1467	75µA Dual/Quad Rail-to-Rail Input and Output Op Amps	390µV $V_{OS(MAX)}$ , Gain Bandwidth = 120kHz
LT1490A/LT1491A	50µA Dual/Quad Rail-to-Rail Input and Output Op Amps	950µV $V_{OS(MAX)}$ , Gain Bandwidth = 200kHz
LT1494/LT1495/LT1496	1.5µA Max Single/Dual/Quad Over-the-Top Precision Rail-to-Rail Input and Output Op Amps	Unity Gain Stable Version of the LT1672/LT1673/LT1674
LTC1540	Nanopower Single Comparator with 1% Reference	350nA Supply Current
LT1636	Single Over-the-Top Micropower, Rail-to-Rail Input and Output Op Amp	225µV $V_{OS(MAX)}$ , $I_S = 55\mu A$ (Max), Gain Bandwidth = 200kHz, Shutdown Pin, MSOP
LT2078/LT2079	55µA Dual/Quad Single Supply Op Amps	120µV $V_{OS(MAX)}$ , Gain Bandwidth = 200kHz
LT2178/LT2179	17µA Dual/Quad Single Supply Op Amps	120µV $V_{OS(MAX)}$ , Gain Bandwidth = 60kHz
LT1782	Micropower, Over-The-Top, SOT-23, Rail-to-Rail Input and Output Op Amp	SOT-23, 800µV $V_{OS(MAX)}$ , $I_S = 55\mu A$ (Max), Gain-Bandwidth = 200kHz, Shutdown Pin
LT1783	1.2MHz, Over-The-Top, Micropower, Rail-to-Rail Input and Output Op Amp in SOT-23	SOT-23, 800µV $V_{OS(MAX)}$ , $I_S = 300\mu A$ (Max), Gain-Bandwidth = 1.2MHz, Shutdown Pin

## Looking for pricing, stock, or lifecycle information?

Click below to explore more details on WIN SOURCE:

 [View LT1674IS#PBF on WIN SOURCE](#)

 [Linear Technology](#) Information

## Optimize Your Supply Chain with WIN SOURCE Solutions

-  Global Sourcing Solution
-  Obsolete Management
-  Cost Control Management
-  Shortage Management
-  Alternative Solution
-  Excess Inventory Management