



**THE DATASHEET OF  
LT1641CS8#PBF**





## ABSOLUTE MAXIMUM RATINGS

(Note 1)

Supply Voltage ( $V_{CC}$ )	-0.3V to 100V
Input Voltage (SENSE)	-0.3V to 100V
Input Voltage (TIMER)	-0.3V to 44V
Input Voltage (FB, ON)	-0.3V to 60V
Output Voltage (PWRGD)	-0.3V to 100V
Output Voltage (GATE)	-0.3V to 100V
Operating Temperature Range	
LT1641CS8	0°C to 70°C
LT1641IS8	-40°C to 85°C
Storage Temperature Range	-65°C to 150°C
Lead Temperature (Soldering, 10 sec)	300°C

## PACKAGE/ORDER INFORMATION

S8 PACKAGE  
8-LEAD PLASTIC SO  
 $T_{JMAX} = 125^{\circ}\text{C}$ ,  $\theta_{JA} = 110^{\circ}\text{C/W}$   
**NOT RECOMMENDED FOR NEW DESIGNS**  
SEE LT1641-1/LT1641-2

ORDER PART NUMBER	S8 PART MARKING
LT1641CS8	1641
LT1641IS8	1641I

**Order Options** Tape and Reel: Add #TR  
Lead Free: Add #PBF Lead Free Tape and Reel: Add #TRPBF  
Lead Free Part Marking: <http://www.linear.com/leadfree/>

Consult LTC Marketing for parts specified with wider operating temperature ranges.

## DC ELECTRICAL CHARACTERISTICS

The ● denotes the specifications which apply over the full operating temperature range, otherwise specifications are at  $T_A = 25^{\circ}\text{C}$ .  $V_{CC} = 24\text{V}$

SYMBOL	PARAMETER	CONDITIONS	MIN	TYP	MAX	UNITS	
$V_{CC}$	$V_{CC}$ Operating Range		●	9	80	V	
$I_{CC}$	$V_{CC}$ Supply Current	ON = 3V	●	2	5.5	mA	
$V_{LKO}$	$V_{CC}$ Undervoltage Lockout		●	7.5	8.3	8.8	V
$V_{FBH}$	FB Pin High Voltage Threshold	FB Low to High Transition	●	1.280	1.313	1.345	V
$V_{FBL}$	FB Pin Low Voltage Threshold	FB High to Low Transition	●	1.221	1.233	1.245	V
$V_{FBHST}$	FB Pin Hysteresis Voltage			80		mV	
$I_{INFB}$	FB Pin Input Current	$V_{FB} = \text{GND}$			-1	$\mu\text{A}$	
$\Delta V_{FB}$	FB Pin Threshold Line Regulation	$9\text{V} \leq V_{CC} \leq 80\text{V}$	●		0.05	mV/V	
$V_{SENSETRIP}$	SENSE Pin Trip Voltage ( $V_{CC} - V_{SENSE}$ )	$V_{FB} = 0\text{V}$ $V_{FB} = 1\text{V}$	●	8	12	17	mV
$I_{GATEUP}$	GATE Pin Pull-Up Current	Charge Pump On, $V_{GATE} = 7\text{V}$	●	-5	-10	-20	$\mu\text{A}$
$I_{GATEDN}$	GATE Pin Pull-Down Current	Any Fault Condition, $V_{GATE} = 2\text{V}$	●	35	70	100	mA
$\Delta V_{GATE}$	External N-Channel Gate Drive	$V_{GATE} - V_{CC}$ , $V_{CC} = 10.8\text{V}$ to 20V $V_{CC} = 20\text{V}$ to 80V	●	4.5		18	V
			●	10		18	V
$I_{TIMERUP}$	TIMER Pin Pull-Up Current	$V_{TIMER} = 0\text{V}$	●	-24	-80	-132	$\mu\text{A}$
$I_{TIMERON}$	TIMER Pin Pull-Down Current	$V_{TIMER} = 1\text{V}$	●	1.5	3	5	$\mu\text{A}$
$V_{ONH}$	ON Pin High Threshold	ON Low to High Transition	●	1.280	1.313	1.345	V
$V_{ONL}$	ON Pin Low Threshold	ON High to Low Transition	●	1.221	1.233	1.245	V
$V_{ONHYST}$	ON Pin Hysteresis			80		mV	
$I_{INON}$	ON Pin Input Current	$V_{ON} = \text{GND}$			-1	$\mu\text{A}$	
$V_{OL}$	PWRGD Output Low Voltage	$I_O = 2\text{mA}$ $I_O = 4\text{mA}$	●		0.4	V	
			●		2.5	V	
$I_{OH}$	PWRGD Pin Leakage Current	$V_{PWRGD} = 80\text{V}$	●		10	$\mu\text{A}$	

1641fd

# AC ELECTRICAL CHARACTERISTICS $T_A = 25^\circ\text{C}, V_{CC} = 24\text{V}$

SYMBOL	PARAMETER	CONDITIONS	MIN	TYP	MAX	UNITS
$t_{PHLON}$	ON Low to GATE Low	Figures 1, 2		6		$\mu\text{s}$
$t_{PLHON}$	ON High to GATE High	Figures 1, 2		1.7		$\mu\text{s}$
$t_{PHLFB}$	FB Low to PWRGD Low	Figures 1, 3		3.2		$\mu\text{s}$
$t_{PLHFB}$	FB High to PWRGD High	Figures 1, 3		1.5		$\mu\text{s}$
$t_{PHLSENSE}$	$(V_{CC} - \text{SENSE})$ High to GATE Low	Figures 1, 4	0.5	1	2	$\mu\text{s}$

**Note 1:** Stresses beyond those listed under Absolute Maximum Ratings may cause permanent damage to the device. Exposure to any Absolute Maximum Rating condition for extended periods may affect device reliability and lifetime.

**Note 2:** All currents into device pins are positive; all currents out of device pins are negative. All voltages are referenced to ground unless otherwise specified.

## TYPICAL PERFORMANCE CHARACTERISTICS

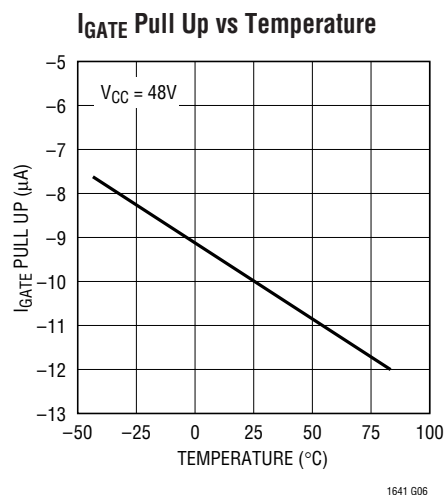
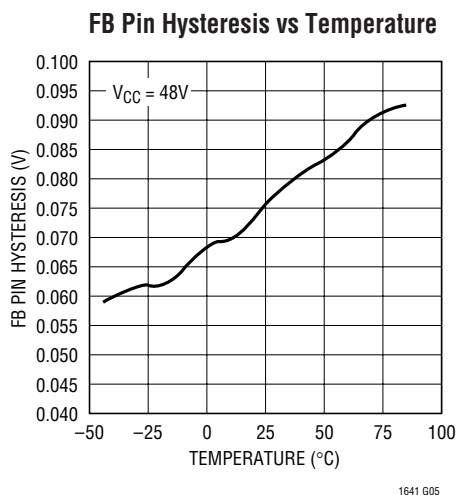
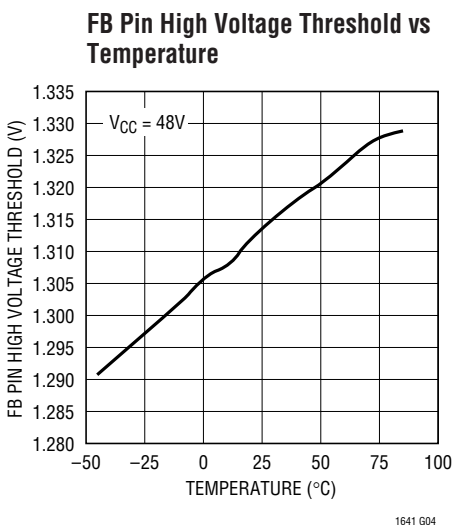
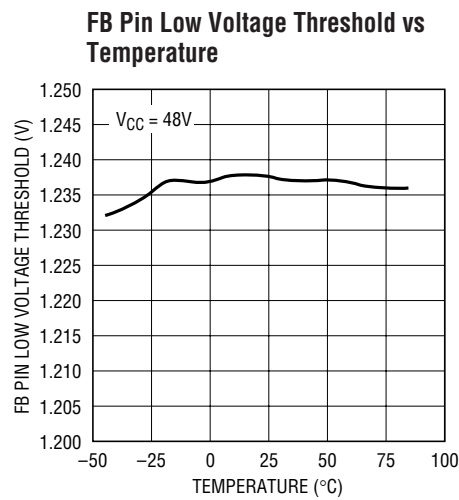
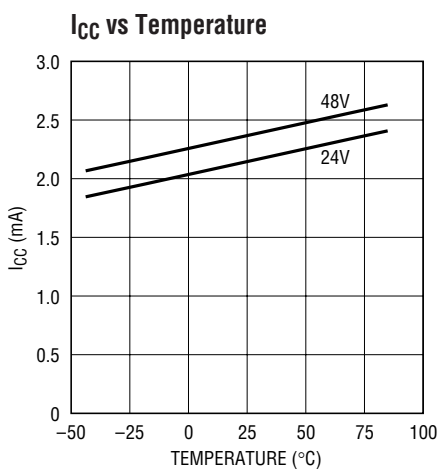
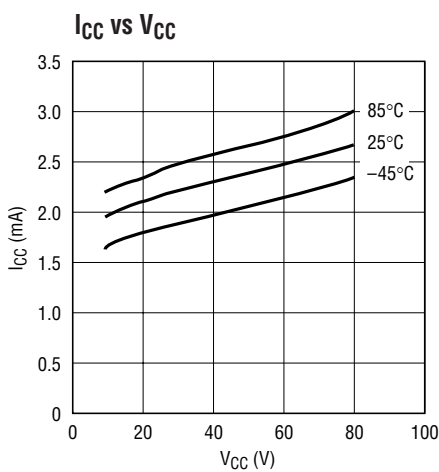

TYPICAL PERFORMANCE CHARACTERISTICS

Gate Drive vs Temperature

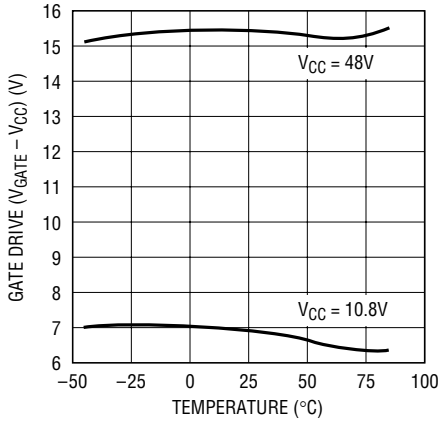

1641 G07

Gate Drive vs V<sub>CC</sub>

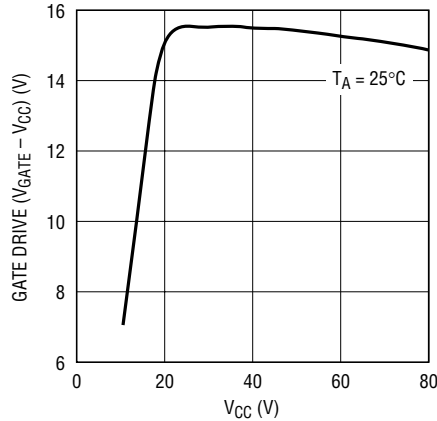

1641 G08

TIMER Pin Pull Up Current vs Temperature

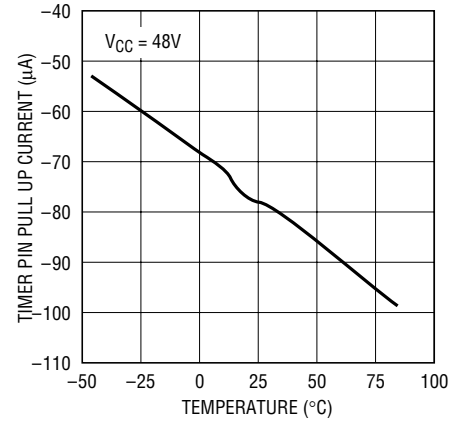

1641 G09

TIMER Pin Pull Up Current vs V<sub>CC</sub>

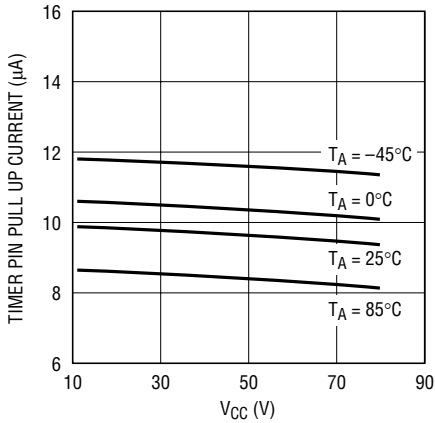

1641 G10

ON Pin High Voltage Threshold vs Temperature

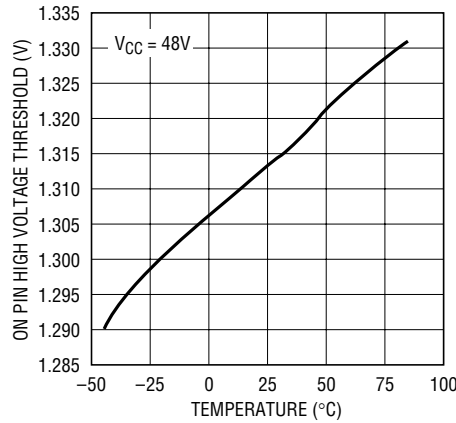

1641 G11

ON Pin Low Voltage Threshold vs Temperature

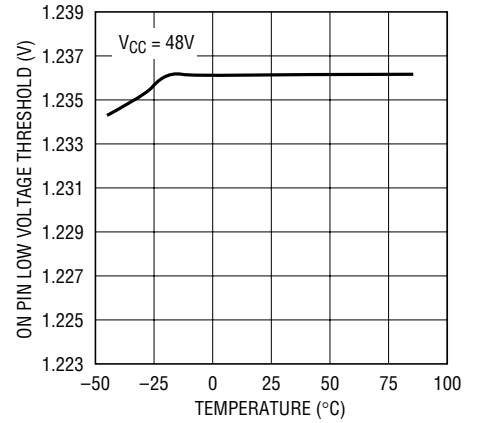

1641 G12

ON Pin Voltage Hysteresis vs Temperature

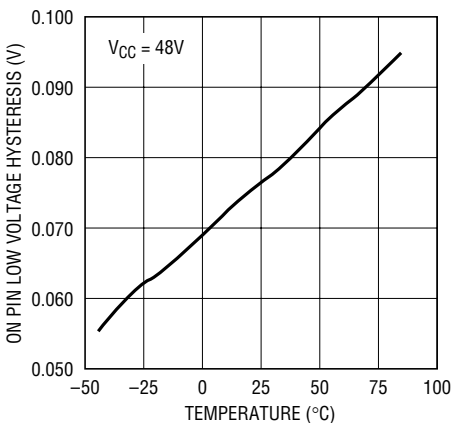

1641 G13

PWRGD V<sub>OUT</sub> Low vs I<sub>LOAD</sub>

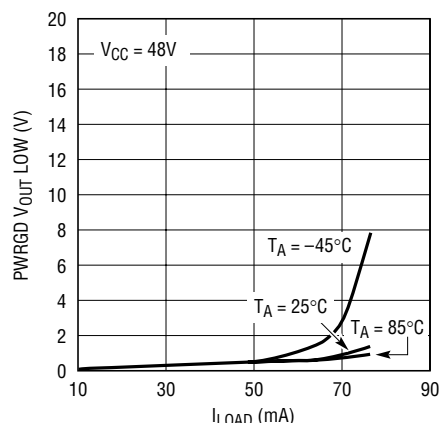

1641 G14

SENSE Pin Regulation Voltage vs V<sub>FEEDBACK</sub>

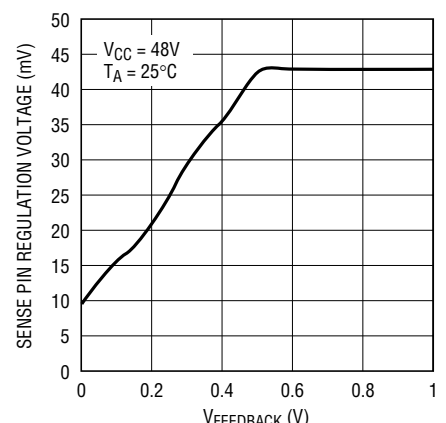

1641 G15

## PIN FUNCTIONS

**ON (Pin 1):** The ON pin is used to implement undervoltage lockout. When the ON pin is pulled below the 1.233V High-to-Low threshold voltage, an undervoltage condition is detected and the GATE pin is pulled low to turn the MOSFET off. When the ON pin rises above the 1.313V Low-to-High threshold voltage, the MOSFET is turned on again.

**FB (Pin 2):** Power Good Comparator Input. It monitors the output voltage with an external resistive divider. When the voltage on the FB pin is lower than the High-to-Low threshold of 1.233V, the PWRGD pin is pulled low and released when the FB pin is pulled above the 1.313V Low-to-High threshold.

The FB pin also effects foldback current limit (see Figure 7 and related discussion).

**PWRGD (Pin 3):** Open Collector Output to GND. The PWRGD pin is pulled low whenever the voltage at the FB pin falls below the High-to-Low threshold voltage. It goes into a high impedance state when the voltage on the FB pin exceeds the Low-to-High threshold voltage. An external pull-up resistor can pull the pin to a voltage higher or lower than  $V_{CC}$ .

**GND (Pin 4):** Chip Ground.

**TIMER (Pin 5):** Timing Input. An external timing capacitor at this pin programs the maximum time the part is allowed to remain in current limit.

When the part goes into current limit, an 80 $\mu$ A pull-up current source starts to charge the timing capacitor. When the voltage on the TIMER pin reaches 1.233V, the GATE pin is pulled low; the pull-up current will be turned off and the capacitor is discharged by a 3 $\mu$ A pull-down current. When the TIMER pin falls below 0.5V, the GATE pin turns on once the ON pin is pulsed low. Use no less than 1.5nF for the timing capacitor, C2.

By connecting a 0.01 $\mu$ F capacitor from the GATE pin to the center tap of a resistive divider at the ON pin, the part automatically restarts after a current limit fault. With a short at the output, the part cycles on and off with a 3.75% on-time duty cycle.

**GATE (Pin 6):** The High Side Gate Drive for the External N-Channel. An internal charge pump guarantees at least 10V of gate drive for supply voltages above 20V and 4.5V gate drive for supply voltages between 10.8V and 20V. The rising slope of the voltage at the GATE is set by an external capacitor connected from the GATE pin to GND and an internal 10 $\mu$ A pull-up current source from the charge pump output.

When the current limit is reached, the GATE pin voltage will be adjusted to maintain a constant voltage across the sense resistor while the timer capacitor starts to charge. If the TIMER pin voltage exceeds 1.233V, the GATE pin will be pulled low.

The GATE pin is pulled to GND whenever the ON pin is pulled low, the  $V_{CC}$  supply voltage drops below the 8.3V undervoltage lockout threshold or the TIMER pin rises above 1.233V.

**SENSE (Pin 7):** The Current Limit Sense Pin. A sense resistor must be placed in the supply path between  $V_{CC}$  and SENSE. The current limit circuit will regulate the voltage across the sense resistor ( $V_{CC} - V_{SENSE}$ ) to 47mV when  $V_{FB}$  is 0.5V or higher. If  $V_{FB}$  drops below 0.5V, the voltage across the sense resistor decreases linearly and stops at 12mV when  $V_{FB}$  is 0V.

To defeat current limit, short the SENSE pin to the  $V_{CC}$  pin.

**$V_{CC}$  (Pin 8):** The Positive Supply Input ranges from 9V to 80V for normal operation.  $I_{CC}$  is typically 2mA. An internal undervoltage lockout circuit disables the chip for inputs less than 8.3V.

**BLOCK DIAGRAM**

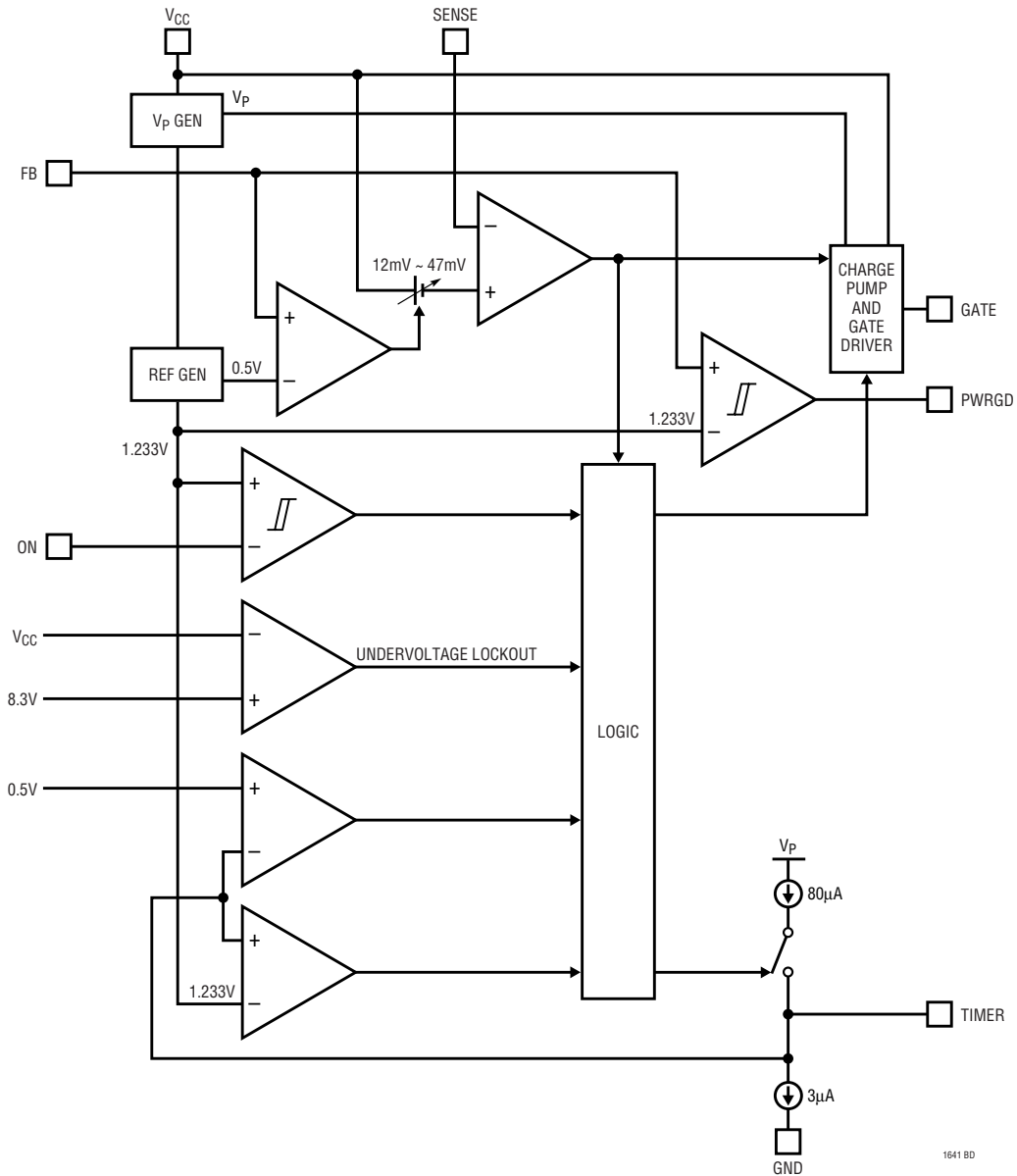

1641 BD

**TEST CIRCUIT**

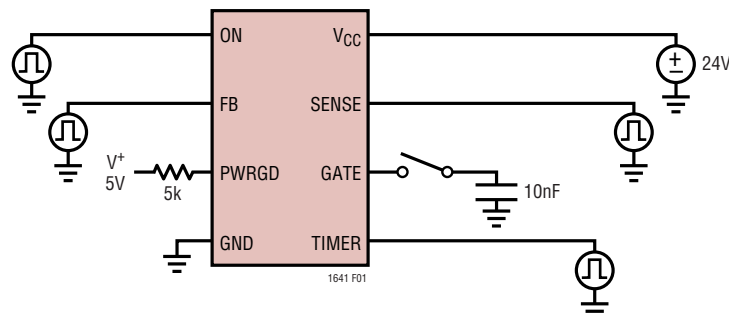

Figure 1

1641fd

## TIMING DIAGRAMS

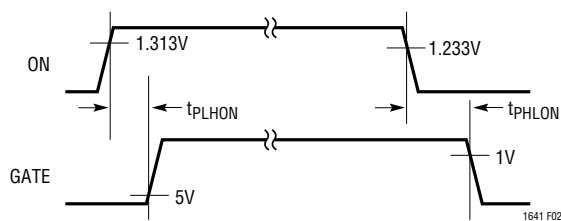

Figure 2. ON to GATE Timing

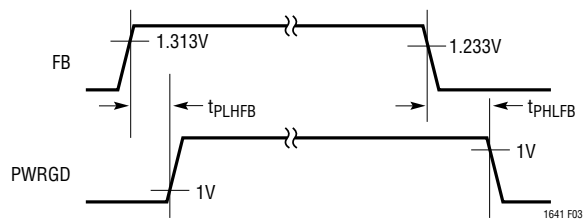

Figure 3. FB to PWRGD Timing

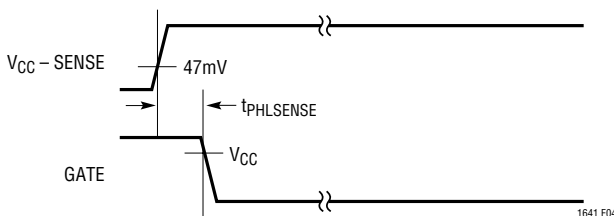

Figure 4. SENSE to GATE Timing

## APPLICATIONS INFORMATION

### Hot Circuit Insertion

When circuit boards are inserted into a live backplane, the supply bypass capacitors on the boards draw high peak currents from the backplane power bus as they charge up. The transient currents can permanently damage the connector pins and glitch the system supply, causing other boards in the system to reset.

The LT1641 is designed to turn on a board's supply voltage in a controlled manner, allowing the board to be safely inserted or removed from a live backplane. The chip also provides undervoltage and overcurrent protection while a power good output signal indicates when the output supply voltage is ready.

### Power-Up Sequence

The power supply on a board is controlled by placing an external N-channel pass transistor (Q1) in the power path (Figure 5). Resistor  $R_S$  provides current detection and capacitor C1 provides control of the GATE slew rate. Resistor R6 provides current control loop compensation while R5 prevents high frequency oscillations in Q1. Resistors R1 and R2 provide undervoltage sensing.

After the power pins first make contact, transistor Q1 is turned off. If the voltage at the ON pin exceeds the turn-on threshold voltage, the voltage on the  $V_{CC}$  pin exceeds the undervoltage lockout threshold, and the voltage on the TIMER pin is less than 1.233V, transistor Q1 will be turned on (Figure 6). The voltage at the GATE pin rises with a slope equal to  $10\mu\text{A}/\text{C}1$  and the supply inrush current is set at  $I_{\text{INRUSH}} = C_L \cdot 10\mu\text{A}/\text{C}1$ . If the voltage across the current sense resistor  $R_S$  gets too high, the inrush current will then be limited by the internal current limit circuitry which adjusts the voltage on the GATE pin to maintain a constant voltage across the sense resistor.

Once the voltage at the output has reached its final value, as sensed by resistors R3 and R4, the PWRGD pin goes high.

### Short-Circuit Protection

The LT1641 features a programmable foldback current limit with an electronic circuit breaker that protects against short-circuits or excessive supply currents. The current limit is set by placing a sense resistor between  $V_{CC}$  (Pin 8) and SENSE (Pin 7).

APPLICATIONS INFORMATION

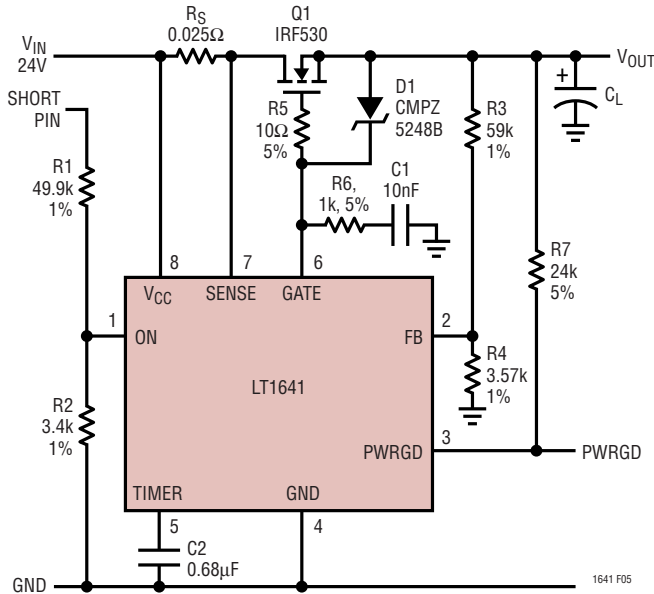

Figure 5. Typical Application

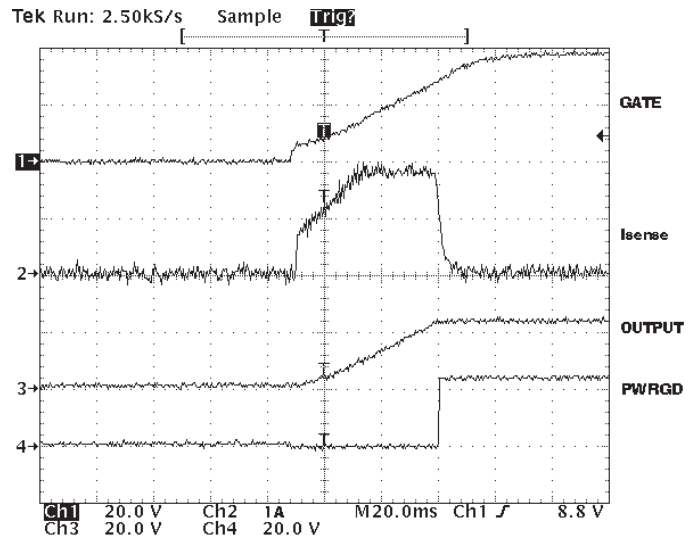

Figure 6. Power-Up Waveforms

To prevent excessive power dissipation in the pass transistor and to prevent voltage spikes on the input supply during short-circuit conditions at the output, the current folds back as a function of the output voltage, which is sensed at the FB pin (Figure 7).

When the voltage at the FB pin is 0V, the current limit circuit drives the GATE pin to force a constant 12mV drop across the sense resistor. As the output voltage at the FB pin increases, the voltage across the sense resistor increases until the FB pin reaches 0.5V, at which point the voltage across the sense resistor is held constant at 47mV.

The maximum current limit is calculated as:

$$I_{LIMIT} = 47\text{mV}/R_{SENSE}$$

For a 0.025Ω sense resistor, the current limit is set at 1.88A and folds back to 480mA when the output is shorted to ground.

The LT1641 also features a variable overcurrent response time. The time required for the chip to regulate the GATE pin (Pin 6) voltage is a function of the voltage across the sense resistor connected between the VCC pin (Pin 8) and the SENSE pin (Pin 7). The larger the voltage, the faster the gate will be regulated. Figure 8 shows the response time as a function of overdrive at the SENSE pin.

TIMER

The TIMER pin (Pin 5) provides a method for programming the maximum time the chip is allowed to operate in current limit. When the current limit circuitry is not active, the TIMER pin is pulled to GND by a 3μA current source. After the current limit circuit becomes active, an 80μA pull-up current source is connected to the TIMER pin and the voltage will rise with a slope equal to 77μA/C<sub>TIMER</sub> as long as the current limit circuit remains active. Once the desired maximum current limit time is set, the capacitor value is: C(nF) = 62 • t(ms).

If the current limit circuit turns off, the TIMER pin will be discharged to GND by the 3μA current source.

Whenever the TIMER pin reaches 1.233V, the GATE pin is immediately pulled to GND and the TIMER pin is pulled back to GND by the 3μA current source. The part is not allowed to turn on again until the voltage at the TIMER pin falls below 0.5V.

The waveform in Figure 9 shows how the output turns off following a short-circuit. The drop across the sense resistor is held at 12mV as the timer ramps up. Since the output did not rise bringing FB above 0.5V, the circuit turns off.

## APPLICATIONS INFORMATION

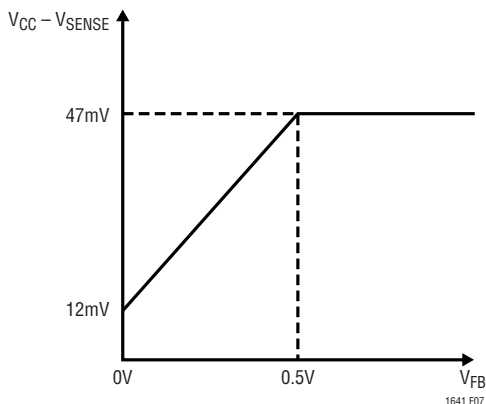

Figure 7. Current Limit Sense Voltage vs Feedback Pin Voltage

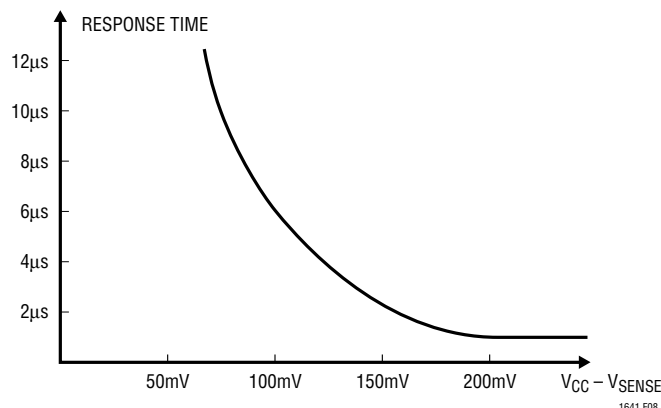

Figure 8. Response Time to Overcurrent

### Automatic Restart

To force the LT1641 to automatically restart after an overcurrent fault, the bottom plate of capacitor C1 can be tied back to the ON pin (Figure 10).

When an overcurrent condition occurs, the GATE pin is driven to maintain a constant voltage across the sense resistor. The capacitor C2 at the TIMER pin will begin to charge. When the voltage at the TIMER pin reaches 1.233V, the GATE pin is immediately pulled to GND and transistor Q1 turns off. Capacitor C1 momentarily pulses the ON pin low and allows the part to turn off. When the voltage at the TIMER pin ramps back down to 0.5V, the LT1641 turns on again. If the short-circuit condition at the output still exists, the cycle will repeat itself indefinitely with a 3.75% on-time duty cycle which prevents Q1 from overheating. The waveforms are shown in Figure 11.

### Undervoltage and Overvoltage Detection

The ON pin can be used to detect an undervoltage condition at the power supply input. The ON pin is internally connected to an analog comparator with 80mV of hysteresis. If the ON pin falls below its threshold voltage (1.233V), the GATE pin is pulled low and is held low until ON is high again.

Figure 12 shows an overvoltage detection circuit. When the input voltage exceeds the Zener diode's breakdown voltage, D2 turns on and starts to pull the TIMER pin high. After the TIMER pin is pulled higher than 1.233V, the fault latch is set and the GATE pin is pulled to GND immediately,

turning off transistor Q1. The waveforms are shown in Figure 13. Operation is restored either by interrupting power or by pulsing ON low.

### Power Good Detection

The LT1641 includes a comparator for monitoring the output voltage. The noninverting input (FB pin) is compared against an internal 1.233V precision reference and exhibits 80mV hysteresis. The comparator's output (PWRGD pin) is an open collector capable of operating from a pull-up as high as 100V.

The PWRGD pin can be used to directly enable/disable a power module with an active high enable input. Figure 14 shows how to use the PWRGD pin to control an active low enable input power module. Signal inversion is accomplished by transistor Q2 and R7.

### Supply Transient Protection

The LT1641 is 100% tested and guaranteed to be safe from damage with supply voltages up to 100V. However, spikes above 100V may damage the part. During a short-circuit condition, the large change in currents flowing through the power supply traces can cause inductive voltage spikes which could exceed 100V. To minimize the spikes, the power trace parasitic inductance should be minimized by using wider traces or heavier trace plating and a surge suppressor placed between  $V_{CC}$  and GND.

APPLICATIONS INFORMATION

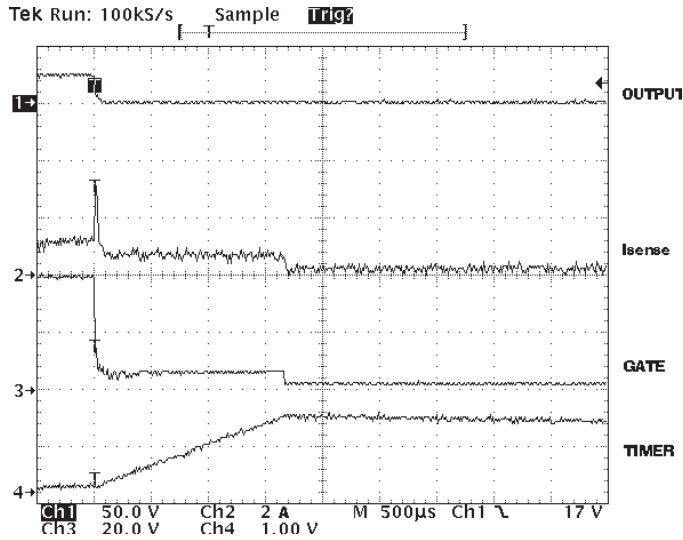

Figure 9. Short-Circuit Waveforms

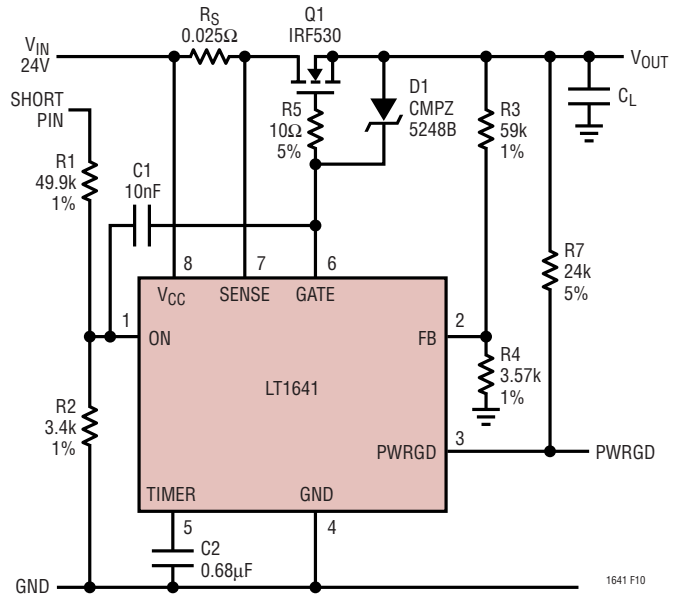

Figure 10. Automatic Restart Application

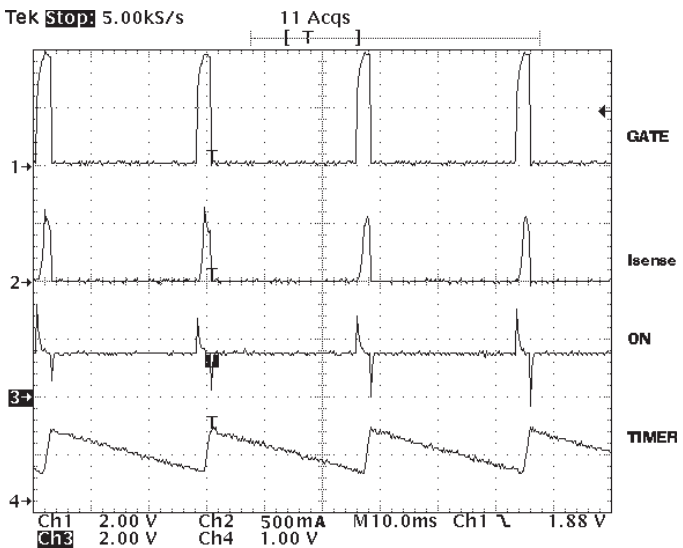

Figure 11. Automatic Restart Waveforms

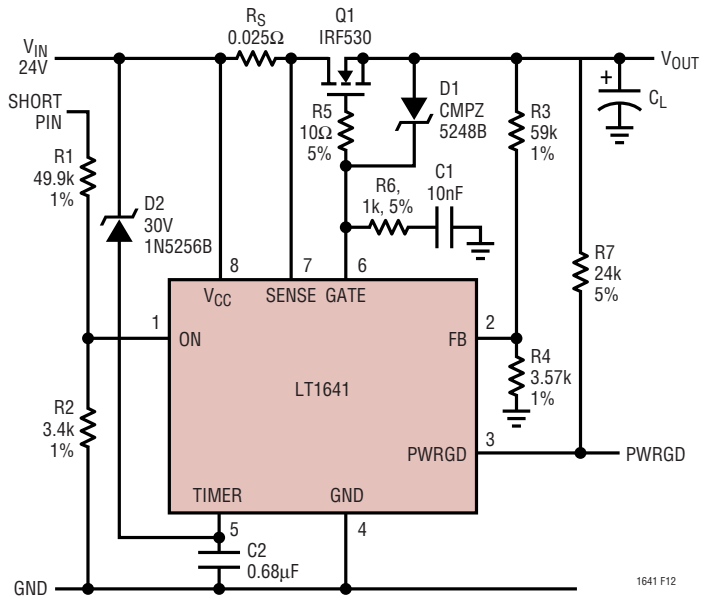

Figure 12. Overtoltage Detection

GATE Pin Voltage

A curve of gate drive vs  $V_{CC}$  is shown in Figure 15. The GATE pin is clamped to a maximum voltage of 18V above the input voltage. At minimum input supply voltage of 9V, the minimum gate drive voltage is 4.5V. When the input supply voltage is higher than 20V, the gate drive voltage is

at least 10V and a regular N-FET can be used. In applications ranges 9V to 24V range, a logic level N-FET must be used with a proper protection Zener diode between its gate and source (as D1 shown is Figure 5).

# APPLICATIONS INFORMATION

## Layout Considerations

To achieve accurate current sensing, a Kelvin connection is recommended. The minimum trace width for 1oz copper foil is 0.02" per amp to make sure the trace stays at a reasonable temperature. 0.03" per amp or wider is recommended. Note that 1oz copper exhibits a sheet resistance of about  $530\mu\Omega/\square$ . Small resistances add up quickly in

high current applications. To make the system immune to noise, the resistor divider to the ON pin needs to be close to the chip and keep traces to  $V_{CC}$  and GND short. A  $0.1\mu F$  capacitor from the ON pin to GND also helps reject induced noise. Figure 16 shows a layout that addresses these issues.

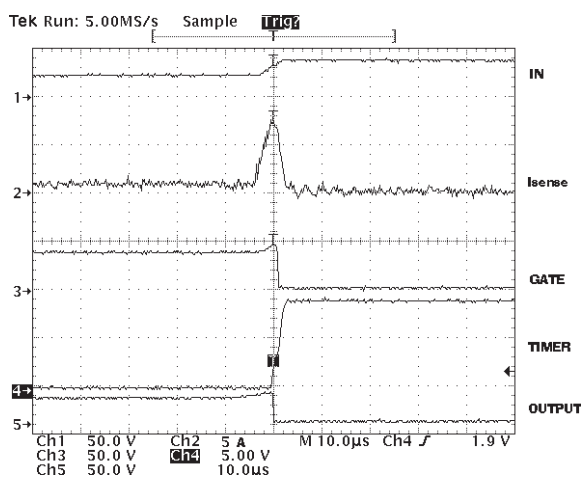

Figure 13. Overvoltage Waveforms

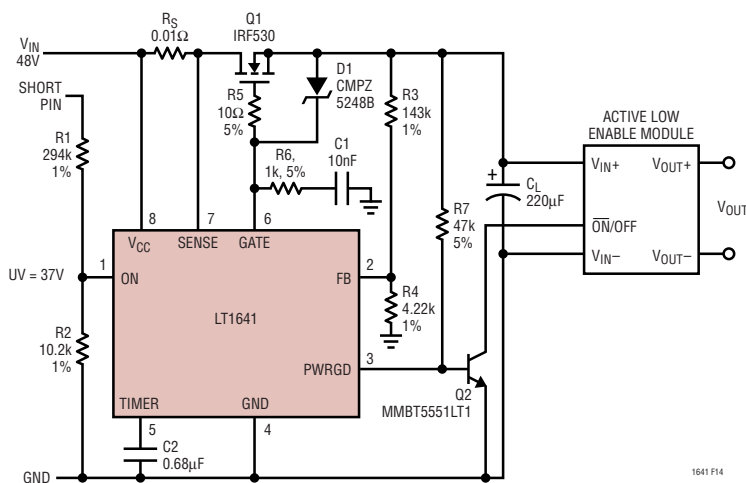

Figure 14. Active Low Enable Module

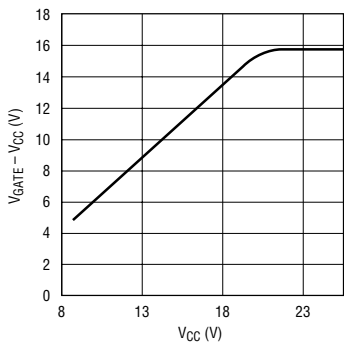

Figure 15. Gate Drive vs Supply Voltage

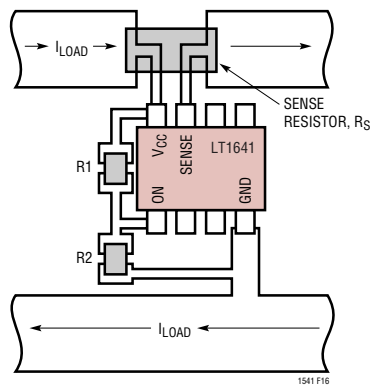
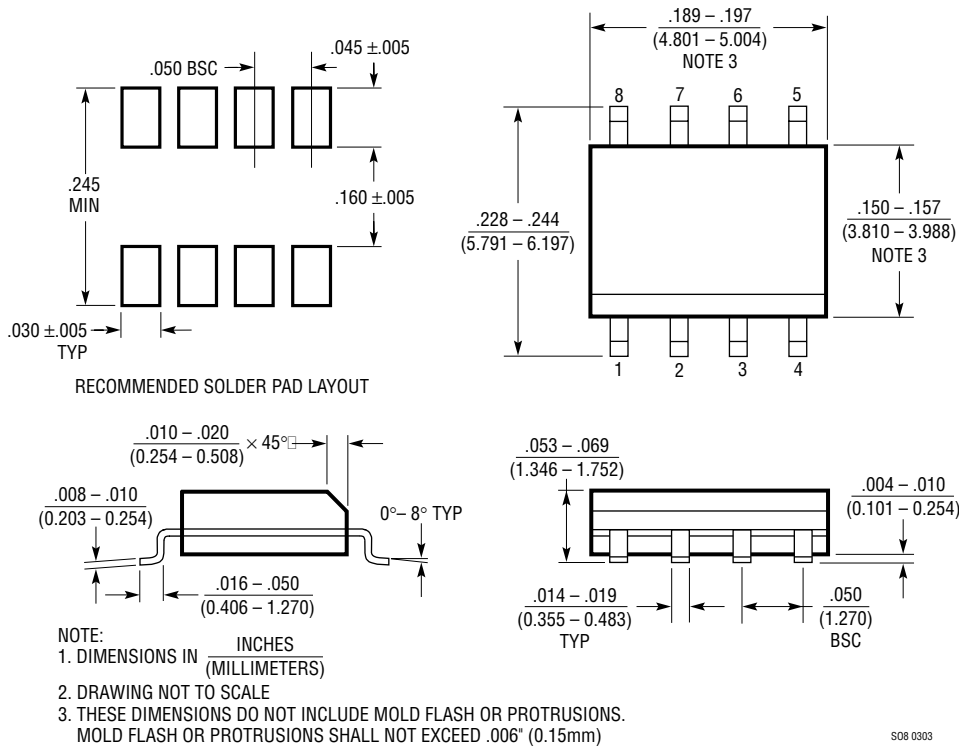

Figure 16. Recommended Layout for R1, R2 and  $R_S$

**PACKAGE DESCRIPTION**

**S8 Package**  
**8-Lead Plastic Small Outline (Narrow .150 Inch)**  
 (Reference LTC DWG # 05-08-1610)



**RELATED PARTS**

PART NUMBER	DESCRIPTION	COMMENTS
LT1640A	Negative High Voltage Hot Swap Controller	Operates from -10V to -80V
LTC1421	Dual Channel Hot Swap Controller	Operates Two Supplies from 3V to 12V and a Third to -12V
LTC1422	High Side Drive Hot Swap Controller in SO-8	System Reset Output with Programmable Delay
LT1641-1/LT1641-2	Positive High Voltage Hot Swap Controller	Pin Compatible for Latched Mode Operation/Automatic Retry
LTC1642	Fault Protected Hot Swap Controller	Operates from 3V to 16.5V, Handles Surges to 33V
LTC1643	PCI Hot Swap Controller	3.3V, 5V, 12V, -12V Supplies for PCI Bus
LT4250	Negative 48V Hot Swap Controller	Active Current Limiting for Supplies from -20V to -80V

## Looking for pricing, stock, or lifecycle information?

Click below to explore more details on WIN SOURCE:

 [View LT1641CS8#PBF on WIN SOURCE](#)

 [Linear Technology](#) Information

## Optimize Your Supply Chain with WIN SOURCE Solutions

-  Global Sourcing Solution
-  Obsolete Management
-  Cost Control Management
-  Shortage Management
-  Alternative Solution
-  Excess Inventory Management