



**THE DATASHEET OF
LT1331CG#TRPBF**



3V RS562 or 5V/3V RS232 Transceiver with One Receiver Active in Shutdown

FEATURES

- RS232 Compatible 3V Operation
- 3V Logic Interface
- ESD Protection Over $\pm 10\text{kV}$
- 120kbaud Operation for $R_L = 3\text{k}$, $C_L = 2500\text{pF}$
- 250kbaud Operation for $R_L = 3\text{k}$, $C_L = 1000\text{pF}$
- One Low Power Receiver Remains Active While in Shutdown
- 60 μA Supply Current in Shutdown
- Low Power Driver Disable Mode
- Uses Small Capacitors: 0.1 μF , 0.2 μF
- CMOS Comparable Low Power: 60mW
- Easy PC Layout: Flowthrough Architecture
- Rugged Bipolar Design
- Outputs Assume a High Impedance State When Off or Powered Down

APPLICATIONS

- Notebook Computers
- Palmtop Computers

DESCRIPTION

The LT[®]1331 is a 3-driver, 5-receiver RS232 transceiver designed for 3V and mixed 3V/5V systems. Receivers operate from 3V logic supply V_L , while the onboard charge pump and drivers operate from 5V or 3V supply V_{CC} .

The transceiver has two shutdown modes. One mode disables the drivers and the charge pump, the other shuts down all circuitry except for one low power receiver which can be used for ring detection. The V_{CC} supply may be shut down while in ring detection mode. While shut down, the drivers and receivers assume high impedance output states.

The LT1331 is fully compliant with all EIA-RS232 specifications when $V_{CC} = 5\text{V}$. If $V_{CC} = 3\text{V}$, output drive levels are compatible with all known interface circuits. Special bipolar construction techniques protect the drivers and receivers beyond the fault conditions stipulated for RS232. The RS232 I/O pins are resilient to multiple $\pm 10\text{kV}$ ESD strikes. An advanced driver output stage operates up to 120kbaud while driving heavy capacitive loads.

LT, LTC and LT are registered trademarks of Linear Technology Corporation.

TYPICAL APPLICATION

3.3V Operation

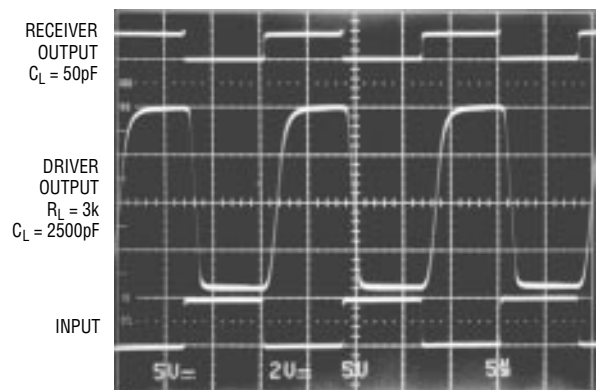
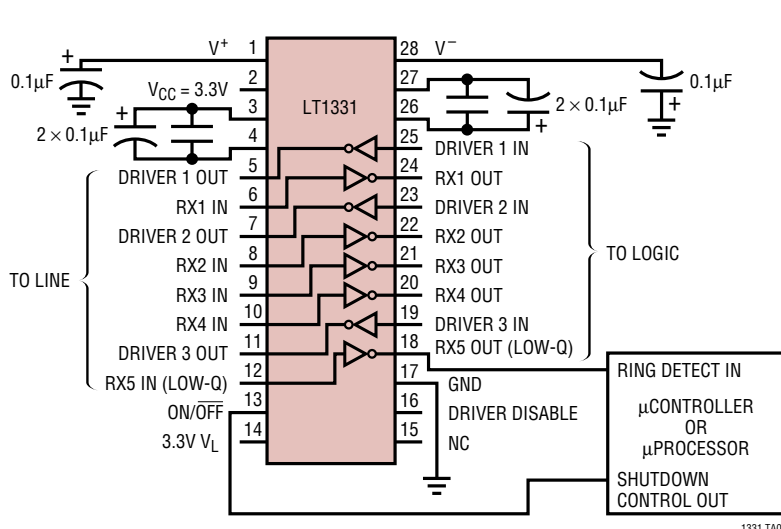

1331 TA02

1331 TA01

ABSOLUTE MAXIMUM RATINGS

(Note 1)

Supply Voltage (V_{CC})	6V
Supply Voltage (V_L)	6V
V^+	13.2V
V^-	-13.2V
Input Voltage	
Driver	V^+ to V^-
Receiver	30V to -30V
ON/OFF	-0.3V to $V_{CC} + 0.3V$
DRIVER DISABLE	-0.3V to $V_{CC} + 0.3V$
Output Voltage	
Driver	-30V to 30V
Receiver	-0.3V to $V_L + 0.3V$
Short Circuit Duration	
V^+	30 sec
V^-	30 sec
Driver Output	Indefinite
Receiver Output	Indefinite
Operating Temperature Range	0°C to 70°C
Storage Temperature Range	-65°C to 150°C
Lead Temperature (Soldering, 10 sec)	300°C

PACKAGE/ORDER INFORMATION

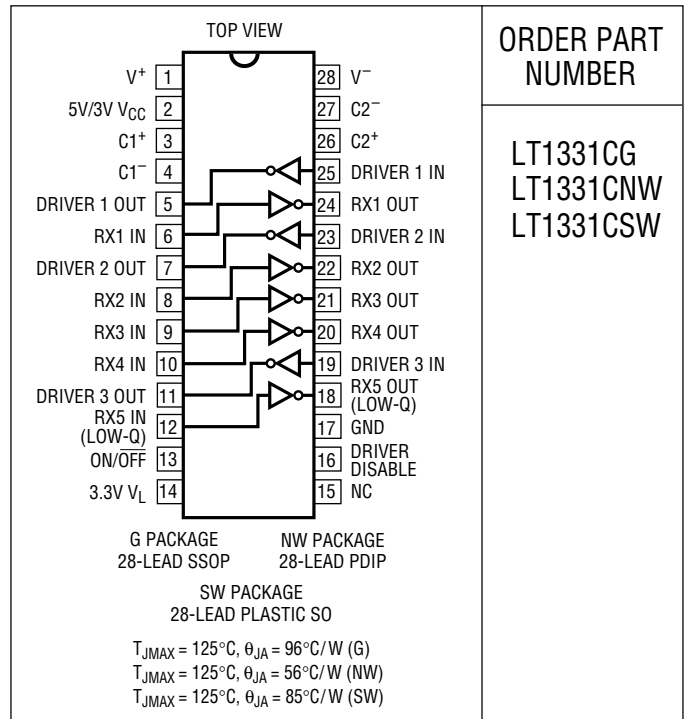

ORDER PART NUMBER

LT1331CG
LT1331CNW
LT1331CSW

Consult factory for Industrial and Military grade parts.

ELECTRICAL CHARACTERISTICS (Note 2)

PARAMETER	CONDITIONS	MIN	TYP	MAX	UNITS
Power Supply Generator					
V^+ Output	$V_{CC} = 5V$ $V_{CC} = 3.3V$		8.6 5.5		V
V^- Output	$V_{CC} = 5V$ $V_{CC} = 3.3V$		-7.0 -4.8		V
Supply Current (V_{CC})	$V_{CC} = 5V$ (Note 3) $V_{CC} = 3.3V$	●	12 12	17 17	mA
Supply Current (V_L)	(Note 4)	●	3	5	mA
Supply Current When OFF (V_{CC})	Shutdown (Note 5) Driver Disable	●	2 0.1	50 1	μA mA
Supply Current When OFF (V_L)	Shutdown (Note 5) Driver Disable	●	60 3	100 5	μA mA
Supply Rise Time, Shutdown to Turn-On	$C1 = C2 = 0.2\mu F, C^+ = C^- = 0.1\mu F$		0.2		ms
ON/OFF Pin Thresholds	Input Low Level (Device Shut Down) Input High Level (Device Enabled)	●	1.4 2.4	0.8	V
ON/OFF Pin Current	$0V \leq V_{ON/OFF} \leq 5V$	●	-15	80	μA
DRIVER DISABLE Pin Thresholds	Input Low Level (Drivers Enabled) Input High Level (Drivers Disabled)	●	1.4 2.4	0.8	V
DRIVER DISABLE Pin Current	$0V \leq V_{DRIVER\ DISABLE} \leq 5V$	●	-10	500	μA
Oscillator Frequency			130		kHz

ELECTRICAL CHARACTERISTICS

PARAMETER	CONDITIONS		MIN	TYP	MAX	UNITS
Any Driver						
Output Voltage Swing, Positive	$V_{CC} = 5V, R_L = 3k$ $V_{CC} = 3.3V, R_L = 3k$	●	5.0 3.7	6.5 4.0		V V
Output Voltage Swing, Negative	$V_{CC} = 5V, R_L = 3k$ $V_{CC} = 3.3V, R_L = 3k$	●		-6.0 -3.3	-5.0 -2.7	V V
Logic Input Voltage Level	Input Low Level ($V_{OUT} = \text{High}$) Input High Level ($V_{OUT} = \text{Low}$)	● ●	2.0	1.4 1.4	0.8	V V
Logic Input Current	$0.8V \leq V_{IN} \leq 2V$	●		5	20	μA
Output Short-Circuit Current	$V_{OUT} = 0V$		± 9	17		mA
Output Leakage Current	Shutdown $V_{OUT} = \pm 30V$ (Note 5)	●		10	100	μA
Data Rate (Note 8)	$R_L = 3k, C_L = 2500\text{pF}$ $R_L = 3k, C_L = 1000\text{pF}$		120 250			kBaud kBaud
Slew Rate	$R_L = 3k, C_L = 51\text{pF}$ $R_L = 3k, C_L = 2500\text{pF}$			15 6	30	V/ μs V/ μs
Propagation Delay	Output Transition t_{HL} High to Low (Note 6) Output Transition t_{LH} Low to High			0.6 0.5	1.3 1.3	μs μs
Any Receiver						
Input Voltage Thresholds	Input Low Threshold ($V_{OUT} = \text{High}$) Input High Threshold ($V_{OUT} = \text{Low}$)	● ●	0.8	1.3 1.7	2.4	V V
Hysteresis		●	0.1	0.4	1.0	V
Input Resistance	$V_{IN} = \pm 10V$		3	5	7	k Ω
Receivers 1 Through 4						
Output Voltage	Output Low, $I_{OUT} = -1.6\text{mA}$ Output High, $I_{OUT} = 160\mu\text{A}$ ($V_L = 3.3V$)	● ●	2.0	0.2 2.4	0.4	V V
Output Short-Circuit Current	Sinking Current, $V_{OUT} = V_{CC}$ Sourcing Current, $V_{OUT} = 0V$		10	-20 20	-10	mA mA
Propagation Delay	Output Transition t_{HL} High to Low (Note 7) Output Transition t_{LH} Low to High			250 350	600 600	ns ns
Output Leakage Current	Shutdown (Note 5) $0 \leq V_{OUT} \leq V_{CC}$	●		1	10	μA
Receiver 5 (Low Q-Current RX)						
Output Voltage	Output Low, $I_{OUT} = -500\mu\text{A}$ Output High, $I_{OUT} = 160\mu\text{A}$ ($V_L = 3V$)	● ●	2.0	0.2 2.4	0.4	V V
Output Short-Circuit Current	Sinking Current, $V_{OUT} = V_{CC}$ Sourcing Current, $V_{OUT} = 0V$		2	-4 4	-2	mA mA
Propagation Delay	Output Transition t_{HL} High to Low (Note 7) Output Transition t_{LH} Low to High			1 1	3 3	μs μs

The ● denotes specifications which apply over the full operating temperature range ($0^\circ\text{C} \leq T_A \leq 70^\circ\text{C}$ for commercial grade).

Note 1: Absolute Maximum Ratings are those values beyond which the life of a device may be impaired.

Note 2: Testing done at $V_{CC} = 5V$, $V_L = 3.3V$, and $V_{ON/OFF} = 3V$, unless otherwise stated.

Note 3: Supply current is measured as the average over several charge pump cycles. $C^+ = 1\mu\text{F}$, $C^- = 0.1\mu\text{F}$, $C1 = C2 = 0.2\mu\text{F}$. All outputs are open with all driver inputs tied high.

Note 4: V_L supply current is measured with all receiver outputs high.

Note 5: Supply current and leakage current measurements in shutdown are performed with $V_{ON/OFF} \leq 0.1V$. Supply current measurements using driver disable are performed with $V_{DRIVER\ DISABLE} \geq 3V$.

Note 6: For driver delay measurements, $R_L = 3k$ and $C_L = 51\text{pF}$. Trigger points are set between the driver's input logic threshold and the output transition to the zero crossing ($t_{HL} = 1.4V$ to $0V$ and $t_{LH} = 1.4V$ to $0V$).

Note 7: For receiver delay measurements, $C_L = 51\text{pF}$. Trigger points are set between the receiver's input logic threshold and the output transition to standard TTL/CMOS logic threshold ($t_{HL} = 1.3V$ to $2.0V$ and $t_{LH} = 1.7V$ to $0.8V$).

Note 8: Data rate operation guaranteed by slew rate, short-circuit current and propagation delay tests.

TYPICAL PERFORMANCE CHARACTERISTICS

Driver Short-Circuit Current

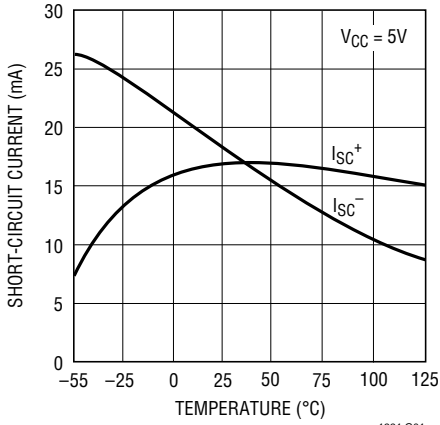

1331 G01

Driver Output Voltage

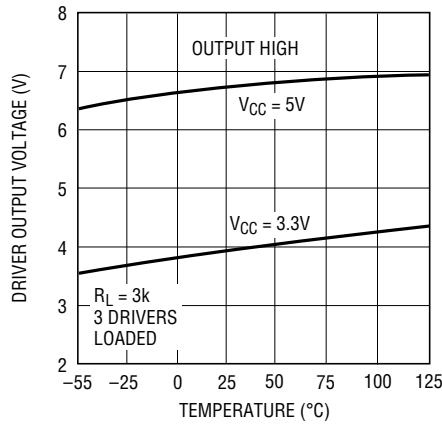

1331 G02

Driver Output Voltage

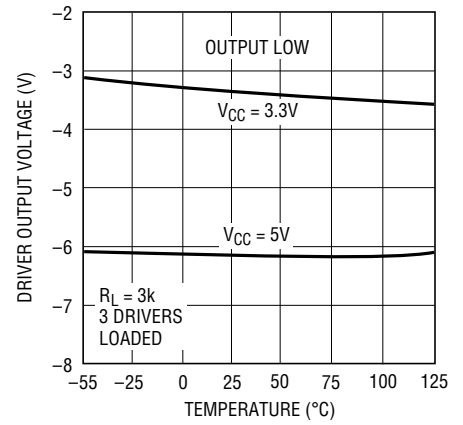

1331 G03

Driver Leakage in Shutdown

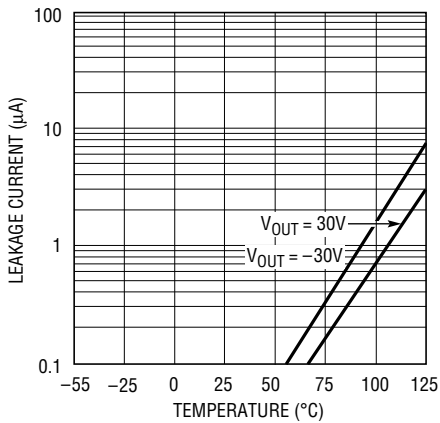

1331 G04

Slew Rate vs Load Capacitance

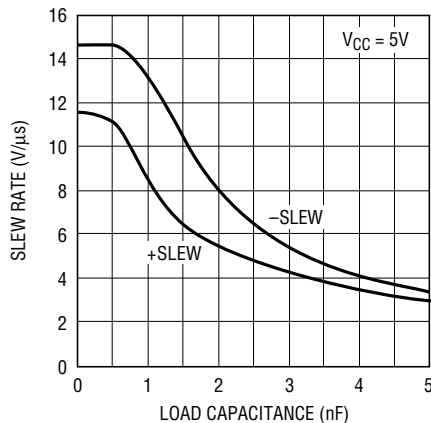

1331 G05

Slew Rate vs Load Capacitance

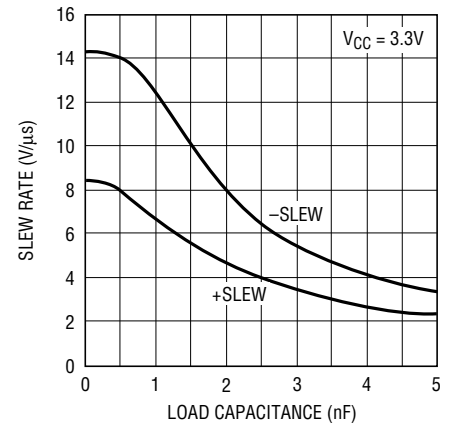

1331 G06

Supply Current vs Data Rate

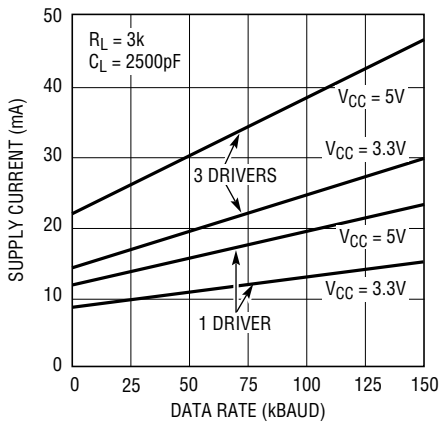

1331 G07

Receiver Input Thresholds

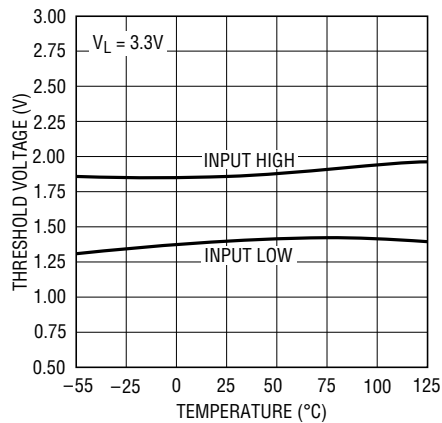

1331 G08

Receiver Short-Circuit Current

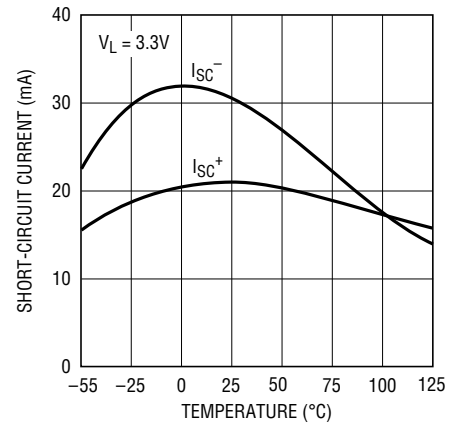

1331 G09

PIN FUNCTIONS

V⁺ (Pin 1): Positive Supply Output. $V^+ \cong 2V_{CC} - 1.5V$. This pin requires an external capacitor for charge storage, chosen to minimize ripple to acceptable levels. A minimum size of 0.1 μ F is recommended.

V_{CC} (Pin 2): Power Supply for Charge Pump and Drivers. Proper circuit operation is insured for $V_{CC} = 3V$ to 6V. $V_{CC} = 5V$ operation gives full RS232 compliant performance, 3V operation results in lower driver output amplitude. The V_{CC} pin should be decoupled with a 0.1 μ F ceramic capacitor.

C1⁺, C1⁻, C2⁺, C2⁻ (Pins 3, 4, 26, 27): These pins require two external capacitors $C \geq 0.2\mu F$. One from C1⁺ to C1⁻, and another from C2⁺ to C2⁻. To maintain charge pump efficiency, the capacitor's effective series resistance should be less than 2 Ω . Low ESR tantalum capacitors work well in this application, small value ceramic capacitors may also be used with minimal reduction in charge pump compliance.

DRIVER OUT (Pins 5, 7, 11): RS232 Driver Outputs. Outputs are in a high impedance state when in shutdown, driver disable, or $V_{CC} = 0V$. Outputs are fully short-circuit protected from $V^- + 30V$ to $V^+ - 30V$. Although the outputs are protected, short circuits on one output can load the power supply generator and may disrupt the signal levels of the other outputs. The driver outputs are protected against ESD to $\pm 10kV$ for human body model discharges. Output levels of $-3.3V$ to 4V are achieved when the circuit is operated with $V_{CC} = 3.3V$.

RX IN (Pins 6, 8, 9, 10): Receiver Inputs with 0.4V of Hysteresis for Noise Immunity. These pins accept RS232 level signals ($\pm 30V$) into a protected 5k terminating resistor. The receiver inputs are protected against ESD to $\pm 10kV$ for human body model discharges.

LOW-Q RX IN (Pin 12): Low Power Receiver Input. This receiver remains active in shutdown mode, consuming only 60 μ A from supply V_L . This receiver has the same input and protection characteristics as receivers RX1 through RX4.

ON/OFF (Pin 13): A TTL/CMOS Compatible Operating Mode Control. A logic low puts the device in the shutdown mode. All drivers and four of the receivers go to a high impedance state, and the V_{CC} supply may be turned off. A logic high fully enables the transceiver.

V_L (Pin 14): Power Supply for Receivers. This pin should be powered to the same voltage as the logic circuits connected to the receiver outputs, either 5V or 3V. The V_L pin should be decoupled with a 0.1 μ F ceramic capacitor.

DRIVER DISABLE (Pin 16): A logic high shuts down the charge pump, placing all drivers in a high impedance state. All receivers remain active. Floating the pin, or driving it to a logic low, fully enables the transceiver. A low voltage on the ON/OFF pin supersedes the state of the driver disable control.

GND (Pin 17): Ground.

LOW-Q RX OUT (Pin 18): Low Power Receiver Output. This pin produces the same output levels as standard receivers, with slightly decreased speed and short-circuit current.

DRIVER IN (Pins 19, 23, 25): RS232 Driver Inputs. Inputs are TTL/CMOS compatible. Tie unused inputs to V_{CC} .

RX OUT (Pins 20, 21, 22, 24): Receiver Outputs. RX1 through RX4 outputs are in a high impedance state when in shutdown mode to allow data line sharing. Outputs, including LOW-Q RX OUT, are fully short-circuit protected to ground, V_{CC} , or V_L . Output voltage levels are determined by the choice of power supply V_L .

V⁻ (Pin 28): Negative Supply Output. $V^- \cong -(2V_{CC} - 2.5V)$. This pin requires an external charge storage capacitor, chosen to minimize ripple on V^- . A minimum value of 0.1 μ F is recommended.

APPLICATIONS INFORMATION

Power Saving Operational Modes

The LT1331 has both shutdown and driver disable operating modes. These operating modes can optimize power consumption based upon applications needs.

The shutdown control turns off all circuitry except for Low-Q RX5. RX5 operates entirely from the V_L power supply, so the power consumption from V_{CC} drops to zero. The V_{CC} power supply may be turned off while in shutdown, which may allow greater power savings in some systems. When RX5 detects a signal, this information can be used to wake up the system for full operation.

If more than one line must be monitored, the driver disable mode provides a power efficient operating option. The driver disable mode turns off the charge pumps and RS232 drivers, but keeps all five receivers active. Power consumption in driver disable mode is 3mA from V_L and less than 100 μ A from V_{CC} .

Mixed 5V/3V Operation

When operated with $V_{CC} = 5V$ and $V_L = 3.3V$ supplies, the RS232 drivers meet or exceed all RS232 or V.28 communication interface standards. Data rates up to 120kbaud are supported, and all standard RS232 compatible mice may be driven by the LT1331.

3V Operation

$V_{CC} = 3.3V$ operation of the LT1331 results in lower driver output swing than with $V_{CC} = 5V$. The driver output swing, when operated with $V_{CC} = 3.3V$, is guaranteed to be at least $-2.7V$ to $3.7V$, with typical swing being $-3.3V$ to $4V$. This insures compatibility with all commonly used RS232 and RS562 interface circuits. Table 1 summarizes the receiver input threshold specifications for RS232 circuits from many manufacturers.

Table 1. Commonly Used RS232 Interface Circuit Receiver Thresholds

MANUFACTURER	PART NUMBER	COMPATIBLE	INPUT LOW THRESHOLD			INPUT HIGH THRESHOLD		
			MIN	TYP	MAX	MIN	TYP	MAX
Linear Technology	LT1080	✓	0.8	1.3	–	–	1.7	2.4
	LT1137A	✓	0.8	1.3	–	–	1.7	2.4
	LT1330	✓	0.8	1.3	–	–	1.7	2.4
	LT1281	✓	0.8	1.3	–	–	1.7	2.4
	All Others	✓						
Texas Instruments	SN75189	✓	0.65	1.0	1.25	0.9	1.3	1.6
	SN75189A	✓	0.65	1.0	1.25	1.55	1.9	2.25
	MAX232	✓	0.8	1.2	–	–	1.7	2.4
	SN75C185	✓	0.65	1.0	1.25	1.6	2.1	2.55
Maxim	MAX232A	✓	0.8	1.3	–	–	1.8	2.4
	MAX241	✓	0.6	1.2	–	–	1.5	2.4
Sipex	SP232	✓	0.8	1.2	–	–	1.7	2.4
	SP301	✓	0.75	–	1.35	1.75	–	2.5
Motorola	MC1489	✓	0.75	–	1.25	1.0	–	1.5
	MC1489A	✓	0.75	0.8	1.25	1.75	1.95	2.25
National	DS1489	✓	0.75	1.0	1.25	1.0	1.25	1.5
	DS14C89A	✓	0.5	–	1.9	1.3	–	2.7

ESD PROTECTION

The RS232 line inputs of the LT1331 have on-chip protection from ESD transients up to $\pm 10\text{kV}$. The protection structures act to divert the static discharge safely to system ground. In order for the ESD protection to function effectively, the power supply and ground pins of the LT1331 must be connected to ground through low impedances. The power supply decoupling capacitors and charge pump storage capacitors provide this low impedance in normal application of the circuit. The only constraint is that low ESR capacitors must be used for bypassing and charge storage. ESD testing must be done with pins V_{CC} , V_L , V^+ , V^- and GND shorted to ground or connected with low ESR capacitors.

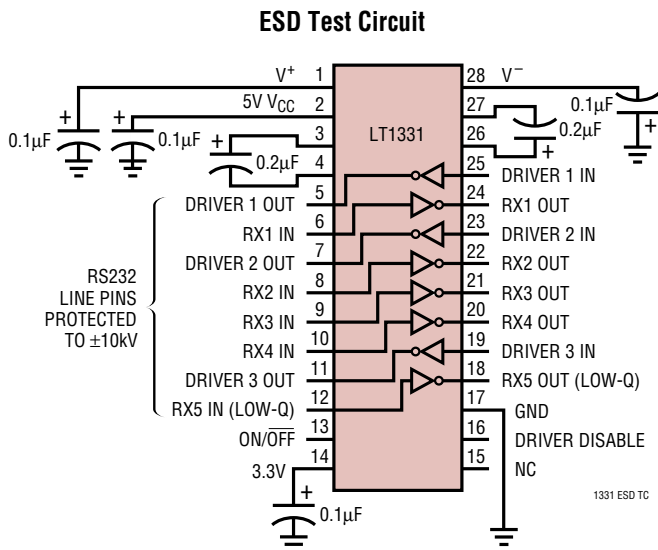

PACKAGE DESCRIPTION Dimensions in inches (millimeters) unless otherwise noted.

G Package 28-Lead Plastic SSOP (0.209) (LTC DWG # 05-08-1640)

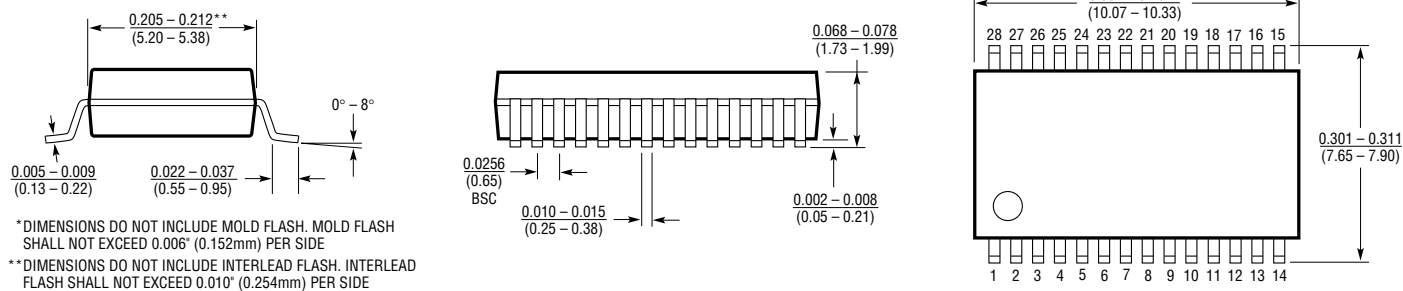

NW Package 28-Lead PDIP (Wide 0.600) (LTC DWG # 05-08-1520)

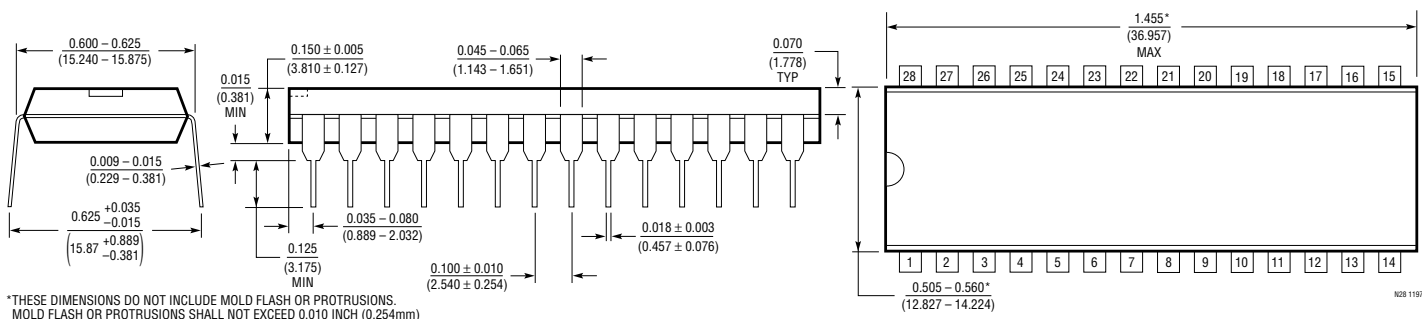

PACKAGE DESCRIPTION Dimensions in inches (millimeters) unless otherwise noted.

SW Package
28-Lead Plastic Small Outline (Wide 0.300)
 (LTC DWG # 05-08-1620)

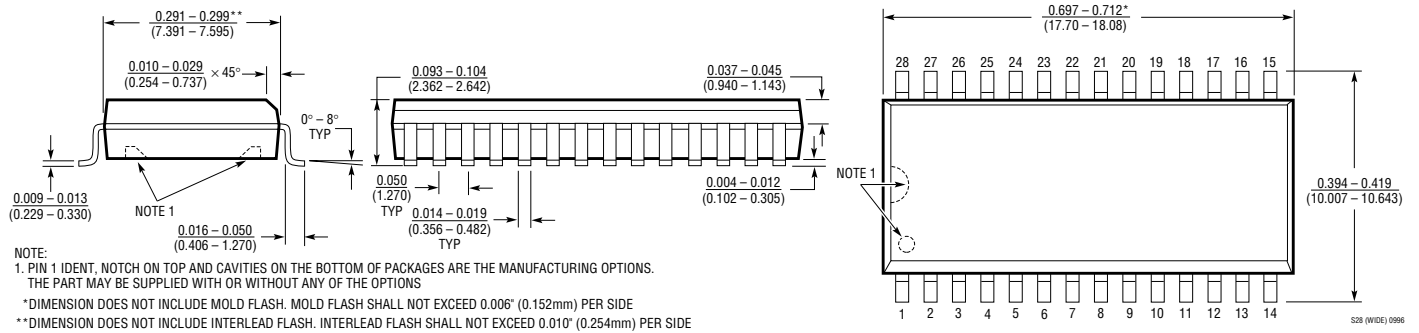

TYPICAL APPLICATION

Mixed 5V/3V Supply Operation

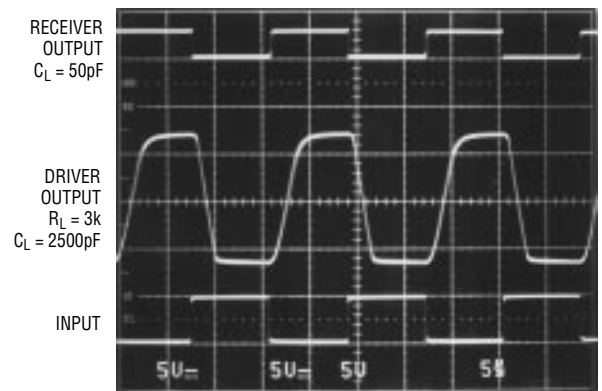
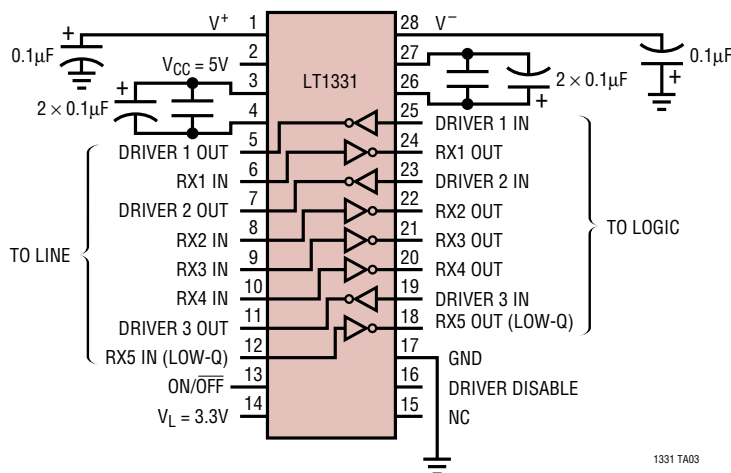

RELATED PARTS

PART NUMBER	DESCRIPTION	COMMENTS
LT1130A/LT1140A	5V RS232 Transceivers with Small Capacitors	10kV ESD
LT1137A	3-DR/5-RX RS232 Transceiver	15kV ESD
LTC1349	5V Low Power, 3-DR/5-RX RS232 Transceiver	2 RXs Active in Shutdown
LTC1385	3.3V Low Power EIA/TIA-562 Transceiver	
LT1780/LT1781	2-DR/2-RX RS232 Transceivers	15kV ESD

Looking for pricing, stock, or lifecycle information?

Click below to explore more details on WIN SOURCE:

 [View LT1331CG#TRPBF on WIN SOURCE](#)

 [Linear Technology](#) Information

Optimize Your Supply Chain with WIN SOURCE Solutions

-  Global Sourcing Solution
-  Obsolete Management
-  Cost Control Management
-  Shortage Management
-  Alternative Solution
-  Excess Inventory Management