



**THE DATASHEET OF  
LT1113CS8#PBF**



## FEATURES

- 100% Tested Low Voltage Noise:  $6\text{nV}/\sqrt{\text{Hz}}$  Max
- SO-8 Package Standard Pinout
- Voltage Gain: 1.2 Million Min
- Offset Voltage: 1.5mV Max
- Offset Voltage Drift:  $15\mu\text{V}/^\circ\text{C}$  Max
- Input Bias Current, Warmed Up: 450pA Max
- Gain Bandwidth Product: 5.6MHz Typ
- Guaranteed Specifications with  $\pm 5\text{V}$  Supplies
- Guaranteed Matching Specifications

## APPLICATIONS

- Photocurrent Amplifiers
- Hydrophone Amplifiers
- High Sensitivity Piezoelectric Accelerometers
- Low Voltage and Current Noise Instrumentation Amplifier Front Ends
- Two and Three Op Amp Instrumentation Amplifiers
- Active Filters

## DESCRIPTION

The **LT<sup>®</sup>1113** achieves a new standard of excellence in noise performance for a dual JFET op amp. The  $4.5\text{nV}/\sqrt{\text{Hz}}$  1kHz noise combined with low current noise and picoampere bias currents makes the LT1113 an ideal choice for amplifying low level signals from high impedance capacitive transducers.

The LT1113 is unconditionally stable for gains of 1 or more, even with load capacitances up to 1000pF. Other key features are 0.4mV  $V_{OS}$  and a voltage gain of 4 million. Each individual amplifier is 100% tested for voltage noise, slew rate and gain bandwidth.

The design of the LT1113 has been optimized to achieve true precision performance with an industry standard pinout in the SO-8 package. A set of specifications are provided for  $\pm 5\text{V}$  supplies and a full set of matching specifications are provided to facilitate the use of the LT1113 in matching dependent applications such as instrumentation amplifier front ends.

**LT**, **LT**, **LTC**, **LTM**, Linear Technology and the Linear logo are registered trademarks and C-Load is a trademark of Linear Technology Corporation. All other trademarks are the property of their respective owners.

## TYPICAL APPLICATION

Low Noise Hydrophone Amplifier with DC Servo

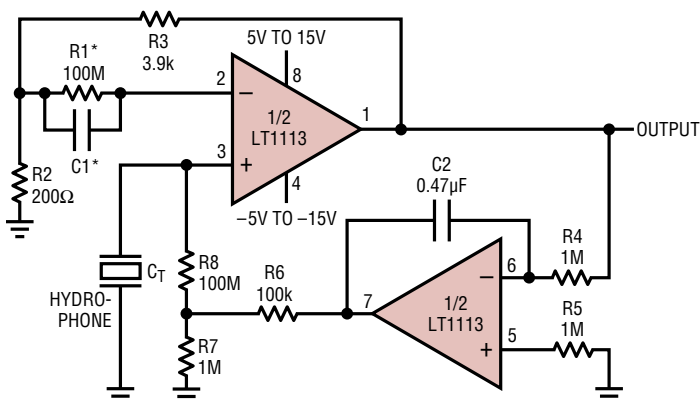

DC OUTPUT  $\leq 2.5\text{mV}$  FOR  $T_A < 70^\circ\text{C}$   
 OUTPUT VOLTAGE NOISE =  $128\text{nV}/\sqrt{\text{Hz}}$  AT 1kHz (GAIN = 20)  
 $C1 \approx C_T \approx 100\text{pF}$  TO  $5000\text{pF}$ ;  $R4C2 > R8C_T$ ; \*OPTIONAL

1113 TA01

1kHz Input Noise Voltage Distribution

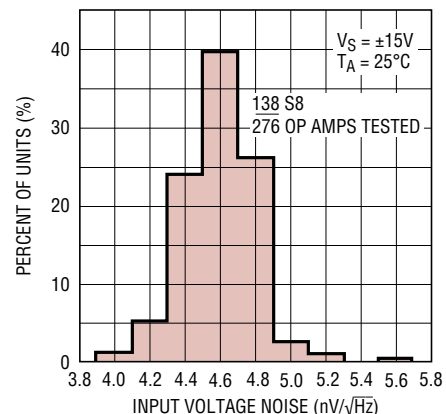

1113 TA02

# LT1113

## ABSOLUTE MAXIMUM RATINGS (Note 1)

Supply Voltage		Operating Temperature Range	
-55°C to 105°C.....	±20V	LT1113AC/LT1113C (Note 2).....	-40°C to 85°C
105°C to 125°C.....	±16V	LT1113AM/LT1113M ( <b>OBSELETE</b> )	-55°C to 125°C
Differential Input Voltage.....	±40V	Specified Temperature Range	
Input Voltage (Equal to Supply Voltage).....	±20V	LT1113AC/LT1113C (Note 3).....	-40°C to 85°C
Output Short Circuit Duration.....	1 Minute	LT1113AM/LT1113M ( <b>OBSELETE</b> )	-55°C to 125°C
Storage Temperature Range.....	-65°C to 150°C	Lead Temperature (Soldering, 10 sec).....	300°C

## PIN CONFIGURATION

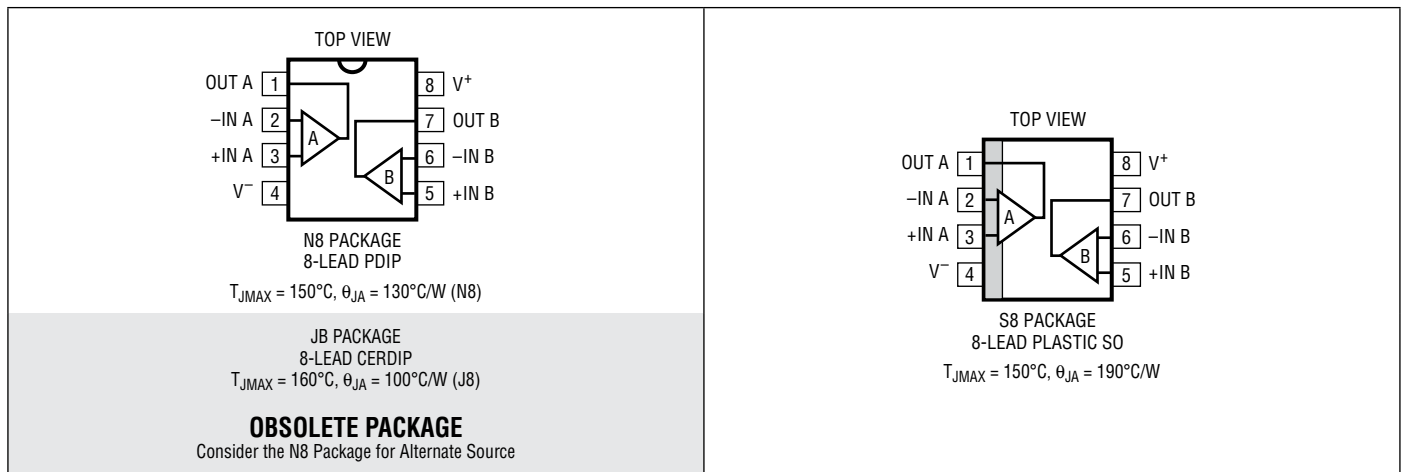

## ORDER INFORMATION

LEAD FREE FINISH	TAPE AND REEL	PART MARKING	PACKAGE DESCRIPTION	TEMPERATURE RANGE
LT1113ACN8#PBF	LT1113ACN8#TRPBF	1113ACN8	8-Lead PDIP	-40°C to 85°C
LT1113CN8#PBF	LT1113CN8#TRPBF	1113CN8	8-Lead PDIP	-40°C to 85°C
LT1113ACS8#PBF	LT1113CS8#TRPBF	1113	8-Lead Plastic SO	-40°C to 85°C
OBSELETE PACKAGE				
LT1113AMJ8#PBF	LT1113AMJ8#TRPBF	1113AMJ8	8-Lead CERDIP	-55°C to 125°C
LT1113MJ8#PBF	LT1113MJ8#TRPBF	1113MJ8	8-Lead CERDIP	-55°C to 125°C

Consult LTC Marketing for parts specified with wider operating temperature ranges.  
Consult LTC Marketing for information on nonstandard lead based finish parts.

For more information on lead free part markings, go to: <http://www.linear.com/leadfree/>  
For more information on tape and reel specifications, go to: <http://www.linear.com/tapeandreeel/>

**ELECTRICAL CHARACTERISTICS**  $V_S = \pm 15V$ ,  $V_{CM} = 0V$ ,  $T_A = 25^\circ C$ , unless otherwise noted.

SYMBOL	PARAMETER	CONDITIONS (Note 4)	LT1113AM/AC			LT1113M/C			UNITS
			MIN	TYP	MAX	MIN	TYP	MAX	
$V_{OS}$	Input Offset Voltage	$V_S = \pm 5V$		0.40	1.5		0.50	1.8	mV
				0.45	1.7		0.55	2.0	mV
$I_{OS}$	Input Offset Current	Warmed Up (Note 5)		30	100		35	150	pA
$I_B$	Input Bias Current	Warmed Up (Note 5)		300	450		320	480	pA
$e_n$	Input Noise Voltage	0.1Hz to 10Hz		2.4			2.4		$\mu V_{P-P}$
	Input Noise Voltage Density	$f_0 = 10Hz$ $f_0 = 1000Hz$		17 4.5	6.0		17 4.5	6.0	$nV/\sqrt{Hz}$ $nV/\sqrt{Hz}$
$i_n$	Input Noise Current Density	$f_0 = 10Hz$ , $f_0 = 1000Hz$ (Note 6)		10			10		$fA/\sqrt{Hz}$
$R_{IN}$	Input Resistance Differential Mode Common Mode	$V_{CM} = -10V$ to $8V$ $V_{CM} = 8V$ to $11V$		$10^{11}$			$10^{11}$		$\Omega$
				$10^{11}$			$10^{11}$		$\Omega$
				$10^{10}$			$10^{10}$		$\Omega$
$C_{IN}$	Input Capacitance	$V_S = \pm 5V$		14			14		pF
				27			27		pF
$V_{CM}$	Input Voltage Range (Note 7)		13.0	13.5		13.0	13.5		V
			-10.5	-11.0		-10.5	-11.0		V
CMRR	Common Mode Rejection Ratio	$V_{CM} = -10V$ to $13V$	85	98		82	95		dB

$V_S = \pm 15V$ ,  $V_{CM} = 0V$ ,  $T_A = 25^\circ C$ , unless otherwise noted.

SYMBOL	PARAMETER	CONDITIONS	LT1113AM/AC			LT1113M/C			UNITS
			MIN	TYP	MAX	MIN	TYP	MAX	
PSRR	Power Supply Rejection Ratio	$V_S = \pm 4.5V$ to $\pm 20V$	86	100		83	98		dB
$A_{VOL}$	Large-Signal Voltage Gain	$V_O = \pm 12V$ , $R_L = 10k$	1200	4800		1000	4500		V/mV
		$V_O = \pm 10V$ , $R_L = 1k$	600	4000		500	3000		V/mV
$V_{OUT}$	Output Voltage Swing	$R_L = 10k$	$\pm 13.5$	$\pm 13.8$		$\pm 13.0$	$\pm 13.8$		V
		$R_L = 1k$	$\pm 12.0$	$\pm 13.0$		$\pm 11.5$	$\pm 13.0$		V
SR	Slew Rate	$R_L \geq 2k$ (Note 9)	2.3	3.9		2.3	3.9		V/ $\mu s$
GBW	Gain Bandwidth Product	$f_0 = 100kHz$	4.0	5.6		4.0	5.6		MHz
$t_s$	Settling Time	0.01%, $A_V = +1$ , $R_L = 1k$ , $C_L \leq 1000pF$ , 10V Step		4.2			4.2		$\mu s$
	Channel Separation	$f_0 = 10Hz$ , $V_O = \pm 10V$ , $R_L = 1k$		130			126		dB
$I_S$	Supply Current per Amplifier			5.3	6.25		5.3	6.50	mA
		$V_S = \pm 5V$		5.3	6.20		5.3	6.45	mA
$\Delta V_{OS}$	Offset Voltage Match			0.8	2.5		0.8	3.3	mV
$\Delta I_B^+$	Noninverting Bias Current Match	Warmed Up (Note 5)		10	80		10	120	pA
$\Delta CMRR$	Common Mode Rejection Match	(Note 11)	81	94		78	94		dB
$\Delta PSRR$	Power Supply Rejection Match	(Note 11)	82	95		80	95		dB

## ELECTRICAL CHARACTERISTICS

The ● denotes specifications which apply over the temperature range  $0^{\circ}\text{C} \leq T_A \leq 70^{\circ}\text{C}$ .  $V_S = \pm 15\text{V}$ ,  $V_{CM} = 0\text{V}$ , unless otherwise noted. (Note 12)

SYMBOL	PARAMETER	CONDITIONS (Note 4)	LT1113AC			LT1113C			UNITS
			MIN	TYP	MAX	MIN	TYP	MAX	
$V_{OS}$	Input Offset Voltage	$V_S = \pm 5\text{V}$	●	0.6	2.1	0.7	2.5	mV	
			●	0.7	2.3	0.8	2.7	mV	
$\frac{\Delta V_{OS}}{\Delta \text{Temp}}$	Average Input Offset Voltage Drift	(Note 8)	●	7	15	8	20	$\mu\text{V}/^{\circ}\text{C}$	
$I_{OS}$	Input Offset Current		●	50	350	55	450	pA	
$I_B$	Input Bias Current		●	600	1200	700	1600	pA	
$V_{CM}$	Input Voltage Range		●	12.9	13.4	12.9	13.4	V	
			●	-10.0	-10.8	-10.0	-10.8	V	
CMRR	Common Mode Rejection Ratio	$V_{CM} = -10\text{V}$ to $12.9\text{V}$	●	81	97	79	94	dB	
PSRR	Power Supply Rejection Ratio	$V_S = \pm 4.5\text{V}$ to $\pm 20\text{V}$	●	83	99	81	97	dB	
$A_{VOL}$	Large-Signal Voltage Gain	$V_O = \pm 12\text{V}$ , $R_L = 10\text{k}$ $V_O = \pm 10\text{V}$ , $R_L = 1\text{k}$	●	900	3600	800	3400	V/mV	
			●	500	2600	400	2400	V/mV	
$V_{OUT}$	Output Voltage Swing	$R_L = 10\text{k}$ $R_L = 1\text{k}$	●	$\pm 13.2$	$\pm 13.5$	$\pm 12.7$	$\pm 13.5$	V	
			●	$\pm 11.7$	$\pm 12.7$	$\pm 11.3$	$\pm 12.7$	V	
SR	Slew Rate	$R_L \geq 2\text{k}$ (Note 9)	●	2.1	3.7	1.7	3.7	V/ $\mu\text{s}$	
GBW	Gain Bandwidth Product	$f_0 = 100\text{kHz}$	●	3.2	4.5	3.2	4.5	MHz	
$I_S$	Supply Current per Amplifier	$V_S = \pm 5\text{V}$	●	5.3	6.35	5.3	6.55	mA	
			●	5.3	6.30	5.3	6.50	mA	
$\Delta V_{OS}$	Offset Voltage Match		●	0.9	3.5	0.9	4.5	mV	
$\Delta I_B^+$	Noninverting Bias Current Match		●	30	300	35	400	pA	
$\Delta \text{CMRR}$	Common Mode Rejection Match	(Note 11)	●	76	93	74	93	dB	
$\Delta \text{PSRR}$	Power Supply Rejection Match	(Note 11)	●	79	93	77	93	dB	

The ● denotes specifications which apply over the temperature range  $-40^{\circ}\text{C} \leq T_A \leq 85^{\circ}\text{C}$ .  $V_S = \pm 15\text{V}$ ,  $V_{CM} = 0\text{V}$ , unless otherwise noted. (Note 10)

SYMBOL	PARAMETER	CONDITIONS (Note 4)	LT1113AC			LT1113C			UNITS
			MIN	TYP	MAX	MIN	TYP	MAX	
$V_{OS}$	Input Offset Voltage	$V_S = \pm 5\text{V}$	●	0.7	2.4	0.8	2.8	mV	
			●	0.8	2.6	0.9	3.0	mV	
$\frac{\Delta V_{OS}}{\Delta \text{Temp}}$	Average Input Offset Voltage Drift		●	7	15	8	20	$\mu\text{V}/^{\circ}\text{C}$	
$I_{OS}$	Input Offset Current		●	80	700	90	1000	pA	
$I_B$	Input Bias Current		●	1750	3000	1800	5000	pA	
$V_{CM}$	Input Voltage Range		●	12.6	13.0	12.6	13.0	V	
			●	-10.0	-10.5	-10.0	-10.5	V	
CMRR	Common Mode Rejection Ratio	$V_{CM} = -10\text{V}$ to $12.6\text{V}$	●	80	96	78	93	dB	
PSRR	Power Supply Rejection Ratio	$V_S = \pm 4.5\text{V}$ to $\pm 20\text{V}$	●	81	98	79	96	dB	
$A_{VOL}$	Large-Signal Voltage Gain	$V_O = \pm 12\text{V}$ , $R_L = 10\text{k}$ $V_O = \pm 10\text{V}$ , $R_L = 1\text{k}$	●	850	3300	750	3000	V/mV	
			●	400	2200	300	2000	V/mV	
$V_{OUT}$	Output Voltage Swing	$R_L = 10\text{k}$ $R_L = 1\text{k}$	●	$\pm 13.0$	$\pm 12.5$	$\pm 12.5$	$\pm 12.5$	V	
			●	$\pm 11.5$	$\pm 12.0$	$\pm 11.0$	$\pm 12.0$	V	
SR	Slew Rate	$R_L \geq 2\text{k}$	●	2.0	3.5	1.6	3.5	V/ $\mu\text{s}$	
GBW	Gain Bandwidth Product	$f_0 = 100\text{kHz}$	●	2.9	4.3	2.9	4.3	MHz	

**ELECTRICAL CHARACTERISTICS** The ● denotes specifications which apply over the temperature range  $-40^{\circ}\text{C} \leq T_A \leq 85^{\circ}\text{C}$ .  $V_S = \pm 15\text{V}$ ,  $V_{CM} = 0\text{V}$ , unless otherwise noted. (Note 10)

SYMBOL	PARAMETER	CONDITIONS (Note 4)	LT1113AC			LT1113C			UNITS
			MIN	TYP	MAX	MIN	TYP	MAX	
$I_S$	Supply Current per Amplifier	$V_S = \pm 5\text{V}$	●	5.30	6.35	5.30	6.55	mA	
			●	5.25	6.30				5.25
$\Delta V_{OS}$	Offset Voltage Match		●	1.0	4.4	1.0	5.1	mV	
$\Delta I_B^+$	Noninverting Bias Current Match		●	50	600	55	900	pA	
$\Delta \text{CMRR}$	Common Mode Rejection Match	(Note 11)	●	76	93	73	93	dB	
$\Delta \text{PSRR}$	Power Supply Rejection Match	(Note 11)	●	77	92	75	92	dB	

The ● denotes specifications which apply over the temperature range  $-55^{\circ}\text{C} \leq T_A \leq 125^{\circ}\text{C}$ .  $V_S = \pm 15\text{V}$ ,  $V_{CM} = 0\text{V}$ , unless otherwise noted. (Note 12)

SYMBOL	PARAMETER	CONDITIONS (Note 4)	LT1113AM			LT1113M			UNITS
			MIN	TYP	MAX	MIN	TYP	MAX	
$V_{OS}$	Input Offset Voltage	$V_S = \pm 5\text{V}$	●	0.8	2.7	0.9	3.3	mV	
			●	0.8	2.8				0.9
$\frac{\Delta V_{OS}}{\Delta \text{Temp}}$	Average Input Offset Voltage Drift	(Note 8)	●	5	12	8	15	$\mu\text{V}/^{\circ}\text{C}$	
$I_{OS}$	Input Offset Current		●	0.8	15	1.0	25	nA	
$I_B$	Input Bias Current		●	25	50	27	70	nA	
$V_{CM}$	Input Voltage Range		●	12.6	13.0	12.6	13.0	V	
			●	-10.0	-10.4				-10.0
$\text{CMRR}$	Common Mode Rejection Ratio	$V_{CM} = -10\text{V}$ to $12.6\text{V}$	●	79	95	77	92	dB	
$\text{PSRR}$	Power Supply Rejection Ratio	$V_S = \pm 4.5\text{V}$ to $\pm 20\text{V}$	●	80	97	78	95	dB	
$A_{VOL}$	Large-Signal Voltage Gain	$V_O = \pm 12\text{V}$ , $R_L = 10\text{k}$ $V_O = \pm 10\text{V}$ , $R_L = 1\text{k}$	●	800	2700	700	2500	V/mV	
			●	400	1500				300
$V_{OUT}$	Output Voltage Swing	$R_L = 10\text{k}$ $R_L = 1\text{k}$	●	$\pm 13.0$	$\pm 12.5$	$\pm 12.5$	$\pm 12.5$	V	
			●	$\pm 11.5$	$\pm 12.0$				$\pm 11.0$
$\text{SR}$	Slew Rate	$R_L \geq 2\text{k}$ (Note 9)	●	1.9	3.3	1.6	3.3	$\text{V}/\mu\text{s}$	
$\text{GBW}$	Gain Bandwidth Product	$f_0 = 100\text{kHz}$	●	2.2	3.4	2.2	3.4	MHz	
$I_S$	Supply Current Per Amplifier	$V_S = \pm 5\text{V}$	●	5.30	6.35	5.30	6.55	mA	
			●	5.25	6.30				5.25
$\Delta V_{OS}$	Offset Voltage Match		●	1.0	5.0	1.0	5.5	mV	
$\Delta I_B^+$	Noninverting Bias Current Match		●	1.8	12	2.0	20	nA	
$\Delta \text{CMRR}$	Common Mode Rejection Match	(Note 11)	●	75	92	73	92	dB	
$\Delta \text{PSRR}$	Power Supply Rejection Match	(Note 11)	●	76	91	74	91	dB	

**Note 1:** Stresses beyond those listed under Absolute Maximum Ratings may cause permanent damage to the device. Exposure to any Absolute Maximum Rating condition for extended periods may affect device reliability and lifetime.

**Note 2:** The LT1113C is guaranteed functional over the Operating Temperature Range of  $-40^{\circ}\text{C}$  to  $85^{\circ}\text{C}$ . The LT1113M is guaranteed functional over the Operating Temperature Range of  $-55^{\circ}\text{C}$  to  $125^{\circ}\text{C}$ .

**Note 3:** The LT1113C is guaranteed to meet specified performance from  $0^{\circ}\text{C}$  to  $70^{\circ}\text{C}$ . The LT1113C is designed, characterized and expected to meet specified performance from  $-40^{\circ}\text{C}$  to  $85^{\circ}\text{C}$  but is not tested or QA sampled at these temperatures. For guaranteed I grade parts, consult the

factory. The LT1113M is guaranteed to meet specified performance from  $-55^{\circ}\text{C}$  to  $125^{\circ}\text{C}$ .

**Note 4:** Typical parameters are defined as the 60% yield of parameter distributions of individual amplifiers, i.e., out of 100 LT1113s (200 op amps) typically 120 op amps will be better than the indicated specification.

**Note 5:** Warmed-up  $I_B$  and  $I_{OS}$  readings are extrapolated to a chip temperature of  $50^{\circ}\text{C}$  from  $25^{\circ}\text{C}$  measurements and  $50^{\circ}\text{C}$  characterization data.

**Note 6:** Current noise is calculated from the formula:

$$i_n = (2qI_B)^{1/2}$$

where  $q = 1.6 \cdot 10^{-19}$  coulomb. The noise of source resistors up to 200M swamps the contribution of current noise.

## ELECTRICAL CHARACTERISTICS

**Note 7:** Input voltage range functionality is assured by testing offset voltage at the input voltage range limits to a maximum of 2.3mV (A grade) to 2.8mV (C grade).

**Note 8:** This parameter is not 100% tested.

**Note 9:** Slew rate is measured in  $A_V = -1$ ; input signal is  $\pm 7.5V$ , output measured at  $\pm 2.5V$ .

**Note 10:** The LT1113 is designed, characterized and expected to meet these extended temperature limits, but is not tested at  $-40^\circ C$  and  $85^\circ C$ . Guaranteed I grade parts are available. Consult factory.

**Note 11:**  $\Delta CMRR$  and  $\Delta PSRR$  are defined as follows:

- (1) CMRR and PSRR are measured in  $\mu V/V$  on the individual amplifiers.
- (2) The difference is calculated between the matching sides in  $\mu V/V$ .
- (3) The result is converted to dB.

**Note 12:** The LT1113 is measured in an automated tester in less than one second after application of power. Depending on the package used, power dissipation, heat sinking, and air flow conditions, the fully warmed-up chip temperature can be  $10^\circ C$  to  $50^\circ C$  higher than the ambient temperature.

## TYPICAL PERFORMANCE CHARACTERISTICS

0.1Hz to 10Hz Voltage Noise

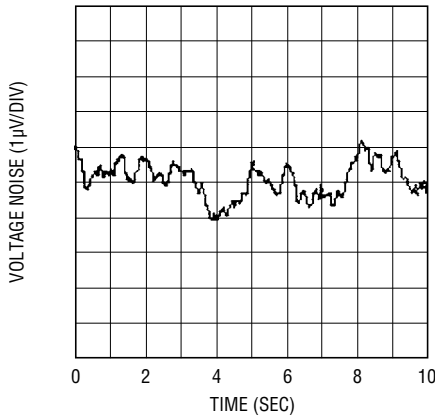

1113 G01

1kHz Output Voltage Noise Density vs Source Resistance

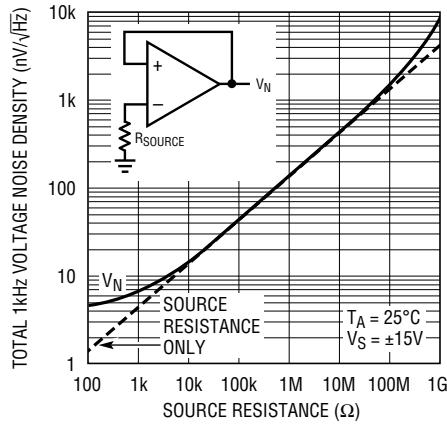

1113 G02

Voltage Noise vs Frequency

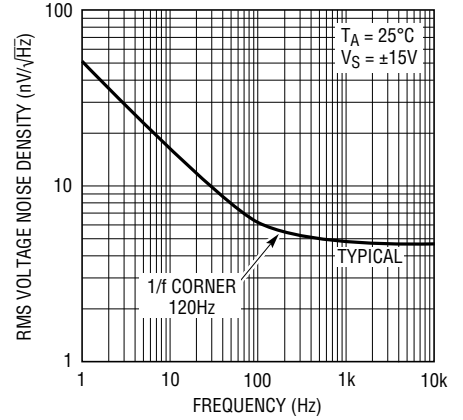

1113 G03

Voltage Noise vs Chip Temperature

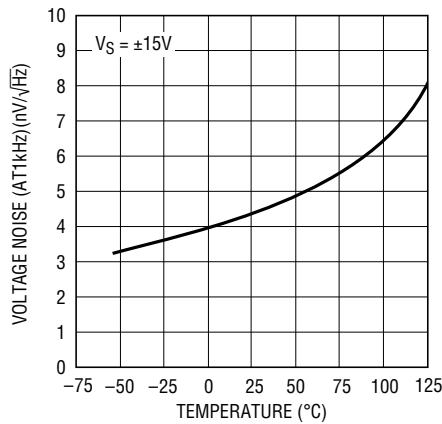

1113 G04

Input Bias and Offset Currents vs Chip Temperature

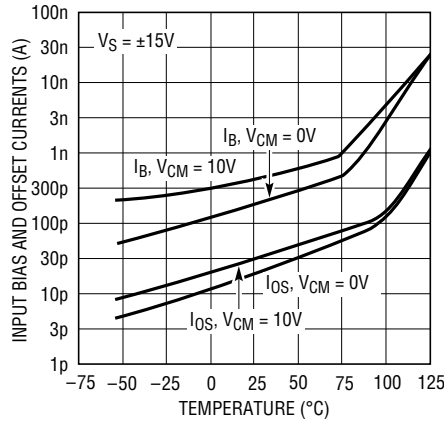

1113 G05

Input Bias and Offset Currents Over the Common Mode Range

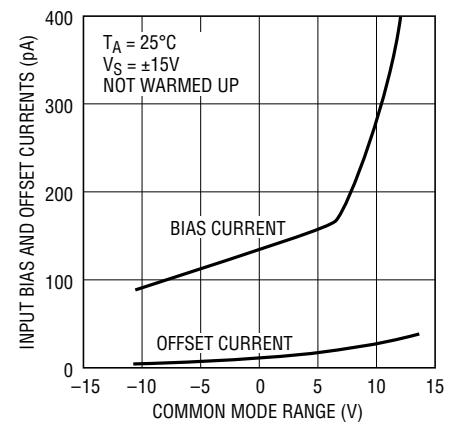

1113 G06

# TYPICAL PERFORMANCE CHARACTERISTICS

**Common Mode Limit vs Temperature**

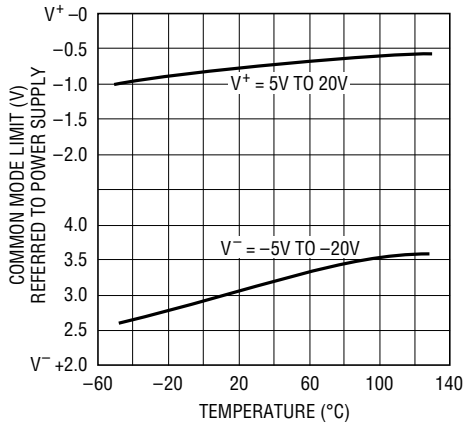

1113 G07

**Common Mode Rejection Ratio vs Frequency**

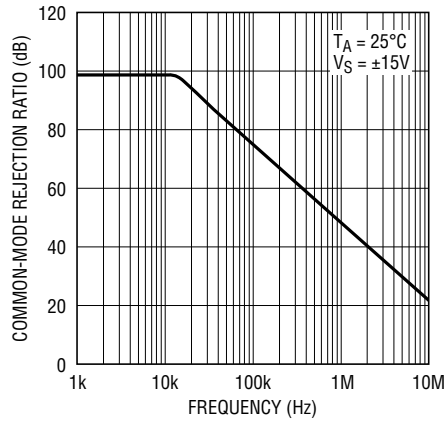

1113 G08

**Power Supply Rejection Ratio vs Frequency**

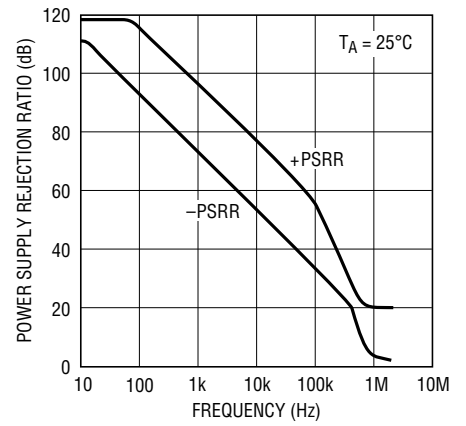

1113 G09

**Voltage Gain vs Frequency**

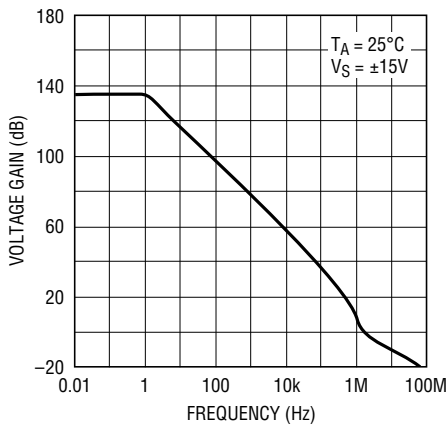

1113 G10

**Voltage Gain vs Chip Temperature**

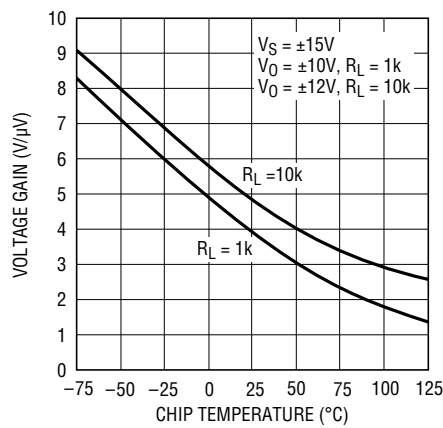

1113 G11

**Gain and Phase Shift vs Frequency**

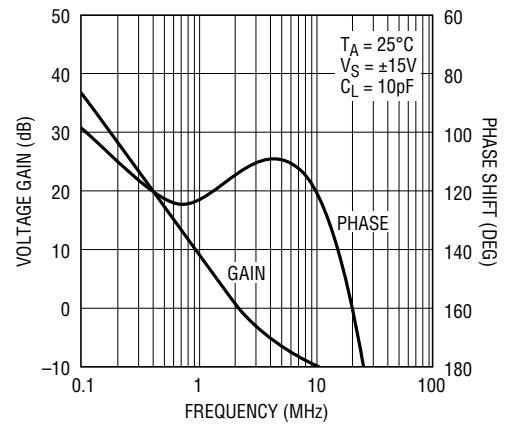

1113 G12

**Small-Signal Transient Response**

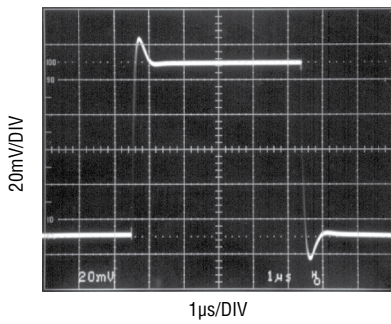

$A_V = 1$   
 $C_L = 10\text{pF}$   
 $V_S = \pm 15\text{V}, \pm 5\text{V}$

1113 G13

**Large-Signal Transient Response**

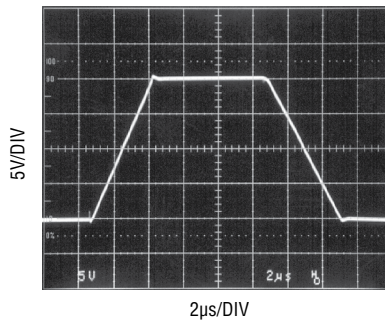

$A_V = 1$   
 $C_L = 10\text{pF}$   
 $V_S = \pm 15\text{V}$

1113 G14

**Supply Current vs Supply Voltage**

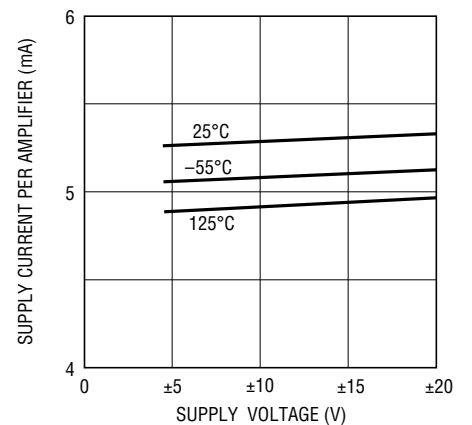

1113 G15

# TYPICAL PERFORMANCE CHARACTERISTICS

**Output Voltage Swing vs Load Current**

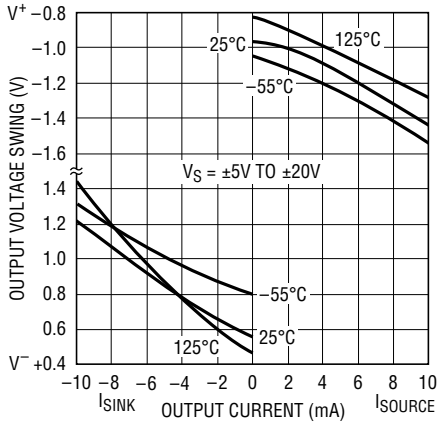

1113 G16

**Capacitive Load Handling**

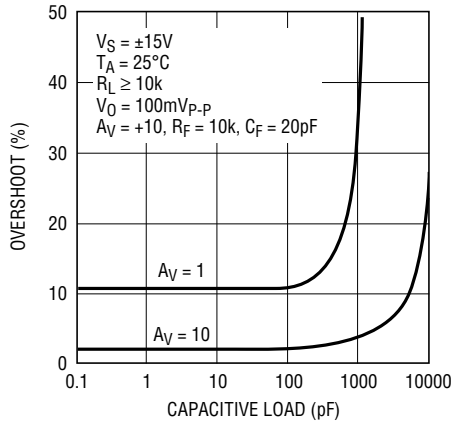

1113 G17

**Slew Rate and Gain Bandwidth Product vs Temperature**

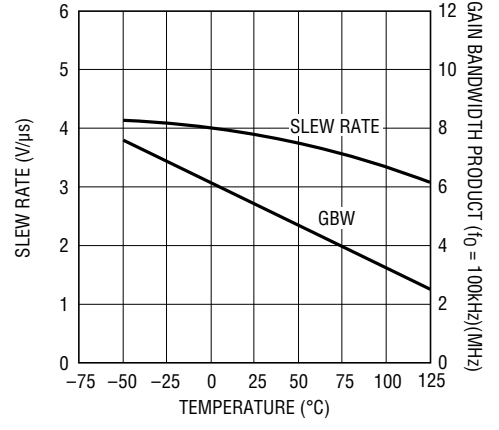

1113 G18

**Distribution of Offset Voltage Drift with Temperature (J8)**

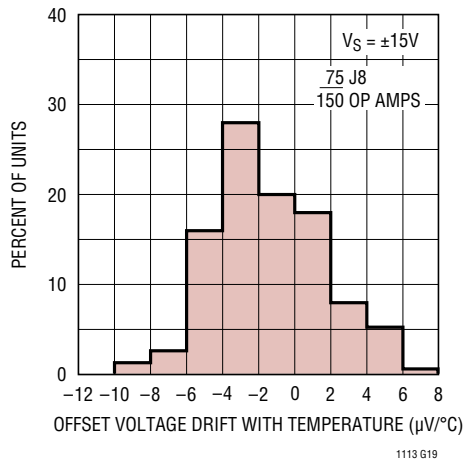

1113 G19

**Distribution of Offset Voltage Drift with Temperature (N8, S8)**

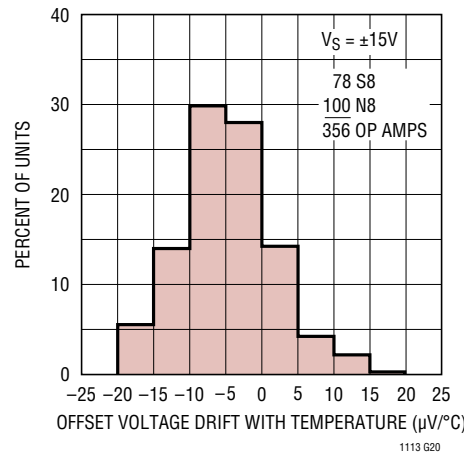

1113 G20

**Warm-Up Drift**

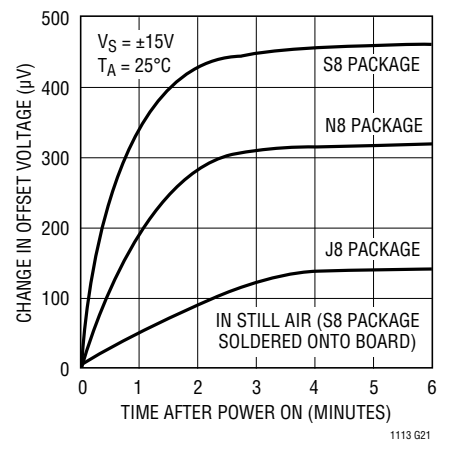

1113 G21

**THD and Noise vs Frequency for Noninverting Gain**

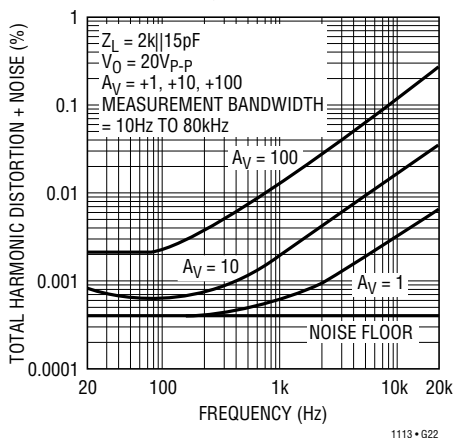

1113 G22

**THD and Noise vs Frequency for Inverting Gain**

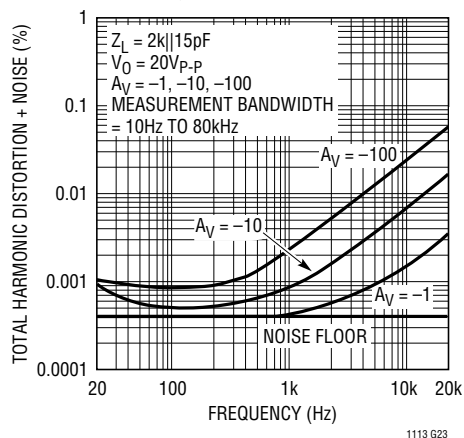

1113 G23

**Channel Separation vs Frequency**

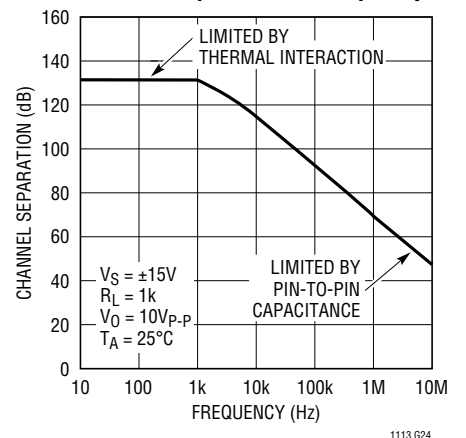

1113 G24

\*See LT1115 data sheet for definition of CCIF testing.

# TYPICAL PERFORMANCE CHARACTERISTICS

**THD and Noise vs Output Amplitude for Noninverting Gain**

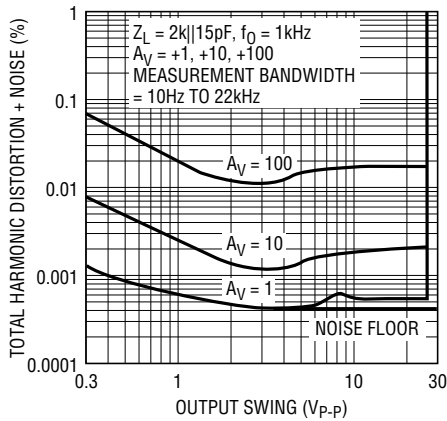

1113 • G25

**THD and Noise vs Output Amplitude for Inverting Gain**

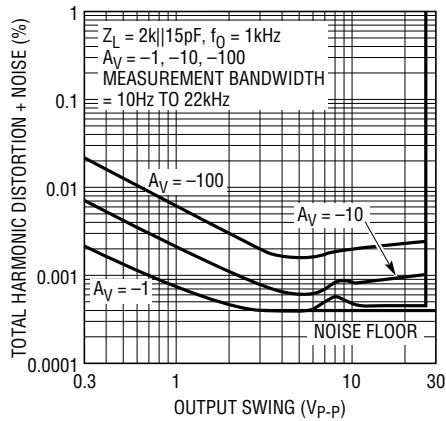

1113 • G26

**CCIF IMD Test (Equal Amplitude Tones at 13kHz, 14kHz)\***

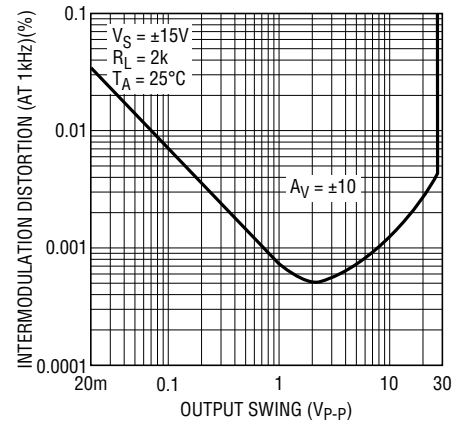

1113 • G27

# APPLICATIONS INFORMATION

The LT1113 dual in the plastic and ceramic DIP packages are pin compatible with and directly replace such JFET op amps as the OPA2111 and OPA2604 with improved noise performance. Being the lowest noise dual JFET op amp available to date, the LT1113 can replace many bipolar op amps that are used in amplifying low level signals from high impedance transducers. The best bipolar op amps will eventually loose out to the LT1113 when transducer

impedance increases due to higher current noise. The low voltage noise of the LT1113 allows it to surpass every dual and most single JFET op amps available. For the best performance versus area available anywhere, the LT1113 is offered in the narrow SO-8 surface mount package with standard pinout and no degradation in performance.

The low voltage and current noise offered by the LT1113 makes it useful in a wide range of applications, especially where high impedance, capacitive transducers are used such as hydrophones, precision accelerometers and photo diodes. The total output noise in such a system is the gain times the RMS sum of the op amp input referred voltage noise, the thermal noise of the transducer, and the op amp bias current noise times the transducer impedance. Figure 1 shows total input voltage noise versus source resistance. In a low source resistance (<5k) application the op amp voltage noise will dominate the total noise. This means the LT1113 will beat out any dual JFET op amp, only the lowest noise bipolar op amps have the edge (at low source resistances). As the source resistance increases from 5k to 50k, the LT1113 will match the best bipolar op amps for noise performance, since the thermal noise of the transducer (4kTR) begins to dominate the total noise. A further increase in source resistance, above 50k, is where the op amp's current noise component

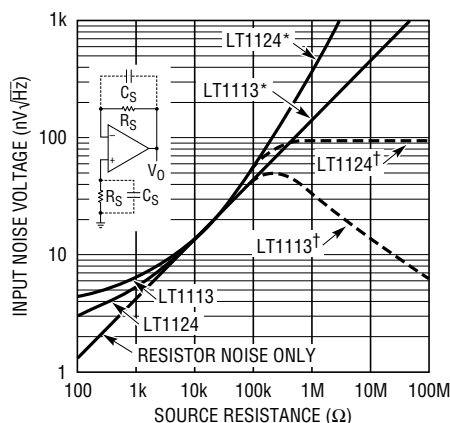

SOURCE RESISTANCE =  $2R_S = R$   
 \* PLUS RESISTOR  
 † PLUS RESISTOR || 1000pF CAPACITOR  
 $V_n = A_V \sqrt{V_n^2(OP\ AMP) + 4KTR + 2q I_B \cdot R^2}$

**Figure 1. Comparison of LT1113 and LT1124 Total Output 1kHz Voltage Noise Versus Source Resistance**

APPLICATIONS INFORMATION

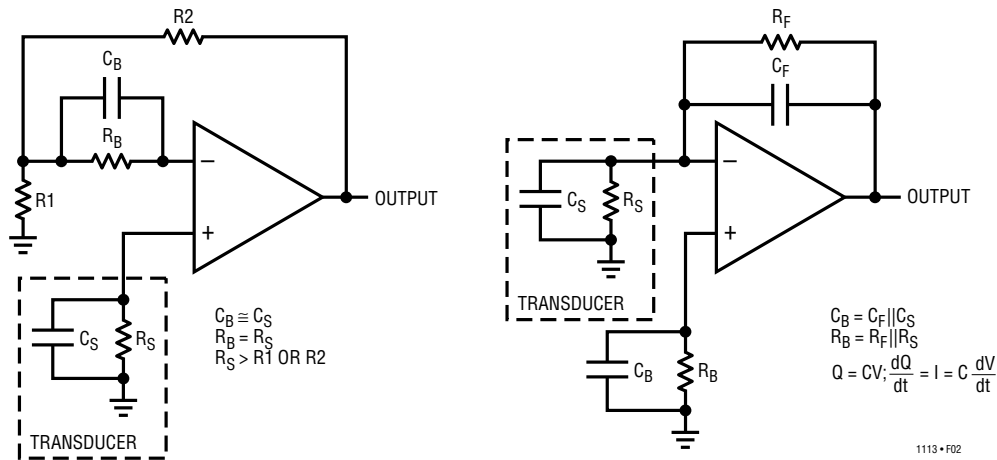

Figure 2. Noninverting and Inverting Gain Configurations

( $2qI_B R_{TRANS}$ ) will eventually dominate the total noise. At these high source resistances, the LT1113 will outperform the lowest noise bipolar op amp due to the inherently low current noise of FET input op amps. Clearly, the LT1113 will extend the range of high impedance transducers that can be used for high signal to noise ratios. This makes the LT1113 the best choice for high impedance, capacitive transducers.

The high input impedance JFET front end makes the LT1113 suitable in applications where very high charge sensitivity is required. Figure 2 illustrates the LT1113 in its inverting and noninverting modes of operation. A charge amplifier is shown in the inverting mode example; here the gain depends on the principle of charge conservation at the input of the LT1113. The charge across the transducer capacitance,  $C_S$ , is transferred to the feedback capacitor  $C_F$ , resulting in a change in voltage,  $dV$ , equal to  $dQ/C_F$ . The gain therefore is  $1 + C_F/C_S$ . For unity gain,  $C_F$  should equal the transducer capacitance plus the input capacitance of the LT1113 and  $R_F$  should equal  $R_S$ . In the noninverting mode example, the transducer current is converted to a change in voltage by the transducer capacitance; this voltage is then buffered by the LT1113 with a gain of  $1 + R_1/R_2$ . A DC path is provided by  $R_S$ , which is either the transducer impedance or an external resistor. Since  $R_S$  is usually several orders of magnitude greater than the

parallel combination of  $R_1$  and  $R_2$ ,  $R_B$  is added to balance the DC offset caused by the noninverting input bias current and  $R_S$ . The input bias currents, although small at room temperature, can create significant errors over increasing temperature, especially with transducer resistances of up to 100M or more. The optimum value for  $R_B$  is determined by equating the thermal noise ( $4kTR_S$ ) to the current noise ( $2qI_B$ ) times  $R_S^2$ . Solving for  $R_S$  results in  $R_B = R_S = 2V_T/I_B$

$$\left( V_T = \frac{kT}{q} = 26\text{mV at } 25^\circ\text{C} \right)$$

A parallel capacitor,  $C_B$ , is used to cancel the phase shift caused by the op amp input capacitance and  $R_B$ .

**Reduced Power Supply Operation**

The LT1113 can be operated from  $\pm 5V$  supplies for lower power dissipation resulting in lower  $I_B$  and noise at the expense of reduced dynamic range. To illustrate this benefit, let's look at the following example:

An LT1113CS8 operates at an ambient temperature of  $25^\circ\text{C}$  with  $\pm 15V$  supplies, dissipating 318mW of power (typical supply current = 10.6mA for the dual). The SO-8 package has a  $\theta_{JA}$  of  $190^\circ\text{C/W}$ , which results in a die temperature increase of  $60.4^\circ\text{C}$  or a room temperature die operating temperature of  $85.4^\circ\text{C}$ . At  $\pm 5V$  supplies, the die tempera-

## APPLICATIONS INFORMATION

INPUT:  $\pm 5.2V$  Sine Wave

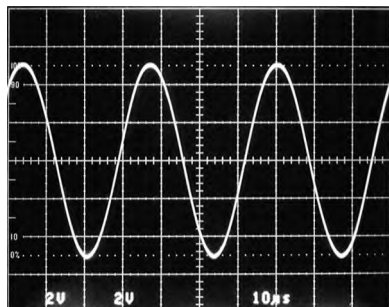

LT1113 Output

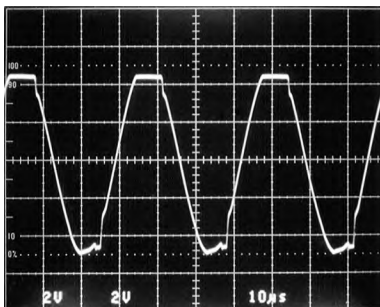

OPA2111 Output

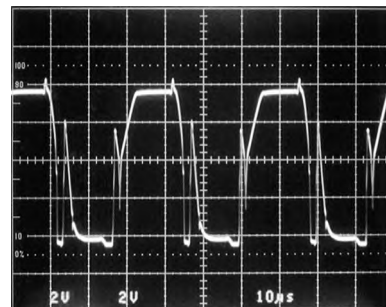

Figure 3. Voltage Follower with Input Exceeding the Common Mode Range ( $V_S = \pm 5V$ )

ture increases by only one third of the previous amount or  $20.1^{\circ}\text{C}$  resulting in a typical die operating temperature of only  $45.1^{\circ}\text{C}$ . A 40 degree reduction of die temperature is achieved at the expense of a 20V reduction in dynamic range. If no DC correction resistor is used at the input, the input referred offset will be the input bias current at the operating die temperature times the transducer resistance (refer to Input Bias and Offset Currents vs Chip Temperature graph in Typical Performance Characteristics section). A 100mV input  $V_{OS}$  is the result of a 1nA  $I_B$  (at  $85^{\circ}\text{C}$ ) dropped across a 100M transducer resistance; at  $\pm 5V$  supplies, the input offset is only 28mV ( $I_B$  at  $45^{\circ}\text{C}$  is 280pA). Careful selection of a DC correction resistor ( $R_B$ ) will reduce the IR errors due to  $I_B$  by an order of magnitude. A further reduction of IR errors can be achieved by using a DC servo circuit shown in the applications section of this data sheet. The DC servo has the advantage of reducing a wide range of IR errors to the millivolt level over a wide temperature variation. The preservation of dynamic range is especially important when reduced supplies are used, since input bias currents can exceed the nanoamp level for die temperatures over  $85^{\circ}\text{C}$ .

To take full advantage of a wide input common mode range, the LT1113 was designed to eliminate phase reversal. Referring to the photographs shown in Figure 3, the LT1113 is shown operating in the follower mode ( $A_V = +1$ ) at  $\pm 5V$  supplies with the input swinging  $\pm 5.2V$ . The output of the

LT1113 clips cleanly and recovers with no phase reversal, unlike the competition as shown by the last photograph. This has the benefit of preventing lock-up in servo systems and minimizing distortion components. The effect of input and output overdrive on one amplifier has no effect on the other, as each amplifier is biased independently.

### Advantages of Matched Dual Op Amps

In many applications the performance of a system depends on the matching between two operational amplifiers rather than the individual characteristics of the two op amps. Two or three op amp instrumentation amplifiers, tracking voltage references and low drift active filters are some of the circuits requiring matching between two op amps.

The well-known triple op amp configuration in Figure 4 illustrates these concepts. Output offset is a function of the difference between the two halves of the LT1113. This error cancellation principle holds for a considerable number of input referred parameters in addition to offset voltage and bias current. Input bias current will be the average of the two noninverting input currents ( $I_{B+}$ ). The difference between these two currents ( $\Delta I_{B+}$ ) is the offset current of the instrumentation amplifier. Common mode and power supply rejections will be dependent only on the match between the two amplifiers (assuming perfect resistor matching).

APPLICATIONS INFORMATION

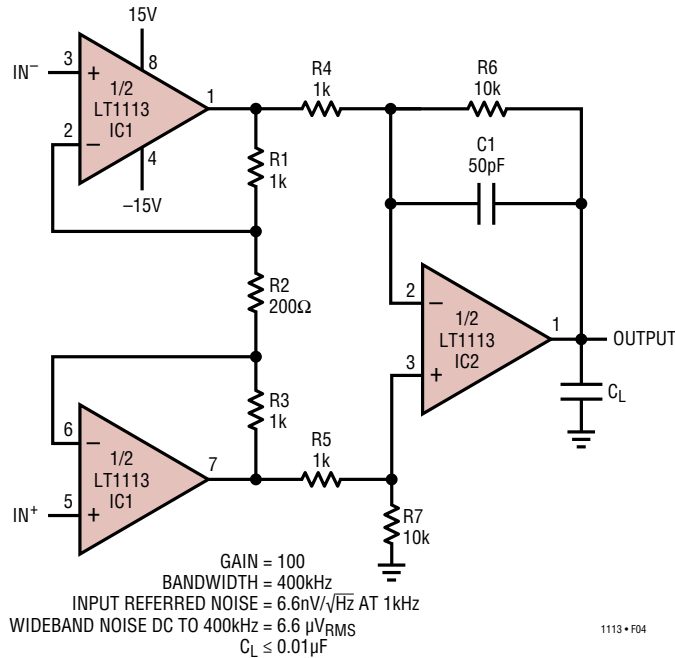

Figure 4. Three Op Amp Instrumentation Amplifier

The concepts of common mode and power supply rejection ratio match ( $\Delta\text{CMRR}$  and  $\Delta\text{PSRR}$ ) are best demonstrated with a numerical example:

Assume  $\text{CMRR}_A = +50\ \mu\text{V}/\text{V}$  or 86dB,

and  $\text{CMRR}_B = +39\ \mu\text{V}/\text{V}$  or 88dB,

then  $\Delta\text{CMRR} = 11\ \mu\text{V}/\text{V}$  or 99dB;

if  $\text{CMRR}_B = -39\ \mu\text{V}/\text{V}$  which is still 88dB,

then  $\Delta\text{CMRR} = 89\ \mu\text{V}/\text{V}$  or 81dB

Clearly the LT1113, by specifying and guaranteeing all of these matching parameters, can significantly improve the performance of matching-dependent circuits.

Typical performance of the instrumentation amplifier:

Input offset voltage = 0.8mV

Input bias current = 320pA

Input offset current = 10pA

Input resistance =  $10^{11}\ \Omega$

Input noise =  $3.4\ \mu\text{V}_{\text{P-P}}$

High Speed Operation

The low noise performance of the LT1113 was achieved by making the input JFET differential pair large to maximize the first stage gain. Increasing the JFET geometry also increases the parasitic gate capacitance, which if left unchecked, can result in increased overshoot and ringing. When the feedback around the op amp is resistive ( $R_F$ ), a pole will be created with  $R_F$ , the source resistance and capacitance ( $R_S, C_S$ ), and the amplifier input capacitance ( $C_{\text{IN}} = 27\text{pF}$ ). In closed loop gain configurations and with  $R_S$  and  $R_F$  in the kilohm range (Figure 5), this pole can create excess phase shift and even oscillation. A small capacitor ( $C_F$ ) in parallel with  $R_F$  eliminates this problem. With  $R_S(C_S + C_{\text{IN}}) = R_F C_F$ , the effect of the feedback pole is completely removed.

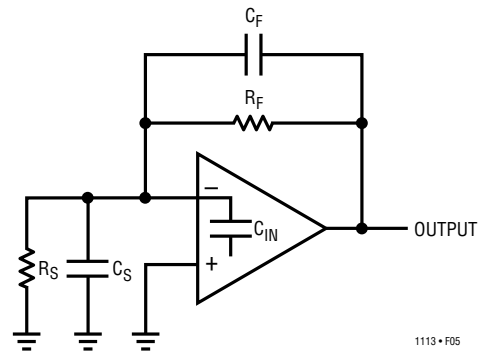
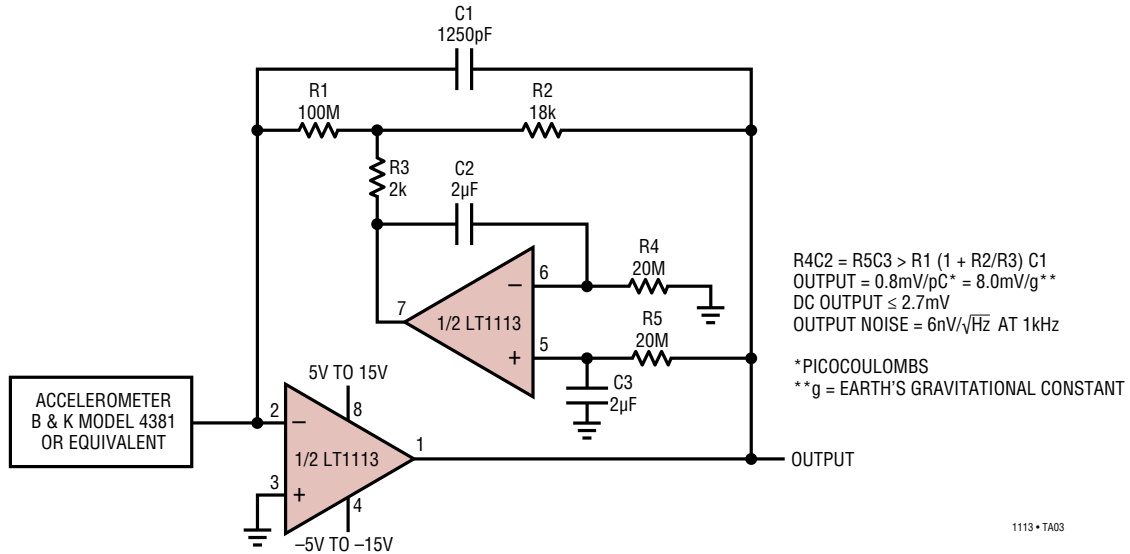

Figure 5.

# TYPICAL APPLICATIONS

## Accelerometer Amplifier with DC Servo



## Paralleling Amplifiers to Reduce Voltage Noise

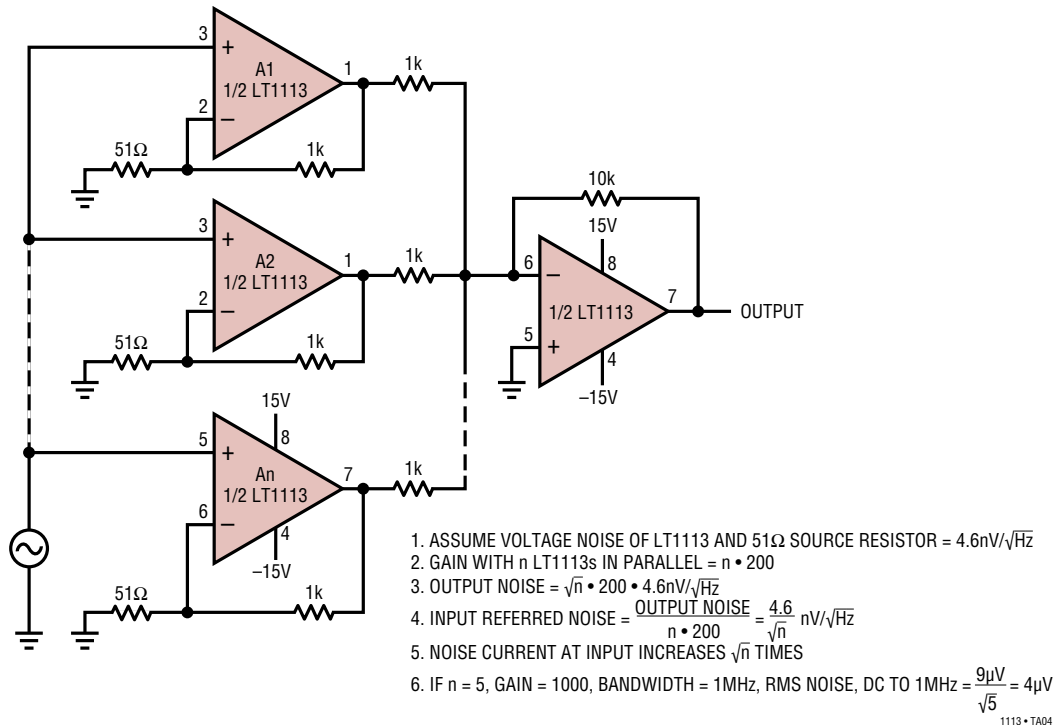

TYPICAL APPLICATIONS

Low Noise Light Sensor with DC Servo

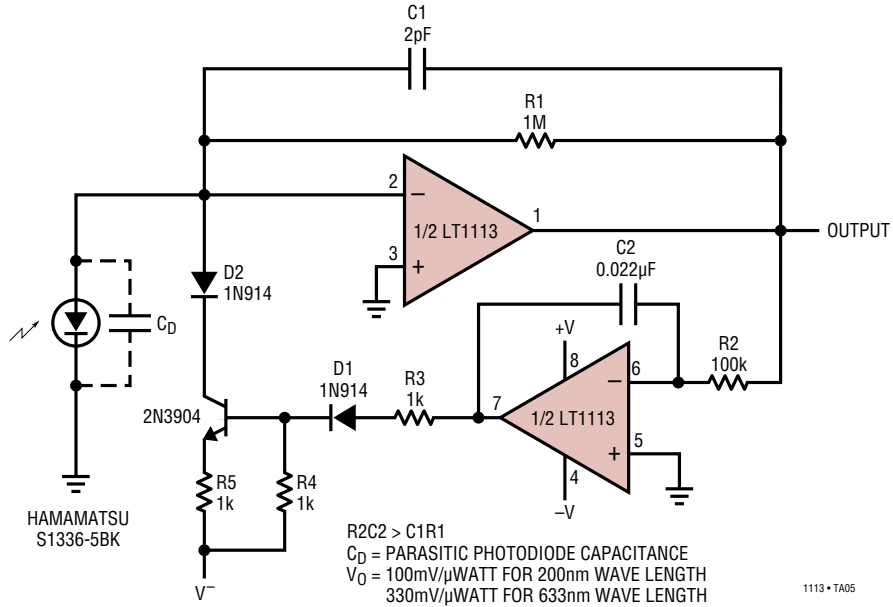

10Hz Fourth Order Chebyshev Lowpass Filter (0.01dB Ripple)

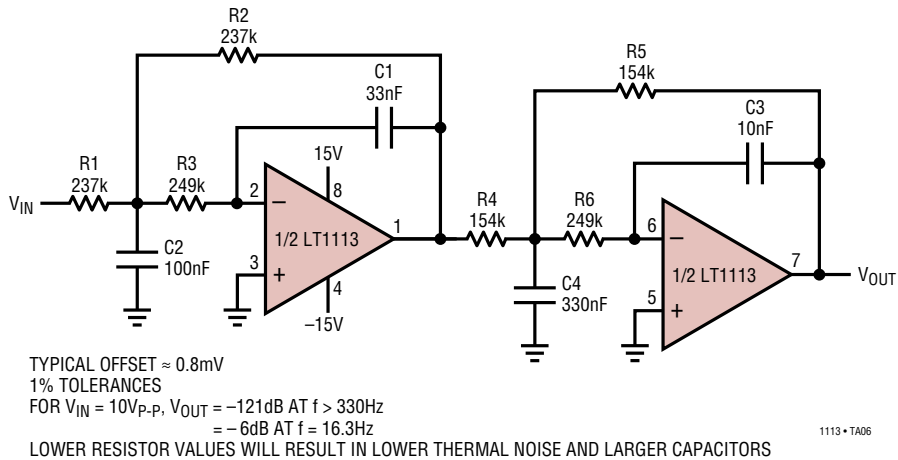

# PACKAGE DESCRIPTION

Please refer to <http://www.linear.com/designtools/packaging/> for the most recent package drawings.

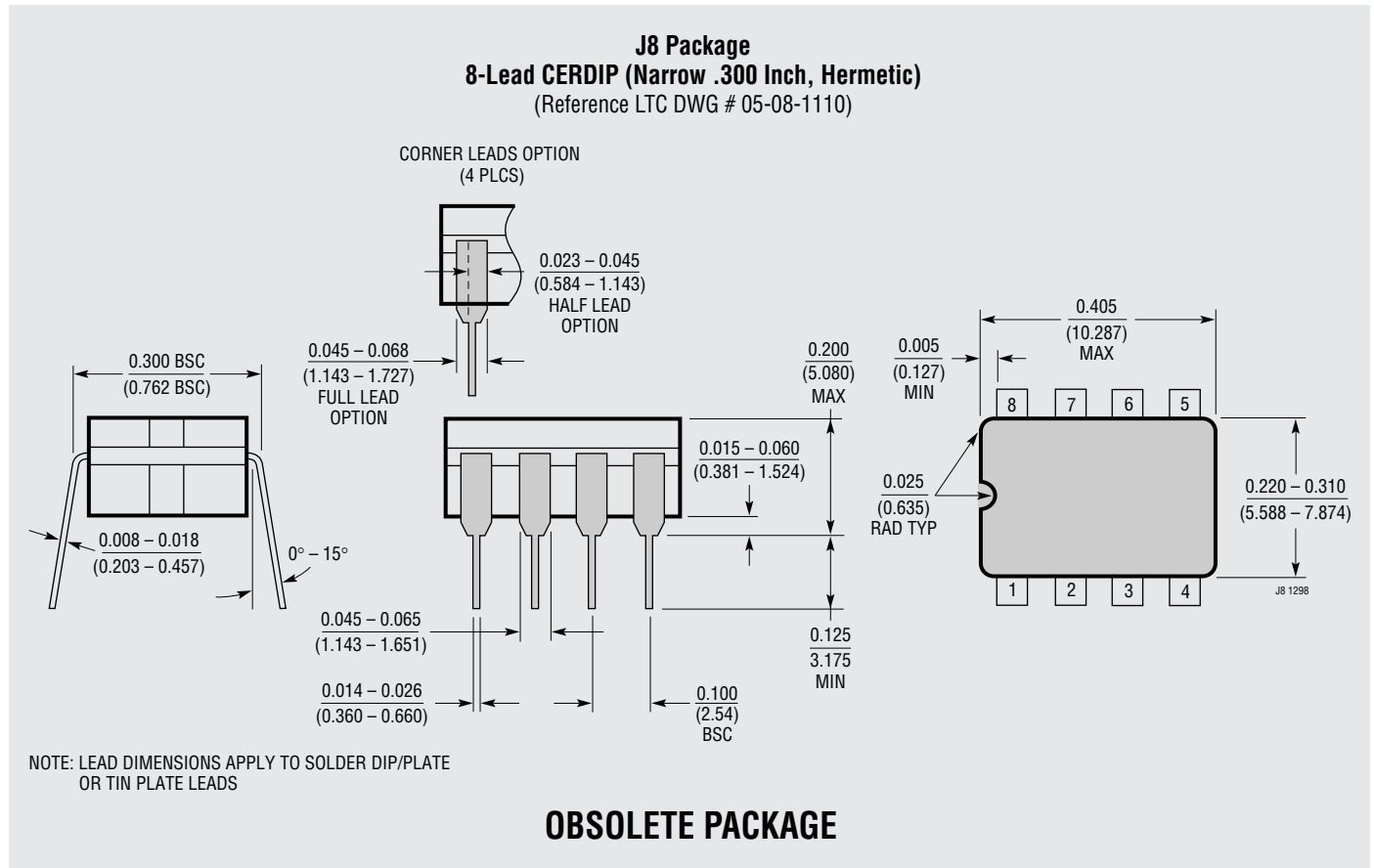

**N Package**  
**8-Lead PDIP (Narrow .300 Inch)**  
 (Reference LTC DWG # 05-08-1510 Rev I)

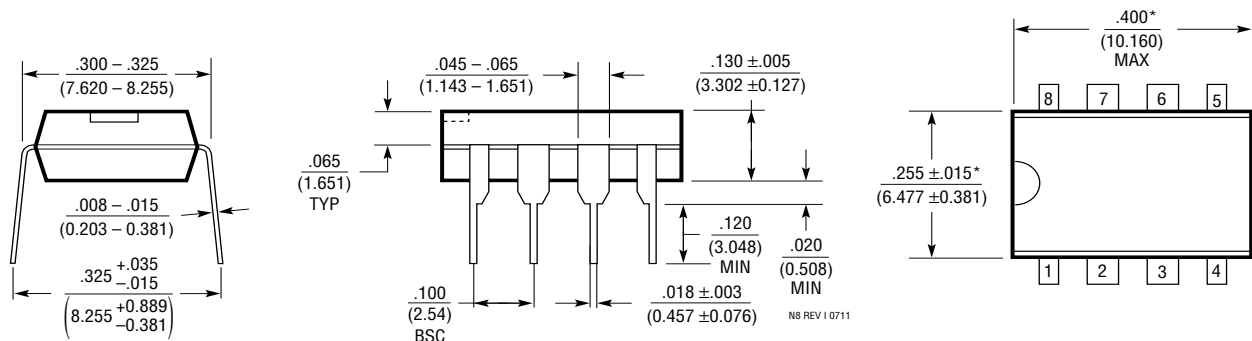

NOTE:  
 1. DIMENSIONS ARE  $\frac{\text{INCHES}}{\text{MILLIMETERS}}$   
 \*THESE DIMENSIONS DO NOT INCLUDE MOLD FLASH OR PROTRUSIONS.  
 MOLD FLASH OR PROTRUSIONS SHALL NOT EXCEED .010 INCH (0.254mm)

# PACKAGE DESCRIPTION

Please refer to <http://www.linear.com/designtools/packaging/> for the most recent package drawings.

## S8 Package 8-Lead Plastic Small Outline (Narrow .150 Inch)

(Reference LTC DWG # 05-08-1610 Rev G)

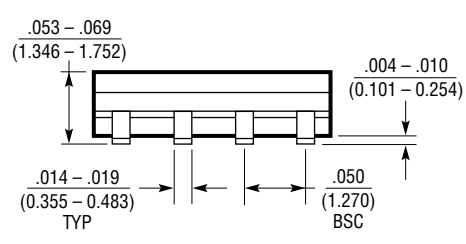
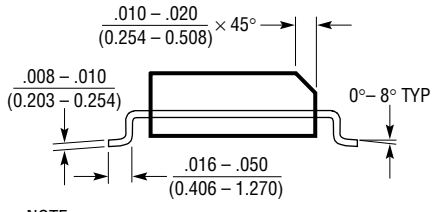
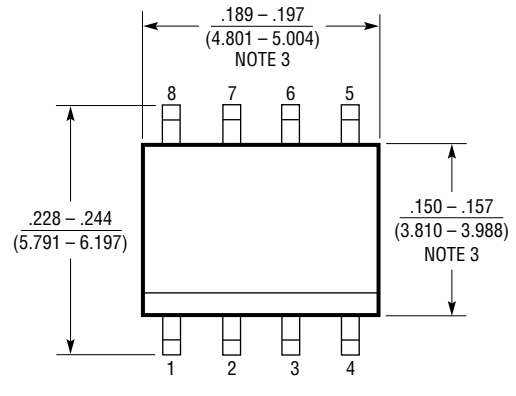
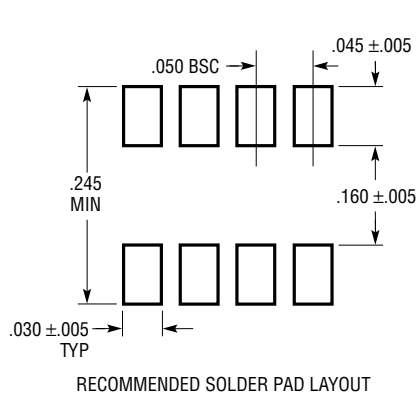

- NOTE:
1. DIMENSIONS IN INCHES (MILLIMETERS)
  2. DRAWING NOT TO SCALE
  3. THESE DIMENSIONS DO NOT INCLUDE MOLD FLASH OR PROTRUSIONS. MOLD FLASH OR PROTRUSIONS SHALL NOT EXCEED  $.006"$  ( $0.15\text{mm}$ )
  4. PIN 1 CAN BE BEVEL EDGE OR A DIMPLE

S08 REV G 0212

**REVISION HISTORY** (Revision history begins at Rev C)

REV	DATE	DESCRIPTION	PAGE NUMBER
C	09/15	Updated Order Information table format. Updated package drawings.	2 15, 16

## TYPICAL APPLICATION

### Light Balance Detection Circuit

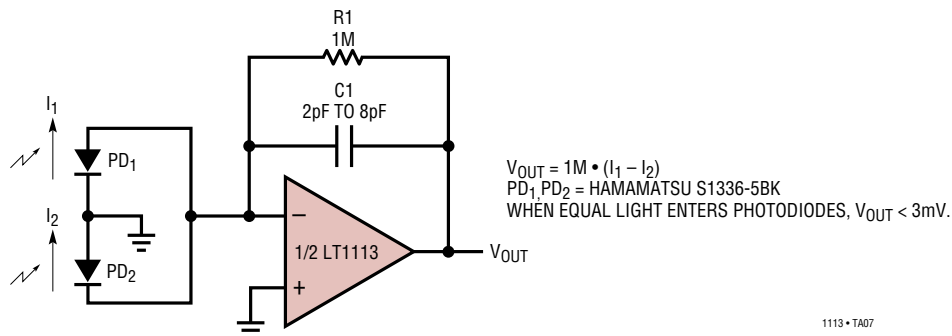

### Unity Gain Buffer with Extended Load Capacitance Drive Capability

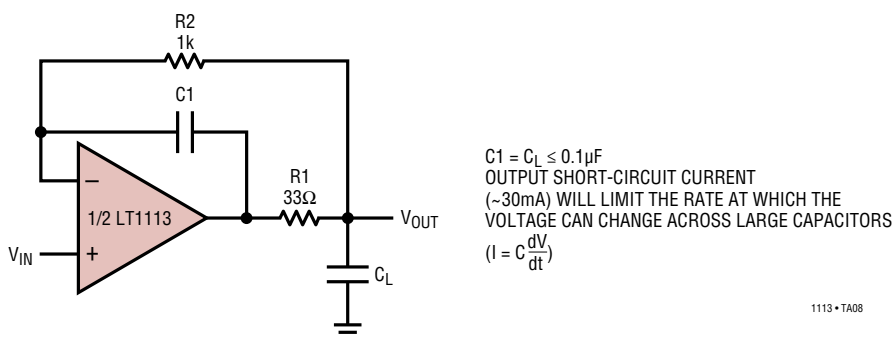

## RELATED PARTS

PART NUMBER	DESCRIPTION	COMMENTS
<a href="#">LT1028</a>	Single Low Noise Precision Op Amp	$V_{NOISE} = 1.1nV/\sqrt{Hz}$ Max
<a href="#">LT1124</a>	Dual Low Noise Precision Op Amp	$V_{NOISE} = 4.2nV/\sqrt{Hz}$ Max
<a href="#">LT1169</a>	Dual Low Noise Precision JFET Op Amp	10pA $I_B$
<a href="#">LT1462</a>	Dual Picoamp $I_B$ C-Load™ Op Amp	$I_B = 2pA$ Max, 10000pF C-Load, $I_S = 45\mu A$
<a href="#">LT1464</a>	Dual Picoamp $I_B$ C-Load Op Amp	$I_B = 2pA$ Max, 10000pF C-Load, $I_S = 200\mu A$
<a href="#">LT1792</a>	Single Low Noise Precision Op Amp	Single LT1113
<a href="#">LT1793</a>	Single Low Noise Precision Op Amp	Single LT1169

## Looking for pricing, stock, or lifecycle information?

Click below to explore more details on WIN SOURCE:

 [View LT1113CS8#PBF on WIN SOURCE](#)

 [Linear Technology](#) Information

## Optimize Your Supply Chain with WIN SOURCE Solutions

-  Global Sourcing Solution
-  Obsolete Management
-  Cost Control Management
-  Shortage Management
-  Alternative Solution
-  Excess Inventory Management