



**THE DATASHEET OF  
LT1080CSW#PBF**



## FEATURES

- **Superior to CMOS**
  - Improved Speed: Operates over 120kBaud
  - Improved Protection: Outputs Can Be Forced to  $\pm 30V$  without Damage
  - Three-State Outputs Are High Impedance When Off
  - Only Needs  $1\mu F$  Capacitors
- Absolutely No Latchup
- CMOS Comparable Low Power: 60mW
- Can Power Additional RS232 Drivers: 10mA
- Supply Current in Shutdown:  $1\mu A$
- Available in SO Package
- Available with or without Shutdown

## APPLICATIONS

- Portable Computers
- Battery-Powered RS232 Systems
- Power Supply Generator
- Terminals
- Modems

## DESCRIPTION

The LT<sup>®</sup>1080/LT1081 are the only dual RS232 driver/receiver with charge pump to guarantee absolutely no latchup. These interface optimized devices provide a realistic balance between CMOS levels of power dissipation and real world requirements for ruggedness. The driver outputs are fully protected against overload and can be shorted to  $\pm 30V$ . Unlike CMOS, the advanced architecture of the LT1080/LT1081 does not load the signal line when “shut down” or when power is off. Both the receiver and RS232 outputs are put into a high impedance state. An advanced output stage allows driving higher capacitive loads at higher speeds with exceptional ruggedness against ESD.

For applications requiring up to five drivers and five receivers with charge pump in one package see the LT1130A Series data sheet. A version of the LT1080/LT1081, the LT1180A and LT1181A that use only  $0.1\mu F$  capacitors, is also available. All of Linear Technology’s RS232 ICs are available in standard surface mount packages.

LT, LTC and LT are registered trademarks of Linear Technology Corporation.

## TYPICAL APPLICATION

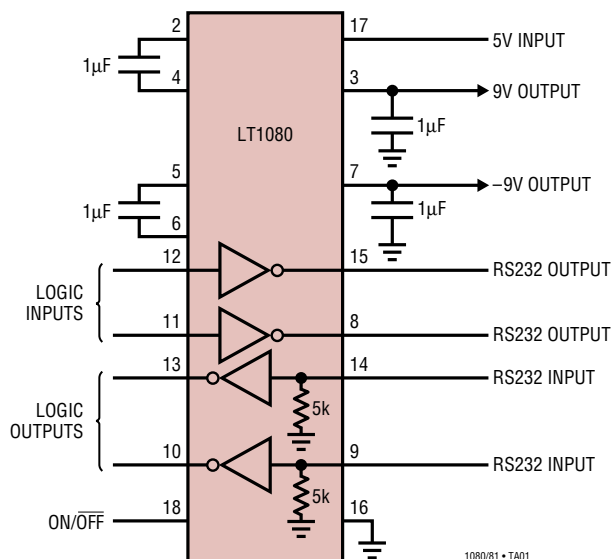

1080/81 • TA01

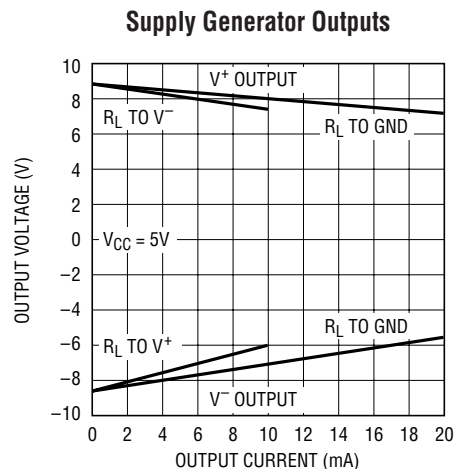

1080/81 TA01a

# LT1080/LT1081

## ABSOLUTE MAXIMUM RATINGS (Note 1)

Supply Voltage ( $V_{CC}$ ) .....	6V	Short-Circuit Duration	
$V^+$ .....	12V	$V^+$ .....	30 sec
$V^-$ .....	-12V	$V^-$ .....	30 sec
Input Voltage		Driver Output .....	Indefinite
Driver .....	$V^-$ to $V^+$	Receiver Output .....	Indefinite
Receiver .....	-30V to 30V	Operating Temperature Range	
ON/OFF Pin .....	GND to 12V	LT1080C/LT1081C .....	0°C to 70°C
Output Voltage		LT1080I/LT1081I .....	-40°C to 85°C
Driver .....	( $V^- + 30V$ ) to ( $V^+ - 30V$ )	<b>LT1080M/LT1081M (OBSOLETE) ...</b>	<b>-55°C to 125°C</b>
Receiver .....	-0.3V to ( $V_{CC} + 0.3V$ )	Storage Temperature Range .....	-65°C to 150°C
		Lead Temperature (Soldering, 10 sec) .....	300°C

## PACKAGE/ORDER INFORMATION

TOP VIEW	ORDER PART NUMBER	TOP VIEW	ORDER PART NUMBER
<p>NC 1 18 ON/OFF C1+ 2 17 V<sub>CC</sub> V+ 3 16 GND C1- 4 15 TR1 OUT C2+ 5 14 REC1 IN C2- 6 13 REC1 OUT V- 7 12 TR1 IN TR2 OUT 8 11 TR2 IN REC2 IN 9 10 REC2 OUT</p> <p>N PACKAGE 18-LEAD PDIP SW PACKAGE 18-LEAD PLASTIC SO WIDE T<sub>JMAX</sub> = 150°C, θ<sub>JA</sub> = 120°C/W, θ<sub>JC</sub> = 50°C/W (N) T<sub>JMAX</sub> = 150°C, θ<sub>JA</sub> = 90°C/W, θ<sub>JC</sub> = 26°C/W (SW)</p>	LT1080CN LT1080CSW LT1080IN LT1080ISW	<p>C1+ 1 16 V<sub>CC</sub> V+ 2 15 GND C1- 3 14 TR1 OUT C2+ 4 13 REC1 IN C2- 5 12 REC1 OUT V- 6 11 TR1 IN TR2 OUT 7 10 TR2 IN REC2 IN 8 9 REC2 OUT</p> <p>N PACKAGE 16-LEAD PDIP SW PACKAGE 16-LEAD PLASTIC SO WIDE T<sub>JMAX</sub> = 150°C, θ<sub>JA</sub> = 120°C/W, θ<sub>JC</sub> = 50°C/W (N) T<sub>JMAX</sub> = 150°C, θ<sub>JA</sub> = 95°C/W, θ<sub>JC</sub> = 27°C/W (SW)</p>	LT1081CN LT1081CSW LT1081IN LT1081ISW
<p>J PACKAGE 18-LEAD CERDIP T<sub>JMAX</sub> = 150°C, θ<sub>JA</sub> = 100°C/W, θ<sub>JC</sub> = 40°C/W (J)</p> <p><b>OBSOLETE PACKAGE</b> Consider N Package for Alternate Source</p>	LT1080CJ LT1080MJ	<p>J PACKAGE 16-LEAD CERDIP T<sub>JMAX</sub> = 150°C, θ<sub>JA</sub> = 100°C/W, θ<sub>JC</sub> = 40°C/W (J)</p> <p><b>OBSOLETE PACKAGE</b> Consider N Package for Alternate Source</p>	LT1081CJ LT1081MJ

Consult LTC Marketing for parts specified with wider operating temperature ranges.

**ELECTRICAL CHARACTERISTICS** The ● denotes the specifications which apply over the full operating temperature range, otherwise specifications are at  $T_A = 25^\circ\text{C}$ . (Note 2)

PARAMETER	CONDITIONS		MIN	TYP	MAX	UNITS	
<b>Driver</b>							
Output Voltage Swing	Load = 3k to GND Both Outputs	Positive	● 5	7.3		V	
		Negative	● -5	-6.5		V	
Logic Input Voltage Level	Input Low Level ( $V_{OUT} = \text{High}$ )		●	1.4	0.8	V	
	Input High Level ( $V_{OUT} = \text{Low}$ )		● 2	1.4		V	
Logic Input Current	$V_{IN} \geq 2\text{V}$		●	5	20	$\mu\text{A}$	
	$V_{IN} \leq 0.8\text{V}$		●	5	20	$\mu\text{A}$	
Output Short-Circuit Current	Sourcing Current, $V_{OUT} = 0\text{V}$			9	12	mA	
	Sinking Current, $V_{OUT} = 0\text{V}$			-9	-12	mA	
Output Leakage Current	SHUTDOWN (Note 3), $V_{OUT} = \pm 30\text{V}$		●	10	100	$\mu\text{A}$	
Data Rate (Note 6)	$R_L = 3\text{k}, C_L = 2500\text{pF}$			120		kBd	
	$R_L = 3\text{k}, C_L = 1000\text{pF}$			250		kBd	
Slew Rate	$R_L = 3\text{k}, C_L = 51\text{pF}$			4	15	$\text{V}/\mu\text{s}$	
<b>Receiver</b>							
Input Voltage Thresholds	Input Low Threshold	Commercial	●	0.8	1.3	V	
		Industrial and Military	●	0.2	1.3	V	
	Input High Threshold	Commercial	●		1.7	2.4	V
		Industrial and Military	●		1.7	3.0	V
Hysteresis		●	0.1	0.4	1	V	
Input Resistance	$V_{IN} = \pm 10\text{V}$			3	5	7	$\text{k}\Omega$
Output Voltage	Output Low, $I_{OUT} = -1.6\text{mA}$		●		0.2	0.4	V
	Output High, $I_{OUT} = 160\mu\text{A}$ ( $V_{CC} = 5\text{V}$ )		●	3.5	4.8		V
Output Short-Circuit Current	Sinking Current, $V_{OUT} = V_{CC}$			-10	-20	mA	
	Sourcing Current, $V_{OUT} = 0\text{V}$			0.6	1	mA	
Output Leakage Current	SHUTDOWN (Note 3), $0\text{V} \leq V_{OUT} \leq V_{CC}$		●		1	10	$\mu\text{A}$
<b>Power Supply Generator (Note 4)</b>							
$V^+$ Output Voltage	$I_{OUT} = 0\text{mA}$			8.0	9.0	V	
	$I_{OUT} = 10\text{mA}$			7.0	8.0	V	
	$I_{OUT} = 15\text{mA}$			6.5	7.5	V	
$V^-$ Output Voltage	$I_{OUT} = 0\text{mA}$			-7.5	-8.5	V	
	$I_{OUT} = -10\text{mA}$			-5.5	-6.5	V	
	$I_{OUT} = -15\text{mA}$			-5.0	-6.0	V	
Supply Current		●		12	22	mA	
Supply Leakage Current ( $V_{CC}$ )	SHUTDOWN (Note 3), LT1080 Only		●		1	100	$\mu\text{A}$
ON/OFF Pin Current	$0\text{V} \leq V_{ON/OFF} \leq 5\text{V}$ , LT1080 Only		●	-15		80	$\mu\text{A}$
Supply Rise Time	(Note 5), LT1080 Only				1		ms

**Note 1:** Absolute Maximum Ratings are those values beyond which the life of a device may be impaired.

**Note 2:** These parameters apply for  $4.5\text{V} \leq V_{CC} \leq 5.5\text{V}$  and  $V_{ON/OFF} = 3\text{V}$ , unless otherwise specified.

**Note 3:**  $V_{ON/OFF} = 0.4\text{V}$  for  $-55^\circ\text{C} \leq T_A \leq 50^\circ\text{C}$ , and  $V_{ON/OFF} = 0.2\text{V}$  for  $50^\circ\text{C} \leq T_A \leq 125^\circ\text{C}$ . (LT1080 only)

**Note 4:** Unless otherwise specified,  $V_{CC} = 5\text{V}$ , external loading of  $V^+$  and  $V^-$  equals zero and the driver outputs are low (inputs high).

**Note 5:** Time from either SHUTDOWN high or power on until  $V^+ \geq 6\text{V}$  and  $V^- \leq -6\text{V}$ . All external capacitors are  $1\mu\text{F}$ .

**Note 6:** Data rate operation guaranteed by slew rate, short-circuit current and propagation delay tests.

## PIN FUNCTIONS (Pin numbers refer to LT1080)

**C1<sup>+</sup>; C1<sup>-</sup>; C2<sup>+</sup>; C2<sup>-</sup> (Pins 2, 4, 5, 6):** Requires an external capacitor ( $\geq 1\mu\text{F}$ ) from C1<sup>+</sup> to C1<sup>-</sup> and another from C2<sup>+</sup> to C2<sup>-</sup>. Pin 2 can be used for connecting a second positive supply. When a separate positive supply is used, C1 can be deleted.

**V<sup>+</sup> (Pin 3):** Positive Supply for RS232 Drivers.  
 $V^+ \approx 2V_{CC} - 1.5\text{V}$ . Requires an external capacitor ( $\geq 1\mu\text{F}$ ) for charge storage. May be loaded (up to 15mA) for external system use. Loading does reduce V<sup>+</sup> voltage (see graphs). Capacitor may be tied to ground or +5V input supply. With multiple transceivers, the V<sup>+</sup> and V<sup>-</sup> pins may be paralleled into common capacitors.

**V<sup>-</sup> (Pin 7):** Negative Supply for RS232 Drivers.  
 $V^- \approx -(2V_{CC} - 2.5\text{V})$ . Requires an external capacitor ( $\geq 1\mu\text{F}$ ) for charge storage. May be loaded (up to -15mA) for external system use. Loading does reduce V<sup>-</sup> voltage (see graphs). With multiple transceivers, the V<sup>+</sup> and V<sup>-</sup> pins may be paralleled into common capacitors.

**TR2 OUT; TR1 OUT (Pins 8, 15):** Driver Outputs with RS232 Voltage Levels. Outputs are in a high impedance state when in the SHUTDOWN mode or when power is off ( $V_{CC} = 0\text{V}$ ) to allow data line sharing. Outputs are fully short-circuit protected from ( $V^- + 30\text{V}$ ) to ( $V^+ - 30\text{V}$ ) with power on, off or in the SHUTDOWN mode. Typical output breakdowns are greater than  $\pm 45\text{V}$  and higher applied

voltages will not damage the device if moderately current limited. Shorting one output will affect output from the other.

**REC2 IN; REC1 IN (Pins 9, 14):** Receiver Inputs. Accepts RS232 voltage levels ( $\pm 30\text{V}$ ) and has 0.4V of hysteresis to provide noise immunity. Input impedance is nominally  $5\text{k}\Omega$ .

**REC2 OUT; REC1 OUT (Pins 10, 13):** Receiver Outputs with TTL/CMOS Voltage Levels. Outputs are in a high impedance state when in the SHUTDOWN mode to allow data line sharing. Outputs are fully short-circuit protected to ground or  $V_{CC}$  with power on, off or in the SHUTDOWN mode.

**TR2 IN; TR1 IN (Pins 11, 12):** RS232 Driver Input Pins. Inputs are TTL/CMOS compatible. Inputs should not be allowed to float. Tie unused inputs to  $V_{CC}$ .

**GND (Pin 16):** Ground Pin.

**V<sub>CC</sub> (Pin 17):** Input Supply Pin. Supply current drops to zero in the SHUTDOWN mode.

**ON/OFF (Pin 18):** Controls the operation mode of the LT1080 and is TTL/CMOS compatible. A logic low puts the device in the SHUTDOWN mode which reduces input supply current to zero and places both driver and receiver outputs in a high impedance state. A logic high fully enables the device.

## TYPICAL PERFORMANCE CHARACTERISTICS

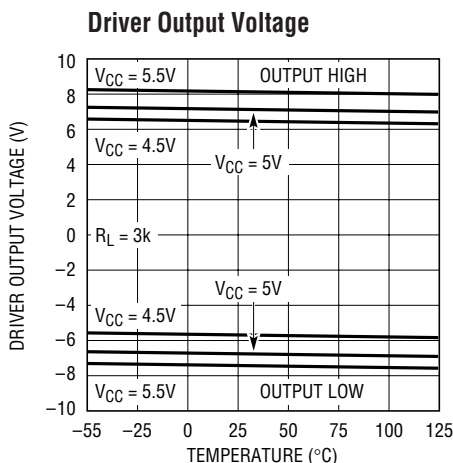

1080/81 G01

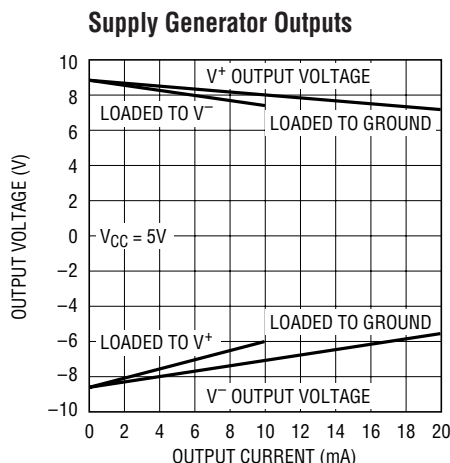

1080/81 G02

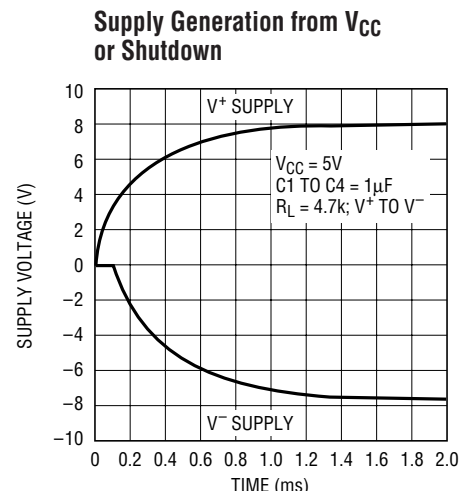

1080/81 G03  
10801fe

# TYPICAL PERFORMANCE CHARACTERISTICS

Receiver Input Thresholds

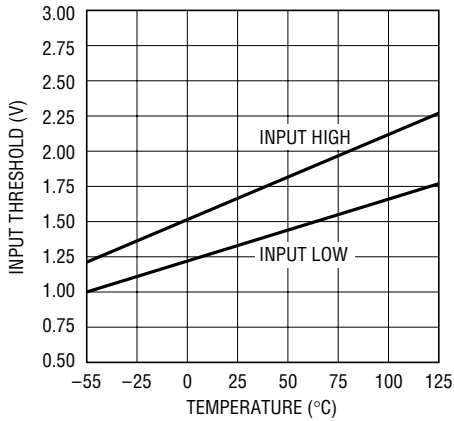

1080/81 G04

Receiver Output Short-Circuit Current

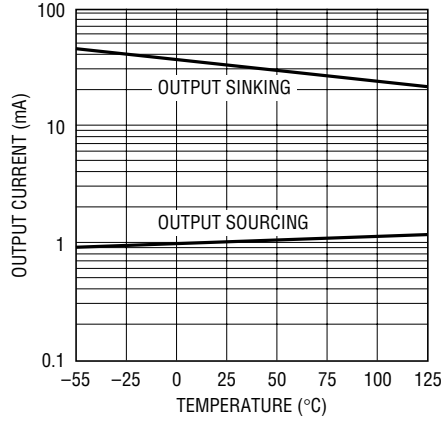

1080/81 G05

ON/OFF Pin Current vs Voltage

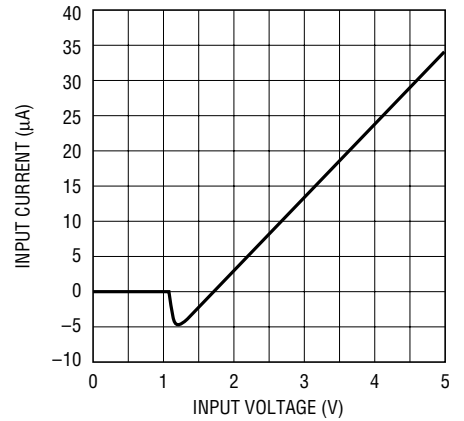

1080/81 G06

ON/OFF Pin Thresholds

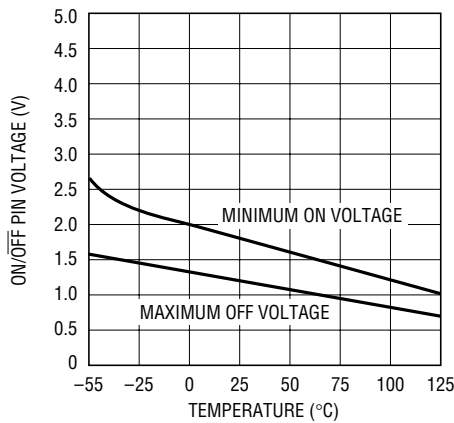

1080/81 G07

Supply Current in Shutdown

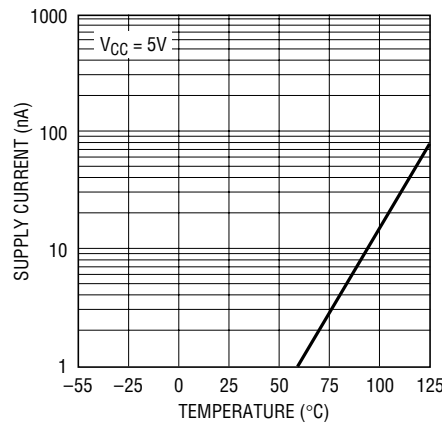

1080/81 G08

Driver Output Leakage in Shutdown

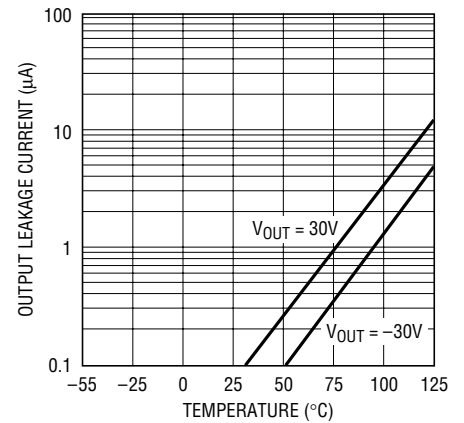

1080/81 G09

Output Waveforms

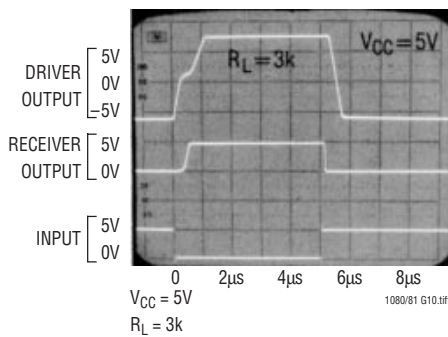

Shutdown to Driver Output

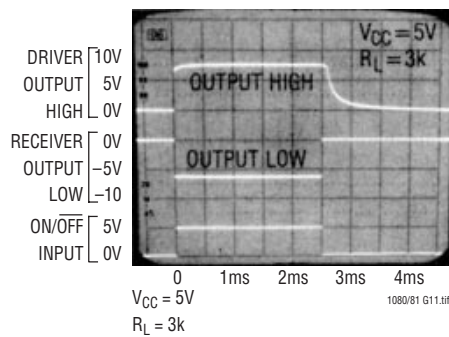

Shutdown to Receiver Output

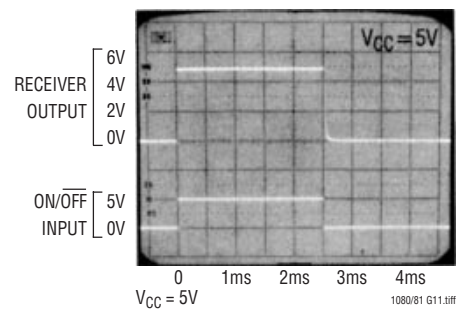

## APPLICATIONS INFORMATION

The driver output stage of the LT1080 offers significantly improved protection over older bipolar and CMOS designs. In addition to current limiting, the driver output can be externally forced to  $\pm 30V$  with no damage or excessive current flow, and will not disrupt the supplies. Some drivers have diodes connected between the outputs and the supplies, so externally applied voltages can cause excessive supply voltage to develop.

Placing the LT1080 in the SHUTDOWN mode (Pin 18 low) puts both the driver and receiver outputs in a high impedance state. This allows data line sharing and transceiver applications.

The SHUTDOWN mode also drops input supply current ( $V_{CC}$ ; Pin 17) to zero for power-conscious systems.

**LT1080/LT1081 Driver**

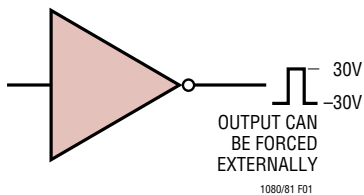

**Older RS232 Drivers and CMOS Drivers**

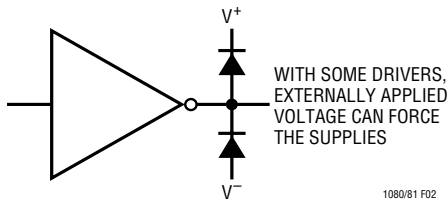

**Transceiver**

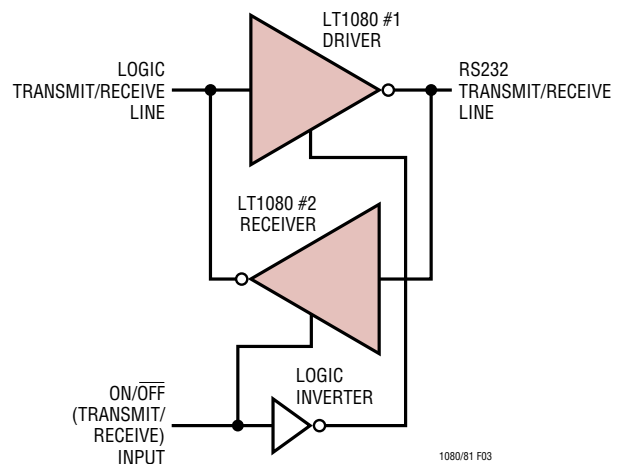

**Sharing a Receiver Line**

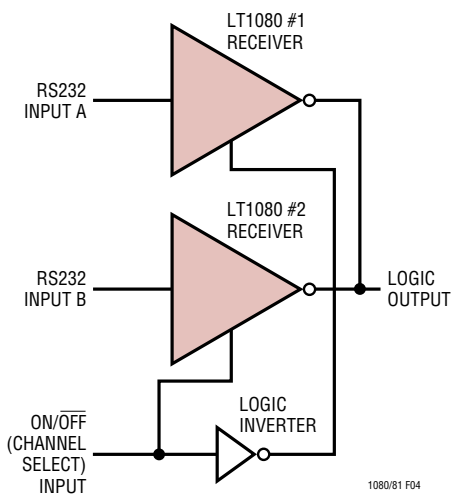

**Sharing a Transmitter Line**

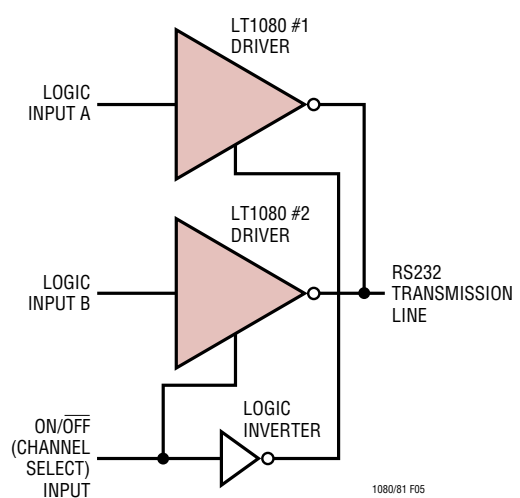

## APPLICATIONS INFORMATION

When driving CMOS logic from a receiver that will be used in the SHUTDOWN mode and there is no other active receiver on the line, a 51k resistor can be placed from the logic input to  $V_{CC}$  to force a definite logic level when the receiver output is in a high impedance state.

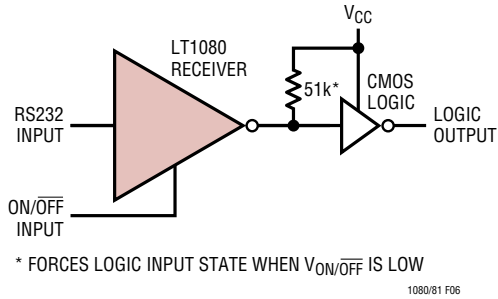

The generated driver supplies ( $V^+$  and  $V^-$ ) may be used to power external circuitry such as other RS232 drivers or op amps. They should be loaded with care, since excessive loading can cause the generated supply voltages to drop, causing the RS232 driver output voltages to fall below RS232 requirements. See the graph "Supply Generator Outputs" for a comparison of generated supply voltage versus supply current.

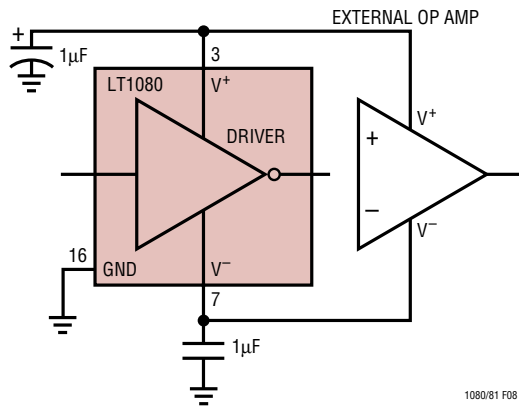

To protect against receiver input overloads in excess of  $\pm 30V$ , a voltage clamp can be placed on the data line and still maintain RS232 compatibility.

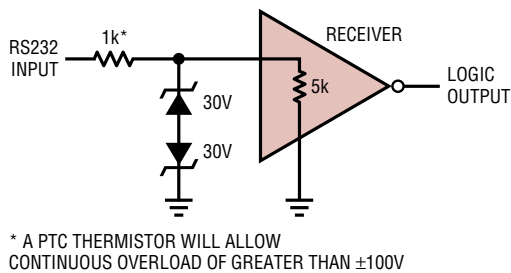

## TYPICAL APPLICATION

Operating with 5V and 12V

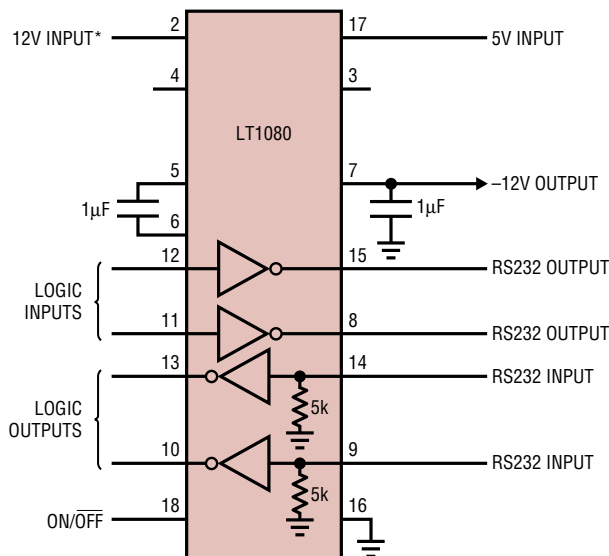

\* PIN 1 USED ON LT1081.

1080/81 • TA03

10801fe

**PACKAGE DESCRIPTION**

**J Package**  
**16-Lead CERDIP (Narrow .300 Inch, Hermetic)**  
 (Reference LTC DWG # 05-08-1110)

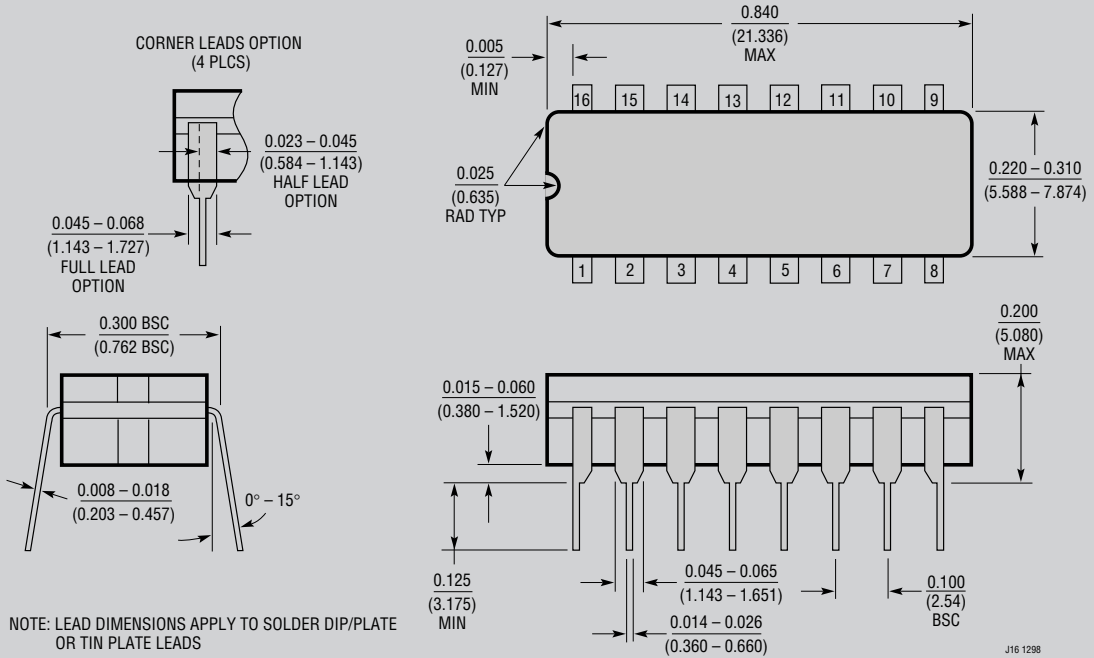

**J Package**  
**18-Lead CERDIP (Narrow .300 Inch, Hermetic)**  
 (Reference LTC DWG # 05-08-1110)

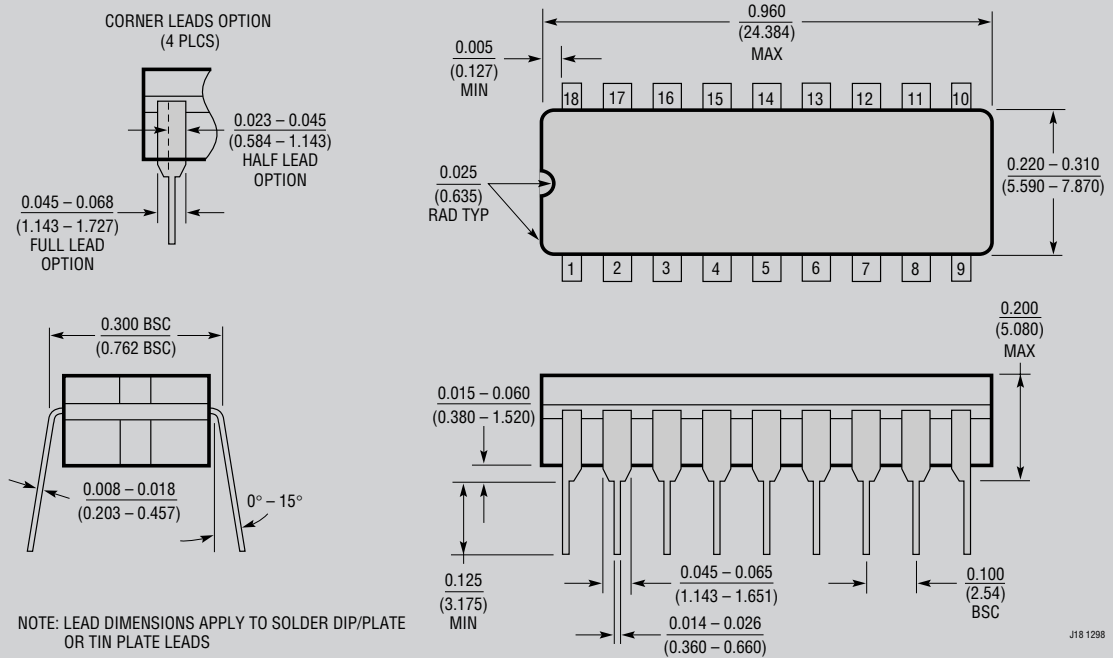

**OBsolete PACKAGES**

**PACKAGE DESCRIPTION**

**N Package**  
**16-Lead PDIP (Narrow .300 Inch)**  
 (Reference LTC DWG # 05-08-1510)

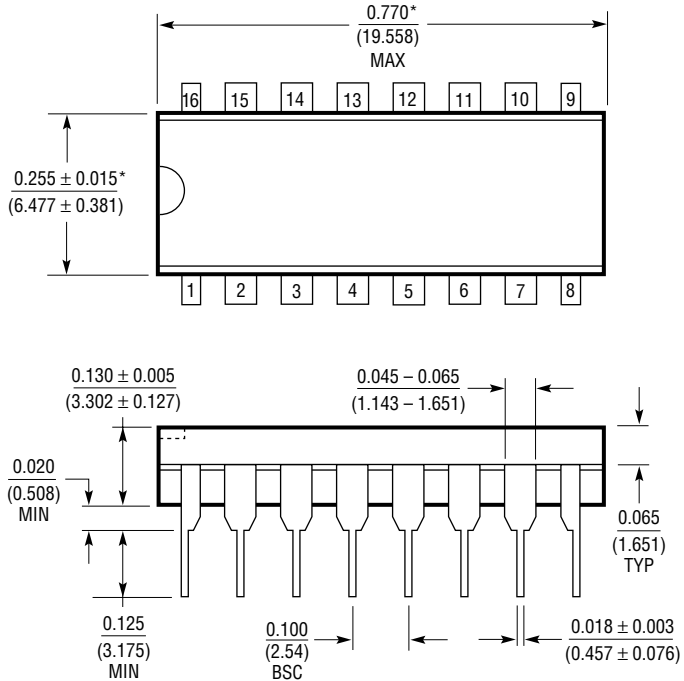

\*THESE DIMENSIONS DO NOT INCLUDE MOLD FLASH OR PROTRUSIONS.  
 MOLD FLASH OR PROTRUSIONS SHALL NOT EXCEED 0.010 INCH (0.254mm)

N16 1098

**N Package**  
**18-Lead PDIP (Narrow .300 Inch)**  
 (Reference LTC DWG # 05-08-1510)

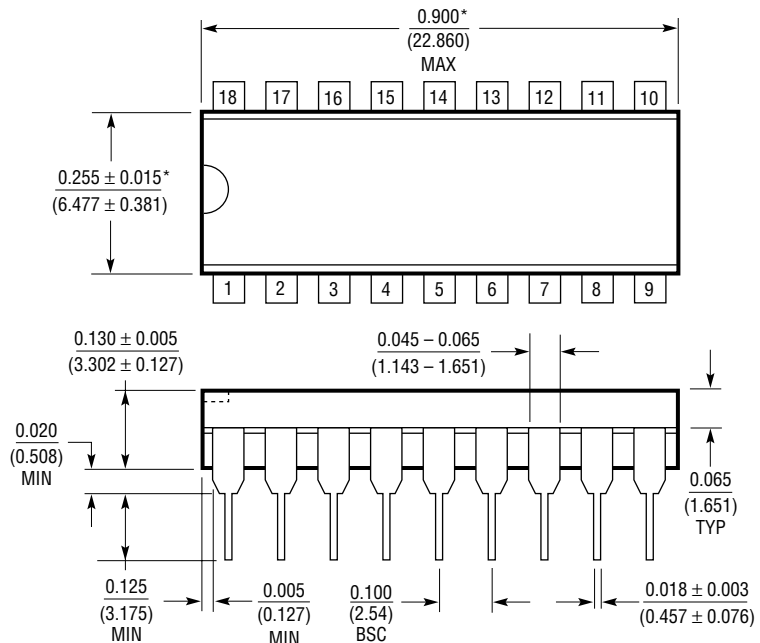

\*THESE DIMENSIONS DO NOT INCLUDE MOLD FLASH OR PROTRUSIONS.  
 MOLD FLASH OR PROTRUSIONS SHALL NOT EXCEED 0.010 INCH (0.254mm)

N18 1098

10801fe

**PACKAGE DESCRIPTION**

**SW Package**  
**16-Lead Plastic Small Outline (Wide .300 Inch)**  
 (Reference LTC DWG # 05-08-1620)

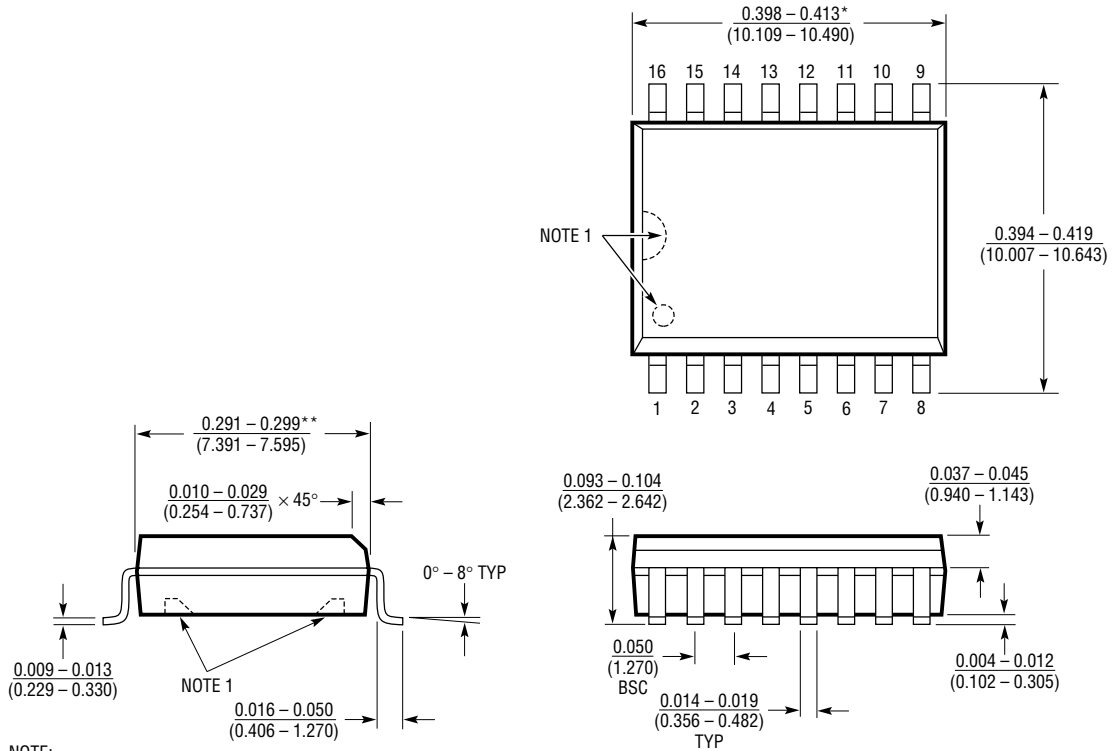

NOTE:  
 1. PIN 1 IDENT, NOTCH ON TOP AND CAVITIES ON THE BOTTOM OF PACKAGES ARE THE MANUFACTURING OPTIONS.  
 THE PART MAY BE SUPPLIED WITH OR WITHOUT ANY OF THE OPTIONS

\*DIMENSION DOES NOT INCLUDE MOLD FLASH. MOLD FLASH SHALL NOT EXCEED 0.006" (0.152mm) PER SIDE  
 \*\*DIMENSION DOES NOT INCLUDE INTERLEAD FLASH. INTERLEAD FLASH SHALL NOT EXCEED 0.010" (0.254mm) PER SIDE

S16 (WIDE) 1098

# PACKAGE DESCRIPTION

**SW Package**  
**18-Lead Plastic Small Outline (Wide .300 Inch)**  
 (Reference LTC DWG # 05-08-1620)

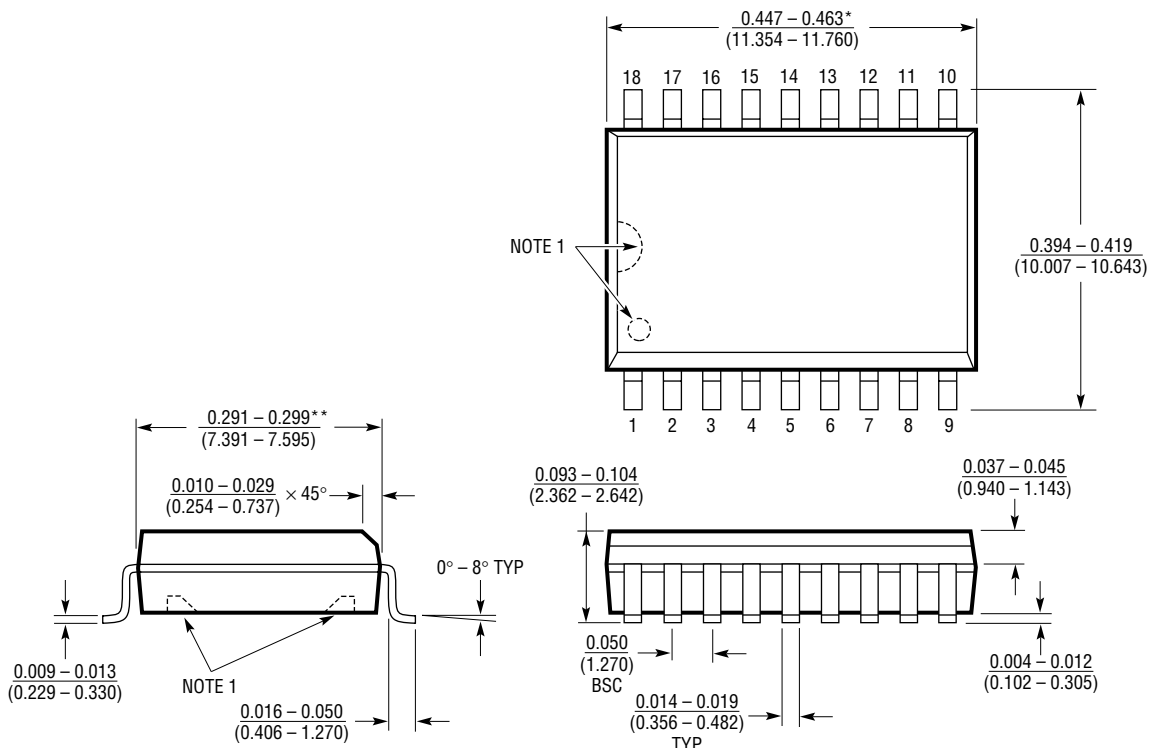

NOTE:  
 1. PIN 1 IDENT. NOTCH ON TOP AND CAVITIES ON THE BOTTOM OF PACKAGES ARE THE MANUFACTURING OPTIONS. THE PART MAY BE SUPPLIED WITH OR WITHOUT ANY OF THE OPTIONS  
 \*DIMENSION DOES NOT INCLUDE MOLD FLASH. MOLD FLASH SHALL NOT EXCEED 0.006" (0.152mm) PER SIDE  
 \*\*DIMENSION DOES NOT INCLUDE INTERLEAD FLASH. INTERLEAD FLASH SHALL NOT EXCEED 0.010" (0.254mm) PER SIDE

S18 (WIDE) 1098

## TYPICAL APPLICATION

Supporting an LT1039 (Triple Driver/Receiver)

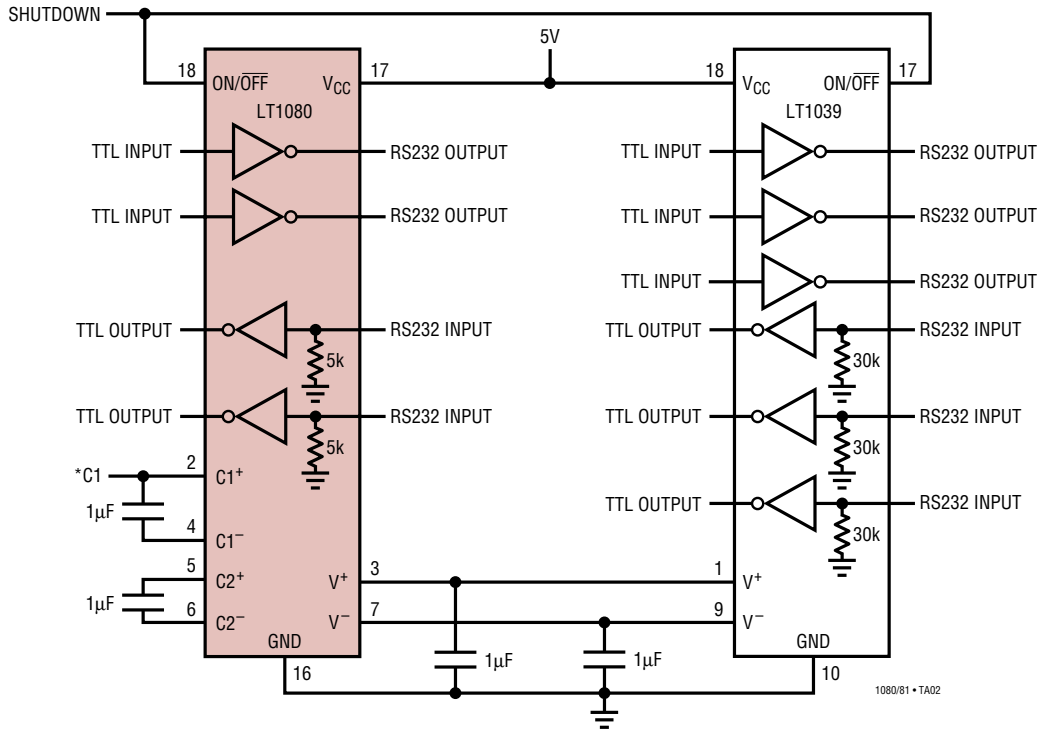

\*IN APPLICATIONS WHERE A SEPARATE SECOND POSITIVE SUPPLY IS AVAILABLE (SUCH AS 5V AND 12V), THE 12V SUPPLY MAY BE CONNECTED TO PIN 2 AND C1 DELETED. THE POWER SUPPLY CIRCUITRY WILL THEN INVERT THE 12V SUPPLY. THE 5V SUPPLY IS STILL NEEDED TO POWER THE BIASING CIRCUITRY AND RECEIVERS.

## RELATED PARTS

PART NUMBER	DESCRIPTION	COMMENTS
LT1180A/LT1181A	5V Low Power 2DR/2TX RS232 Transceiver	0.1µF Capacitors, 10kV ESD
LT1780/LT1781	5V Low Power 2DR/2TX RS232 Transceiver	15kV ESD
LT1381	5V Low Power 2DR/2TX RS232 Transceiver	16-Pin Narrow SO Package
LT1130A/LT1140A	5V RS232 Transceivers	Up to 5DR/5RX
LTC1383	5V Low Power 2DR/2RX RS232 Transceiver	Low Supply Current $I_{CC} = 220\mu A$
LTC1386	3.3V Low Power EIA/TIA562 Transceiver	Low Supply Current $I_{CC} = 200\mu A$

## Looking for pricing, stock, or lifecycle information?

Click below to explore more details on WIN SOURCE:

 [View LT1080CSW#PBF on WIN SOURCE](#)

 [Linear Technology](#) Information

## Optimize Your Supply Chain with WIN SOURCE Solutions

-  Global Sourcing Solution
-  Obsolete Management
-  Cost Control Management
-  Shortage Management
-  Alternative Solution
-  Excess Inventory Management