



**THE DATASHEET OF  
LT1039CN16**



## FEATURES

- Operates from  $\pm 5V$  to  $\pm 15V$  Supplies
- Fully Protected Against Overload
- Outputs Can Be Driven  $\pm 30V$  Without Damage
- Three-State Outputs; Outputs Open When Off
- Bipolar Circuit—No Latchup
- $\pm 30V$  Input Range
- Triple Driver/Receiver
- No Supply Current in Shutdown
- $30k\Omega$  Input Impedance
- Meets All RS232 Specifications
- 16-Pin Version—Pin Compatible with MC145406
- Available in SO Package
- 15kV ESD: LT1039A

## APPLICATIONS

- RS232 Interface
- Terminals
- Modems

## DESCRIPTION

The LT<sup>®</sup>1039 is a triple RS232 driver/receiver that includes shutdown. Each receiver will accept up to  $\pm 30V$  input and can drive either TTL or CMOS logic. The RS232 drivers accept TTL logic inputs and output RS232 voltage levels. The outputs are fully protected against overload and can be shorted to ground or up to  $\pm 30V$  without damage to the drivers. Additionally, when the system is shut down or power is off, the outputs are in a high impedance state allowing data line sharing. Bipolar circuitry makes this driver/receiver exceptionally rugged against overloads and immune to latchup.

A BIAS pin allows one receiver to be kept on while the rest of the part is shut down.

The LT1039 is also available in the 16-pin version, without shutdown or BIAS pin functions.

For applications requiring operation from a single 5V supply, see the LT1080/LT1081, LT1180A/LT1181A and LT1130A data sheets. For applications requiring 15kV ESD, see the LT1039A.

LT, LTC and LT are registered trademarks of Linear Technology Corporation.

## TYPICAL APPLICATION

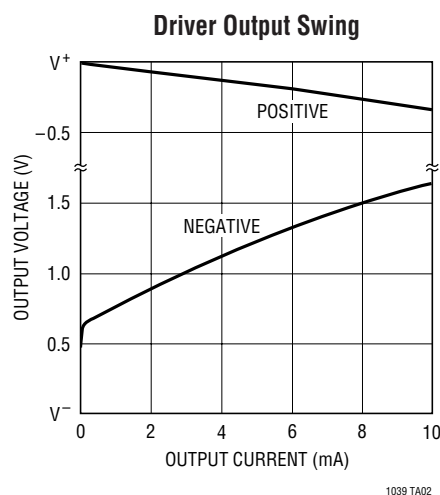
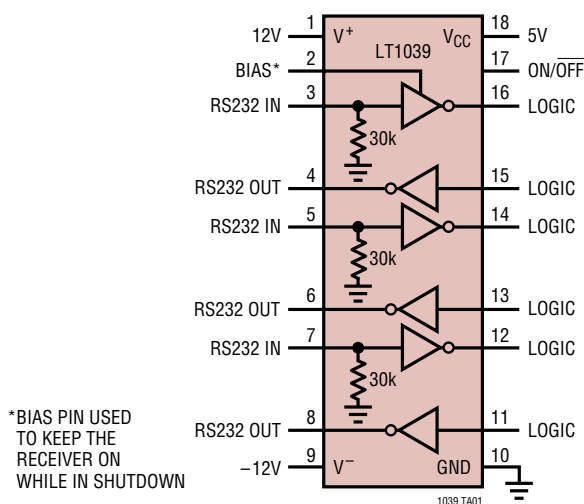

## ABSOLUTE MAXIMUM RATINGS (Note 1)

Supply Voltage		Short-Circuit Duration	Indefinite
Driver ( $V^+$ , $V^-$ )	$\pm 16V$	Operating Temperature Range	
Receiver ( $V_{CC}$ )	7V	LT1039C	0°C to 70°C
Logic Inputs	$V^-$ to 25V	LT1039I	-40°C to 85°C
Receiver Inputs	$\pm 30$	LT1039M	-55°C to 125°C
ON/OFF Input	GND to 12V	Storage Temperature Range	-65°C to 150°C
Driver Outputs	( $V^- + 30V$ ) to ( $V^+ - 30V$ )	Lead Temperature (Soldering, 10 sec)	300°C

## PACKAGE/ORDER INFORMATION

TOP VIEW	ORDER PART NUMBER	TOP VIEW	ORDER PART NUMBER
<p>N PACKAGE 16-LEAD PDIP</p> <p>SW PACKAGE 16-LEAD PLASTIC SO WIDE</p> <p><math>T_{JMAX} = 150^\circ C, \theta_{JA} = 140^\circ C/W</math> (N) <math>T_{JMAX} = 150^\circ C, \theta_{JA} = 150^\circ C/W</math> (SW)</p>	<p>LT1039CN16 LT1039CSW16</p> <p>CONSULT FACTORY FOR AVAILABILITY</p>	<p>N PACKAGE 18-LEAD PDIP</p> <p>SW PACKAGE 18-LEAD PLASTIC SO WIDE</p> <p><math>T_{JMAX} = 150^\circ C, \theta_{JA} = 120^\circ C/W</math> (N) <math>T_{JMAX} = 150^\circ C, \theta_{JA} = 120^\circ C/W</math> (SW)</p>	<p>LT1039CN LT1039CSW LT1039IN LT1039ISW</p>
<p>J PACKAGE 16-LEAD CERDIP</p> <p><math>T_{JMAX} = 150^\circ C, \theta_{JA} = 100^\circ C/W</math> (J)</p>	<p>LT1039MJ16</p>	<p>J PACKAGE 18-LEAD CERDIP</p> <p><math>T_{JMAX} = 150^\circ C, \theta_{JA} = 100^\circ C/W</math> (J)</p>	<p>LT1039CJ LT1039MJ</p>
<p><b>OBsolete PACKAGES</b> Consider the N Package for Alternate Source</p>			

## ELECTRICAL CHARACTERISTICS

The ● denotes specifications which apply over the full operating temperature range, otherwise specifications are at  $T_A = 25^\circ C$ .

PARAMETER	CONDITIONS	MIN	TYP	MAX	UNITS
<b>Driver <math>V^+ = 12V</math>, <math>V^- = -12V</math>, <math>V_{ON/OFF} = 2.5V</math> (Note 2)</b>					
Output Voltage Swing	Load = 3k to Ground Positive Negative	● $V^+ - 0.4$ ● $V^- + 1.5$	$V^+ - 0.1$ $V^- + 1.0$		V
Logic Input Voltage Levels	Input Low Level ( $V_{OUT} = High$ ) Input High Level ( $V_{OUT} = Low$ )	● ●	1.4 1.4	0.8	V
Logic Input Current	$V_{IN} \geq 2.0V$ $V_{IN} \leq 0.8V$		1 5	20 20	$\mu A$
Output Short-Circuit Current	Sourcing Current, $V_{OUT} = 0V$ Sinking Current, $V_{OUT} = 0V$	5 -5	15 -15		mA
Output Leakage Current	Shutdown (Notes 3, 4), $V_{OUT} = \pm 18V$ , $V_{IN} = 0V$	●	10 (25°C)	200	$\mu A$
Supply Leakage Current	Shutdown (Note 3)	●	1 (25°C)	100	$\mu A$
Slew Rate	$R_L = 3k$ , $C_L = 51pF$	4	15	30	V/ $\mu s$
Supply Current	$V_{OUT} = Low$		4	8	mA

1039fd

## ELECTRICAL CHARACTERISTICS

The ● denotes specifications which apply over the full operating temperature range, otherwise specifications are at  $T_A = 25^\circ\text{C}$ .

PARAMETER	CONDITIONS		MIN	TYP	MAX	UNITS
<b>Receiver <math>V_{CC} = 5\text{V}</math>, <math>V_{ON/OFF} = 2.5\text{V}</math> (Note 2)</b>						
Input Voltage Thresholds	Input Low Level ( $V_{OUT} = \text{High}$ )	●	0.5	1.3		V
	Input High Level ( $V_{OUT} = \text{Low}$ )	●		1.7	2.8	V
Hysteresis		●	0.1	0.4	1.0	V
Input Resistance		●		30		k $\Omega$
Output Voltage	Output Low, $I_{OUT} = -1.6\text{mA}$	●		0.4	0.5	V
	Output High, $I_{OUT} = 160\mu\text{A}$	●	3.5	4.8		V
Output Short-Circuit Current	Sourcing Current, $V_{OUT} = 0\text{V}$ (Note 5)	●	0.5	1		mA
	Sinking Current, $V_{OUT} = V_{CC}$	●	-10			mA
Output Leakage Current	Shutdown (Note 2), $0\text{V} \leq V_{OUT} \leq V_{CC}$ , $V_{IN} = 0\text{V}$	●		1	10	$\mu\text{A}$
Supply Current		●		4	7	mA
Supply Leakage Current	Shutdown (Note 3)	●		1 (25 $^\circ\text{C}$ )	100	$\mu\text{A}$
ON/OFF Pin Current	$0\text{V} \leq V_{ON/OFF} \leq 5\text{V}$	●	-15		80	$\mu\text{A}$

**Note 1:** Absolute Maximum Ratings are those values beyond which the life of a device may be impaired.

**Note 2:**  $V_{ON/OFF} = 5\text{V}$  for LT1039M grade devices.

**Note 3:**  $V_{ON/OFF} = 0.4\text{V}$  for  $-55^\circ\text{C} \leq T_A \leq 100^\circ\text{C}$  and  $V_{ON/OFF} = 0.2\text{V}$  for  $100^\circ\text{C} \leq T_A \leq 125^\circ\text{C}$ . Does not apply to LT1039-16 part.

**Note 4:** For  $T_A \geq 100^\circ\text{C}$ , leakage current is 350 $\mu\text{A}$  max.

**Note 5:** For  $T_A \leq -25^\circ\text{C}$ , output source current is 0.4mA.

## TYPICAL PERFORMANCE CHARACTERISTICS

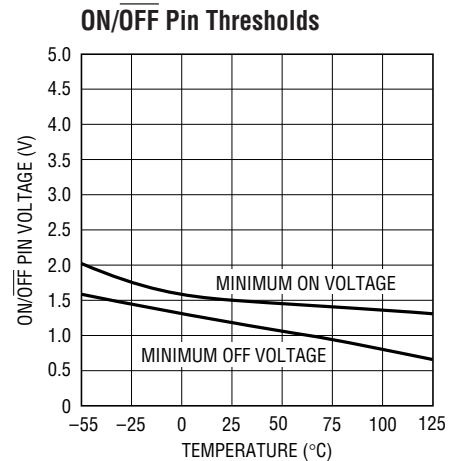
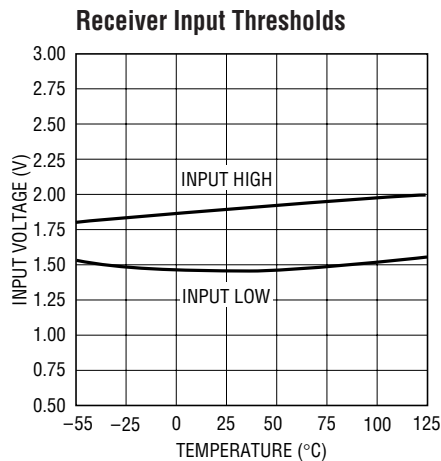
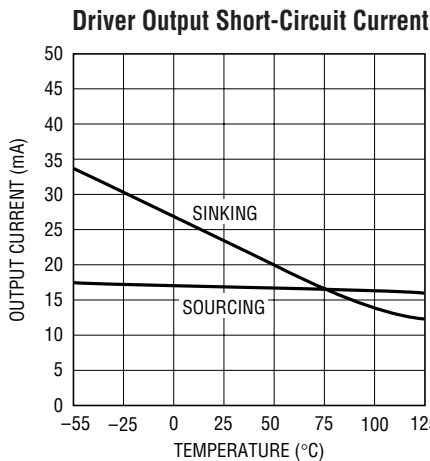

# TYPICAL PERFORMANCE CHARACTERISTICS

**Supply Current in Shutdown**

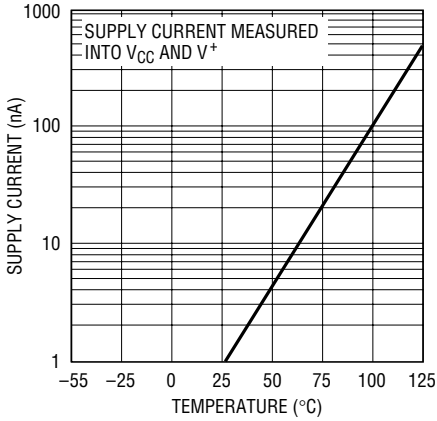

1039 G04

**Driver Output Leakage in Shutdown**

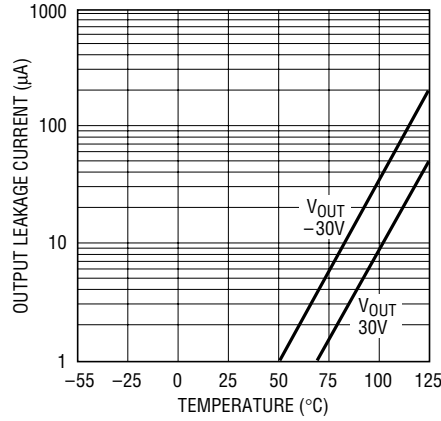

1039 G05

**Receiver Output Short-Circuit Current**

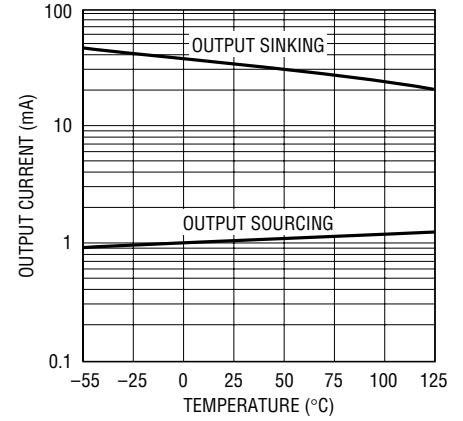

1039 G06

**ON/OFF Pin Current vs Voltage**

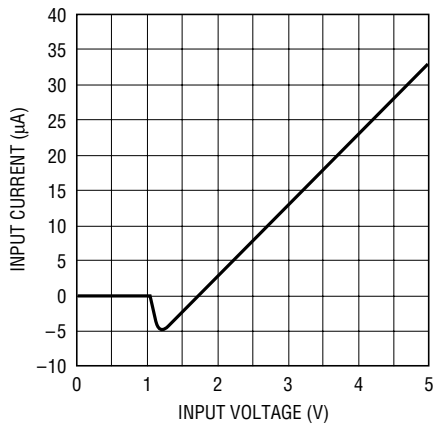

1039 G07

**Driver Output Swing vs Current**

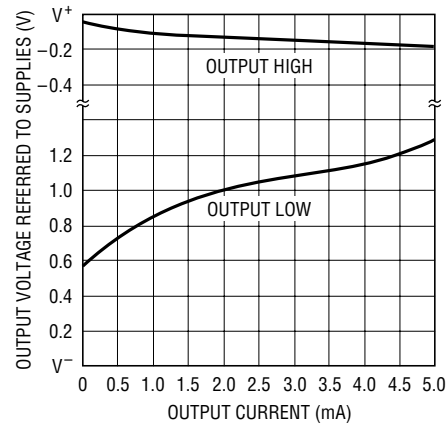

1039 G08

**Output Waveforms**

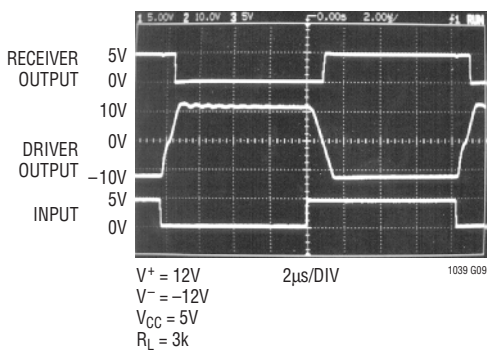

1039 G09

DRIVER OUTPUT CONNECTED TO RECEIVER INPUT

**Shutdown to Driver Output**

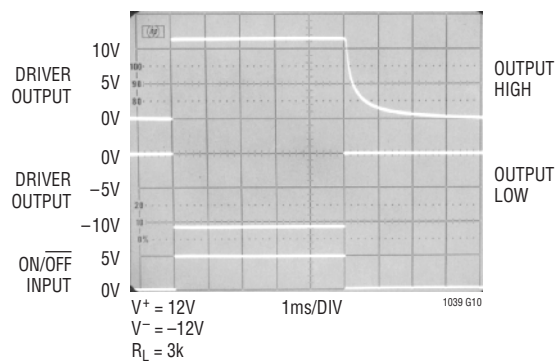

1039 G10

## TYPICAL PERFORMANCE CHARACTERISTICS

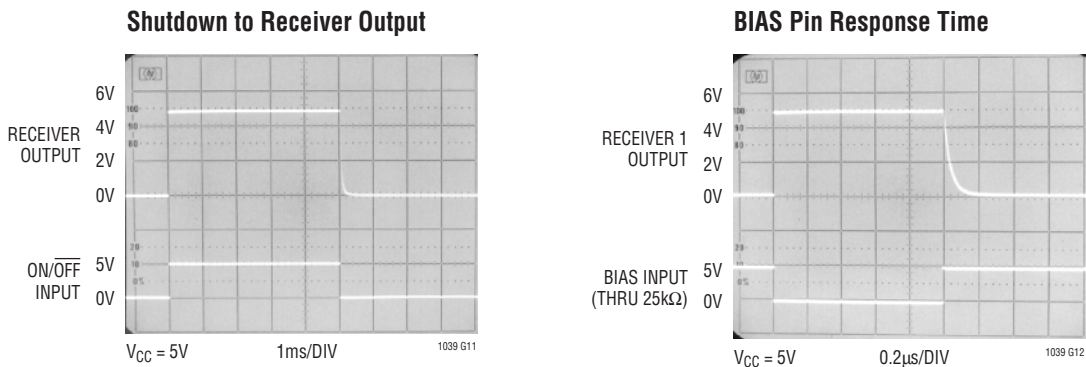

## PIN FUNCTIONS (Pin numbers listed are for 18-pin device)

**V<sup>+</sup>, V<sup>-</sup> (Pins 1, 9):** Driver Supply Pins. Supply current drops to zero in shutdown mode. Driver outputs are in a high impedance state when V<sup>+</sup> and V<sup>-</sup> = 0V.

**BIAS (Pin 2):** Keeps receiver 1 on while the LT1039 is in the shutdown mode. Leave BIAS pin open when not in use. See Applications Information for proper use.

**REC IN (Pins 3, 5, 7):** Receiver Input Pins. Accepts RS232 voltage levels ( $\pm 30V$ ) and has 0.4V of hysteresis to provide noise immunity. Input impedance is nominally 30k $\Omega$ .

**TR OUT (Pins 4, 6, 8):** Driver Outputs with RS232 Voltage Levels. Outputs are in a high impedance state when in the shutdown mode or when power is off (V<sup>+</sup> and V<sup>-</sup> = 0V) to allow data line sharing. Outputs are fully short-circuit protected from V<sup>-</sup> + 30V to V<sup>+</sup> - 30V with power on, off or in the shutdown mode. Typical output breakdowns are greater than  $\pm 45V$  and higher applied voltages will not damage the device if moderately current limited.

**GND (Pin 10):** Ground Pin.

**TR IN (Pins 11, 13, 15):** RS232 Driver Input Pins. Inputs are TTL/CMOS compatible. Inputs should not be allowed to float. Tie unused inputs to V<sub>CC</sub>.

**REC OUT (Pins 12, 14, 16):** Receiver Outputs with TTL/CMOS Voltage Levels. Outputs are in a high impedance state when in the shutdown mode to allow data line sharing. Outputs are fully short-circuit protected to ground or V<sub>CC</sub> with power on, off or in the shutdown mode.

**ON/OFF (Pin 17):** Controls the operation mode of the LT1039 and is TTL/CMOS compatible. A logic low puts the device in the shutdown mode which reduces input supply current to zero and places both driver and receiver outputs in a high impedance state.

**V<sub>CC</sub> (Pin 18):** 5V Power for Receivers.

## APPLICATIONS INFORMATION

The driver output stage of the LT1039 offers significantly improved protection over older bipolar and CMOS designs. In addition to current limiting, the driver output can be externally forced to  $\pm 30V$  with no damage or excessive current flow, and will not disrupt the supplies.

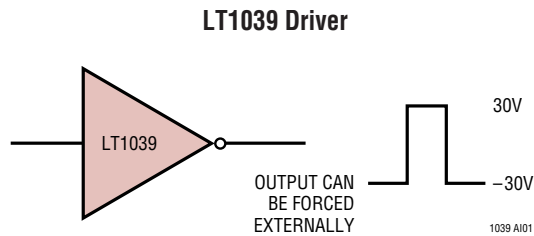

Some drivers have diodes connected between the outputs and the supplies, so externally applied voltages can cause excessive supply voltage to develop

### Older RS232 Drivers and Other CMOS Drivers

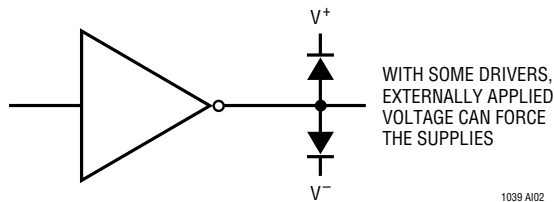

Placing the LT1039 in the shutdown mode (Pin 17 low) puts both the driver and receiver outputs in a high impedance state. This allows data line sharing and transceiver applications.

### Sharing a Transmitter Line

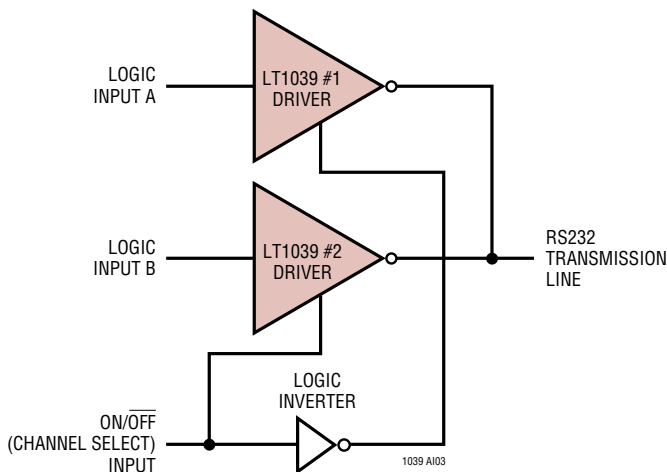

### Sharing a Receiver Line

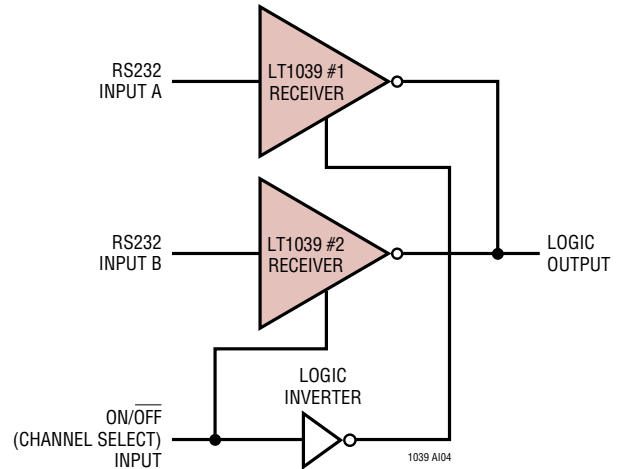

### Transceiver

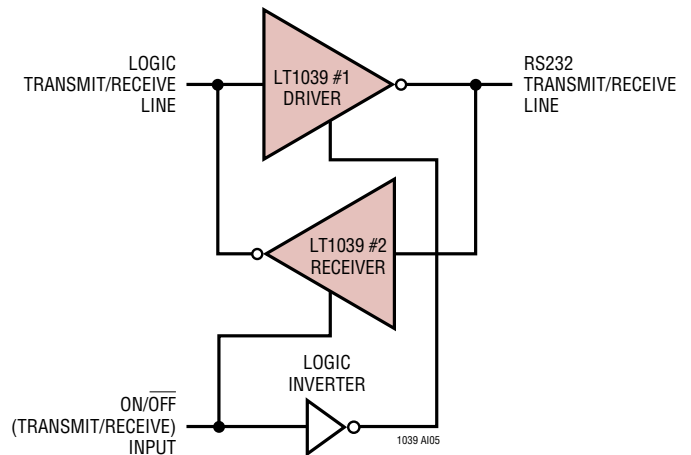

The shutdown mode also drops all supply currents ( $V_{CC}$ ,  $V^+$ ,  $V^-$ ) to zero for power conscious systems.

## APPLICATIONS INFORMATION

When driving CMOS logic from a receiver that will be used in the shutdown mode and there is no other active receiver on the line, a 51k resistor can be placed from the logic input to  $V_{CC}$  to force a definite logic level when the receiver output is in a high impedance state.

### Driving CMOS Logic from a Receiver

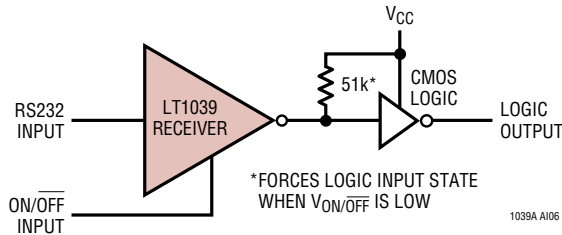

To protect against receiver input overloads in excess of  $\pm 30V$ , a voltage clamp can be placed on the data line and still maintain RS232 compatibility.

### Input Overvoltage Protection

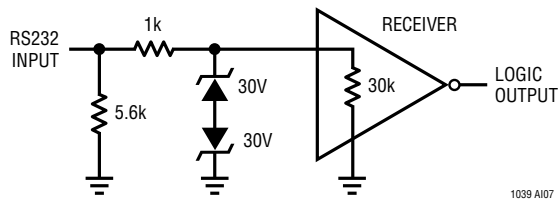

The receiver input impedance of the LT1039 is nominally 30k $\Omega$ . For applications requiring a 5k $\Omega$  input impedance, a 5.6k resistor can be connected from the receiver input to ground.

### 5k $\Omega$ Impedance Matching

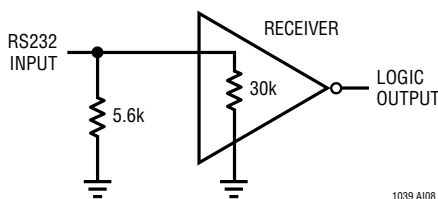

Driver inputs should not be allowed to float. Any unused inputs should be tied to  $V_{CC}$ .

The BIAS pin is used to “keep alive” one receiver while in the shutdown mode (all other circuitry being inactive). This allows a system to be in shutdown and still have one active receiver for transferring data.

### Keeping Alive One Receiver While in Shutdown

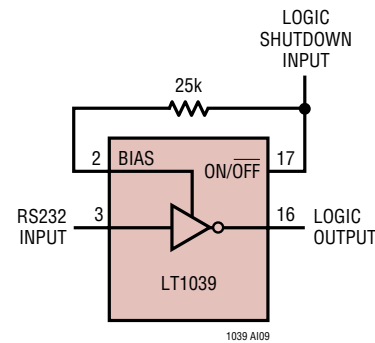

It can also be used to make an RS232 compatible shutdown control line. Driving the BIAS pin low through a resistance of 24k to 30k keeps the receiver active. Do not drive the BIAS pin directly from a logic output without the series resistor. An unused BIAS pin should be left open.

### RS232 Compatible Shutdown Control Line

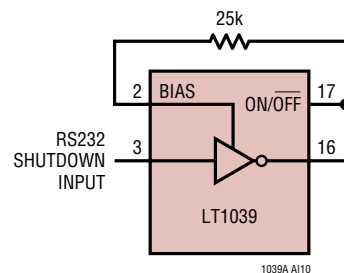

**PACKAGE DESCRIPTION**

**J Package**  
**16-Lead CERDIP (Narrow 0.300, Hermetic)**  
 (LTC DWG # 05-08-1110)

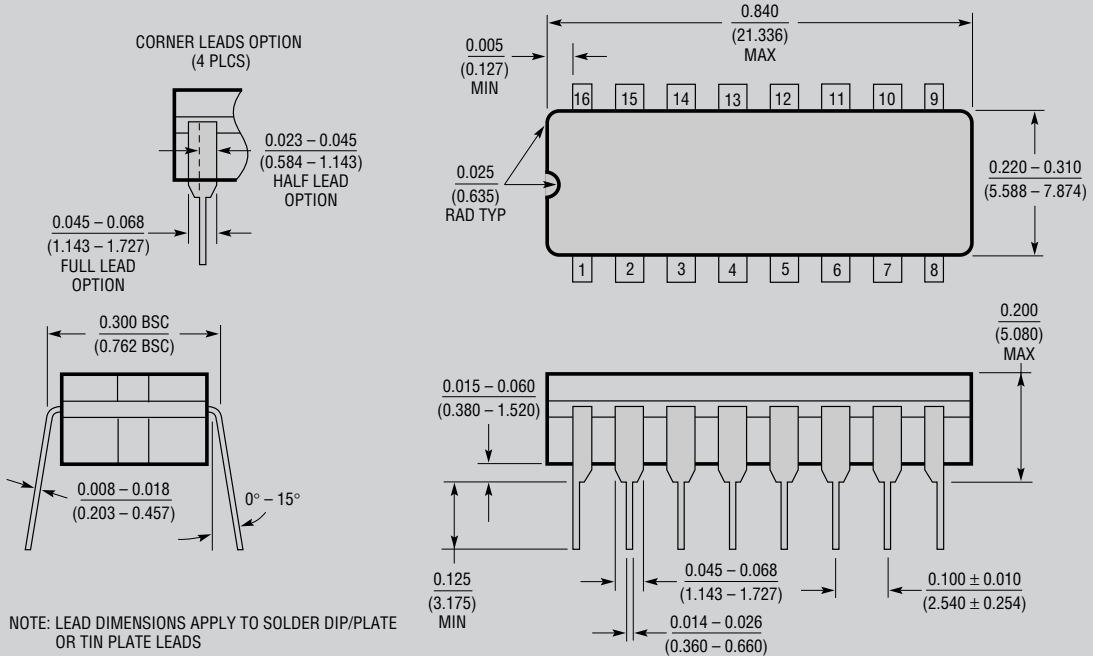

**J Package**  
**18-Lead CERDIP (Narrow 0.300, Hermetic)**  
 (LTC DWG # 05-08-1110)

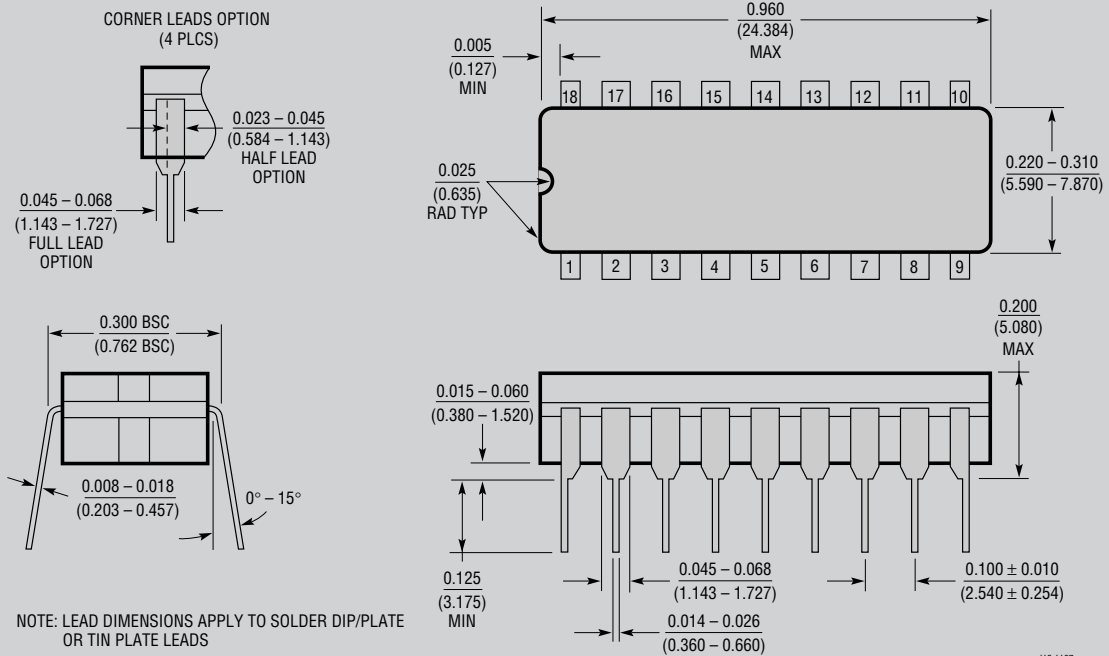

**OBSOLETE PACKAGES**

**PACKAGE DESCRIPTION**

**N Package**  
**16-Lead PDIP (Narrow 0.300)**  
 (LTC DWG # 05-08-1510)

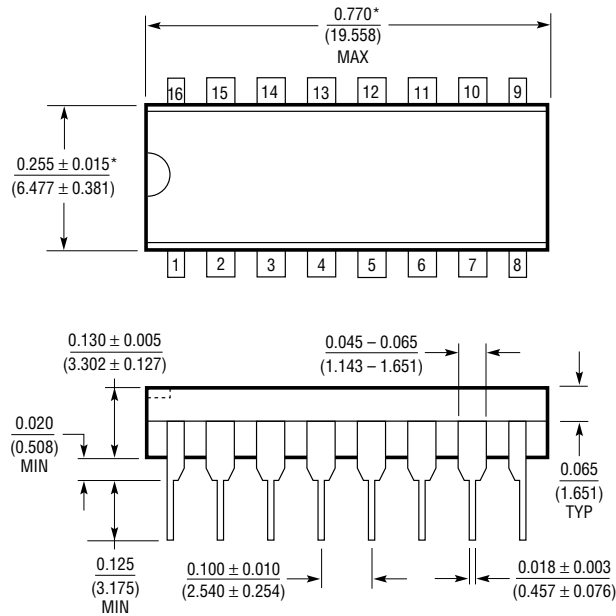

\*THESE DIMENSIONS DO NOT INCLUDE MOLD FLASH OR PROTRUSIONS.  
 MOLD FLASH OR PROTRUSIONS SHALL NOT EXCEED 0.010 INCH (0.254mm)

N16 1197

**N Package**  
**18-Lead PDIP (Narrow 0.300)**  
 (LTC DWG # 05-08-1510)

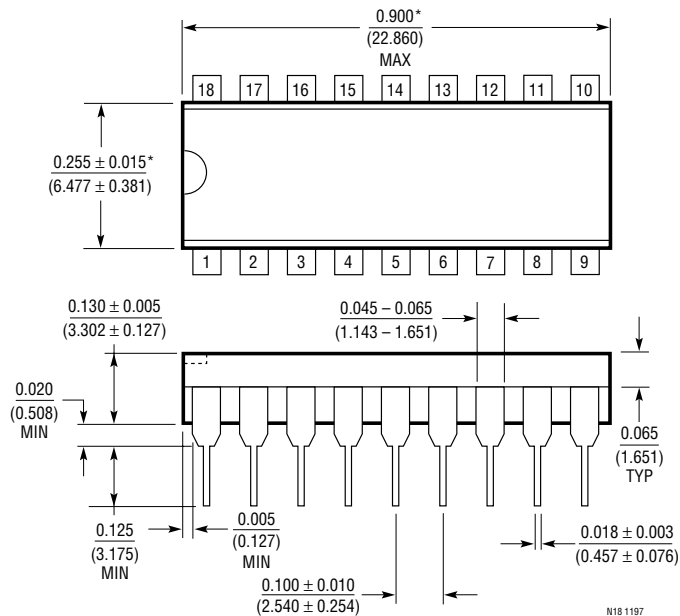

\*THESE DIMENSIONS DO NOT INCLUDE MOLD FLASH OR PROTRUSIONS.  
 MOLD FLASH OR PROTRUSIONS SHALL NOT EXCEED 0.010 INCH (0.254mm)

N18 1197

**PACKAGE DESCRIPTION**

**SW Package**  
**16-Lead Plastic Small Outline (Wide 0.300)**  
 (LTC DWG # 05-08-1620)

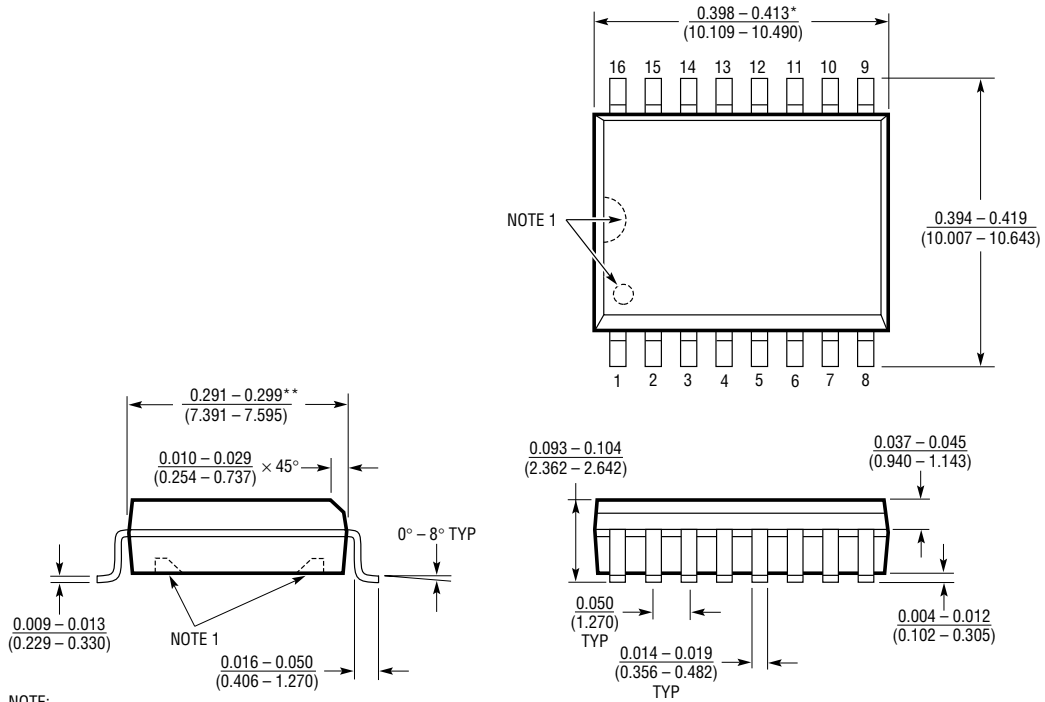

NOTE:  
 1. PIN 1 IDENT, NOTCH ON TOP AND CAVITIES ON THE BOTTOM OF PACKAGES ARE THE MANUFACTURING OPTIONS. THE PART MAY BE SUPPLIED WITH OR WITHOUT ANY OF THE OPTIONS  
 \*DIMENSION DOES NOT INCLUDE MOLD FLASH. MOLD FLASH SHALL NOT EXCEED 0.006" (0.152mm) PER SIDE  
 \*\*DIMENSION DOES NOT INCLUDE INTERLEAD FLASH. INTERLEAD FLASH SHALL NOT EXCEED 0.010" (0.254mm) PER SIDE

S16 (WIDE) 0396

# PACKAGE DESCRIPTION

**SW Package**  
**18-Lead Plastic Small Outline (Wide 0.300)**  
 (LTC DWG # 05-08-1620)

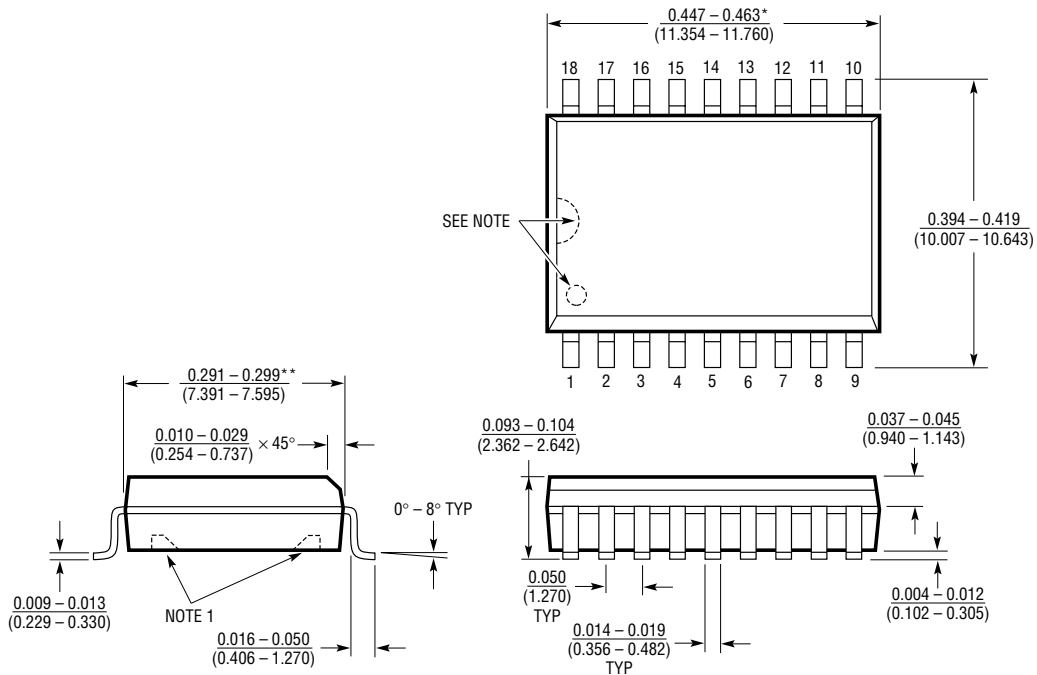

NOTE:  
 1. PIN 1 IDENT. NOTCH ON TOP AND CAVITIES ON THE BOTTOM OF PACKAGES ARE THE MANUFACTURING OPTIONS. THE PART MAY BE SUPPLIED WITH OR WITHOUT ANY OF THE OPTIONS  
 \*DIMENSION DOES NOT INCLUDE MOLD FLASH. MOLD FLASH SHALL NOT EXCEED 0.006" (0.152mm) PER SIDE  
 \*\*DIMENSION DOES NOT INCLUDE INTERLEAD FLASH. INTERLEAD FLASH SHALL NOT EXCEED 0.010" (0.254mm) PER SIDE

S18 (WIDE) 0396

# TYPICAL APPLICATION

LT1080 (Driver/Receiver with Power Supply) Driving an LT1039

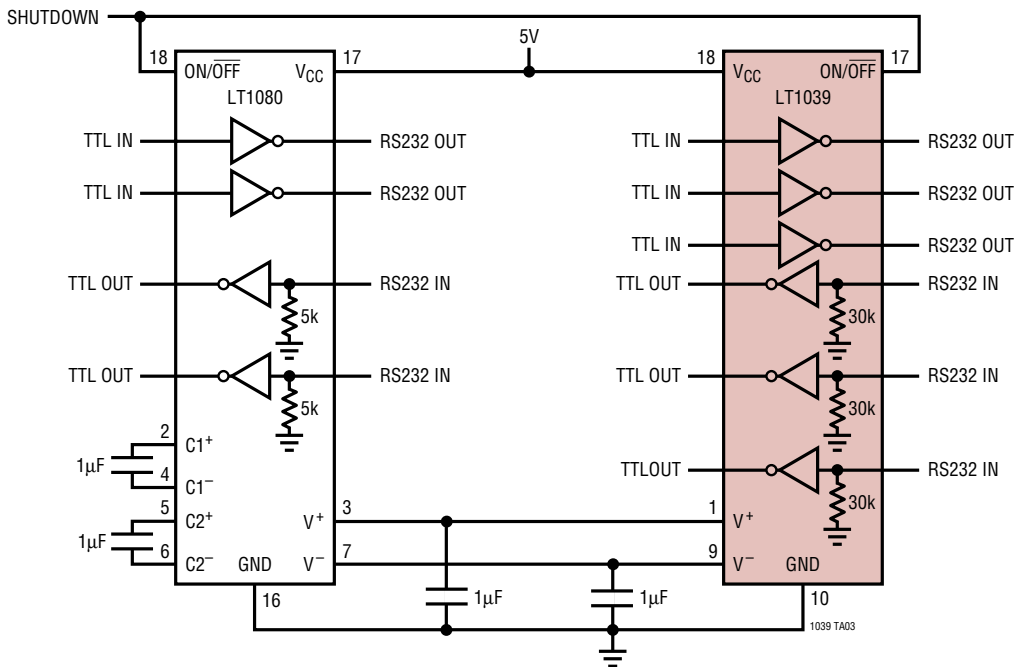

## RELATED PARTS

PART NUMBER	DESCRIPTION	COMMENTS
LTC®485	Low Power RS485 Transceiver	Industry Standard
LT1039A/LT1039A-16	Triple RS232 Driver/Receivers with Shutdown	±15kV ESD Protection
LT1137A	5V 3-Driver/5-Receiver RS232 Transceiver	±15kV ESD Protection
LT1180A/LT1181A	5V 2-Driver/2-Receiver RS232 Transceivers	Industry Standard, 0.1µF Capacitors
LTC1345	V.35 Transceiver	Single 5V Supply Using 0.1µF Capacitors
LTC1348	3.3V 3-Driver/5-Receiver RS232 Transceiver	Operates from 3.3V to 5V Supplies, 5 Receivers Active in Shutdown
LT1780/LT1781	5V 2-Driver/2-Receiver RS232 Transceivers	±15kV ESD Protection, 0.1µF Capacitors
LT1785/LT1791	Half Duplex/Full Duplex RS485 Transceivers	±60V Protected with ±15kV ESD Protection

## Looking for pricing, stock, or lifecycle information?

Click below to explore more details on WIN SOURCE:

 [View LT1039CN16 on WIN SOURCE](#)

 [Linear Technology](#) Information

## Optimize Your Supply Chain with WIN SOURCE Solutions

-  Global Sourcing Solution
-  Obsolete Management
-  Cost Control Management
-  Shortage Management
-  Alternative Solution
-  Excess Inventory Management