



**THE DATASHEET OF
LT1022CN8**



FEATURES

- **Guaranteed** Slew Rate: 23V/ μ s Min
- **Guaranteed** Offset Voltage: 250 μ V Max
–55°C to 125°C: 750 μ V Max
- **Guaranteed** Drift: 5 μ V/°C Max
- **Guaranteed** Bias Current:
70°C, 180pA Max
125°C, 4nA Max
- Gain-Bandwidth Product: 8.5MHz Typ
- Settling Time to 0.05% (10V Step): 0.9 μ s Typ

APPLICATIONS

- Fast D/A Output Amplifiers (12, 14, 16 Bits)
- High Speed Instrumentation
- Fast, Precision Sample and Hold
- Voltage-to-Frequency Converters
- Logarithmic Amplifiers

DESCRIPTION

The LT[®]1022 JFET input operational amplifier combines high speed and precision performance.

A 26V/ μ s slew rate and 8.5MHz gain-bandwidth product are simultaneously achieved with offset voltage of typically 80 μ V, 1.5 μ V/°C drift, bias currents of 50pA at 70°C, 500pA at 125°C. The output delivers 20mA of load current without gain degradation.

The 250 μ V maximum offset voltage specification represents less than 1/2 least significant bit error in a 14-bit, 10V system.

The LT1022A meets or exceeds all OP-16A and OP-16E specifications. It is faster and more accurate without stability problems at cold temperatures.

The LT1022 can be used as the output amplifier for 12-bit current output D/A converters, as shown below.

For a more accurate, lower power dissipation, but slower JFET input op amp, please refer to the LT1055 data sheet.

 LTC and LT are registered trademarks of Linear Technology Corporation.

TYPICAL APPLICATION

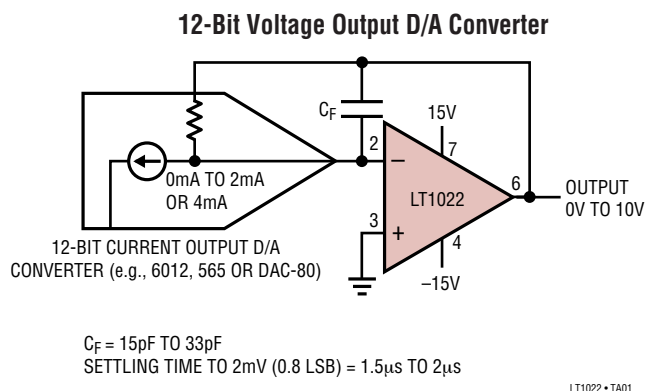

Large-Signal Response

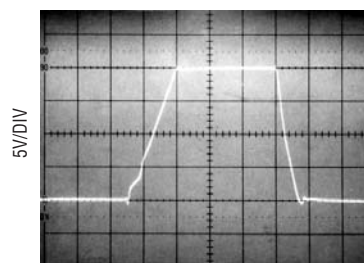

$A_V = 1$
 $C_L = 100\text{pF}$
 $T_A = 25^\circ\text{C}$
 $V_S = \pm 15\text{V}$

LT1022

ABSOLUTE MAXIMUM RATINGS

(Note 1)

Supply Voltage	±20V
Differential Input Voltage	±40V
Input Voltage	±20V
Output Short Circuit Duration	Indefinite

Operating Temperature Range

LT1022AM/1022M (OBSOLETE).....	-55°C to 125°C
LT1022AC/1022C	0°C to 70°C
Storage Temperature Range	-65°C to 150°C
Lead Temperature (Soldering, 10 sec.).....	300°C

PACKAGE/ORDER INFORMATION

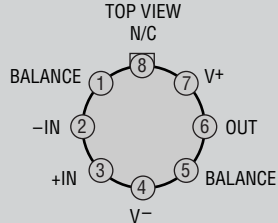
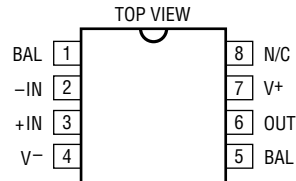
 <p>METAL CAN H PACKAGE $T_{JMAX} = 150^{\circ}\text{C}$, $\theta_{JA} = 150^{\circ}\text{C/W}$, $\theta_{JC} = 45^{\circ}\text{C/W}$</p> <p>OBSOLETE PACKAGE Consider the N8 Package as an Alternate Source</p>	ORDER PART NUMBER	 <p>N8 PACKAGE 8-LEAD PDIP $T_{JMAX} = 100^{\circ}\text{C}$, $\theta_{JA} = 130^{\circ}\text{C/W}$</p>	ORDER PART NUMBER
	LT1022AMH LT1022MH LT1022ACH LT1022CH		LT1022CN8

Consult LTC Marketing for parts specified with wider operating temperature ranges.

ELECTRICAL CHARACTERISTICS

$V_S = \pm 15\text{V}$, $T_A = 25^{\circ}\text{C}$, $V_{CM} = 0\text{V}$ unless otherwise noted.

SYMBOL	PARAMETER	CONDITIONS	LT1022AM LT1022AC			LT1022M, LT1022CH LT1022CN8			UNITS
			MIN	TYP	MAX	MIN	TYP	MAX	
V_{OS}	Input Offset Voltage (Note 2)	H Package N8 Package		80	250		100	600	μV μV
I_{OS}	Input Offset Current	Fully Warmed Up		2	10		2	20	pA
I_B	Input Bias Current	Fully Warmed Up $V_{CM} = +10\text{V}$		±10 30	±50 100		±10 30	±50 150	pA pA
	Input Resistance—Differential —Common Mode	$V_{CM} = -11\text{V}$ to 8V $V_{CM} = 8\text{V}$ to 11V		10^{12} 10^{12} 10^{11}			10^{12} 10^{12} 10^{11}		Ω Ω Ω
	Input Capacitance			4			4		pF
e_n	Input Noise Voltage	0.1Hz to 10Hz		2.5			2.8		$\mu\text{V}/\text{p-p}$
e_n	Input Noise Voltage Density	$f_0 = 10\text{Hz}$ (Note 3) $f_0 = 1\text{kHz}$ (Note 4)		28 14	50 20		30 15	60 22	$\text{nV}/\sqrt{\text{Hz}}$ $\text{nV}/\sqrt{\text{Hz}}$
i_n	Input Noise Current Density	$f_0 = 10\text{Hz}$, 1kHz (Note 5)		1.8	4		1.8	4	$\text{fA}/\sqrt{\text{Hz}}$
A_{VOL}	Large Signal Voltage Gain	$V_0 = \pm 10\text{V}$ $R_L = 2\text{k}$ $R_L = 1\text{k}$	150 130	400 300		120 100	400 300		V/mV V/mV
	Input Voltage Range		±10.5	±12		±10.5	±12		V
CMRR	Common-Mode Rejection Ratio	$V_{CM} = \pm 10.5\text{V}$	86	94		82	92		dB
PSRR	Power Supply Rejection Ratio	$V_S = \pm 10\text{V}$ to $\pm 18\text{V}$	88	104		86	102		dB
V_{OUT}	Output Voltage Swing	$R_L = 2\text{k}$	±12	±13.2		±12	±13.2		V
SR	Slew Rate		23	26		18	24		$\text{V}/\mu\text{s}$

1022fa

ELECTRICAL CHARACTERISTICS

$V_S = \pm 15V$, $T_A = 25^\circ C$, $V_{CM} = 0V$ unless otherwise noted.

SYMBOL	PARAMETER	CONDITIONS	LT1022AM LT1022AC			LT1022M, LT1022CH LT1022CN8			UNITS
			MIN	TYP	MAX	MIN	TYP	MAX	
GBW	Gain-Bandwidth Product	f = 1MHz	8.5			8.0			MHz
I_S	Supply Current		5.2	7.0		5.2	7.0		mA
	Settling Time	A = +1 or A = -1 10V Step to 0.05% 10V Step to 0.02%	0.9 1.3			0.9 1.3			μs μs
	Offset Voltage Adjustment Range	$R_{POT} = 100k$	± 7			± 7			mV

The ● denotes the specifications which apply over the full operating temperature range of $V_{CM} = 0V$, $0^\circ C \leq T_A \leq 70^\circ C$. $V_S = \pm 15V$, unless otherwise noted.

SYMBOL	PARAMETER	CONDITIONS	LT1022AC			LT1022CH LT1022CN8			UNITS
			MIN	TYP	MAX	MIN	TYP	MAX	
V_{OS}	Input Offset Voltage (Note 2)	H Package	●	140	480	180	1000	μV	
		N8 Package	●			300	1700	μV	
	Average Temperature Coefficient of Input Offset Voltage	H Package N8 Package (Note 6)	●	1.3	5.0	1.8	9.0	$\mu V/^\circ C$ $\mu V/^\circ C$	
I_{OS}	Input Offset Current	Warmed Up, $T_A = 70^\circ C$	●	15	80	18	100	pA	
I_B	Input Bias Current	Warmed Up, $T_A = 70^\circ C$	●	± 50	± 200	± 60	± 250	pA	
A_{VOL}	Large-Signal Voltage Gain	$V_O = \pm 10V$, $R_L = 2k$	●	80	250	60	250	V/mV	
CMRR	Common Mode Rejection Ratio	$V_{CM} = \pm 10.4V$	●	85	93	80	91	dB	
PSRR	Power Supply Rejection Ratio	$V_S = \pm 10V$ to $\pm 18V$	●	86	103	84	101	dB	
V_{OUT}	Output Voltage Swing	$R_L = 2k$	●	± 12	± 13.1	± 12	± 13.1	V	

The ● denotes the specifications which apply over the full operating temperature range of $-55^\circ C \leq T_A \leq 125^\circ C$. $V_S = \pm 15V$, $V_{CM} = 0V$, unless otherwise noted.

SYMBOL	PARAMETER	CONDITIONS	LT1022AM			LT1022M			UNITS
			MIN	TYP	MAX	MIN	TYP	MAX	
V_{OS}	Input Offset Voltage	(Note 2)	●	230	750	300	1500	μV	
		(Note 6)	●	1.5	5.0	2.0	9.0	$\mu V/^\circ C$	
I_{OS}	Input Offset Current	Warmed Up, $T_A = 125^\circ C$	●	0.3	2.0	0.30	3.0	nA	
I_B	Input Bias Current	Warmed Up, $T_A = 125^\circ C$	●	± 0.5	± 4.0	± 0.7	± 6.0	nA	
A_{VOL}	Large Signal Voltage Gain	$V_O = \pm 10V$, $R_L = 2k$	●	40	120	35	120	V/mV	
CMRR	Common-Mode Rejection Ratio	$V_{CM} = \pm 10.4V$	●	85	92	80	90	dB	
PSRR	Power Supply Rejection Ratio	$V_S = \pm 10V$ to $\pm 17V$	●	86	102	84	100	dB	
V_{OUT}	Output Voltage Swing	$R_L = 2k$	●	± 12	± 12.9	± 12	± 12.9	V	

Note 1: Absolute Maximum Ratings are those values beyond which the life of a device may be impaired.

Note 2: Offset voltage is measured under two different conditions:
 (a) approximately 0.5 seconds after application of power;
 (b) at $T_A = 25^\circ C$, with the chip self-heated to approximately $45^\circ C$ to account for chip temperature rise when the device is fully warmed up.

Note 3: 10Hz noise voltage density is sample tested on every lot of A grades. Devices 100% tested at 10Hz are available on request.

Note 4: This parameter is tested on a sample basis only.

Note 5: Current noise is calculated from the formula: $i_n = (2qI_B)^{1/2}$, where $q = 1.6 \cdot 10^{-19}$ coulomb. The noise of source resistors up to $1G\Omega$ swamps the contribution of current noise.

Note 6: Offset voltage drift with temperature is practically unchanged when the offset voltage is trimmed to zero with a 100k potentiometer between the balance terminals and the wiper tied to V^+ . Devices tested to tighter drift specifications are available on request.

TYPICAL PERFORMANCE CHARACTERISTICS

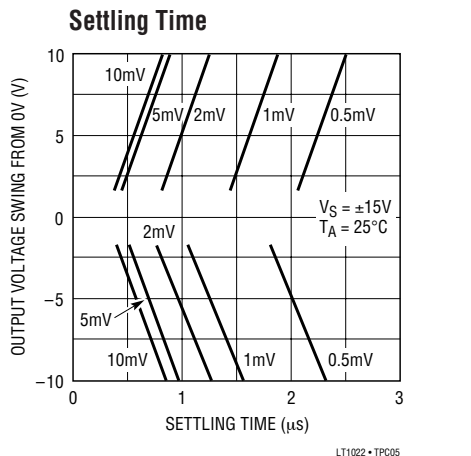
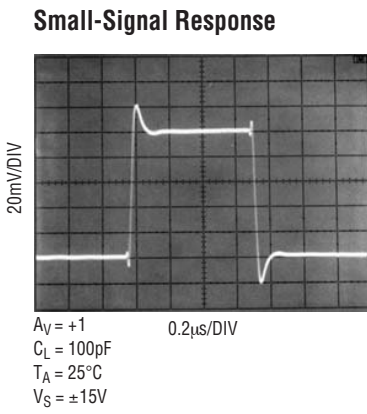
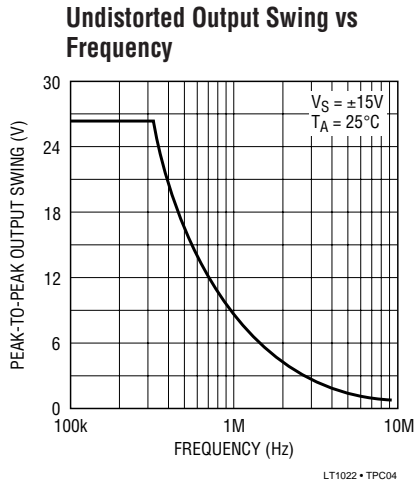
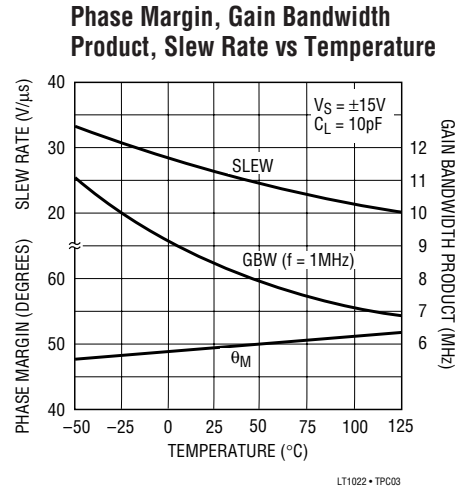
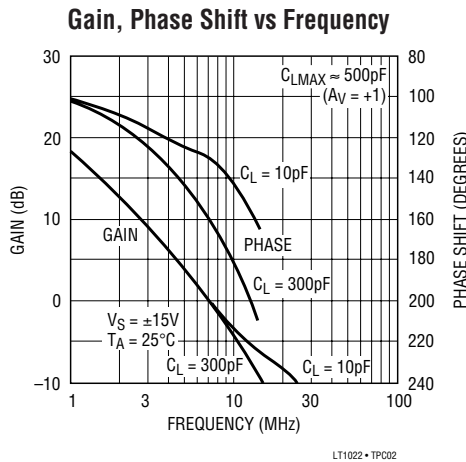
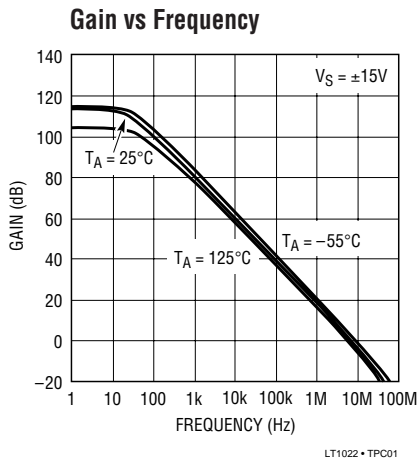

The typical behavior of many LT1022 parameters is identical to the LT1056. Please refer to the LT1055/1056 data sheet for the following typical performance characteristics:

- Input Bias and Offset Currents vs Temperature
- Input Bias Current Over the Common-Mode Range
- Distribution of Input Offset Voltage (H and N8 Package)
- Distribution of Offset Voltage Drift with Temperature
- Warm-Up Drift
- Long Term Drift of Representative Units
- 0.1Hz to 10Hz Noise
- Voltage Noise vs Frequency
- Noise vs Chip Temperature

- Short Circuit Current vs Time
- Output Impedance vs Frequency
- Common Mode Range vs Temperature
- Common Mode and Power Supply Rejections vs Temperature
- Common Mode Rejection Ratio vs Frequency
- Power Supply Rejection Ratio vs Frequency
- Voltage Gain vs Temperature
- Supply Current vs Supply Voltage
- Output Swing vs Load Resistance

APPLICATIONS INFORMATION

The LT1056 applications information is directly applicable to the LT1022. Please consult the LT1055/1056 data sheet for details on:

- (1) plug-in compatibility to industry standard devices
- (2) offset nulling
- (3) achieving picoampere/microvolt performance
- (4) phase-reversal protection
- (5) high speed operation (including settling time test circuit)
- (6) noise performance
- (7) simplified circuit schematic

TYPICAL APPLICATIONS

Fast Piezoelectric Accelerometer

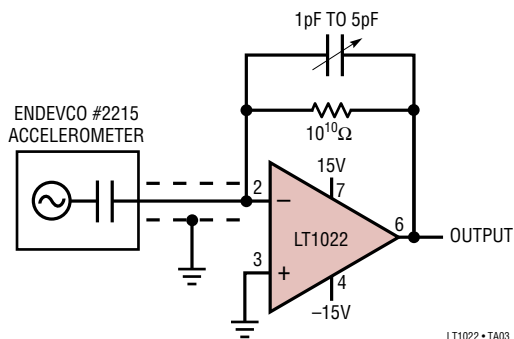

TYPICAL APPLICATIONS

PIN Photodiode-to-Frequency Converter

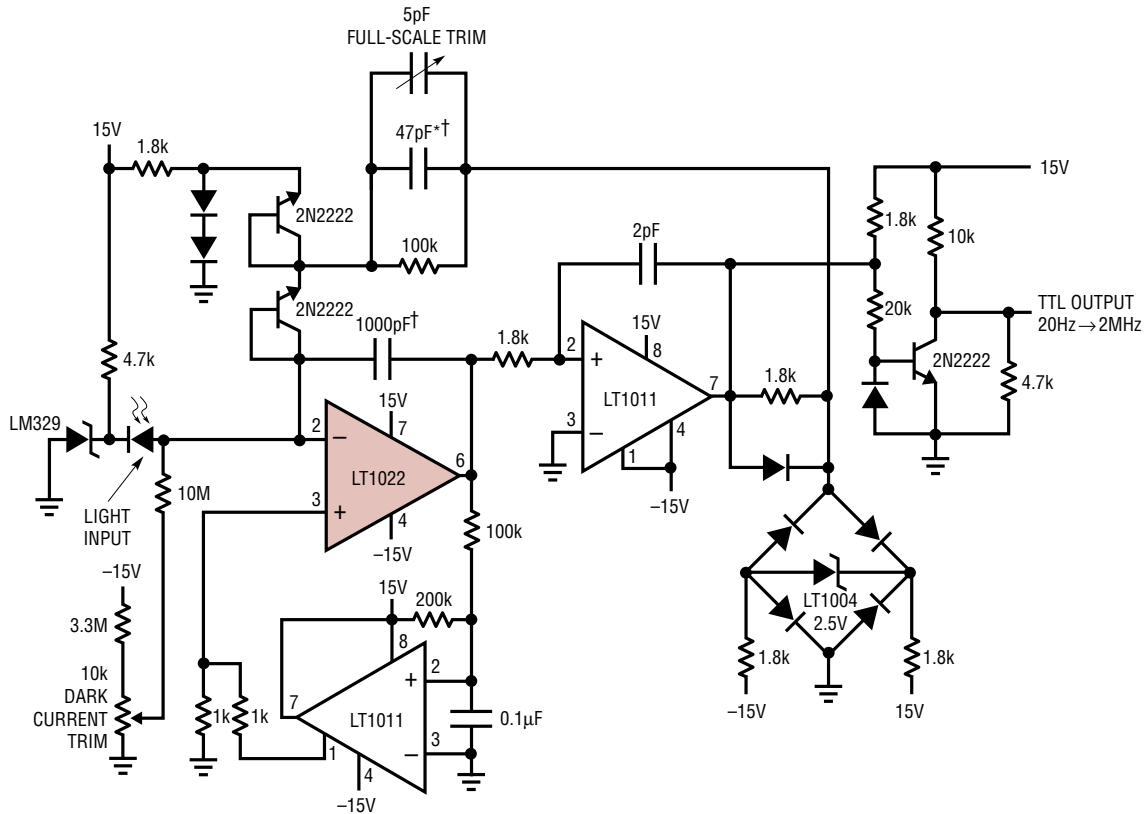

SCALE FACTOR =
1nW/Hz AT 900 NANOMETERS FROM 20nW TO 2mW

= HEWLETT PACKARD PHOTODIODE HP5082-4204

= 1N4148

† POLYSTYRENE

* SELECT VALUE FOR 2mW IN = 2MHz OUT

LT1022 • TA05

TYPICAL APPLICATIONS

Wide Bandwidth Absolute Value Circuit

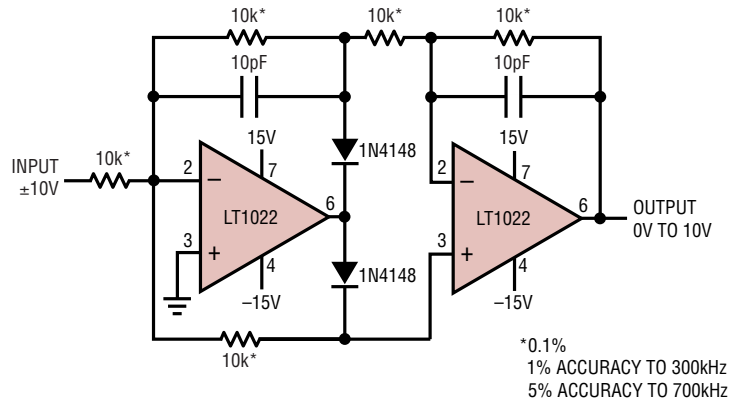

LT1022 • TA06

Fast, Differential Input Current Source

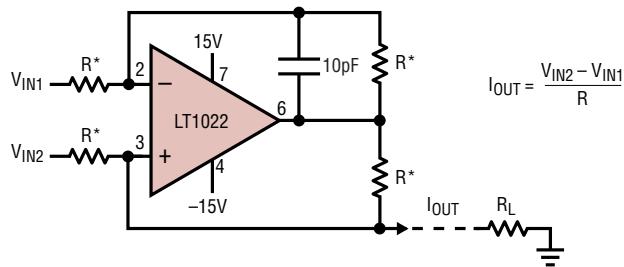

*MATCH TO 0.01%
FULL-SCALE POWER BANDWIDTH
= 1MHz FOR $I_{OUT}R = 8V_{P-P}$
= 400kHz FOR $I_{OUT}R = 20V_{P-P}$
MAXIMUM $I_{OUT} = 10mA_{P-P}$
COMMON-MODE VOLTAGE AT LT1022 INPUT = $\frac{I_{OUT}R \cdot R_L}{2}$

LT1022 • TA07

TYPICAL APPLICATIONS

High Output Current Op Amp

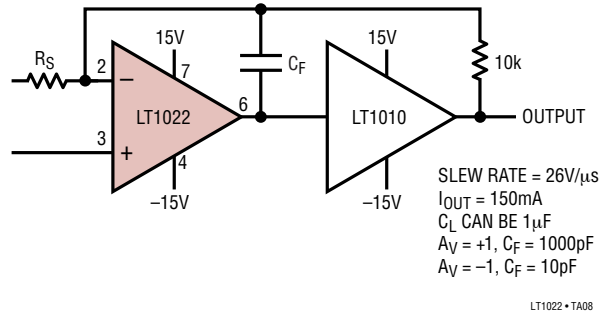

Low Distortion Sine Wave Oscillator

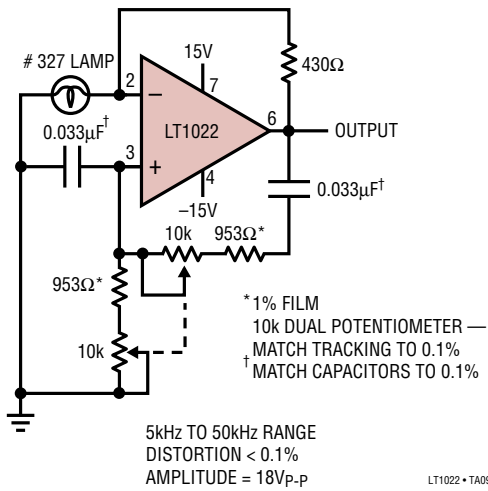

TYPICAL APPLICATIONS

Fast, Precision Sample-And-Hold

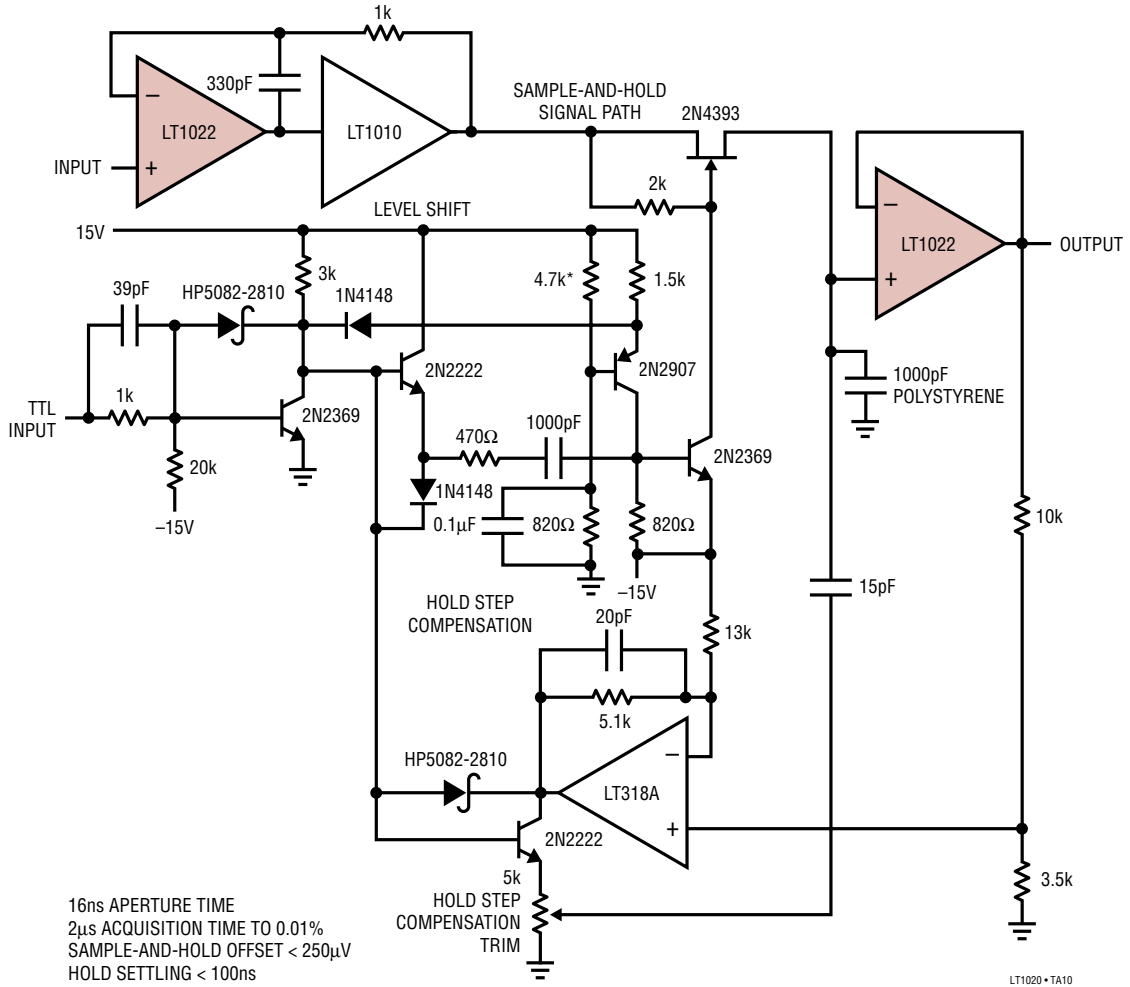

PACKAGE DESCRIPTION

H Package
8-Lead TO-5 Metal Can (.200 Inch PCD)
 (Reference LTC DWG # 05-08-1320)

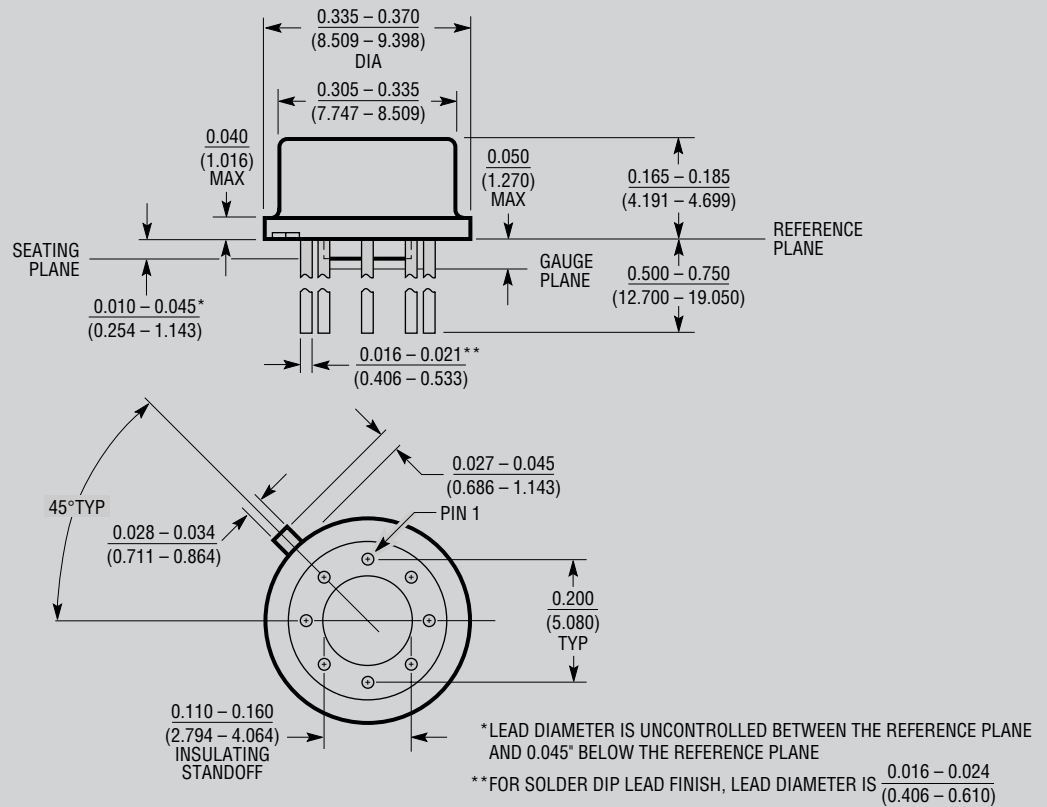

H8(TO-5) 0.200 PCD 1197

OBSOLETE PACKAGE

PACKAGE DESCRIPTION

N8 Package
8-Lead PDIP (Narrow .300 Inch)
 (Reference LTC DWG # 05-08-1510)

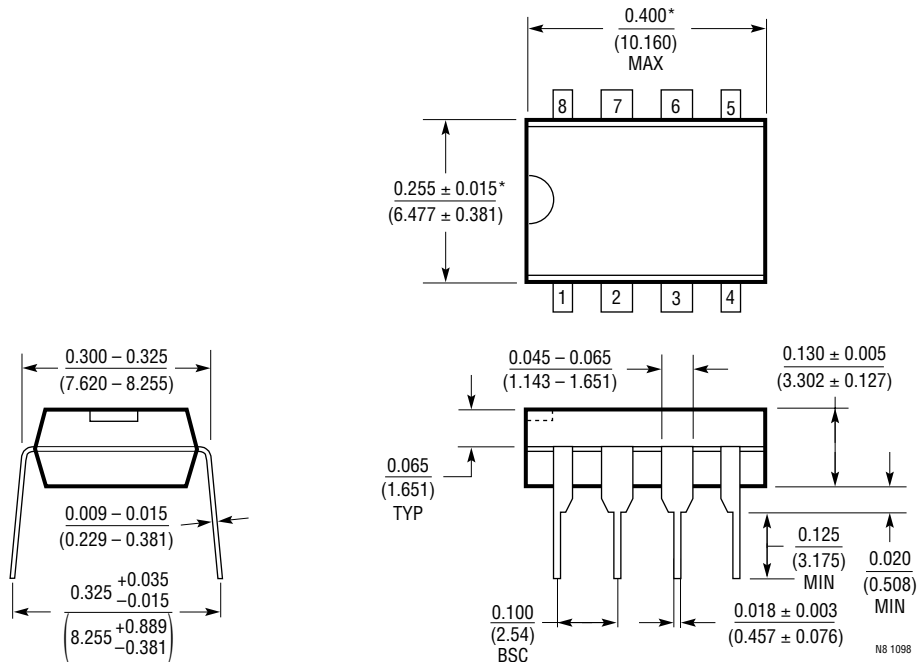

*THESE DIMENSIONS DO NOT INCLUDE MOLD FLASH OR PROTRUSIONS.
 MOLD FLASH OR PROTRUSIONS SHALL NOT EXCEED 0.010 INCH (0.254mm)

Looking for pricing, stock, or lifecycle information?

Click below to explore more details on WIN SOURCE:

 [View LT1022CN8 on WIN SOURCE](#)

 [Linear Technology](#) Information

Optimize Your Supply Chain with WIN SOURCE Solutions

-  Global Sourcing Solution
-  Obsolete Management
-  Cost Control Management
-  Shortage Management
-  Alternative Solution
-  Excess Inventory Management