



THE DATASHEET OF LSF0108PWR



LSF010x 1/2/8 Channel Auto-Bidirectional Multi-Voltage Level Translator for Open-Drain and Push-Pull Applications

1 Features

- Provides bidirectional voltage translation with no direction pin
- Supports up to 100-MHz up translation and greater than 100-MHz down translation at $\leq 30\text{pF}$ cap load and up to 40-MHz up/down translation at 50pF cap load
- Allows bidirectional voltage-level translation between
 - 0.95 V \leftrightarrow 1.8/2.5/3.3/5 V
 - 1.2 V \leftrightarrow 1.8/2.5/3.3/5 V
 - 1.8 V \leftrightarrow 2.5/3.3/5 V
 - 2.5 V \leftrightarrow 3.3/5 V
 - 3.3 V \leftrightarrow 5 V
- Low standby current
- 5-V tolerance I/O port to support TTL
- Low R_{ON} provides less signal distortion
- High-impedance I/O pins for EN = Low
- Flow-through pinout for easy PCB trace routing
- Latch-up performance $>100\text{ mA}$ per JESD 17
- -40°C to 125°C Operating temperature range

2 Applications

- GPIO, MDIO, PMBus, SMBus, SDIO, UART, I²C, and other interfaces in telecom infrastructure
- Enterprise Systems
- Communications Equipment
- Personal Electronics
- Industrial Applications

3 Description

The LSF family of devices supports bidirectional voltage translation without the need for DIR pin which minimizes system effort (for PMBus, I²C, SMBus, etc.). The LSF family of devices supports up to 100-MHz up translation and greater than 100-MHz down translation at $\leq 30\text{pF}$ cap load and up to 40-MHz up/down translation at 50pF cap load which allows the LSF family to support more consumer or telecom interfaces (MDIO or SDIO).

LSF family supports 5-V tolerance on I/O port which makes it compatible with TTL levels in industrial and telecom applications. The LSF family is able to set up different voltage translation levels on each channel which makes it very flexible.

Device Information⁽¹⁾

| PART NUMBER | PACKAGE(PINS) | BODY SIZE (NOM) |
|---------------------------|---------------|-------------------|
| LSF0101DRY | SON (6) | 1.45 mm x 1.00 mm |
| LSF0101DTQ ⁽²⁾ | X2SON (6) | 1.00 mm x 0.80 mm |
| LSF0102DQE | X2SON (8) | 1.40 mm x 1.00 mm |
| LSF0102YZT | DSBGA (8) | 1.90 mm x 1.00 mm |
| LSF0102DCT | SM8 (8) | 2.80 mm x 2.95 mm |
| LSF0102DCU | VSSOP (8) | 2.30 mm x 2.00 mm |
| LSF0108RKS | VQFN (20) | 4.50 mm x 2.50 mm |
| LSF0108PW | TSSOP (20) | 4.40 mm x 6.50 mm |

(1) For all available packages, see the orderable addendum at the end of the data sheet.

(2) Advance Information

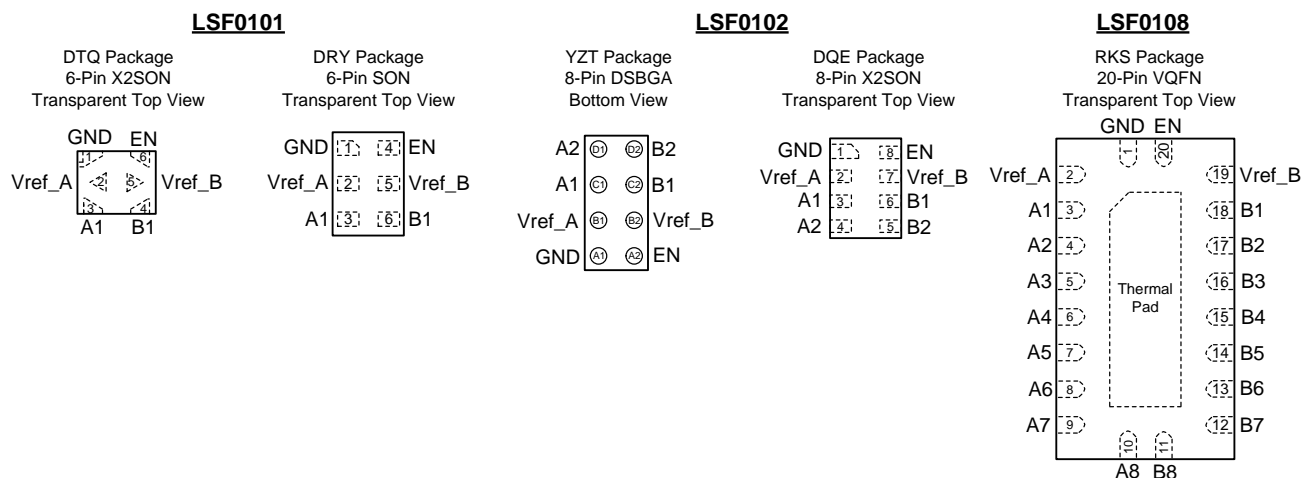

Table of Contents

| | | | |
|--|---|--|----|
| 1 Features | 1 | 6.14 LSF0108 AC Performance (Translating Up) Switching Characteristics, $V_{GATE} = 2.5\text{ V}$ | 8 |
| 2 Applications | 1 | 6.15 Typical Characteristics | 8 |
| 3 Description | 1 | 7 Parameter Measurement Information | 9 |
| 4 Revision History | 2 | 8 Detailed Description | 10 |
| 5 Pin Configuration and Functions | 4 | 8.1 Overview | 10 |
| 6 Specifications | 5 | 8.2 Functional Block Diagrams | 10 |
| 6.1 Absolute Maximum Ratings | 5 | 8.3 Feature Description | 11 |
| 6.2 ESD Ratings | 5 | 8.4 Device Functional Modes | 12 |
| 6.3 Recommended Operating Conditions | 5 | 9 Application and Implementation | 12 |
| 6.4 Thermal Information: LSF0101, LSF0108 | 6 | 9.1 Application Information | 12 |
| 6.5 Thermal Information: LSF0102 | 6 | 9.2 Typical Applications | 13 |
| 6.6 Electrical Characteristics | 6 | 10 Power Supply Recommendations | 16 |
| 6.7 LSF0101/02 AC Performance (Translating Down) Switching Characteristics, $V_{GATE} = 3.3\text{ V}$ | 7 | 11 Layout | 16 |
| 6.8 LSF0108 AC Performance (Translating Down) Switching Characteristics, $V_{GATE} = 3.3\text{ V}$ | 7 | 11.1 Layout Guidelines | 16 |
| 6.9 LSF0101/02 AC Performance (Translating Down) Switching Characteristics, $V_{GATE} = 2.5\text{ V}$ | 7 | 11.2 Layout Example | 16 |
| 6.10 LSF0108 AC Performance (Translating Down) Switching Characteristics, $V_{GATE} = 2.5\text{ V}$ | 7 | 12 Device and Documentation Support | 17 |
| 6.11 LSF0101/02 AC Performance (Translating Up) Switching Characteristics, $V_{GATE} = 3.3\text{ V}$ | 7 | 12.1 Related Links | 17 |
| 6.12 LSF0108 AC Performance (Translating Up) Switching Characteristics, $V_{GATE} = 3.3\text{ V}$ | 7 | 12.2 Community Resources | 17 |
| 6.13 LSF0101/02 AC Performance (Translating Up) Switching Characteristics, $V_{GATE} = 2.5\text{ V}$ | 8 | 12.3 Trademarks | 17 |
| | | 12.4 Electrostatic Discharge Caution | 17 |
| | | 12.5 Glossary | 17 |
| | | 13 Mechanical, Packaging, and Orderable Information | 17 |

4 Revision History

NOTE: Page numbers for previous revisions may differ from page numbers in the current version.

| Changes from Revision G (February 2016) to Revision H | Page |
|--|------|
| • Added Advance Information note to Device Information table for DTQ package | 1 |
| • Added DTQ6 pinout drawing to <i>Pin Configurations and Functions</i> section (Advance Information) | 4 |
| • Added Advance Information note to LSF0101 Thermal Information table. | 6 |
| • General improvements to Application and Implementation section for clarity. | 12 |

| Changes from Revision F (October 2015) to Revision G | Page |
|--|------|
| • Added all available package dimensions in Device Information and changed the pin diagram description. | 1 |

| Changes from Revision E (July 2015) to Revision F | Page |
|---|------|
| • Changed Features from "Supports High Speed Translation, Greater Than 100 MHz" to "Supports Up to 100 MHz Up Translation and Greater Than 100 MHz Down Translation at $\leq 30\text{pF}$ Cap Load and Up To 40 MHz Up/Down Translation at 50 pF Cap Load." | 1 |
| • Updated all propagation delay tables changed from generic to specific LSF devices. | 7 |

| Changes from Revision D (October 2014) to Revision E | Page |
|--|------|
| • Deleted "Less Than 1.5 ns Max Propagation Delay" from Features. | 1 |
| • Updated ESD Ratings table. | 5 |
| • Increased MAX value for T_A , Operating free-air temperature, from 85°C to 125°C. | 5 |

| Changes from Revision C (May 2014) to Revision D | Page |
|--|-------------|
| • Changed bidirectional voltage level translation from 1.0 to 0.95 | 1 |
| • Changed YZT package to fix view error. | 1 |
| • Changed YZT package to fix view error. | 4 |
| • Added pin numbers to <i>Pin Functions</i> table..... | 4 |
| • Added Vref_A footnote. | 13 |

| Changes from Revision B (May 2014) to Revision C | Page |
|---|-------------|
| • Changed LSF0108 status from preview to production. | 1 |
| • Updated document title. | 1 |
| • Updated Handling Ratings table. | 5 |

| Changes from Revision A (January 2014) to Revision B | Page |
|---|-------------|
| • Added LSF0108 to data sheet. | 1 |

| Changes from Original (December 2013) to Revision A | Page |
|--|-------------|
| • Updated part number..... | 1 |
| • Updated <i>Electrical Characteristics</i> table..... | 6 |

5 Pin Configuration and Functions

Pinout drawings are not to scale.

**LSF0101 DRY Package
6-Pin SON
Transparent Top View**

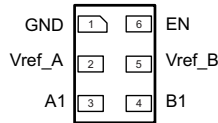

**LSF0101 DTQ Package - Advance Information
6-Pin X2SON
Transparent Top View**

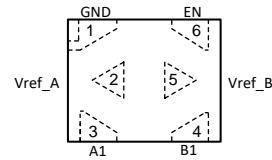

**LSF0102 DCT or DCU Package
8-Pin SM8 or VSSOP
Top View**

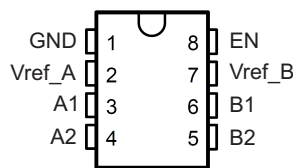

**LSF0102 DQE Package
8-Pin X2SON
Transparent Top View**

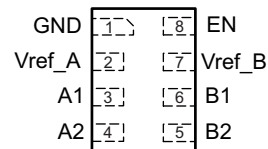

**LSF0102 YZT Package
8-Pin DSBGA
Bottom View**

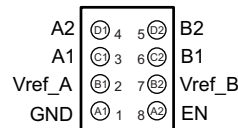

**LSF0108 PW Package
20-Pin TSSOP
Top View**

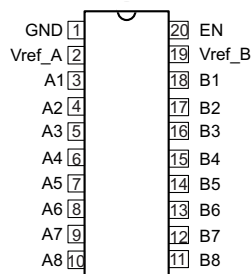

**LSF0108 RKS Package
20-Pin VQFN
Transparent Top View**

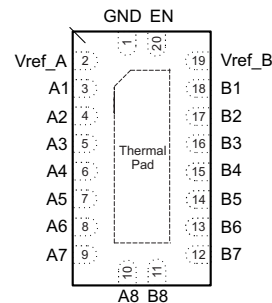

Pin Functions

| NAME | PIN | | | I/O | DESCRIPTION |
|--------|------------------------|--------------|---------------|-----|---|
| | DCT, DCU, DQE, YZT NO. | DRY, DTQ NO. | PW or RKS NO. | | |
| An | 3, 4 | 3 | 3 to 10 | I/O | Auto-Bidirectional Data port |
| Bn | 6, 5 | 4 | 18 to 11 | I/O | |
| EN | 8 | 6 | 20 | I | Enable input; connect to Vref_B and pull-up through a high resistor (200 kΩ). See Using the Enable Pin with the LSF Family |
| GND | 1 | 1 | 1 | — | Ground |
| Vref_A | 2 | 2 | 2 | — | Reference supply voltage. |
| Vref_B | 7 | 5 | 19 | — | For proper device biasing, see Application and Implementation and Understanding the Bias Circuit for the LSF Family . |

6 Specifications

6.1 Absolute Maximum Ratings⁽¹⁾

over operating free-air temperature (unless otherwise noted)

| | | MIN | MAX | UNIT |
|-----------|-------------------------------------|-----------|-----|------|
| V_I | Input voltage ⁽²⁾ | -0.5 | 7 | V |
| $V_{I/O}$ | Input/output voltage ⁽²⁾ | -0.5 | 7 | V |
| | Continuous channel current | | 128 | mA |
| I_{IK} | Input clamp current | $V_I < 0$ | -50 | mA |
| T_J | Junction Temperature | | 150 | °C |
| T_{stg} | Storage temperature range | -65 | 150 | °C |

- Stresses beyond those listed under "absolute maximum ratings" may cause permanent damage to the device. These are stress ratings only, and functional operation of the device at these or any other conditions beyond those indicated under "recommended operating conditions" is not implied. Exposure to absolute-maximum-rated conditions for extended periods may affect device reliability.
- The input and input/output negative-voltage ratings may be exceeded if the input and input/output clamp-current ratings are observed.

6.2 ESD Ratings

| | | VALUE | UNIT |
|-------------|-------------------------|--|-------|
| $V_{(ESD)}$ | Electrostatic discharge | Human-body model (HBM), per ANSI/ESDA/JEDEC JS-001 ⁽¹⁾ | ±2000 |
| | | Charged-device model (CDM), per JEDEC specification JESD22-C101 ⁽²⁾ | ±1000 |

- JEDEC document JEP155 states that 500-V HBM allows safe manufacturing with a standard ESD control process. Manufacturing with less than 500-V HBM is possible with the necessary precautions.
- JEDEC document JEP157 states that 250-V CDM allows safe manufacturing with a standard ESD control process. Manufacturing with less than 250-V CDM is possible with the necessary precautions.

6.3 Recommended Operating Conditions

over operating free-air temperature range (unless otherwise noted)

| | | MIN | MAX | UNIT |
|-------------------|--------------------------------|-----|-----|------|
| $V_{I/O}$ | Input/output voltage | 0 | 5 | V |
| $V_{ref_A/B/EN}$ | Reference voltage | 0 | 5 | V |
| I_{PASS} | Pass transistor current | | 64 | mA |
| T_A | Operating free-air temperature | -40 | 125 | °C |

6.4 Thermal Information: LSF0101, LSF0108

| THERMAL METRIC ⁽¹⁾ | LSF0101 | | LSF0108 | | UNIT |
|--|----------------------------|-----------|------------|------------|------|
| | DTQ (X2SON) ⁽²⁾ | DRY (SON) | RKS (VQFN) | PW (TSSOP) | |
| | 6 PINS | 6 PINS | 20 PINS | 20 PINS | |
| R _{θJA} Junction-to-ambient thermal resistance | 294.4 | 407.0 | 49.3 | 106.6 | °C/W |
| R _{θJC(top)} Junction-to-case (top) thermal resistance | 188.9 | 285.2 | 45.9 | 41.0 | °C/W |
| R _{θJB} Junction-to-board thermal resistance | 216.8 | 271.6 | 20.6 | 57.6 | °C/W |
| ψ _{JT} Junction-to-top characterization parameter | 26.5 | 113.5 | 2.5 | 4.2 | °C/W |
| ψ _{JB} Junction-to-board characterization parameter | 216.0 | 271.0 | 20.6 | 47.0 | °C/W |
| R _{θJC(bot)} Junction-to-case (bottom) thermal resistance | n/a | n/a | 3.4 | n/a | °C/W |

(1) For more information about traditional and new thermal metrics, see the *IC Package Thermal Metrics* application report, [SPRA953](#).

(2) Advance Information

6.5 Thermal Information: LSF0102

| THERMAL METRIC ⁽¹⁾ | LSF0102 | | | | UNIT |
|--|-----------|-----------|-------------|-------------|------|
| | DCU (US8) | DCT (SM8) | DQE (X2SON) | YZT (DSBGA) | |
| | 8 PINS | 8 PINS | 8 PINS | 8 PINS | |
| R _{θJA} Junction-to-ambient thermal resistance | 210.1 | 189.6 | 246.5 | 125.5 | °C/W |
| R _{θJC(top)} Junction-to-case (top) thermal resistance | 89.1 | 119.6 | 149.1 | 1.0 | °C/W |
| R _{θJB} Junction-to-board thermal resistance | 88.8 | 102.1 | 100.0 | 62.7 | °C/W |
| ψ _{JT} Junction-to-top characterization parameter | 8.3 | 44.5 | 17.1 | 3.4 | °C/W |
| ψ _{JB} Junction-to-board characterization parameter | 88.4 | 101.0 | 99.8 | 62.7 | °C/W |
| R _{θJC(bot)} Junction-to-case (bottom) thermal resistance | n/a | n/a | n/a | n/a | °C/W |

(1) For more information about traditional and new thermal metrics, see the *IC Package Thermal Metrics* application report, [SPRA953](#).

6.6 Electrical Characteristics

over recommended operating free-air temperature range (unless otherwise noted)

| PARAMETER | TEST CONDITIONS | | MIN | TYP ⁽¹⁾ | MAX | UNIT |
|--------------------------------|--|--|--|--------------------|------|------|
| V _{IK} | I _I = -18 mA, | V _{EN} = 0 | | | -1.2 | V |
| I _{IH} | V _I = 5 V | V _{EN} = 0 | | | 5.0 | μA |
| I _{CC} | V _{ref_B} = V _{EN} = 5.5 V, V _{ref_A} = 4.5 V or 1 V, I _O = 0, V _I = V _{CC} or GND | | | 1 | | μA |
| C _{I(ref_A/B/EN)} | V _I = 3 V or 0 | | | 11 | | pF |
| C _{io(off)} | V _O = 3 V or 0, | V _{EN} = 0 | | 4.0 | 6.0 | pF |
| C _{io(on)} | V _O = 3 V or 0, | V _{EN} = 3 V | | 10.5 | 12.5 | pF |
| r _{on} ⁽²⁾ | V _I = 0, | I _O = 64 mA | V _{ref_A} = 3.3 V; V _{ref_B} = V _{EN} = 5 V | | 8.0 | Ω |
| | | | V _{ref_A} = 1.8 V; V _{ref_B} = V _{EN} = 5 V | | 9.0 | |
| | | | V _{ref_A} = 1.0 V; V _{ref_B} = V _{EN} = 5 V | | 10 | |
| | V _I = 0, | I _O = 32 mA | V _{ref_A} = 1.8 V; V _{ref_B} = V _{EN} = 5 V | | 10 | Ω |
| | | | V _{ref_A} = 2.5 V; V _{ref_B} = V _{EN} = 5 V | | 15 | |
| | V _I = 1.8 V, | I _O = 15 mA | V _{ref_A} = 3.3 V; V _{ref_B} = V _{EN} = 5 V | | 9.0 | Ω |
| | V _I = 1.0 V, | I _O = 10 mA | V _{ref_A} = 1.8 V; V _{ref_B} = V _{EN} = 3.3 V | | 18 | Ω |
| | V _I = 0 V, | I _O = 10 mA | V _{ref_A} = 1.0 V; V _{ref_B} = V _{EN} = 3.3 V | | 20 | Ω |
| V _I = 0 V, | I _O = 10 mA | V _{ref_A} = 1.0 V; V _{ref_B} = V _{EN} = 1.8 V | | 30 | Ω | |

(1) All typical values are at T_A = 25°C.

(2) Measured by the voltage drop between the A and B pins at the indicated current through the switch. On-state resistance is determined by the lowest voltage of the two (A or B) pins.

6.7 LSF0101/02 AC Performance (Translating Down) Switching Characteristics, $V_{GATE} = 3.3\text{ V}$

over recommended operating free-air temperature range, $V_{GATE} = 3.3\text{ V}$, $V_{IH} = 3.3\text{ V}$, $V_{IL} = 0$, and $V_M = 1.15\text{ V}$ (unless otherwise noted) (see [Figure 2](#))

| PARAMETER | FROM (INPUT) | TO (OUTPUT) | $C_L = 50\text{ pF}$ | | $C_L = 30\text{ pF}$ | | $C_L = 15\text{ pF}$ | | UNIT |
|-----------|--------------|-------------|----------------------|-----|----------------------|-----|----------------------|-----|------|
| | | | TYP | MAX | TYP | MAX | TYP | MAX | |
| t_{PLH} | A or B | B or A | 1.1 | | 0.7 | | 0.3 | | ns |
| t_{PHL} | | | 1.2 | | 0.8 | | 0.4 | | |

6.8 LSF0108 AC Performance (Translating Down) Switching Characteristics, $V_{GATE} = 3.3\text{ V}$

over recommended operating free-air temperature range, $V_{GATE} = 3.3\text{ V}$, $V_{IH} = 3.3\text{ V}$, $V_{IL} = 0$, and $V_M = 1.15\text{ V}$ (unless otherwise noted) (see [Figure 2](#))

| PARAMETER | FROM (INPUT) | TO (OUTPUT) | $C_L = 50\text{ pF}$ | | $C_L = 30\text{ pF}$ | | $C_L = 15\text{ pF}$ | | UNIT |
|-----------|--------------|-------------|----------------------|-----|----------------------|-----|----------------------|-----|------|
| | | | TYP | MAX | TYP | MAX | TYP | MAX | |
| t_{PLH} | A or B | B or A | 1.9 | | 1.4 | | 0.75 | | ns |
| t_{PHL} | | | 2 | | 1.5 | | 0.85 | | |

6.9 LSF0101/02 AC Performance (Translating Down) Switching Characteristics, $V_{GATE} = 2.5\text{ V}$

over recommended operating free-air temperature range, $V_{GATE} = 2.5\text{ V}$, $V_{IH} = 2.5\text{ V}$, $V_{IL} = 0$, and $V_M = 0.75\text{ V}$ (unless otherwise noted) (see [Figure 2](#))

| PARAMETER | FROM (INPUT) | TO (OUTPUT) | $C_L = 50\text{ pF}$ | | $C_L = 30\text{ pF}$ | | $C_L = 15\text{ pF}$ | | UNIT |
|-----------|--------------|-------------|----------------------|-----|----------------------|-----|----------------------|-----|------|
| | | | TYP | MAX | TYP | MAX | TYP | MAX | |
| t_{PLH} | A or B | B or A | 1.2 | | 0.8 | | 0.35 | | ns |
| t_{PHL} | | | 1.3 | | 1 | | 0.5 | | |

6.10 LSF0108 AC Performance (Translating Down) Switching Characteristics, $V_{GATE} = 2.5\text{ V}$

over recommended operating free-air temperature range, $V_{GATE} = 2.5\text{ V}$, $V_{IH} = 2.5\text{ V}$, $V_{IL} = 0$, and $V_M = 0.75\text{ V}$ (unless otherwise noted) (see [Figure 2](#))

| PARAMETER | FROM (INPUT) | TO (OUTPUT) | $C_L = 50\text{ pF}$ | | $C_L = 30\text{ pF}$ | | $C_L = 15\text{ pF}$ | | UNIT |
|-----------|--------------|-------------|----------------------|-----|----------------------|-----|----------------------|-----|------|
| | | | TYP | MAX | TYP | MAX | TYP | MAX | |
| t_{PLH} | A or B | B or A | 2 | | 1.45 | | 0.8 | | ns |
| t_{PHL} | | | 2.1 | | 1.55 | | 0.9 | | |

6.11 LSF0101/02 AC Performance (Translating Up) Switching Characteristics, $V_{GATE} = 3.3\text{ V}$

over recommended operating free-air temperature range, $V_{GATE} = 3.3\text{ V}$, $V_{IH} = 2.3\text{ V}$, $V_{IL} = 0$, $V_T = 3.3\text{ V}$, $V_M = 1.15\text{ V}$ and $R_L = 300$ (unless otherwise noted) (see [Figure 2](#))

| PARAMETER | FROM (INPUT) | TO (OUTPUT) | $C_L = 50\text{ pF}$ | | $C_L = 30\text{ pF}$ | | $C_L = 15\text{ pF}$ | | UNIT |
|-----------|--------------|-------------|----------------------|-----|----------------------|-----|----------------------|-----|------|
| | | | TYP | MAX | TYP | MAX | TYP | MAX | |
| t_{PLH} | A or B | B or A | 1 | | 0.8 | | 0.4 | | ns |
| t_{PHL} | | | 1 | | 0.9 | | 0.4 | | |

6.12 LSF0108 AC Performance (Translating Up) Switching Characteristics, $V_{GATE} = 3.3\text{ V}$

over recommended operating free-air temperature range, $V_{GATE} = 3.3\text{ V}$, $V_{IH} = 2.3\text{ V}$, $V_{IL} = 0$, $V_T = 3.3\text{ V}$, $V_M = 1.15\text{ V}$ and $R_L = 300$ (unless otherwise noted) (see [Figure 2](#))

| PARAMETER | FROM (INPUT) | TO (OUTPUT) | $C_L = 50\text{ pF}$ | | $C_L = 30\text{ pF}$ | | $C_L = 15\text{ pF}$ | | UNIT |
|-----------|--------------|-------------|----------------------|-----|----------------------|-----|----------------------|-----|------|
| | | | TYP | MAX | TYP | MAX | TYP | MAX | |
| t_{PLH} | A or B | B or A | 2.1 | | 1.55 | | 0.9 | | ns |
| t_{PHL} | | | 2.2 | | 1.65 | | 1 | | |

6.13 LSF0101/02 AC Performance (Translating Up) Switching Characteristics, $V_{GATE} = 2.5\text{ V}$

over recommended operating free-air temperature range, $V_{GATE} = 2.5\text{ V}$, $V_{IH} = 1.5\text{ V}$, $V_{IL} = 0$, $V_T = 2.5\text{ V}$, $V_M = 0.75\text{ V}$ and $R_L = 300$ (unless otherwise noted) (see Figure 2)

| PARAMETER | FROM (INPUT) | TO (OUTPUT) | $C_L = 50\text{ pF}$ | | $C_L = 30\text{ pF}$ | | $C_L = 15\text{ pF}$ | | UNIT |
|-----------|--------------|-------------|----------------------|-----|----------------------|-----|----------------------|-----|------|
| | | | TYP | MAX | TYP | MAX | TYP | MAX | |
| t_{PLH} | A or B | B or A | 1.1 | | 0.9 | | 0.45 | | ns |
| t_{PHL} | | | 1.3 | | 1.1 | | 0.6 | | |

6.14 LSF0108 AC Performance (Translating Up) Switching Characteristics, $V_{GATE} = 2.5\text{ V}$

over recommended operating free-air temperature range, $V_{GATE} = 2.5\text{ V}$, $V_{IH} = 1.5\text{ V}$, $V_{IL} = 0$, $V_T = 2.5\text{ V}$, $V_M = 0.75\text{ V}$ and $R_L = 300$ (unless otherwise noted) (see Figure 2)

| PARAMETER | FROM (INPUT) | TO (OUTPUT) | $C_L = 50\text{ pF}$ | | $C_L = 30\text{ pF}$ | | $C_L = 15\text{ pF}$ | | UNIT |
|-----------|--------------|-------------|----------------------|-----|----------------------|-----|----------------------|-----|------|
| | | | TYP | MAX | TYP | MAX | TYP | MAX | |
| t_{PLH} | A or B | B or A | 1.8 | | 1.35 | | 0.8 | | ns |
| t_{PHL} | | | 1.9 | | 1.45 | | 0.9 | | |

6.15 Typical Characteristics

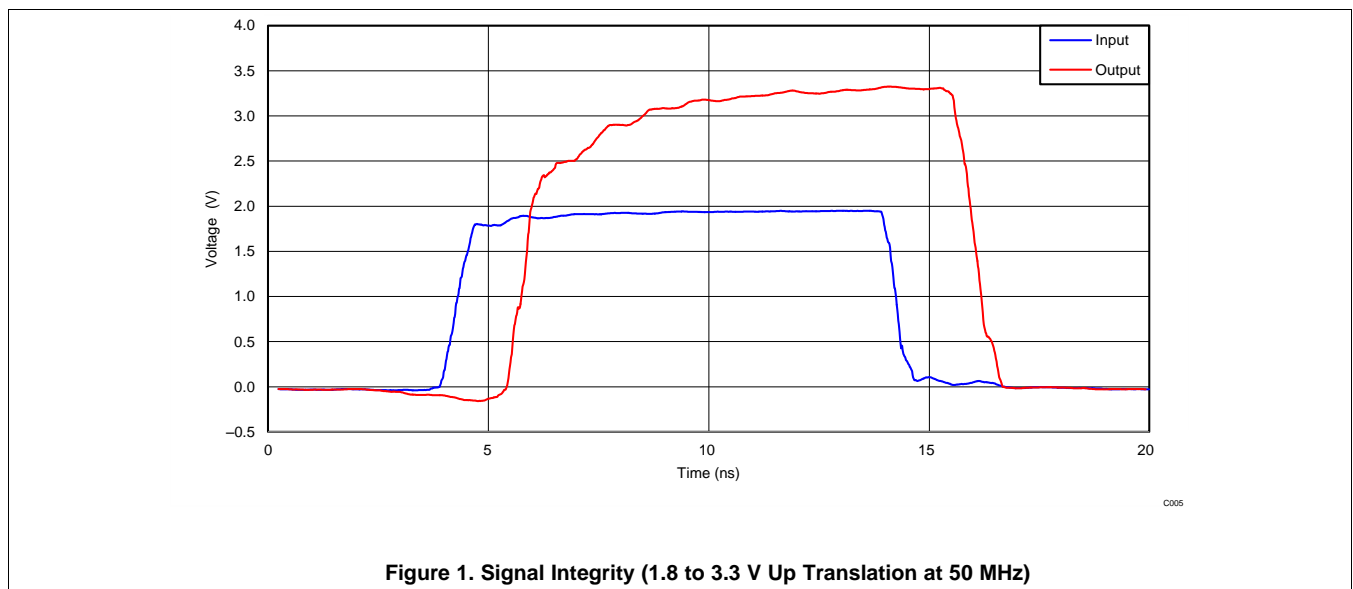

7 Parameter Measurement Information

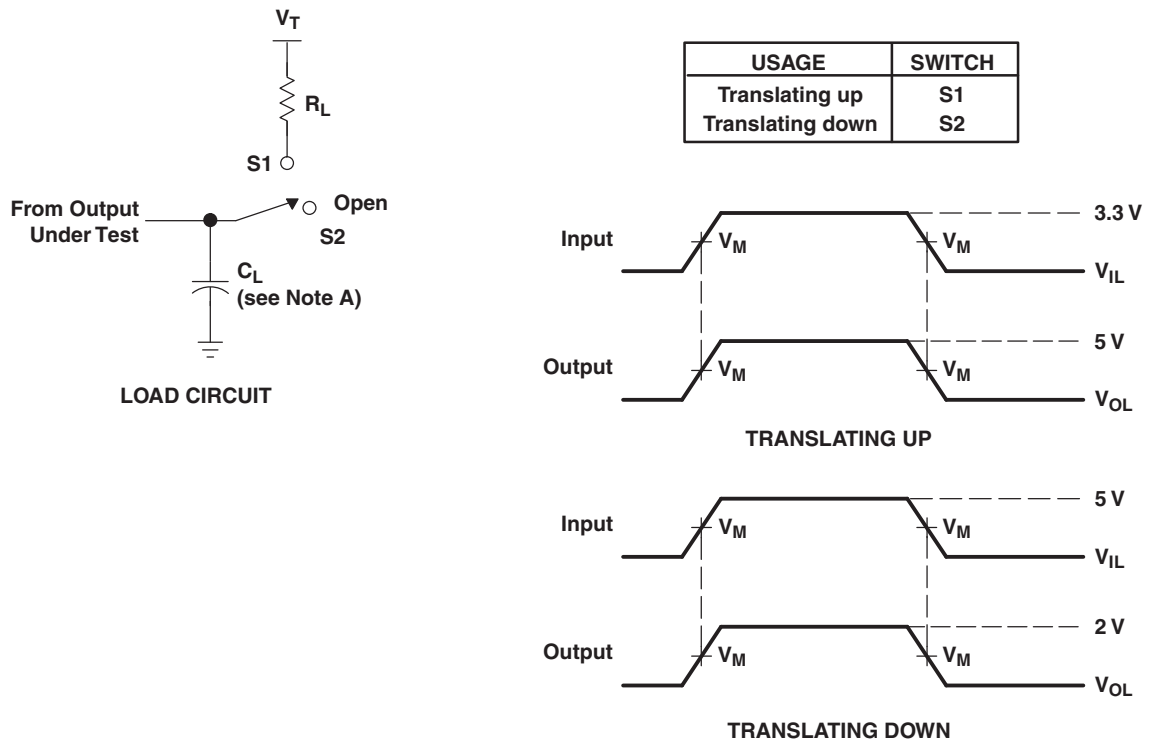

- NOTES: A. C_L includes probe and jig capacitance.
 B. All input pulses are supplied by generators having the following characteristics: PRR \leq 10 MHz, $Z_O = 50 \Omega$, $t_r \leq 2$ ns, $t_f \leq 2$ ns.
 C. The outputs are measured one at a time, with one transition per measurement.

Figure 2. Load Circuit for Outputs

8 Detailed Description

8.1 Overview

The LSF family can be used in level-translation applications for interfacing devices or systems operating with one another, that operate at different interface voltages. The LSF family is ideal for use in applications where an open-drain driver is connected to the data I/Os. With appropriate pull-up resistors and layout, LSF can achieve 100 MHz. The LSF family can also be used in applications where a push-pull driver is connected to the data I/Os. For an overview of device setup and operation, see [The Logic Minute](#) training series on [Understanding the LSF Family of Bidirectional, Multi-Voltage Level Translators](#).

8.2 Functional Block Diagrams

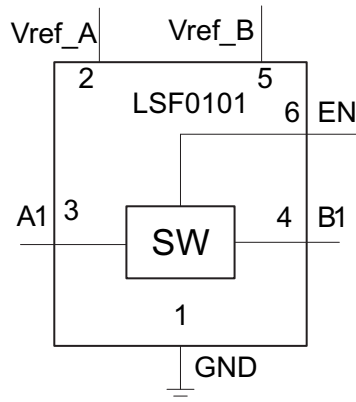

Figure 3. LSF0101 Functional Block Diagram

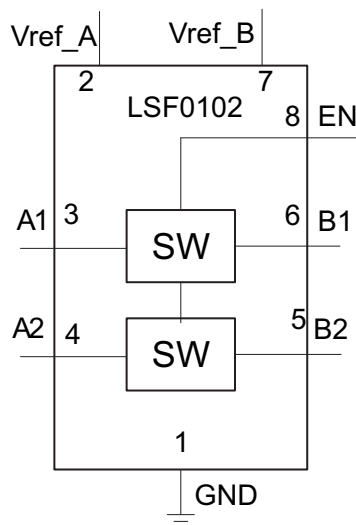

Figure 4. LSF0102 Functional Block Diagram

Functional Block Diagrams (continued)

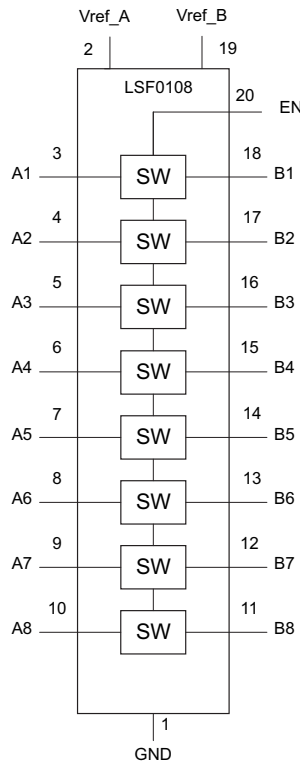

Figure 5. LSF0108 Functional Block Diagram

8.3 Feature Description

8.3.1 Auto Bidirectional Voltage Translation

All devices in the LSF family are auto bidirectional voltage level translators that are operational from 0.95 V on the Vref_A supply and from 1.8 to 5.5 V on the Vref_B supply. This allows bidirectional voltage translation between 0.95 V and 5.5 V without the need for a direction pin in open-drain or push-pull applications. LSF family supports level translation applications with transmission speeds greater than 100 Mbps for open-drain systems using a 30-pF capacitance and 250-Ω pullup resistor. For additional details on the recommended setup and operation of the LSF family of devices, see the [Understanding the LSF Family of Bidirectional, Multi-Voltage Level Translators](#) training series.

8.3.2 Output Enable

To enable the I/O pins, the EN input should be tied directly to Vref_B during operation. To ensure the high impedance state during power-up, power-down, or during operation, the EN pin must be LOW. The EN pin should always be tied directly to the Vref_B pin and is recommended to be disabled by an open-drain driver without a pullup resistor. For additional details on how to use the enable pin, see the [Using the Enable Pin with the LSF Family](#) video.

Table 1. Enable Pin Function Table

| INPUT EN ⁽¹⁾ PIN | Data Port State |
|-----------------------------|-----------------|
| Tied directly to Vref_B | An = Bn |
| L | Hi-Z |

(1) EN is controlled by V_{ref_B} logic levels.

8.4 Device Functional Modes

For each channel (n), when either the An or Bn port is LOW, the switch provides a low impedance path between the An and Bn ports; the corresponding Bn or An port will be pulled LOW. The low R_{ON} of the switch allows connections to be made with minimal propagation delay and signal distortion.

When the signal is being driven from Bn to An and the Bn port is driven HIGH, the switch will be OFF, clamping the voltage on the An port to the voltage set by Vref_A. When the signal is being driven from A to B and the An port is HIGH, the switch will be OFF and the Bn port will then driven to a voltage higher than Vref_A by the pullup resistor that is connected to the pull-up supply voltage (V_{pu#}). This functionality allows seamless translation between higher and lower voltages selected by the user, without the need for directional control.

Refer to [Table 1](#) for a summary of device operation. For additional details on the functional operation of the LSF family of devices, see the [Down Translation with the LSF Family](#) and [Up Translation with the LSF Family](#) videos.

Table 2. Device Functionality

| Signal Direction ⁽¹⁾ | Input State | Switch State | Functionality |
|---------------------------------|-------------|-------------------------|---|
| B to A (Down Translation) | B = LOW | ON (Low Impedance) | A-side voltage is pulled low through the switch to the B-side voltage |
| | B = HIGH | OFF (High Impedance) | A-side voltage is clamped at Vref_A ⁽²⁾ |
| A to B (Up Translation) | A = LOW | ON (Low Impedance) | B-side voltage is pulled low through the switch to the A-side voltage |
| | A = HIGH | OFF (High Impedance) | B-side voltage is clamped at Vref_A and then pulled up to the Vpu# supply voltage |

- (1) The downstream channel should not be actively driven through a low impedance driver, or else there may be bus contention.
 (2) The A-side can have a pullup to Vref_A for additional current drive capability or may also be pulled above Vref_A with a pullup resistor. Specifications in the [Recommended Operating Conditions](#) should always be followed.

9 Application and Implementation

NOTE

Information in the following applications sections is not part of the TI component specification, and TI does not warrant its accuracy or completeness. TI's customers are responsible for determining suitability of components for their purposes. Customers should validate and test their design implementation to confirm system functionality.

9.1 Application Information

The LSF devices are able to perform voltage translation for open-drain or push-pull interfaces. [Table 3](#) provides common interfaces and the corresponding device recommendation from the LSF family which supports the corresponding bit count.

Table 3. Voltage Translator for Common Interfaces

| Part Name | Channel Number | Interface |
|-----------|----------------|---|
| LSF0101 | 1 | GPIO |
| LSF0102 | 2 | GPIO, MDIO, SMBus, PMBus, I ² C |
| LSF0108 | 8 | GPIO, MDIO, SDIO, SVID, UART, SMBus, PMBus, I ² C, SPI |

9.2 Typical Applications

9.2.1 Open-Drain Interface (I²C, PMBus, SMBus, GPIO)

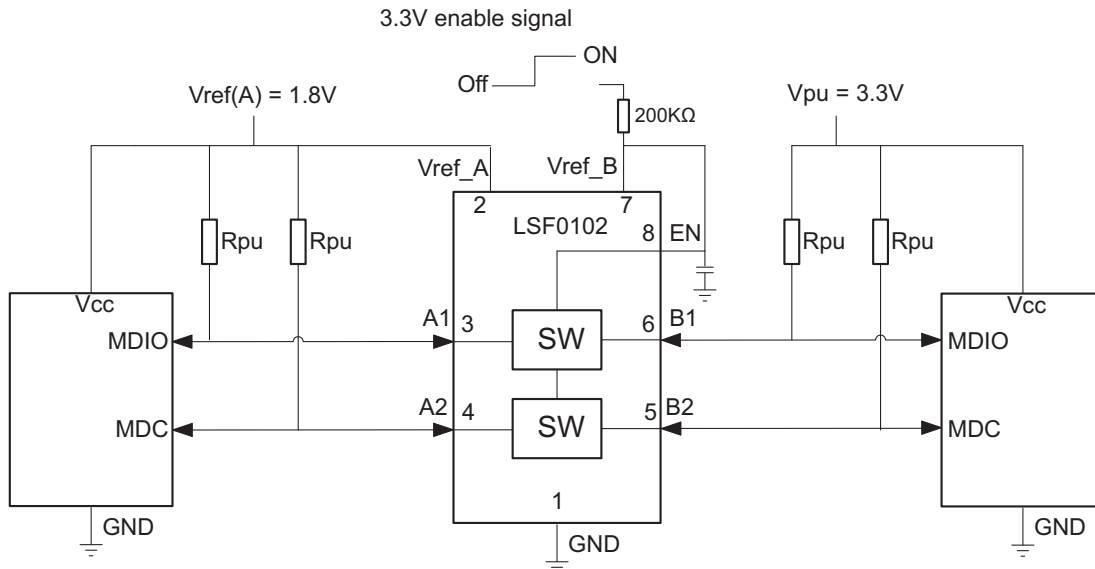

Figure 6. Typical Application Circuit for Open-Drain Translation (MDIO shown as an example)

9.2.1.1 Design Requirements

9.2.1.1.1 Enable, Disable, and Reference Voltage Guidelines

The LSF family has an EN input that is used to disable the device by setting EN LOW, placing all I/Os in the high-impedance state. Since the LSF family of devices are switch-type voltage translators, the power consumption is very low. TI recommends always enabling the LSF family for bidirectional applications (I²C, SMBus, PMBus, or MDIO).

Table 4. Application Operating Condition

| PARAMETER | MIN | TYP | MAX | UNIT |
|-----------------------|-------------------------|--------------|--------|------|
| Vref_A ⁽¹⁾ | reference voltage (A) | 0.95 | 4.5 | V |
| Vref_B | reference voltage (B) | Vref_A + 0.8 | 5.5 | V |
| V _{I(EN)} | input voltage on EN pin | Vref_A + 0.8 | 5.5 | V |
| Vpu | pull-up supply voltage | 0 | Vref_B | V |

(1) Vref_A is required to be the lowest voltage level across all inputs and outputs.

The 200 kΩ, pull-up resistor is required to allow Vref_B to regulate the EN input and properly bias the device for translation. For additional details on device biasing, see the [Understanding the Bias Circuit for the LSF Family](#) video. A filter capacitor on Vref_B is recommended. Also Vref_B and V_{I(EN)} are recommended to be 1.0 V higher than Vref_A for best signal integrity.

9.2.1.2 Detailed Design Procedure

9.2.1.2.1 Bidirectional Translation

For the bidirectional translation configuration (higher voltage to lower voltage or lower voltage to higher voltage), the EN input must be connected to Vref_B and both pins must be pulled up to the HIGH side Vpu through a pull-up resistor (typically 200 kΩ). This allows Vref_B to regulate the EN input and bias the channels for proper translation. A filter capacitor on Vref_B is recommended for a stable supply at the device. The master output driver can be push-pull or open-drain (pull-up resistors may be required) and the slave device output can be push-pull or open-drain (pull-up resistors are required to pull the Bn outputs to Vpu).

If either output is push-pull, data must be unidirectional or the outputs must be tri-state and be controlled by some direction-control mechanism to prevent HIGH-to-LOW bus contention in either direction. If both outputs are open-drain, no direction control is needed.

When Vref_B is connected through a 200-kΩ resistor to a 3.3-V Vpu power supply and Vref_A is set 1.8 V, as shown in Figure 6, the A1 and A2 channels have a maximum output voltage equal to Vref_A, and the B1 and B2 channels have a maximum output voltage equal to Vpu.

9.2.1.2.2 Pull-up Resistor Sizing

The pull-up resistor value needs to limit the current through the pass transistor when it is in the ON state to about 15 mA. This ensures a voltage drop of 260 mV to 350 mV to have a valid LOW signal on the downstream channel. If the current through the pass transistor is higher than 15 mA, the voltage drop is also higher in the ON state. To set the current through each pass transistor at 15 mA, calculate the pull-up resistor value using the following equation:

$$R_{pu} = (V_{pu} - 0.35 \text{ V}) / 0.015 \text{ A} \quad (1)$$

Table 5 summarizes resistor values, reference voltages, and currents at 15 mA, 10 mA, and 3 mA. The resistor value shown in the +10% column (or a larger value) should be used to ensure that the voltage drop across the transistor is 350 mV or less. The external driver must be able to sink the total current from the resistors on both sides of the LSF family device at 0.175 V, although the 15 mA applies only to current flowing through the LSF family device.

Table 5. Pull-up Resistor Values⁽¹⁾⁽²⁾

| V _{DPU} | 15 mA | | 10 mA | | 3 mA | |
|------------------|-------------|-------------------------|-------------|-------------------------|-------------|-------------------------|
| | NOMINAL (Ω) | +10% ⁽³⁾ (Ω) | NOMINAL (Ω) | +10% ⁽³⁾ (Ω) | NOMINAL (Ω) | +10% ⁽³⁾ (Ω) |
| 5 V | 310 | 341 | 465 | 512 | 1550 | 1705 |
| 3.3 V | 197 | 217 | 295 | 325 | 983 | 1082 |
| 2.5 V | 143 | 158 | 215 | 237 | 717 | 788 |
| 1.8 V | 97 | 106 | 145 | 160 | 483 | 532 |
| 1.5 V | 77 | 85 | 115 | 127 | 383 | 422 |
| 1.2 V | 57 | 63 | 85 | 94 | 283 | 312 |

(1) Calculated for V_{OL} = 0.35 V

(2) Assumes output driver V_{OL} = 0.175 V at stated current

(3) +10% to compensate for V_{DD} range and resistor tolerance

9.2.1.3 Application Curve

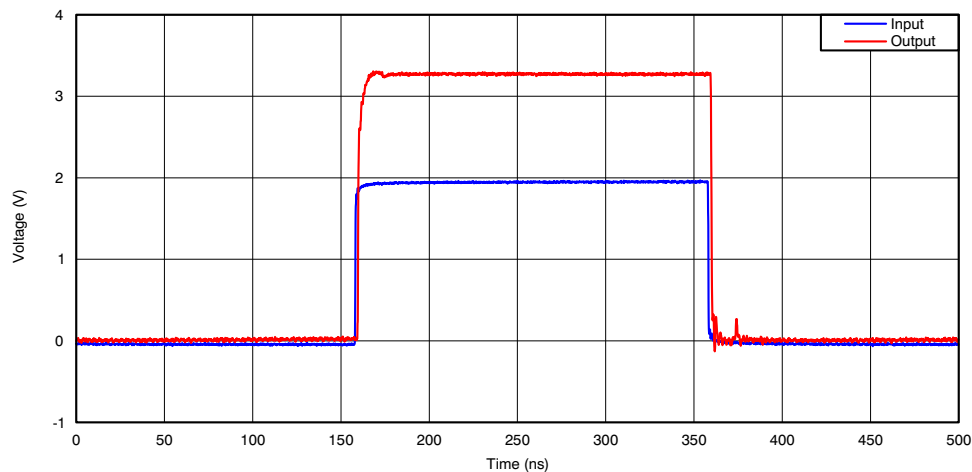

Figure 7. Open Drain Translation (1.8 V to 3.3 V at 2.5 MHz)

9.2.2 Mixed-Mode Voltage Translation

The supply voltage ($V_{pu\#}$) for each channel can be individually set with a pull-up resistor. An example of this mixed-mode multi-voltage translation is shown in Figure 8. For additional details on multi-voltage translation, see the *Multi-voltage Translation with the LSF Family* video.

With the Vref_B pulled up to 5V and Vref_A connected to 1.8V, all channels will be clamped to 1.8V at which point a pullup can be used to define the high level voltage for a given channel.

- **Push-Pull Down Translation (5V to 1.8V):** Channel 1 is an example of this setup. When B1 is 5V, A1 is clamped to 1.8V, and when B1 is LOW, A1 is driven LOW through the switch.
- **Push-Pull Up Translation (1.8V to 5V):** Channel 2 is an example of this setup. When A2 is 1.8V, the switch is high impedance and the B2 channel is pulled up to 5V. When A2 is LOW, B2 is driven LOW through the switch.
- **Push-Pull Down Translation (3.3V to 1.8V):** Channels 3 and 4 are examples of this setup. When either B3 or B4 are driven to 3.3V, A3 or A4 are clamped to 1.8V, and when either B3 or B4 are LOW, A3 or A4 are driven LOW through the switch.
- **Open-Drain Bidirectional Translation (3.3V ↔ 1.8V):** Channels 5 through 8 are examples of this setup. These channels are for bidirectional operation for I²C and MDIO to translate between 1.8V and 3.3V with open-drain drivers.

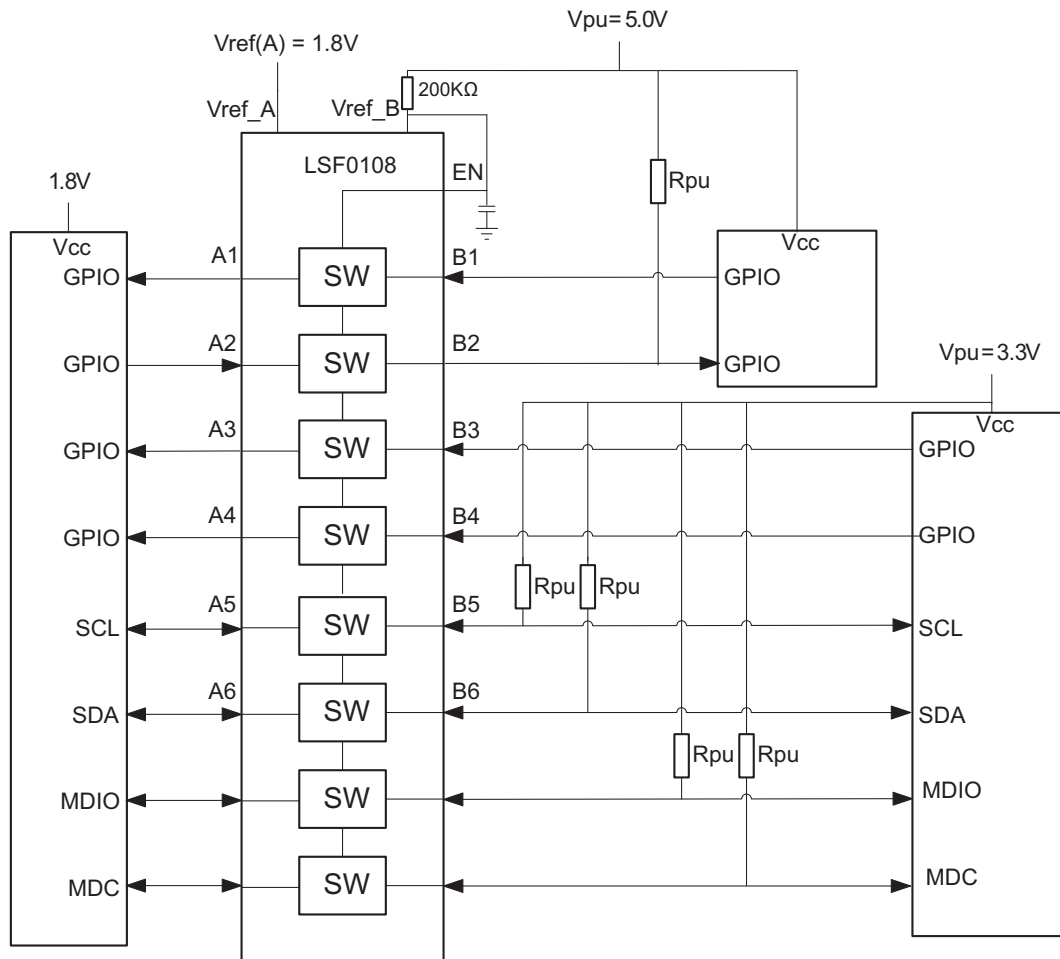

Figure 8. Multi-Voltage Translation with the LSF0108

10 Power Supply Recommendations

There are no power sequence requirements for the LSF family. For recommended operating voltages for all supply and input pins, see [Table 6](#).

Table 6. Recommended Operating Voltages

| PARAMETER | MIN | TYP | MAX | UNIT |
|---|--------------|-----|--------|------|
| Vref_A ⁽¹⁾ reference voltage (A) | 0.95 | | 4.5 | V |
| Vref_B reference voltage (B) | Vref_A + 0.8 | | 5.5 | V |
| V _{I(EN)} input voltage on EN pin | Vref_A + 0.8 | | 5.5 | V |
| V _{pu} pull-up supply voltage | 0 | | Vref_B | V |

(1) Vref_A is required to be the lowest voltage level across all inputs and outputs.

11 Layout

11.1 Layout Guidelines

Because the LSF family is a switch-type level translator, the signal integrity is highly related with a pull-up resistor and PCB capacitance condition.

- Short signal trace as possible to reduce capacitance and minimize stub from pull-up resistor.
- Place LSF close to high voltage side.
- Select the appropriate pull-up resistor that applies to translation levels and driving capability of transmitter.

11.2 Layout Example

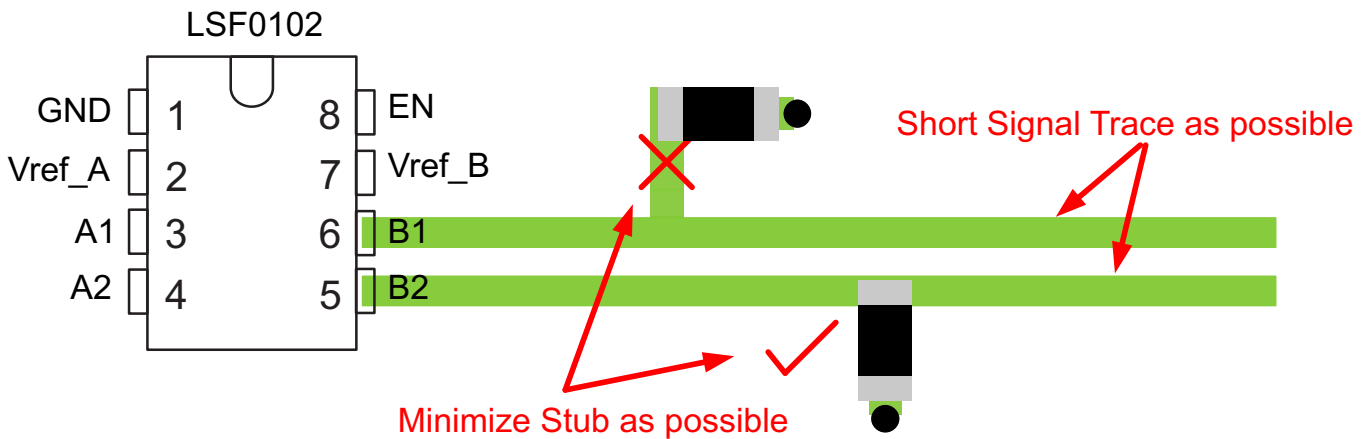

Figure 9. Short Trace Layout

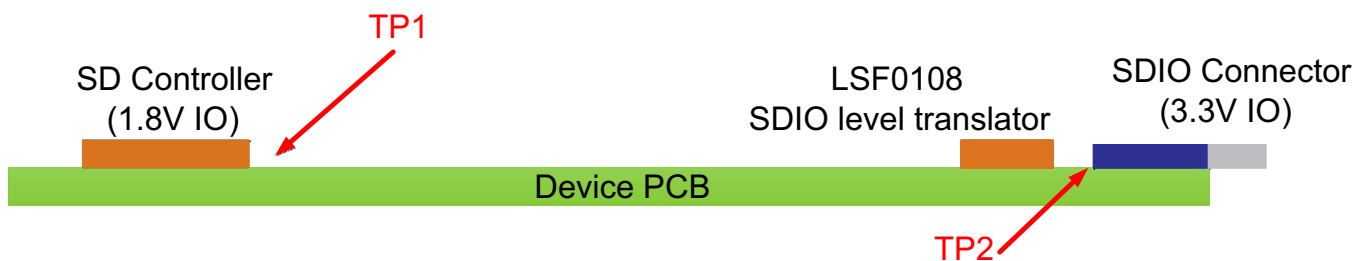

Figure 10. Device Placement

12 Device and Documentation Support

12.1 Related Links

The table below lists quick access links. Categories include technical documents, support and community resources, tools and software, and quick access to sample or buy.

Table 7. Related Links

| PARTS | PRODUCT FOLDER | SAMPLE & BUY | TECHNICAL DOCUMENTS | TOOLS & SOFTWARE | SUPPORT & COMMUNITY |
|---------|----------------------------|----------------------------|----------------------------|----------------------------|----------------------------|
| LSF0101 | Click here | Click here | Click here | Click here | Click here |
| LSF0102 | Click here | Click here | Click here | Click here | Click here |
| LSF0108 | Click here | Click here | Click here | Click here | Click here |

1. [LSF Translator Family Evaluation Module](#)
2. The Logic Minute Video Training Series on Understanding the LSF Family of Devices
 - [Introduction - Voltage Level Translation with the LSF Family](#)
 - [Understanding the Bias Circuit for the LSF Family](#)
 - [Using the Enable Pin with the LSF Family](#)
 - [Translation Basics with the LSF Family](#)
 - [Down Translation with the LSF Family](#)
 - [Up Translation with the LSF Family](#)
 - [Multi-Voltage Translation with the LSF Family](#)
 - [Single Supply Translation with the LSF Family](#)
3. [Voltage Level Translation with the LSF Family](#) Application Note
4. [Biasing Requirements for TXS, TXB, and LSF Auto-Bidirectional Translators](#) Application Note

12.2 Community Resources

The following links connect to TI community resources. Linked contents are provided "AS IS" by the respective contributors. They do not constitute TI specifications and do not necessarily reflect TI's views; see TI's [Terms of Use](#).

TI E2E™ Online Community *TI's Engineer-to-Engineer (E2E) Community*. Created to foster collaboration among engineers. At e2e.ti.com, you can ask questions, share knowledge, explore ideas and help solve problems with fellow engineers.

Design Support *TI's Design Support* Quickly find helpful E2E forums along with design support tools and contact information for technical support.

12.3 Trademarks

E2E is a trademark of Texas Instruments.

12.4 Electrostatic Discharge Caution



These devices have limited built-in ESD protection. The leads should be shorted together or the device placed in conductive foam during storage or handling to prevent electrostatic damage to the MOS gates.

12.5 Glossary

[SLYZ022](#) — *TI Glossary*.

This glossary lists and explains terms, acronyms, and definitions.

13 Mechanical, Packaging, and Orderable Information

The following pages include mechanical, packaging, and orderable information. This information is the most current data available for the designated devices. This data is subject to change without notice and revision of this document. For browser-based versions of this data sheet, refer to the left-hand navigation.

PACKAGING INFORMATION

| Orderable Device | Status (1) | Package Type | Package Drawing | Pins | Package Qty | Eco Plan (2) | Lead/Ball Finish (6) | MSL Peak Temp (3) | Op Temp (°C) | Device Marking (4/5) | Samples |
|------------------|---------------|--------------|-----------------|------|-------------|-------------------------|-------------------------|----------------------|--------------|-------------------------|-------------------------|
| LSF0101DRYR | ACTIVE | SON | DRY | 6 | 5000 | Green (RoHS & no Sb/Br) | CU NIPDAU | Level-1-260C-UNLIM | -40 to 125 | VD | Samples |
| LSF0101DTQR | PREVIEW | X2SON | DTQ | 6 | 3000 | Green (RoHS & no Sb/Br) | CU NIPDAU | Level-1-260C-UNLIM | -40 to 125 | FC | |
| LSF0102DCTR | ACTIVE | SM8 | DCT | 8 | 3000 | Green (RoHS & no Sb/Br) | CU NIPDAU | Level-1-260C-UNLIM | -40 to 125 | NG2 (S, Y) | Samples |
| LSF0102DCUR | ACTIVE | VSSOP | DCU | 8 | 3000 | Green (RoHS & no Sb/Br) | CU NIPDAU CU SN | Level-1-260C-UNLIM | -40 to 125 | (G2, NG2P, NG2S) NY | Samples |
| LSF0102DQER | ACTIVE | X2SON | DQE | 8 | 5000 | Green (RoHS & no Sb/Br) | CU NIPDAU | Level-1-260C-UNLIM | -40 to 125 | RV | Samples |
| LSF0102YZTR | ACTIVE | DSBGA | YZT | 8 | 3000 | Green (RoHS & no Sb/Br) | SNAGCU | Level-1-260C-UNLIM | -40 to 125 | RV | Samples |
| LSF0108PWR | ACTIVE | TSSOP | PW | 20 | 2000 | Green (RoHS & no Sb/Br) | CU SN | Level-1-260C-UNLIM | -40 to 125 | LSF0108 | Samples |
| LSF0108RKS | ACTIVE | VQFN | RKS | 20 | 3000 | Green (RoHS & no Sb/Br) | CU NIPDAU | Level-1-260C-UNLIM | -40 to 125 | LSF0108 | Samples |
| PLSF0101DTQR | ACTIVE | X2SON | DTQ | 6 | 3000 | TBD | Call TI | Call TI | -40 to 125 | | Samples |

(1) The marketing status values are defined as follows:

ACTIVE: Product device recommended for new designs.

LIFEBUY: TI has announced that the device will be discontinued, and a lifetime-buy period is in effect.

NRND: Not recommended for new designs. Device is in production to support existing customers, but TI does not recommend using this part in a new design.

PREVIEW: Device has been announced but is not in production. Samples may or may not be available.

OBSELETE: TI has discontinued the production of the device.

(2) **RoHS:** TI defines "RoHS" to mean semiconductor products that are compliant with the current EU RoHS requirements for all 10 RoHS substances, including the requirement that RoHS substance do not exceed 0.1% by weight in homogeneous materials. Where designed to be soldered at high temperatures, "RoHS" products are suitable for use in specified lead-free processes. TI may reference these types of products as "Pb-Free".

RoHS Exempt: TI defines "RoHS Exempt" to mean products that contain lead but are compliant with EU RoHS pursuant to a specific EU RoHS exemption.

Green: TI defines "Green" to mean the content of Chlorine (Cl) and Bromine (Br) based flame retardants meet JS709B low halogen requirements of <=1000ppm threshold. Antimony trioxide based flame retardants must also meet the <=1000ppm threshold requirement.

(3) MSL, Peak Temp. - The Moisture Sensitivity Level rating according to the JEDEC industry standard classifications, and peak solder temperature.

(4) There may be additional marking, which relates to the logo, the lot trace code information, or the environmental category on the device.

⁽⁵⁾ Multiple Device Markings will be inside parentheses. Only one Device Marking contained in parentheses and separated by a "~" will appear on a device. If a line is indented then it is a continuation of the previous line and the two combined represent the entire Device Marking for that device.

⁽⁶⁾ Lead/Ball Finish - Orderable Devices may have multiple material finish options. Finish options are separated by a vertical ruled line. Lead/Ball Finish values may wrap to two lines if the finish value exceeds the maximum column width.

Important Information and Disclaimer: The information provided on this page represents TI's knowledge and belief as of the date that it is provided. TI bases its knowledge and belief on information provided by third parties, and makes no representation or warranty as to the accuracy of such information. Efforts are underway to better integrate information from third parties. TI has taken and continues to take reasonable steps to provide representative and accurate information but may not have conducted destructive testing or chemical analysis on incoming materials and chemicals. TI and TI suppliers consider certain information to be proprietary, and thus CAS numbers and other limited information may not be available for release.

In no event shall TI's liability arising out of such information exceed the total purchase price of the TI part(s) at issue in this document sold by TI to Customer on an annual basis.

OTHER QUALIFIED VERSIONS OF LSF0102, LSF0108 :

- Automotive: [LSF0102-Q1](#), [LSF0108-Q1](#)

NOTE: Qualified Version Definitions:

- Automotive - Q100 devices qualified for high-reliability automotive applications targeting zero defects

TAPE AND REEL INFORMATION

QUADRANT ASSIGNMENTS FOR PIN 1 ORIENTATION IN TAPE



*All dimensions are nominal

| Device | Package Type | Package Drawing | Pins | SPQ | Reel Diameter (mm) | Reel Width W1 (mm) | A0 (mm) | B0 (mm) | K0 (mm) | P1 (mm) | W (mm) | Pin1 Quadrant |
|-------------|--------------|-----------------|------|------|--------------------|--------------------|---------|---------|---------|---------|--------|---------------|
| LSF0101DRYR | SON | DRY | 6 | 5000 | 180.0 | 9.5 | 1.15 | 1.6 | 0.75 | 4.0 | 8.0 | Q1 |
| LSF0102DCTR | SM8 | DCT | 8 | 3000 | 180.0 | 13.0 | 3.35 | 4.5 | 1.55 | 4.0 | 12.0 | Q3 |
| LSF0102DCUR | VSSOP | DCU | 8 | 3000 | 180.0 | 9.0 | 2.05 | 3.3 | 1.0 | 4.0 | 8.0 | Q3 |
| LSF0102DCUR | VSSOP | DCU | 8 | 3000 | 180.0 | 8.4 | 2.25 | 3.35 | 1.05 | 4.0 | 8.0 | Q3 |
| LSF0102DQER | X2SON | DQE | 8 | 5000 | 180.0 | 9.5 | 1.15 | 1.6 | 0.5 | 4.0 | 8.0 | Q1 |
| LSF0102YZTR | DSBGA | YZT | 8 | 3000 | 180.0 | 8.4 | 1.02 | 2.02 | 0.75 | 4.0 | 8.0 | Q1 |
| LSF0108PWR | TSSOP | PW | 20 | 2000 | 330.0 | 16.4 | 6.95 | 7.1 | 1.6 | 8.0 | 16.0 | Q1 |
| LSF0108RKSR | VQFN | RKS | 20 | 3000 | 177.8 | 12.4 | 2.73 | 4.85 | 1.03 | 4.0 | 12.0 | Q1 |

TAPE AND REEL BOX DIMENSIONS

*All dimensions are nominal

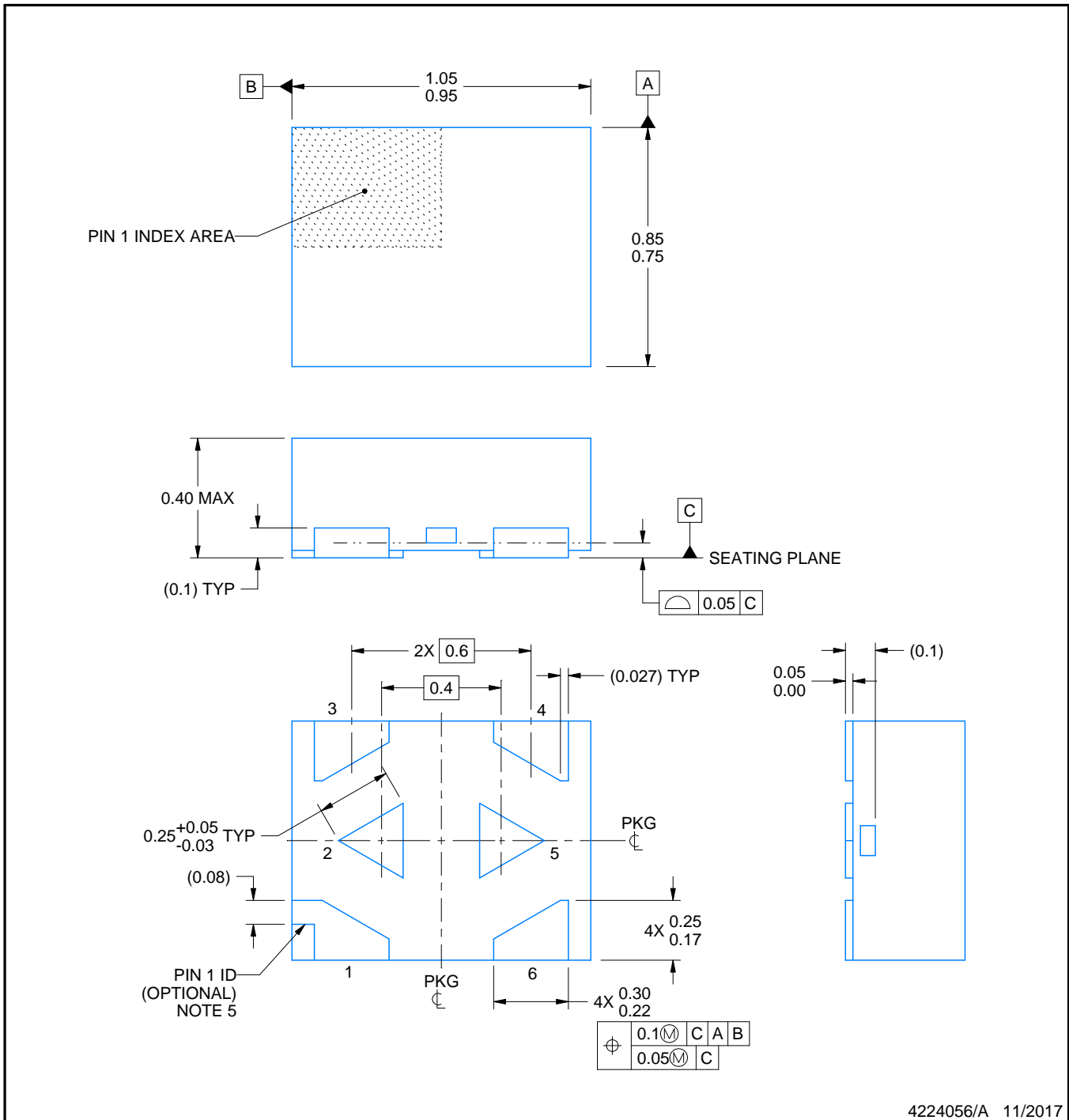
| Device | Package Type | Package Drawing | Pins | SPQ | Length (mm) | Width (mm) | Height (mm) |
|-------------|--------------|-----------------|------|------|-------------|------------|-------------|
| LSF0101DRYR | SON | DRY | 6 | 5000 | 184.0 | 184.0 | 19.0 |
| LSF0102DCTR | SM8 | DCT | 8 | 3000 | 182.0 | 182.0 | 20.0 |
| LSF0102DCUR | VSSOP | DCU | 8 | 3000 | 182.0 | 182.0 | 20.0 |
| LSF0102DCUR | VSSOP | DCU | 8 | 3000 | 202.0 | 201.0 | 28.0 |
| LSF0102DQER | X2SON | DQE | 8 | 5000 | 184.0 | 184.0 | 19.0 |
| LSF0102YZTR | DSBGA | YZT | 8 | 3000 | 182.0 | 182.0 | 20.0 |
| LSF0108PWR | TSSOP | PW | 20 | 2000 | 364.0 | 364.0 | 27.0 |
| LSF0108RKS | VQFN | RKS | 20 | 3000 | 202.0 | 201.0 | 28.0 |



NOTES:

1. All linear dimensions are in millimeters. Any dimensions in parenthesis are for reference only. Dimensioning and tolerancing per ASME Y14.5M.
2. This drawing is subject to change without notice.
3. The package thermal pads must be soldered to the printed circuit board for optimal thermal and mechanical performance.
4. The size and shape of this feature may vary.
5. Features may not exist. Recommend use of pin 1 marking on top of package for orientation purposes.

EXAMPLE BOARD LAYOUT

DTQ0006A

X2SON - 0.4 mm max height

PLASTIC SMALL OUTLINE - NO LEAD

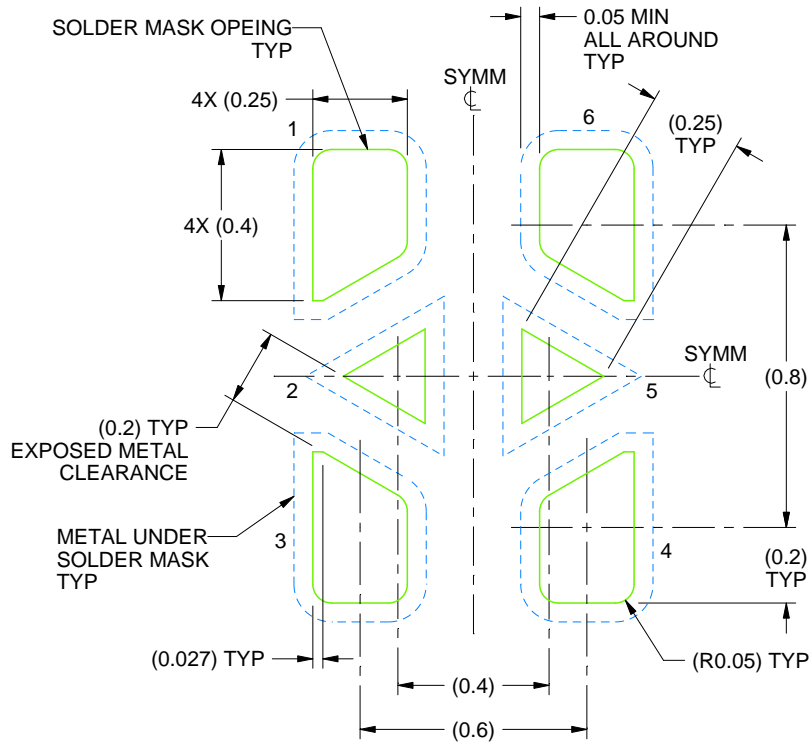

LAND PATTERN EXAMPLE
SOLDER MASK DEFINED
SCALE:50X

4224056/A 11/2017

NOTES: (continued)

6. This package is designed to be soldered to a thermal pads on the board. For more information, see Texas Instruments literature number SLUA271 (www.ti.com/lit/slue271).
7. Vias are optional depending on application, refer to device data sheet. If some or all are implemented, recommended via locations are shown.

EXAMPLE STENCIL DESIGN

DTQ0006A

X2SON - 0.4 mm max height

PLASTIC SMALL OUTLINE - NO LEAD

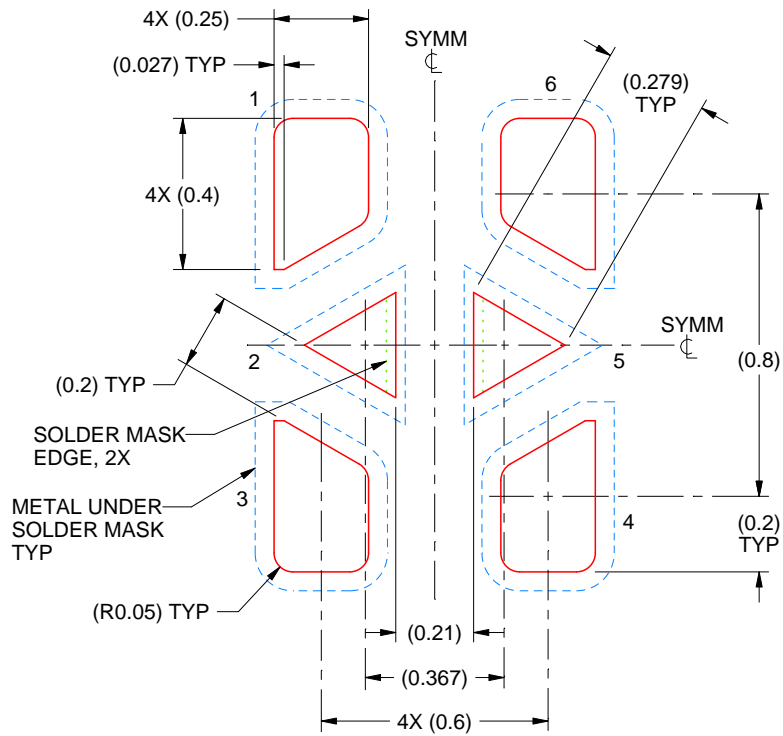

SOLDER PASTE EXAMPLE
BASED ON 0.07 mm THICK STENCIL

PRINTED SOLDER COVERAGE BY AREA UNDER PACKAGE
SCALE:50X

4224056/A 11/2017

NOTES: (continued)



8. Laser cutting apertures with trapezoidal walls and rounded corners may offer better paste release. IPC-7525 may have alternate design recommendations.

PW (R-PDSO-G20)

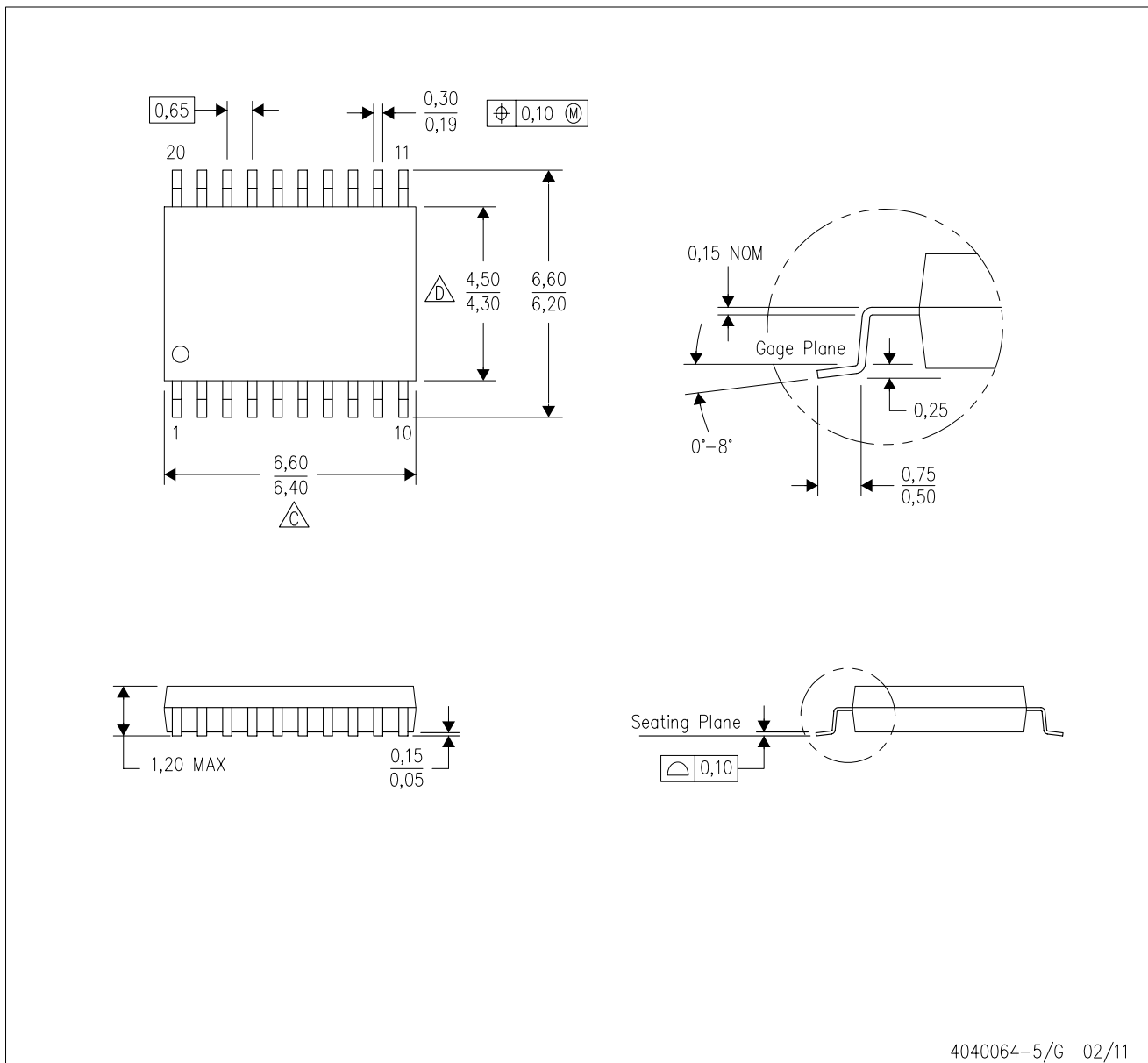
PLASTIC SMALL OUTLINE



4040064-5/G 02/11

- NOTES:
- A. All linear dimensions are in millimeters. Dimensioning and tolerancing per ASME Y14.5M-1994.
 - B. This drawing is subject to change without notice.
 -  Body length does not include mold flash, protrusions, or gate burrs. Mold flash, protrusions, or gate burrs shall not exceed 0,15 each side.
 -  Body width does not include interlead flash. Interlead flash shall not exceed 0,25 each side.
 - E. Falls within JEDEC MO-153

PW (R-PDSO-G20)

PLASTIC SMALL OUTLINE



- NOTES:
- A. All linear dimensions are in millimeters.
 - B. This drawing is subject to change without notice.
 - C. Publication IPC-7351 is recommended for alternate design.
 - D. Laser cutting apertures with trapezoidal walls and also rounding corners will offer better paste release. Customers should contact their board assembly site for stencil design recommendations. Refer to IPC-7525 for other stencil recommendations.
 - E. Customers should contact their board fabrication site for solder mask tolerances between and around signal pads.

DQE (R-PX2SON-N8)

PLASTIC SMALL OUTLINE NO-LEAD

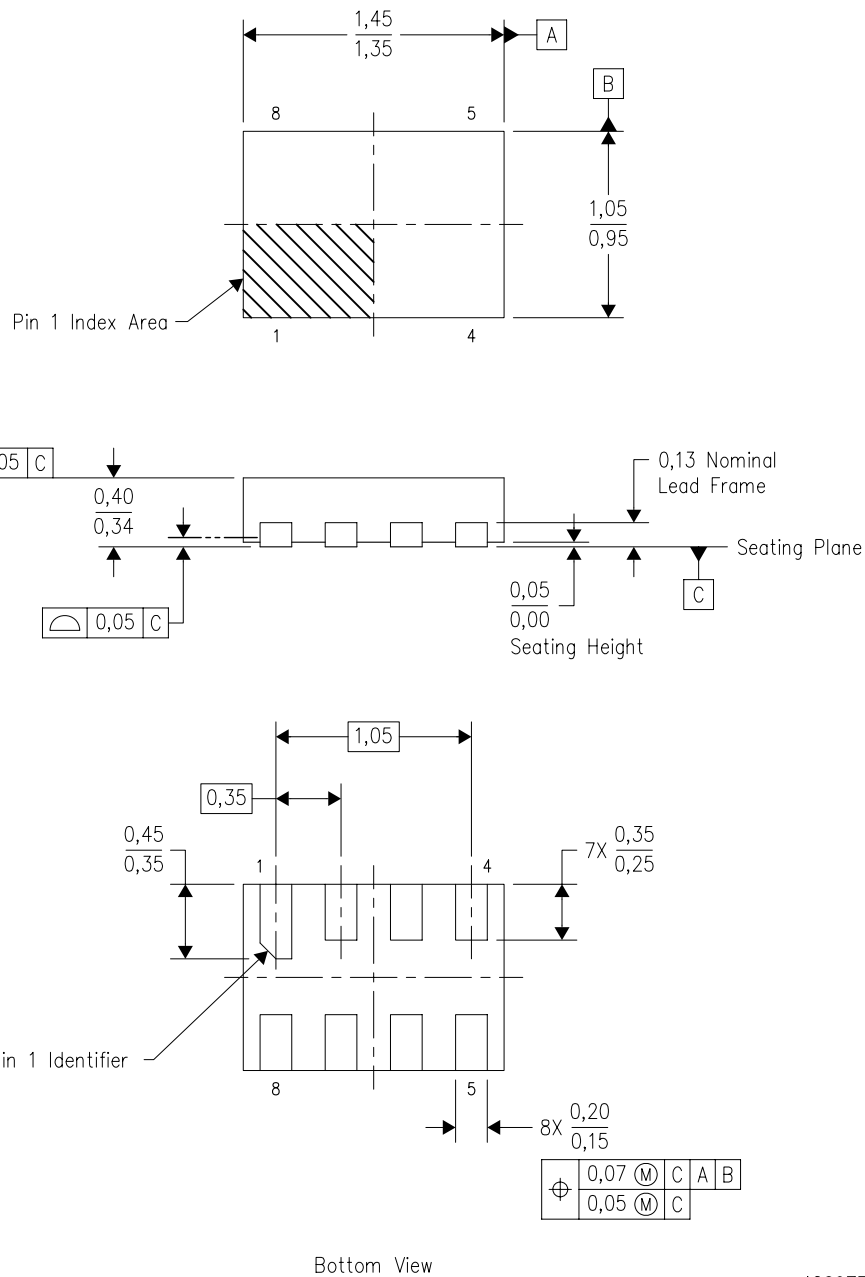

4209779/B 10/2008

- NOTES:
- All linear dimensions are in millimeters. Dimensioning and tolerancing per ASME Y14.5M-1994.
 - This drawing is subject to change without notice.
 - SON (Small Outline No-Lead) package configuration.
 - This package complies to JEDEC MO-287 variation X2EAF.

DQE (R-PX2SON-N8)

PLASTIC SMALL OUTLINE NO-LEAD

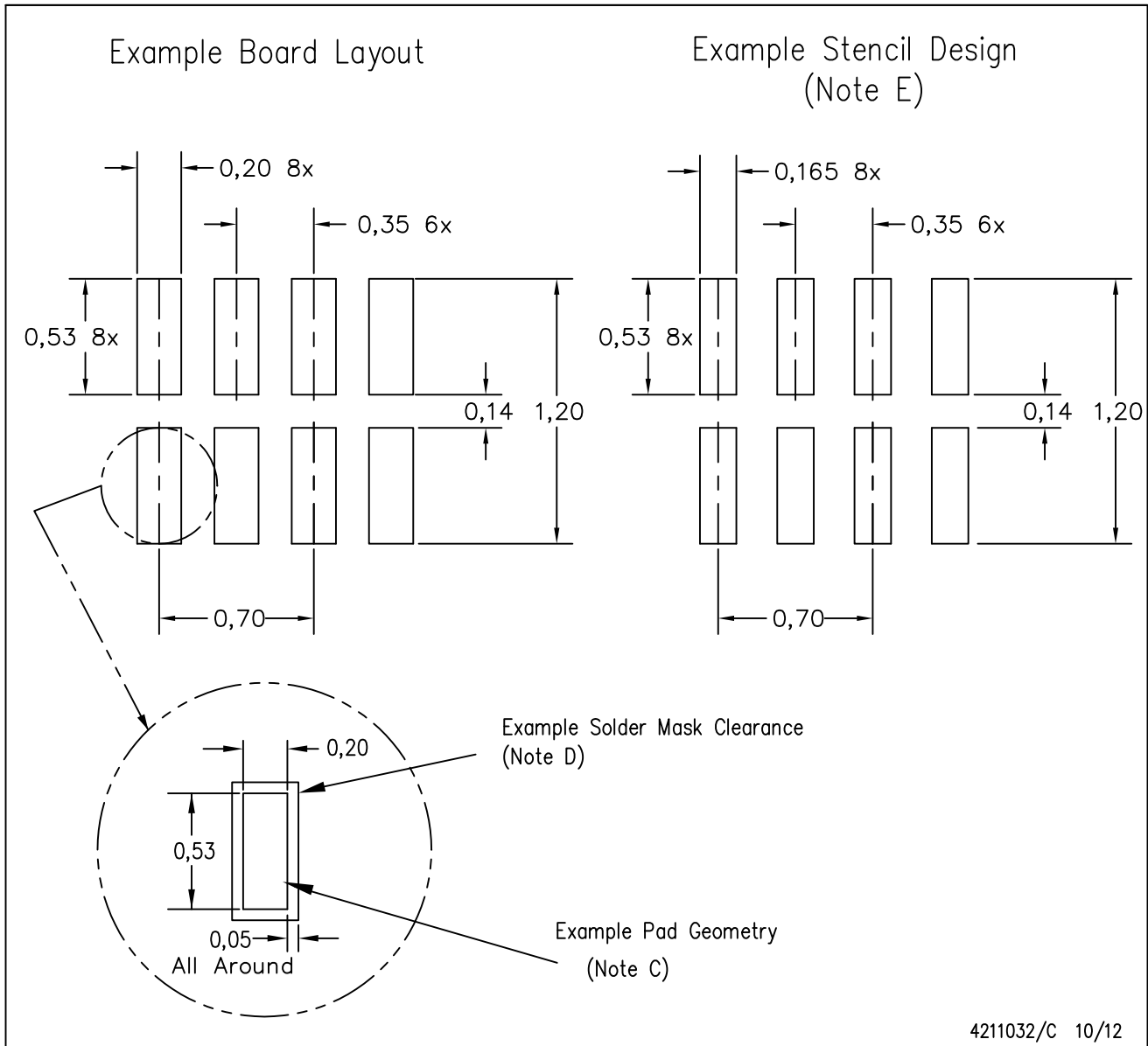

- NOTES:
- A. All linear dimensions are in millimeters.
 - B. This drawing is subject to change without notice.
 - C. Publication IPC-7351 is recommended for alternate designs.
 - D. Customers should contact their board fabrication site for minimum solder mask web tolerances between signal pads.
If 2 mil solder mask is outside PCB vendor capability, it is advised to omit solder mask.
 - E. Maximum stencil thickness 0,1016 mm (4 mils). All linear dimensions are in millimeters.
 - F. Laser cutting apertures with trapezoidal walls and also rounding corners will offer better paste release. Customers should contact their board assembly site for stencil design recommendations. Refer to IPC 7525 for stencil design considerations.
 - G. Over-printing land for acceptable area ratio is not viable due to land width and bridging potential. Customer may further reduce side aperture dimensions if stencil manufacturing process allows for sufficient release at smaller opening.
 - H. Suggest stencils cut with lasers such as Fiber Laser that produce the greatest positional accuracy.
 - I. Component placement force should be minimized to prevent excessive paste block deformation.

DCT (R-PDSO-G8)

PLASTIC SMALL-OUTLINE PACKAGE

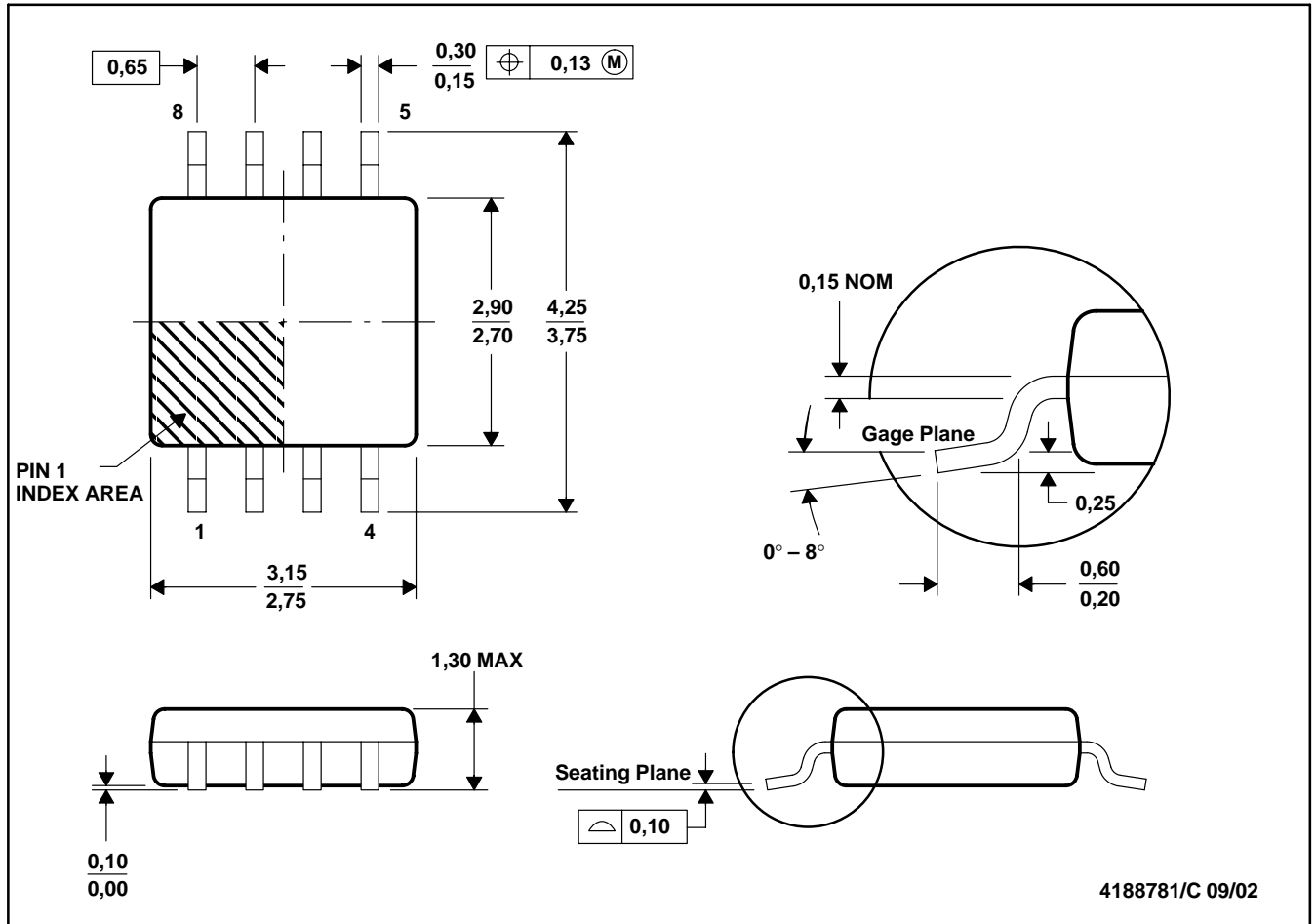

- NOTES:
- A. All linear dimensions are in millimeters.
 - B. This drawing is subject to change without notice.
 - C. Body dimensions do not include mold flash or protrusion
 - D. Falls within JEDEC MO-187 variation DA.

DCT (R-PDSO-G8)

PLASTIC SMALL OUTLINE

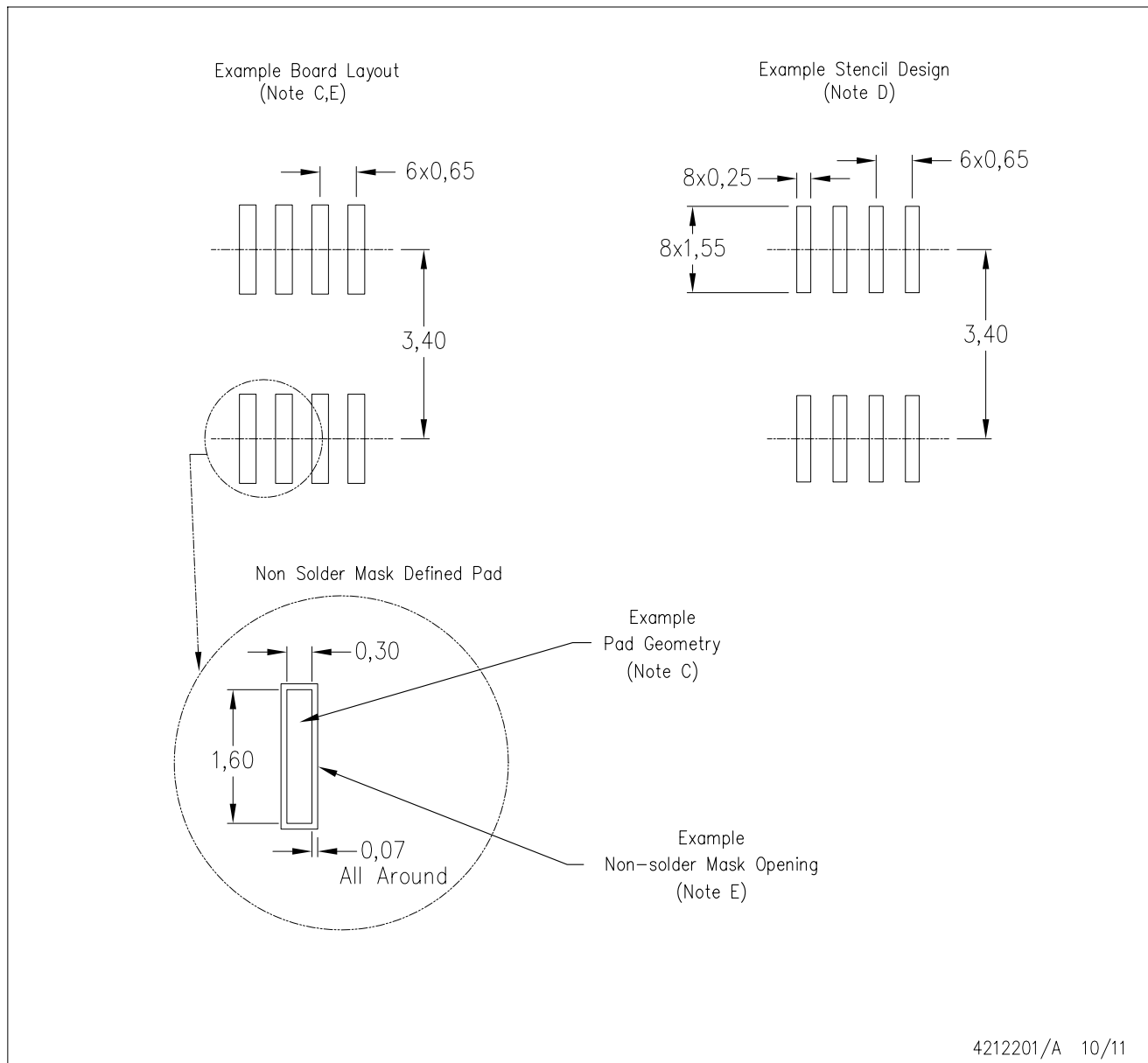

- NOTES: A. All linear dimensions are in millimeters.
 B. This drawing is subject to change without notice.
 C. Publication IPC-7351 is recommended for alternate designs.
 D. Laser cutting apertures with trapezoidal walls and also rounding corners will offer better paste release. Customers should contact their board assembly site for stencil design recommendations. Refer to IPC-7525.
 E. Customers should contact their board fabrication site for solder mask tolerances between and around signal pads.

DCU (S-PDSO-G8)

PLASTIC SMALL OUTLINE PACKAGE (DIE DOWN)

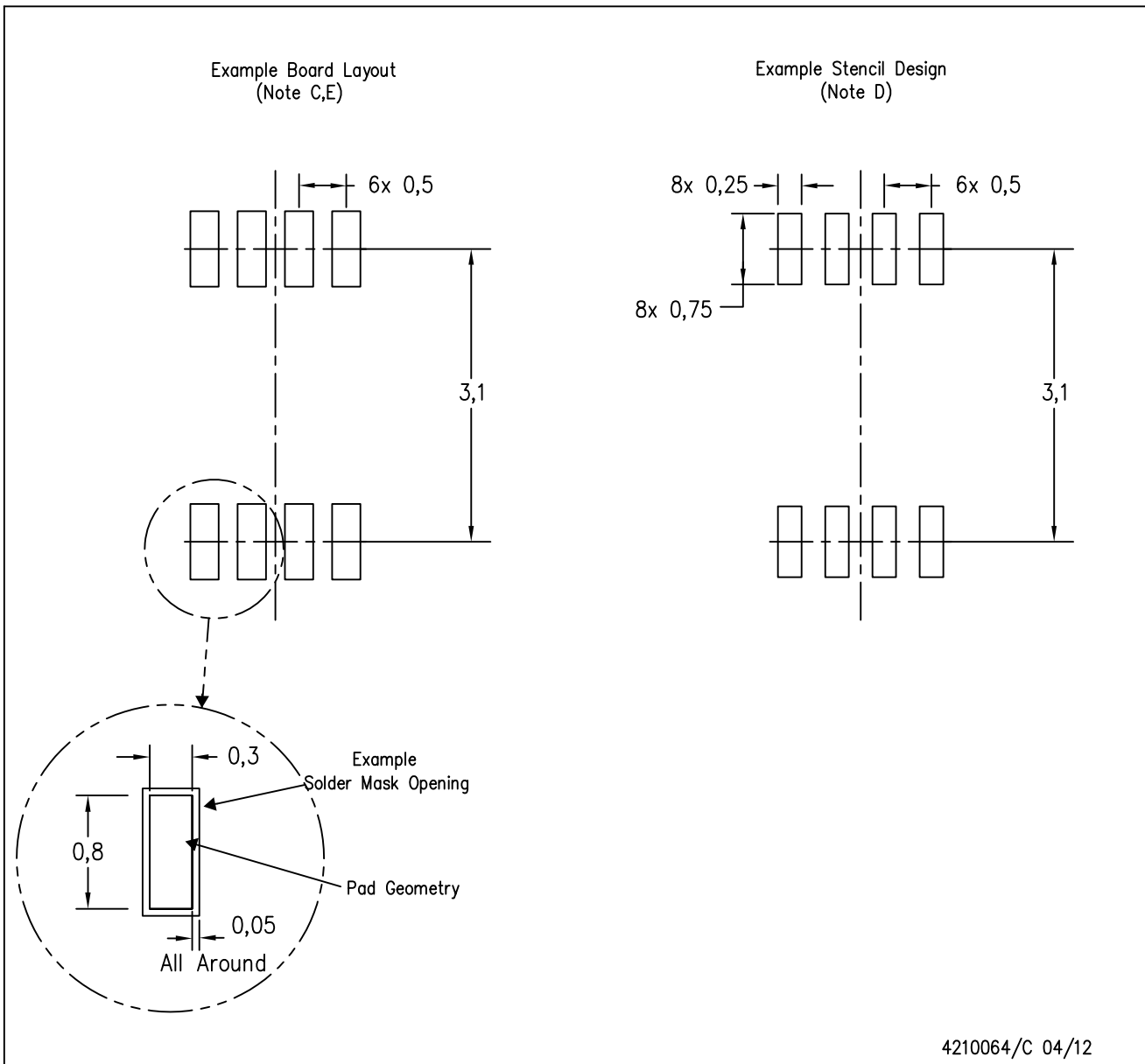

4210064/C 04/12

- NOTES:
- A. All linear dimensions are in millimeters.
 - B. This drawing is subject to change without notice.
 - C. Publication IPC-7351 is recommended for alternate designs.
 - D. Laser cutting apertures with trapezoidal walls and also rounding corners will offer better paste release. Customers should contact their board assembly site for stencil design recommendations. Refer to IPC-7525 for other stencil recommendations.
 - E. Customers should contact their board fabrication site for solder mask tolerances between and around signal pads.

GENERIC PACKAGE VIEW

DRY 6

USON - 0.6 mm max height

PLASTIC SMALL OUTLINE - NO LEAD



Images above are just a representation of the package family, actual package may vary.
Refer to the product data sheet for package details.

4207181/G

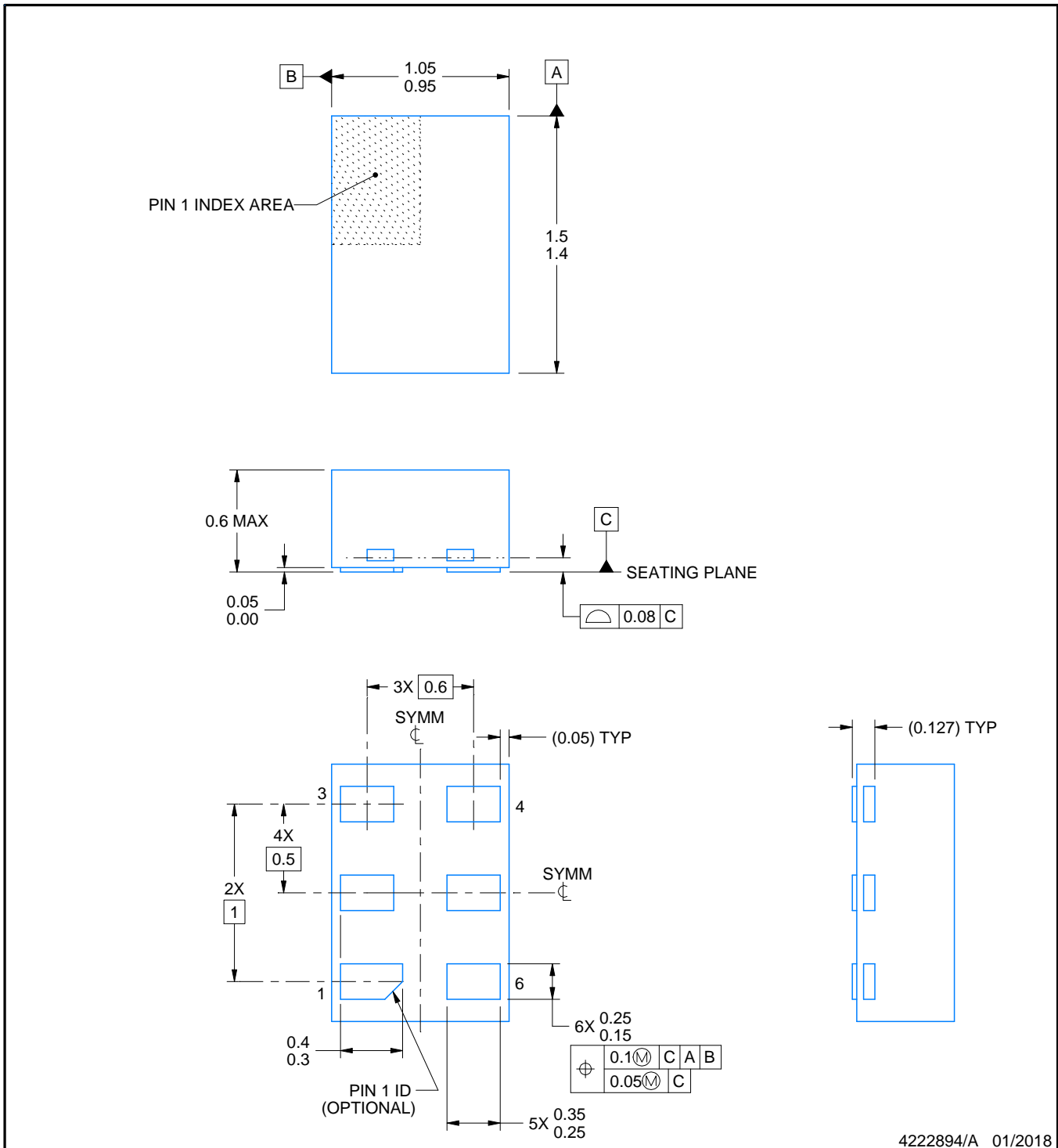

NOTES:

1. All linear dimensions are in millimeters. Any dimensions in parenthesis are for reference only. Dimensioning and tolerancing per ASME Y14.5M.
2. This drawing is subject to change without notice.

EXAMPLE BOARD LAYOUT

DRY0006A

USON - 0.6 mm max height

PLASTIC SMALL OUTLINE - NO LEAD

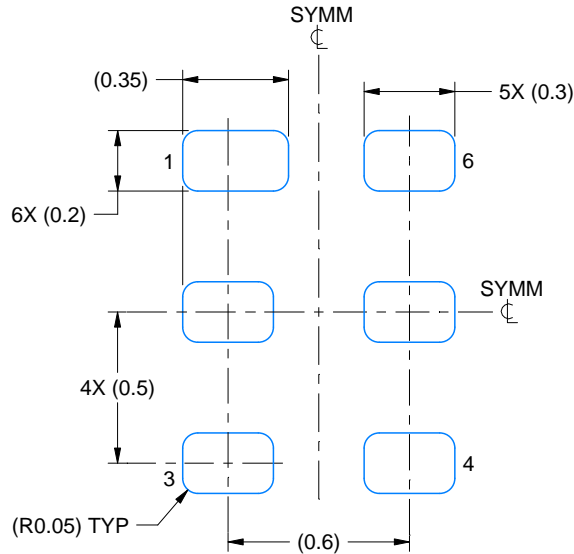

LAND PATTERN EXAMPLE
1:1 RATIO WITH PKG SOLDER PADS
EXPOSED METAL SHOWN
SCALE:40X

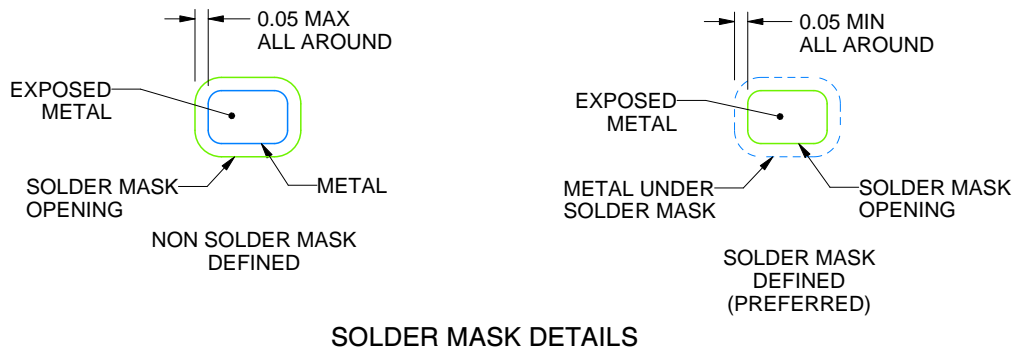

SOLDER MASK DETAILS

4222894/A 01/2018

NOTES: (continued)

3. For more information, see QFN/SON PCB application report in literature No. SLUA271 (www.ti.com/lit/slue271).

EXAMPLE STENCIL DESIGN

DRY0006A

USON - 0.6 mm max height

PLASTIC SMALL OUTLINE - NO LEAD



SOLDER PASTE EXAMPLE
BASED ON 0.075 - 0.1 mm THICK STENCIL
SCALE:40X

4222894/A 01/2018

NOTES: (continued)

4. Laser cutting apertures with trapezoidal walls and rounded corners may offer better paste release. IPC-7525 may have alternate design recommendations.

RKS (R-PVQFN-N20)

PLASTIC QUAD FLATPACK NO-LEAD

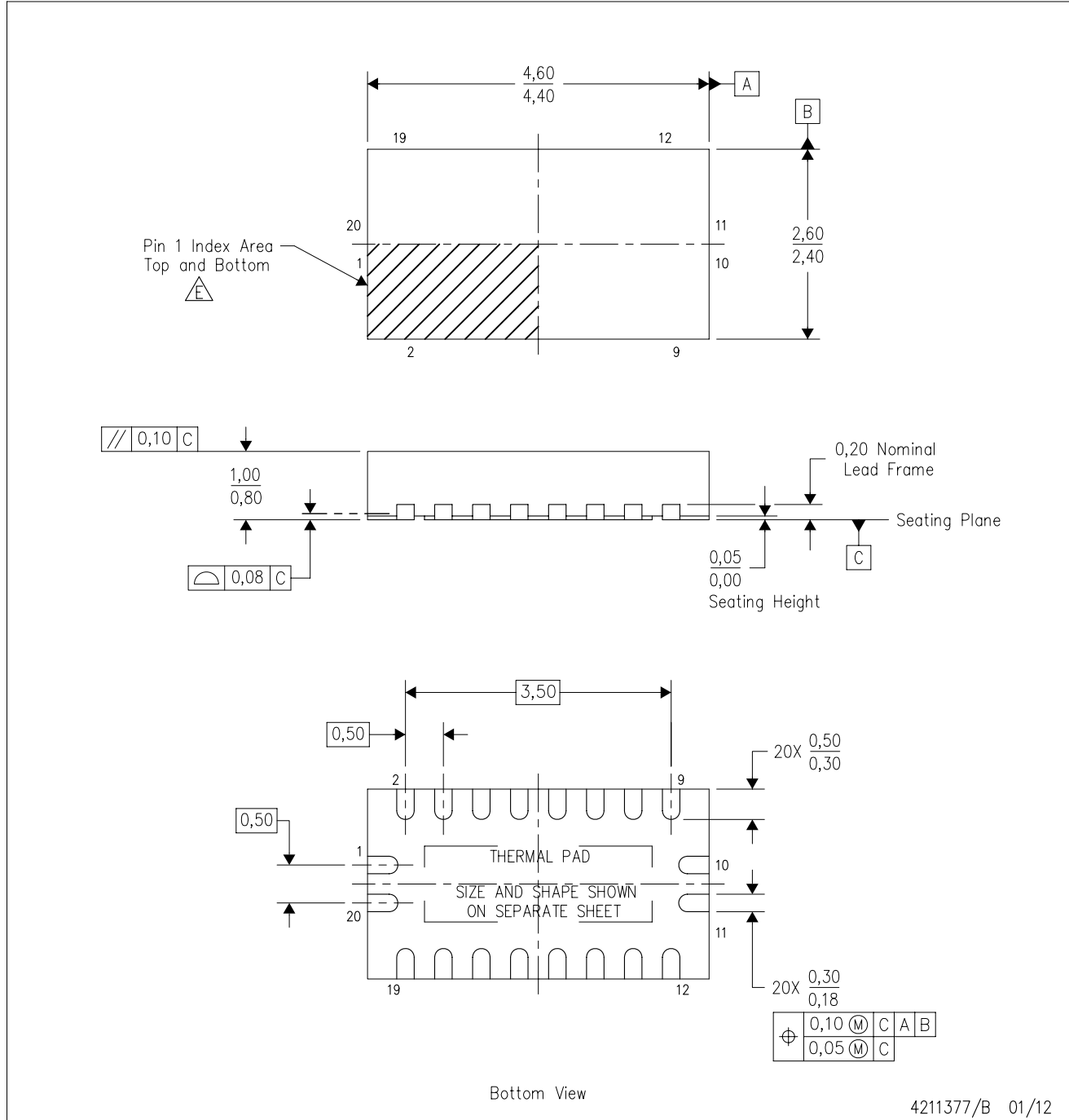

- NOTES:
- A. All linear dimensions are in millimeters. Dimensioning and tolerancing per ASME Y14.5M-1994.
 - B. This drawing is subject to change without notice.
 - C. QFN (Quad Flatpack No-Lead) package configuration.
 - D. The package thermal pad must be soldered to the board for thermal and mechanical performance.
 - E. See the additional figure in the Product Data Sheet for details regarding the exposed thermal pad features and dimensions.
- △ Pin 1 identifiers are located on both top and bottom of the package and within the zone indicated. The Pin 1 identifiers are either a molded, marked, or metal feature.

THERMAL PAD MECHANICAL DATA

RKS (R-PVQFN-N20)

PLASTIC QUAD FLATPACK NO-LEAD

THERMAL INFORMATION

This package incorporates an exposed thermal pad that is designed to be attached directly to an external heatsink. The thermal pad must be soldered directly to the printed circuit board (PCB). After soldering, the PCB can be used as a heatsink. In addition, through the use of thermal vias, the thermal pad can be attached directly to the appropriate copper plane shown in the electrical schematic for the device, or alternatively, can be attached to a special heatsink structure designed into the PCB. This design optimizes the heat transfer from the integrated circuit (IC).

For information on the Quad Flatpack No-Lead (QFN) package and its advantages, refer to Application Report, QFN/SON PCB Attachment, Texas Instruments Literature No. SLUA271. This document is available at www.ti.com.

The exposed thermal pad dimensions for this package are shown in the following illustration.

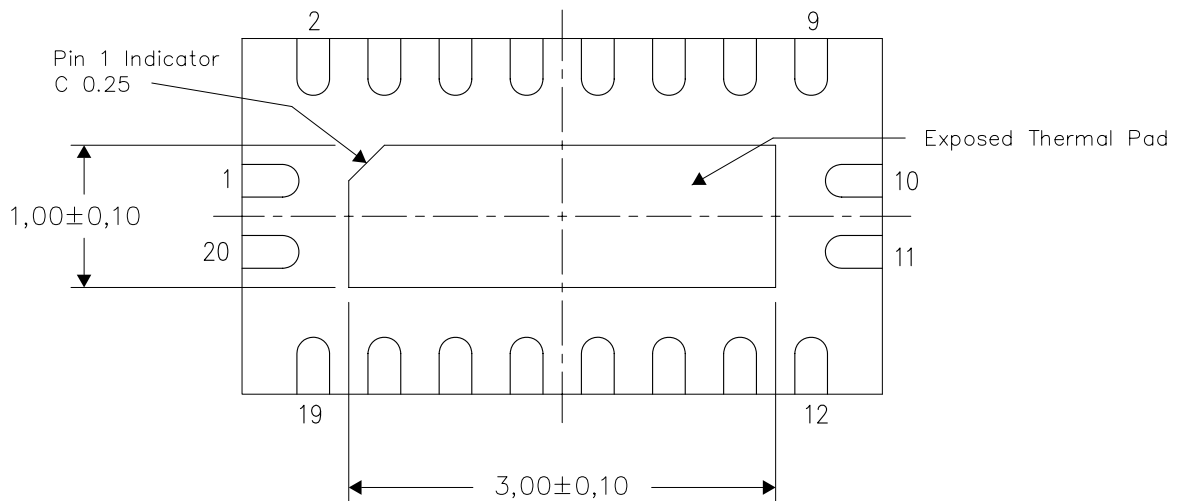

Bottom View

Exposed Thermal Pad Dimensions

4211394/B 01/12

NOTE: All linear dimensions are in millimeters

MECHANICAL DATA

YZT (R-XBGA-N8)

DIE-SIZE BALL GRID ARRAY

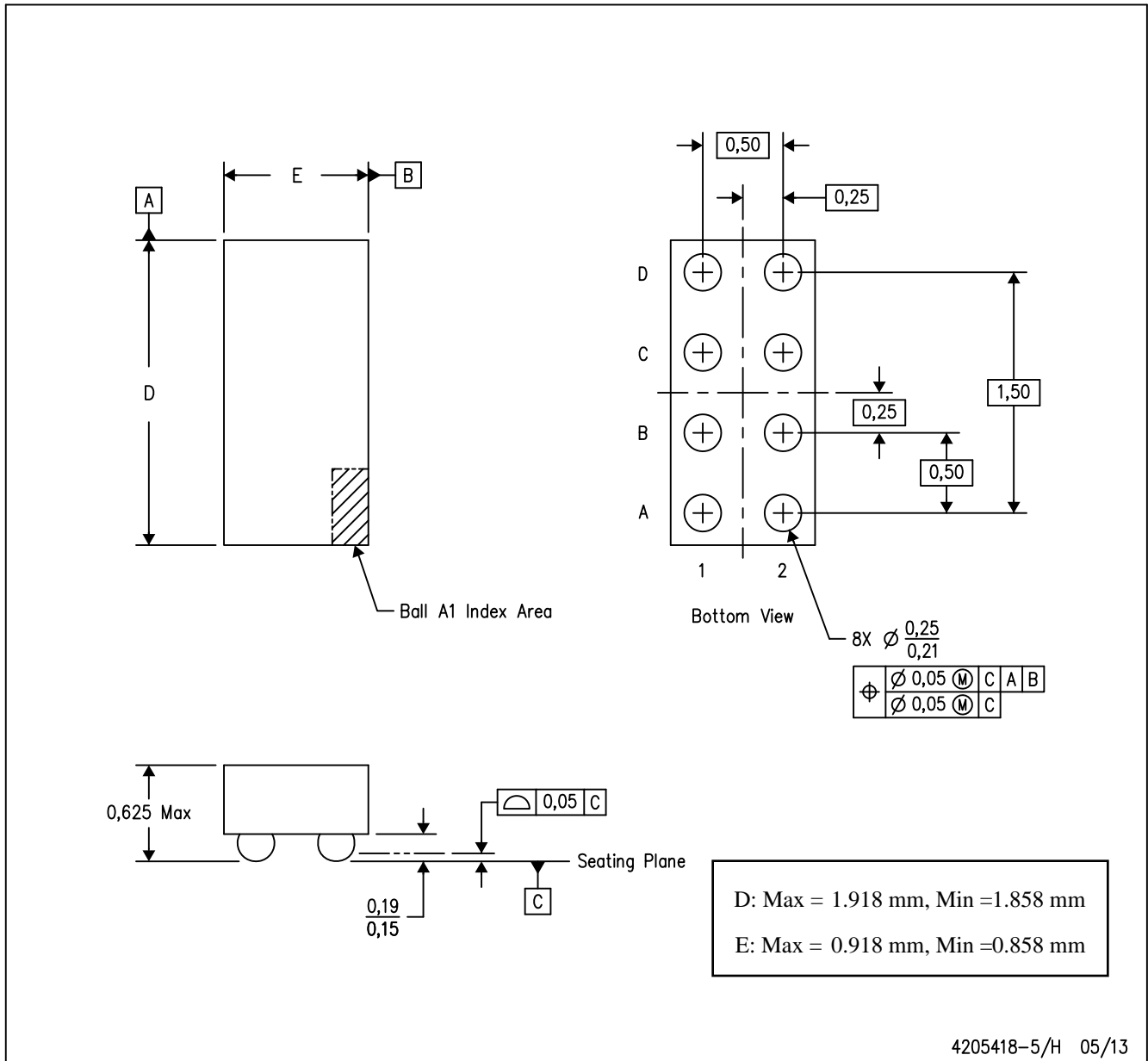

- NOTES:
- A. All linear dimensions are in millimeters. Dimensioning and tolerancing per ASME Y14.5M-1994.
 - B. This drawing is subject to change without notice.
 - C. NanoFree™ package configuration.

NanoFree is a trademark of Texas Instruments.

IMPORTANT NOTICE AND DISCLAIMER

TI PROVIDES TECHNICAL AND RELIABILITY DATA (INCLUDING DATASHEETS), DESIGN RESOURCES (INCLUDING REFERENCE DESIGNS), APPLICATION OR OTHER DESIGN ADVICE, WEB TOOLS, SAFETY INFORMATION, AND OTHER RESOURCES "AS IS" AND WITH ALL FAULTS, AND DISCLAIMS ALL WARRANTIES, EXPRESS AND IMPLIED, INCLUDING WITHOUT LIMITATION ANY IMPLIED WARRANTIES OF MERCHANTABILITY, FITNESS FOR A PARTICULAR PURPOSE OR NON-INFRINGEMENT OF THIRD PARTY INTELLECTUAL PROPERTY RIGHTS.

These resources are intended for skilled developers designing with TI products. You are solely responsible for (1) selecting the appropriate TI products for your application, (2) designing, validating and testing your application, and (3) ensuring your application meets applicable standards, and any other safety, security, or other requirements. These resources are subject to change without notice. TI grants you permission to use these resources only for development of an application that uses the TI products described in the resource. Other reproduction and display of these resources is prohibited. No license is granted to any other TI intellectual property right or to any third party intellectual property right. TI disclaims responsibility for, and you will fully indemnify TI and its representatives against, any claims, damages, costs, losses, and liabilities arising out of your use of these resources.

TI's products are provided subject to TI's Terms of Sale (www.ti.com/legal/termsofsale.html) or other applicable terms available either on ti.com or provided in conjunction with such TI products. TI's provision of these resources does not expand or otherwise alter TI's applicable warranties or warranty disclaimers for TI products.

Mailing Address: Texas Instruments, Post Office Box 655303, Dallas, Texas 75265
Copyright © 2019, Texas Instruments Incorporated

Looking for pricing, stock, or lifecycle information?

Click below to explore more details on WIN SOURCE:

 [View LSF0108PWR](#) on WIN SOURCE

 [Texas Instruments](#) Information

Optimize Your Supply Chain with WIN SOURCE Solutions

-  Global Sourcing Solution
-  Obsolete Management
-  Cost Control Management
-  Shortage Management
-  Alternative Solution
-  Excess Inventory Management