



**THE DATASHEET OF  
LS103B-GS08**





## Small Signal Schottky Diodes



**DESIGN SUPPORT TOOLS** click logo to get started



### MECHANICAL DATA

**Case:** QuadroMELF (SOD-80)

**Weight:** approx. 34 mg

**Cathode band color:** black

**Packaging codes/options:**

GS18/10K per 13" reel (8 mm tape), 10K/box

GS08/2.5K per 7" reel (8 mm tape), 12.5K/box

### FEATURES

- Integrated protection ring against static discharge
- Low capacitance
- Low leakage current
- Low forward voltage drop
- AEC-Q101 qualified
- Material categorization: for definitions of compliance please see [www.vishay.com/doc?99912](http://www.vishay.com/doc?99912)



**RoHS**  
COMPLIANT

### APPLICATIONS

- HF-detector
- Protection circuit
- Small battery charger
- AC/DC / DC/DC converter for notebooks

| PARTS TABLE |                      |                            |                       |               |
|-------------|----------------------|----------------------------|-----------------------|---------------|
| PART        | TYPE DIFFERENTIATION | ORDERING CODE              | CIRCUIT CONFIGURATION | REMARKS       |
| LS103A      | $V_R = 40\text{ V}$  | LS103A-GS18 or LS103A-GS08 | Single                | Tape and reel |
| LS103B      | $V_R = 30\text{ V}$  | LS103B-GS18 or LS103B-GS08 | Single                | Tape and reel |
| LS103C      | $V_R = 20\text{ V}$  | LS103C-GS18 or LS103C-GS08 | Single                | Tape and reel |

| ABSOLUTE MAXIMUM RATINGS ( $T_{amb} = 25\text{ }^\circ\text{C}$ , unless otherwise specified) |   |        |           |       |      |
|---|---|--------|-----------|-------|------|
| PARAMETER   | TEST CONDITION                                | PART   | SYMBOL    | VALUE | UNIT |
| Reverse voltage   |   | LS103A | $V_R$     | 40    | V    |
|   |   | LS103B | $V_R$     | 30    | V    |
|   |   | LS103C | $V_R$     | 20    | V    |
| Peak forward surge current  | $t_p = 300\text{ }\mu\text{s}$ , square pulse |        | $I_{FSM}$ | 15    | A    |
| Power dissipation   |   |        | $P_{tot}$ | 400   | mW   |

| THERMAL CHARACTERISTICS ( $T_{amb} = 25\text{ }^\circ\text{C}$ , unless otherwise specified) |                                       |            |             |                  |
|--|---------------------------------------|------------|-------------|------------------|
| PARAMETER  | TEST CONDITION                        | SYMBOL     | VALUE       | UNIT             |
| Thermal resistance junction to ambient air   | On PC board<br>50 mm x 50 mm x 1.6 mm | $R_{thJA}$ | 250         | K/W              |
| Junction temperature   |                                       | $T_j$      | 125         | $^\circ\text{C}$ |
| Storage temperature range  |                                       | $T_{stg}$  | -65 to +150 | $^\circ\text{C}$ |



| ELECTRICAL CHARACTERISTICS (T <sub>amb</sub> = 25 °C, unless otherwise specified) |  |        |                   |      |      |      |      |
|---|--|--------|-------------------|------|------|------|------|
| PARAMETER   | TEST CONDITION   | SYMBOL | SYMBOL            | MIN. | TYP. | MAX. | UNIT |
| Reverse breakdown voltage   | I <sub>R</sub> = 10 μA   | LS103A | V <sub>(BR)</sub> | 40   |      |      | V    |
|   |  | LS103B | V <sub>(BR)</sub> | 30   |      |      | V    |
|   |  | LS103C | V <sub>(BR)</sub> | 20   |      |      | V    |
| Leakage current   | V <sub>R</sub> = 30 V  | LS103A | I <sub>R</sub>    |      |      | 5    | μA   |
|   | V <sub>R</sub> = 20 V  | LS103B | I <sub>R</sub>    |      |      | 5    | μA   |
|   | V <sub>R</sub> = 10 V  | LS103C | I <sub>R</sub>    |      |      | 5    | μA   |
| Forward voltage drop  | I <sub>F</sub> = 20 mA   |        | V <sub>F</sub>    |      |      | 370  | mV   |
|   | I <sub>F</sub> = 200 mA  |        | V <sub>F</sub>    |      |      | 600  | mV   |
| Diode capacitance   | V <sub>R</sub> = 0 V, f = 1 MHz  |        | C <sub>D</sub>    |      | 50   |      | pF   |
| Reverse recovery time   | I <sub>F</sub> = I <sub>R</sub> = 50 mA to 200 mA, recover to 0.1 I <sub>R</sub> |        | t <sub>rr</sub>   |      | 10   |      | ns   |

**TYPICAL CHARACTERISTICS** (T<sub>amb</sub> = 25 °C, unless otherwise specified)

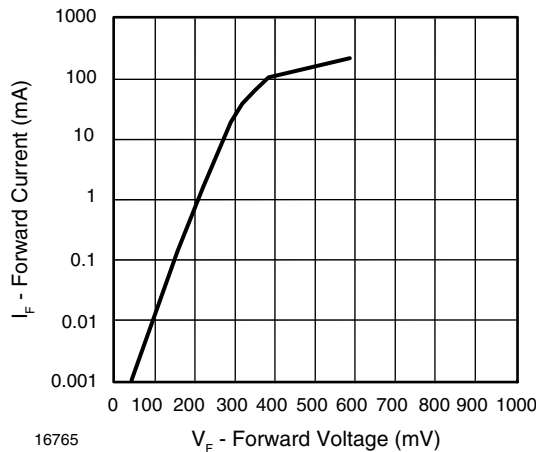

Fig. 1 - Forward Current vs. Forward Voltage

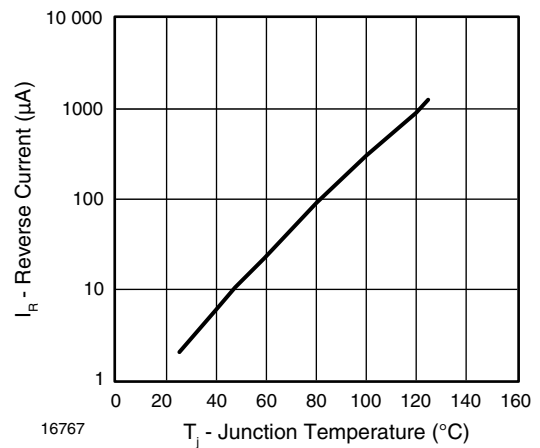

Fig. 3 - Reverse Current vs. Junction Temperature

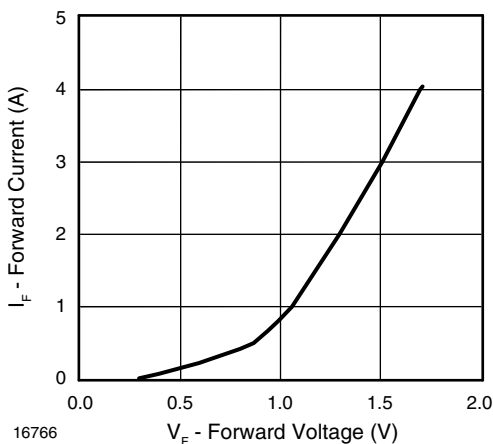

Fig. 2 - Forward Current vs. Forward Voltage

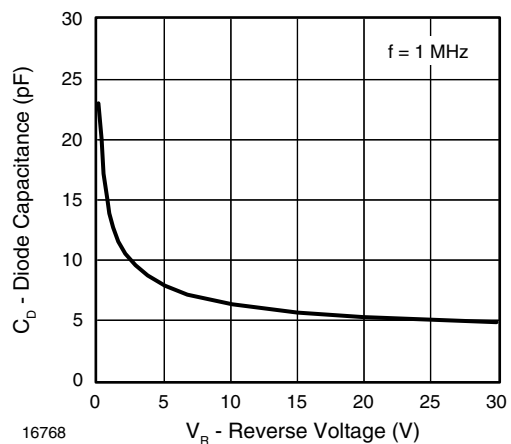

Fig. 4 - Diode Capacitance vs. Reverse Voltage

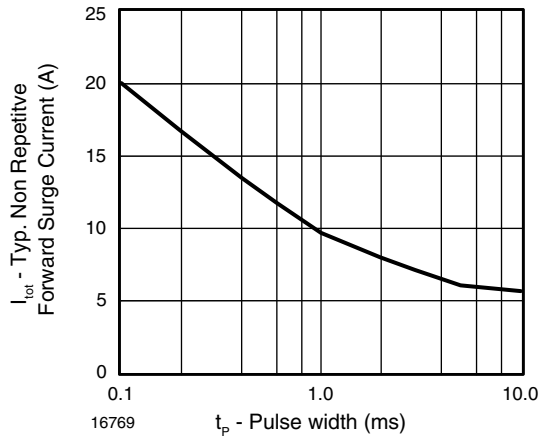
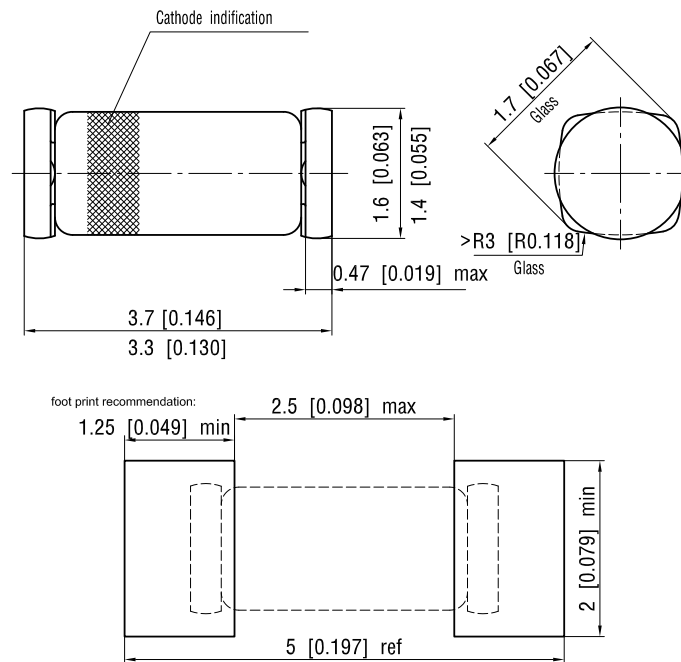

Fig. 5 - Typical Non-Repetitive Forward Surge Current vs. Pulse Width

**PACKAGE DIMENSIONS** in millimeters (inches): **QuadroMELF (SOD-80)**



Document no.: 6.560-5006.01-4  
Rev. 10 - Date: 30.August.2004

12071



## **Disclaimer**

ALL PRODUCT, PRODUCT SPECIFICATIONS AND DATA ARE SUBJECT TO CHANGE WITHOUT NOTICE TO IMPROVE RELIABILITY, FUNCTION OR DESIGN OR OTHERWISE.

Vishay Intertechnology, Inc., its affiliates, agents, and employees, and all persons acting on its or their behalf (collectively, "Vishay"), disclaim any and all liability for any errors, inaccuracies or incompleteness contained in any datasheet or in any other disclosure relating to any product.

Vishay makes no warranty, representation or guarantee regarding the suitability of the products for any particular purpose or the continuing production of any product. To the maximum extent permitted by applicable law, Vishay disclaims (i) any and all liability arising out of the application or use of any product, (ii) any and all liability, including without limitation special, consequential or incidental damages, and (iii) any and all implied warranties, including warranties of fitness for particular purpose, non-infringement and merchantability.

Statements regarding the suitability of products for certain types of applications are based on Vishay's knowledge of typical requirements that are often placed on Vishay products in generic applications. Such statements are not binding statements about the suitability of products for a particular application. It is the customer's responsibility to validate that a particular product with the properties described in the product specification is suitable for use in a particular application. Parameters provided in datasheets and / or specifications may vary in different applications and performance may vary over time. All operating parameters, including typical parameters, must be validated for each customer application by the customer's technical experts. Product specifications do not expand or otherwise modify Vishay's terms and conditions of purchase, including but not limited to the warranty expressed therein.

Except as expressly indicated in writing, Vishay products are not designed for use in medical, life-saving, or life-sustaining applications or for any other application in which the failure of the Vishay product could result in personal injury or death. Customers using or selling Vishay products not expressly indicated for use in such applications do so at their own risk. Please contact authorized Vishay personnel to obtain written terms and conditions regarding products designed for such applications.

No license, express or implied, by estoppel or otherwise, to any intellectual property rights is granted by this document or by any conduct of Vishay. Product names and markings noted herein may be trademarks of their respective owners.

## Looking for pricing, stock, or lifecycle information?

Click below to explore more details on WIN SOURCE:

 [View LS103B-GS08 on WIN SOURCE](#)

 [Vishay Information](#)

## Optimize Your Supply Chain with WIN SOURCE Solutions

-  Global Sourcing Solution
-  Obsolete Management
-  Cost Control Management
-  Shortage Management
-  Alternative Solution
-  Excess Inventory Management