



# THE DATASHEET OF LP5520TLX



# LP5520 RGB Backlight LED Driver

## 1 Features

- Temperature Compensated LED Intensity and Color
- Individual Calibration Coefficients for Each Color
- Color Accuracy  $\Delta X$  and  $\Delta Y \leq 0.003$
- 12-Bit ADC for Measurement of 2 Sensors
- Adjustable Current Outputs for Red, Green, and Blue (RGB) LED
- 0.2% Typical LED Output Current Matching
- PWM Control Inputs for Each Color
- SPI™ and I<sup>2</sup>C-Compatible Interface
- Stand-Alone Mode With One-Wire Control
- Sequential Mode for One Color at a Time
- Magnetic High Efficiency Boost Converter
- Programmable Output Voltage from 5 V to 20 V
- Adaptive Output Voltage Control Option
- < 2- $\mu$ A Typical Shutdown Current

## 2 Applications

- Color LCD Display Backlighting
- LED Lighting Applications

## 3 Description

The LP5520 is an RGB backlight LED driver for small format color LCDs. RGB backlights enable better colors on the display and power savings compared with white LED backlights. The device offers a small and simple driver solution without need for optical feedback. Calibration in display module production can be done in one temperature. The LP5520 produces true white light over a wide temperature range. Three independent LED drivers have accurate programmable current sinks and PWM modulation control. Using internal calibration memory and external temperature sensor, the RGB LED currents are adjusted for perfect white balance independent of the brightness setting or temperature. The user programmable calibration memory has intensity vs temperature data for each color. This white balance calibration data can be programmed to the memory on the production line of a backlight module.

The device has a magnetic boost converter that creates a supply voltage of up to 20 V LED from the battery voltage. The output can be set at 1-V steps from 5 V to 20 V. In adaptive mode the circuit automatically adjusts the output voltage to minimum sufficient level for lowest power consumption. Temperature is measured using an external temperature sensor placed close to the LEDs. The second ADC input can be used, for example, for ambient light measurement.

### Device Information<sup>(1)</sup>

PART NUMBER	PACKAGE	BODY SIZE (MAX)
LP5520	DSBGA (25)	2.787 mm x 2.621 mm

(1) For all available packages, see the orderable addendum at the end of the data sheet.

### Typical Application

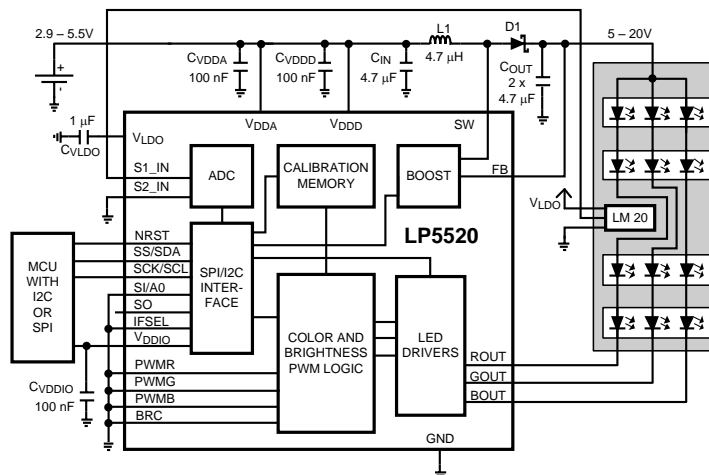

## Table of Contents

<b>1 Features</b> ..... 1 <b>2 Applications</b> ..... 1 <b>3 Description</b> ..... 1 <b>4 Revision History</b> ..... 2 <b>5 Pin Configuration and Function</b> ..... 3 <b>6 Specifications</b> ..... 4 6.1 Absolute Maximum Ratings ..... 4 6.2 ESD Ratings..... 4 6.3 Recommended Operating Conditions ..... 4 6.4 Thermal Information ..... 4 6.5 Electrical Characteristics..... 5 6.6 RGB Driver Electrical Characteristics (ROUT, GOUT, BOUT Outputs) ..... 5 6.7 Logic Interface Characteristics..... 6 6.8 Magnetic Boost DC-DC Converter Electrical Characteristics ..... 6 6.9 I <sup>2</sup> C Timing Parameters ..... 7 6.10 SPI Timing Requirements ..... 7 6.11 Typical Characteristics ..... 8 <b>7 Detailed Description</b> ..... 9 7.1 Overview ..... 9	7.2 Functional Block Diagram ..... 9 7.3 Feature Description..... 9 7.4 Device Functional Modes..... 18 7.5 Programming..... 22 7.6 Register Maps ..... 28 <b>8 Application and Implementation</b> ..... 33 8.1 Application Information..... 33 8.2 Typical Applications ..... 33 <b>9 Power Supply Recommendations</b> ..... 37 <b>10 Layout</b> ..... 37 10.1 Layout Guidelines ..... 37 10.2 Layout Example ..... 38 <b>11 Device and Documentation Support</b> ..... 39 11.1 Device Support..... 39 11.2 Documentation Support ..... 39 11.3 Community Resources..... 39 11.4 Trademarks ..... 39 11.5 Electrostatic Discharge Caution ..... 39 11.6 Glossary ..... 39 <b>12 Mechanical, Packaging, and Orderable Information</b> ..... 40
---	---

## 4 Revision History

NOTE: Page numbers for previous revisions may differ from page numbers in the current version.

Changes from Revision A (May 2013) to Revision B	Page
• Changed "R, G and B" to "Red, Green, and Blue" .....	1
• Deleted "Non-Linear Temperature Compensation" and "Ambient Light Compensation" from Applications .....	1
• Added <i>Device Information</i> and <i>Pin Configuration and Functions</i> sections, <i>ESD Ratings</i> and <i>Thermal Information</i> tables, <i>Feature Description</i> , <i>Device Functional Modes</i> , <i>Application and Implementation</i> , <i>Power Supply Recommendations</i> , <i>Layout</i> , <i>Device and Documentation Support</i> , and <i>Mechanical, Packaging, and Orderable Information</i> sections.....	1
• Changed "MAIN, SUB" to " ROUT, GOUT, BOUT".....	4
• Changed "come" to "are loaded" .....	12
• Changed ", and also the variable" to ". The variable parameter".....	18
• Changed "makes possible" to "allows".....	19
• Changed "read" to "loaded".....	19
• Changed "The stand-alone mode must be inhibited in automatic and manual modes by writing the control bit <brc_off> high and by keeping BRC input low." to new text .....	19

Changes from Original (April 2013) to Revision A	Page
• Changed layout of National Data Sheet to TI format .....	32

## 5 Pin Configuration and Function

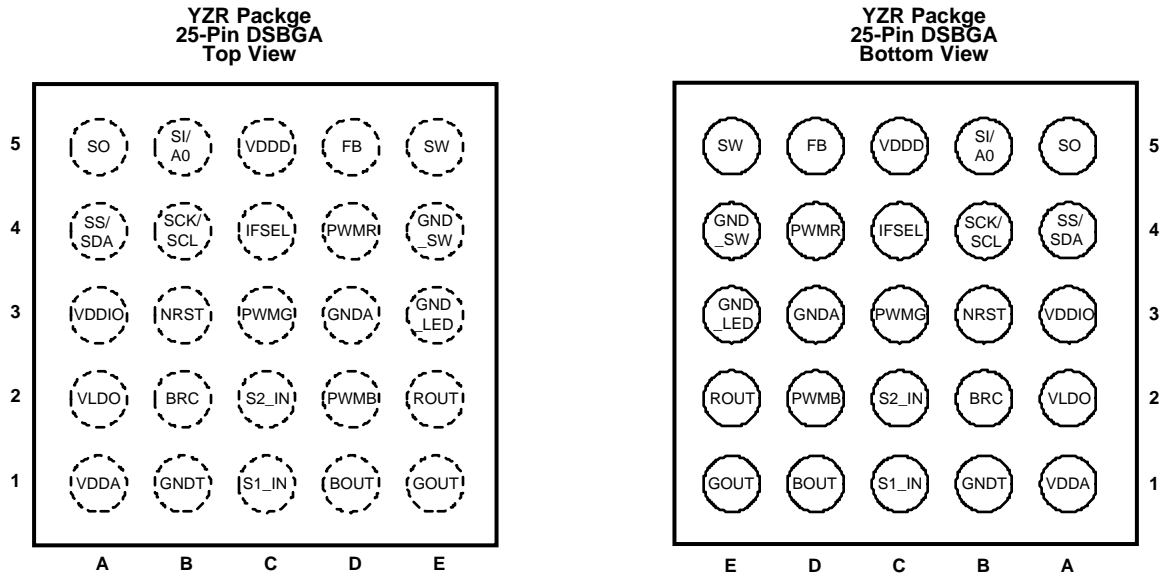

### Pin Functions

PIN		TYPE	DESCRIPTION
NUMBER	NAME		
1A	VDDA	Power	Supply voltage for analog circuitry
1B	GNDT	Ground	Ground/Test
1C	S1_IN	Input	ADC input 1, input for temperature sensor
1D	BOUT	Output	Blue LED output
1E	GOUT	Output	Green LED output
2A	VLDO	Power	Internal LDO output
2B	BRC	Logic Input	Brightness control for all LED outputs
2C	S2_IN	Input	ADC input 2, input for optional second sensor
2D	PWMB	Logic Input	PWM control for output B
2E	ROUT	Output	Red LED output
3A	VDDIO	Power	Supply voltage for input/output buffers and drivers
3B	NRST	Logic Input	Master reset, active low
3C	PWMG	Logic Input	PWM control for output G
3D	GNDA	Ground	Ground for analog circuitry
3E	GND_LED	Ground	Ground for LED currents
4A	SS/SDA	Logic Input/Output	Slave select (SPI), serial data in/out (I <sup>2</sup> C)
4B	SCK/SCL	Logic Input	Clock (SPI/I <sup>2</sup> C)
4C	IFSEL	Logic Input	Interface selection (SPI or I <sup>2</sup> C-compatible, IF_SEL = 1 for SPI)
4D	PWMR	Logic Input	PWM control for output R
4E	GND_SW	Ground	Power switch ground
5A	SO	Logic Output	Serial data out (SPI)
5B	SI/A0	Logic Input	Serial input (SPI), address select (I <sup>2</sup> C)
5C	VDDD	Power	Supply voltage for digital circuitry
5D	FB	Input	Boost converter feedback
5E	SW	Output	Boost converter power switch

## 6 Specifications

### 6.1 Absolute Maximum Ratings

over operating free-air temperature range (unless otherwise noted)<sup>(1)(2)(3)</sup>

	MIN	MAX	UNIT
V (SW, FB, ROUT, GOUT, BOUT)	-0.3	22	V
V <sub>DDA</sub> , V <sub>DDD</sub> , V <sub>DDIO</sub> , V <sub>LDO</sub>	-0.3	6	V
Voltage on logic pins	-0.3 V to V <sub>DDIO</sub>	0.3 V with 6 V maximum	V
Continuous power dissipation <sup>(4)</sup>	Internally limited		
Junction temperature, T <sub>J-MAX</sub>		125	°C
Storage temperature, T <sub>stg</sub>	-65	150	°C

- (1) Stresses beyond those listed under *Absolute Maximum Ratings* may cause permanent damage to the device. These are stress ratings only, which do not imply functional operation of the device at these or any other conditions beyond those indicated under *Recommended Operating Conditions*. Exposure to absolute-maximum-rated conditions for extended periods may affect device reliability.
- (2) All voltages are with respect to the potential at the GND pins.
- (3) If Military/Aerospace specified devices are required, contact the TI Sales Office/Distributors for availability and specifications.
- (4) Internal thermal shutdown circuitry protects the device from permanent damage. Thermal shutdown engages at T<sub>J</sub> = 160°C (typical) and disengages at T<sub>J</sub> = 140°C (typical).

### 6.2 ESD Ratings

		VALUE	UNIT
V <sub>(ESD)</sub> Electrostatic discharge	Human-body model (HBM), per ANSI/ESDA/JEDEC JS-001 <sup>(1)</sup>	±2000	V
	Charged-device model (CDM), per JEDEC specification JESD22-C101 <sup>(2)</sup>	±200	

- (1) JEDEC document JEP155 states that 500-V HBM allows safe manufacturing with a standard ESD control process.
- (2) JEDEC document JEP157 states that 250-V CDM allows safe manufacturing with a standard ESD control process.

### 6.3 Recommended Operating Conditions

over operating free-air temperature range (unless otherwise noted)<sup>(1)</sup>

	MIN	MAX	UNIT
V (SW, FB, ROUT, GOUT, BOUT)	0	21	V
V <sub>DDA,DDD</sub>	2.9	5.5	V
V <sub>DDIO</sub>	1.65	V <sub>DDA</sub>	V
Recommended load current (ROUT, GOUT, BOUT) per driver	0	60	mA
Junction temperature, T <sub>J</sub>	-30	125	°C
Ambient temperature, T <sub>A</sub> <sup>(2)</sup>	-30	85	°C

- (1) All voltages are with respect to the potential at the GND pins.
- (2) In applications where high power dissipation and/or poor package thermal resistance is present, the maximum ambient temperature may have to be derated. Maximum ambient temperature (T<sub>A-MAX</sub>) is dependent on the maximum operating junction temperature (T<sub>J-MAX-OP</sub> = 125°C), the maximum power dissipation of the device in the application (P<sub>D-MAX</sub>), and the junction-to ambient thermal resistance of the part/package in the application (R<sub>θJA</sub>), as given by the following equation: T<sub>A-MAX</sub> = T<sub>J-MAX-OP</sub> - (R<sub>θJA</sub> × P<sub>D-MAX</sub>).

### 6.4 Thermal Information

THERMAL METRIC <sup>(1)</sup>		LP5520	UNIT
		YZR (DSBGA)	
		25 PINS	
R <sub>θJA</sub>	Junction-to-ambient thermal resistance	58.2	°C/W
R <sub>θJC(top)</sub>	Junction-to-case (top) thermal resistance	0.3	°C/W
R <sub>θJB</sub>	Junction-to-board thermal resistance	7.9	°C/W
ψ <sub>JT</sub>	Junction-to-top characterization parameter	0.5	°C/W
ψ <sub>JB</sub>	Junction-to-board characterization parameter	7.9	°C/W

- (1) For more information about traditional and new thermal metrics, see the *Semiconductor and IC Package Thermal Metrics* application report, [SPRA953](#).

## 6.5 Electrical Characteristics

Unless otherwise noted typical limits are for  $T_J = 25^\circ\text{C}$ , minimum and maximum limits apply over the operating ambient temperature range ( $-30^\circ\text{C} < T_J < +85^\circ\text{C}$ ), and specifications apply to the LP5520 *Functional Block Diagram* with:  $C_{VDDA/D} = 100\text{ nF}$ ,  $C_{OUT} = 2 \times 4.7\text{ }\mu\text{F}$ ,  $25\text{ V}$ ,  $C_{IN} = 10\text{ }\mu\text{F}$ ,  $6.3\text{ V}$ ,  $L1 = 4.7\text{ }\mu\text{H}$ .<sup>(1)(2)(3)</sup>

PARAMETER		TEST CONDITIONS	MIN	TYP	MAX	UNIT
$I_{VDD}$	Standby supply current ( $V_{DDA} + V_{DDD}$ )	NSTBY = L, $V_{DDIO} \geq 1.65\text{ V}$		1.7	7	$\mu\text{A}$
		NSTBY = L, $V_{DDIO} = 0\text{ V}$		1		
	No-boost supply current ( $V_{DDA} + V_{DDD}$ )	NSTBY = H, EN_BOOST = L		0.9		mA
No-load supply current ( $V_{DDA} + V_{DDD}$ )	NSTBY = H, EN_BOOST = H AUTOLOAD = L		1.4			
$I_{VDDIO}$	$V_{DDIO}$ standby supply current	NSTBY = L			1	$\mu\text{A}$
$V_{LDO}$	Internal LDO output voltage	$V_{IN} \geq 2.9\text{ V}$ , $T_J = 25^\circ\text{C}$	2.77	2.80	2.84	V
$I_{LDO}$	Internal LDO output current	Current to external load			1	mA

- (1) All voltages are with respect to the potential at the GND pins.
- (2) Minimum and maximum limits are specified by design, test or statistical analysis. Typical numbers represent the most likely norm.
- (3) Low-ESR Surface-Mount Ceramic Capacitors (MLCCs) used in setting electrical characteristics.

## 6.6 RGB Driver Electrical Characteristics (ROUT, GOUT, BOUT Outputs)

Typical limits are for  $T_J = 25^\circ\text{C}$ , minimum and maximum limits apply over the operating ambient temperature range ( $-30^\circ\text{C} < T_J < +85^\circ\text{C}$ ); over operating free-air temperature range (unless otherwise noted).

PARAMETER		TEST CONDITIONS	MIN	TYP	MAX	UNIT
$I_{LEAKAGE}$	ROUT, GOUT, BOUT pin leakage current			0.1	1	$\mu\text{A}$
$I_{MAX}$	Maximum sink current	Outputs ROUT, GOUT, BOUT control = 255 (FFH)			60	mA
$I_R$	Current accuracy of ROUT, GOUT, and BOUT	Output current set to 20 mA	19	20	21	mA
			-5%		5%	
		Output current set to 60 mA	54	60	66	mA
			-10%		10%	
$I_{MATCH}$	Matching <sup>(1)</sup>	Between ROUT, GOUT, BOUT at 20 mA current		$\pm 0.2\%$	$\pm 2\%$	
$t_{PWM}$	PWM cycle time	Accuracy proportional to internal clock frequency		820		$\mu\text{s}$
$f_{RGB}$	RGB switching frequency	$\langle\text{pwm\_fast}\rangle = 0$		1.22		kHz
		$\langle\text{pwm\_fast}\rangle = 1$		19.52		
$V_{SAT}$	Saturation voltage <sup>(2)</sup>	$I_{(LED)} = 60\text{ mA}$		550		mV
$f_{MAX}$	External PWM maximum frequency	$I_{(LED)} = 60\text{ mA}$ , $T_J = 25^\circ\text{C}$			1	MHz

- (1) Matching is the maximum difference from the average when all outputs are set to same current.
- (2) Saturation voltage is defined as the voltage when the LED current has dropped 10% from the value measured at 2 V.

### 6.7 Logic Interface Characteristics

Typical limits are for  $T_J = 25^\circ\text{C}$ , minimum and maximum limits apply over the operating ambient temperature range ( $-30^\circ\text{C} < T_J < +85^\circ\text{C}$ ); over operating free-air temperature range (unless otherwise noted).

PARAMETER	TEST CONDITIONS	MIN	TYP	MAX	UNIT	
<b>LOGIC INPUTS SS, SI/A0, SCK/SCL, IFSEL, NRST, PWMR, PWMG, PWMB and BRC</b>						
$V_{IL}$	Input low level			$0.2 \times V_{DDIO}$	V	
$V_{IH}$	Input high level	$0.8 \times V_{DDIO}$			V	
$I_I$	Logic input current	-1		1	$\mu\text{A}$	
$f_{SCK/SCL}$	Clock frequency	$I^2C$ mode		0.4	MHz	
		SPI mode, $V_{DDIO} > 1.8\text{ V}$		13		
		SPI mode, $1.65\text{ V} < V_{DDIO} < 1.8\text{ V}$		5		
<b>LOGIC INPUT NRST</b>						
$V_{IL}$	Input low level			05	V	
$V_{IH}$	Input high level	1.2			V	
$I_I$	Logic input current	-1		1	$\mu\text{A}$	
$t_{NRST}$	Reset pulse width	10			$\mu\text{s}$	
<b>LOGIC OUTPUT SO</b>						
$V_{OL}$	Output low level	$I_{SO} = 3\text{ mA}$ $V_{DDIO} > 1.8\text{ V}$		0.3	0.5	V
		$I_{SO} = 2\text{ mA}$ $1.65\text{ V} < V_{DDIO} < 1.8\text{ V}$		0.3	0.5	V
$V_{OH}$	Output high level	$I_{SO} = -3\text{ mA}$ $V_{DDIO} > 1.8\text{ V}$	$V_{DDIO} - 0.5$	$V_{DDIO} - 0.3$		V
		$I_{SO} = -2\text{ mA}$ $1.65\text{ V} < V_{DDIO} < 1.8\text{ V}$	$V_{DDIO} - 0.5$	$V_{DDIO} - 0.3$		V
$I_L$	Output leakage current	$V_{SO} = 2.8\text{ V}$		1	$\mu\text{A}$	
<b>LOGIC OUTPUT SDA</b>						
$V_{OL}$	Output low level	$I_{SDA} = 3\text{ mA}$		0.3	0.5	V

### 6.8 Magnetic Boost DC-DC Converter Electrical Characteristics

Typical limits are for  $T_J = 25^\circ\text{C}$ , minimum and maximum limits apply over the operating ambient temperature range ( $-30^\circ\text{C} < T_J < +85^\circ\text{C}$ ); over operating free-air temperature range (unless otherwise noted).

PARAMETER	TEST CONDITIONS	MIN	TYP	MAX	UNIT
$I_{LOAD}$	Maximum continuous load current	$2.9\text{ V} = V_{IN}$ , $V_{OUT} = 20\text{ V}$ $T_J = 25^\circ\text{C}$	70		mA
$V_{OUT}$	Output voltage accuracy (FB pin)	$2.9 \leq V_{IN} \leq 5.5\text{ V}$ , $V_{OUT} = 20\text{ V}$ $T_J = 25^\circ\text{C}$	-1.7%		1.7%
		$2.9 \leq V_{IN} \leq 5.5\text{ V}$ , $V_{OUT} = 20\text{ V}$	-5%		5%
$R_{DS_{ON}}$	Switch ON resistance	$I_{SW} = 0.5\text{ A}$ $T_J = 25^\circ\text{C}$		0.3	$\Omega$
$f_{PWM}$	Frequency accuracy		-6%	$\pm 3\%$	6%
			-9%		9%
$t_{PULSE}$	Switch pulse minimum width	no load	50		ns
$t_{STARTUP}$	Start-up time		20		ms
$I_{MAX}$	SW pin current limit		1100		mA

### 6.9 I<sup>2</sup>C Timing Parameters

V<sub>DD1,2</sub> = 3 V to 4.5 V, V<sub>DDIO</sub> = 1.8 V To V<sub>DD1,2</sub>; see Figure 1.

		MIN	MAX	UNIT
1	Hold time (repeated) START condition	0.6		μs
2	Clock low time	1.3		μs
3	Clock high time	600		ns
4	Setup time for a repeated START condition	600		ns
5	Data hold time (output direction, delay generated by LP5520)	300	900	ns
5	Data hold time (input direction, delay generated by Master)	0	900	ns
6	Data setup time	100		ns
7	Rise time of SDA and SCL	20 + 0.1C <sub>b</sub>	300	ns
8	Fall time of SDA and SCL	15 + 0.1C <sub>b</sub>	300	ns
9	Setup time for STOP condition	600		ns
10	Bus free time between a STOP and a START condition	1.3		μs
C <sub>b</sub>	Capacitive load for each bus line	10	200	pF

### 6.10 SPI Timing Requirements

See Figure 2.

		MIN	MAX	UNIT
1	Cycle time	70		ns
2	Enable lead time	35		ns
3	Enable lag time	35		ns
4	Clock low time	35		ns
5	Clock high time	35		ns
6	Data setup time	0		ns
7	Data hold time	25		ns
8	Data access time		30	ns
9	Disable time		20	ns
10	Data valid		40	ns
11	Data hold time	0		ns

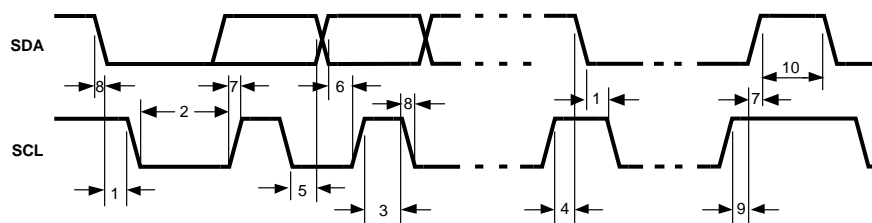

**Figure 1. I<sup>2</sup>C Timing Diagram**

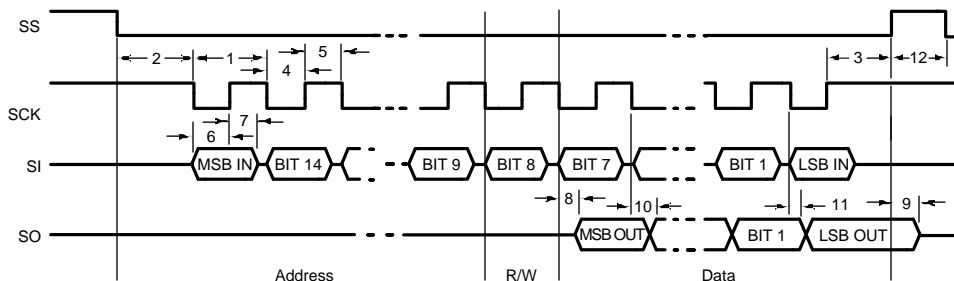

**Figure 2. SPI Timing Diagram**

## 6.11 Typical Characteristics

### 6.11.1 RGB Driver Typical Characteristics

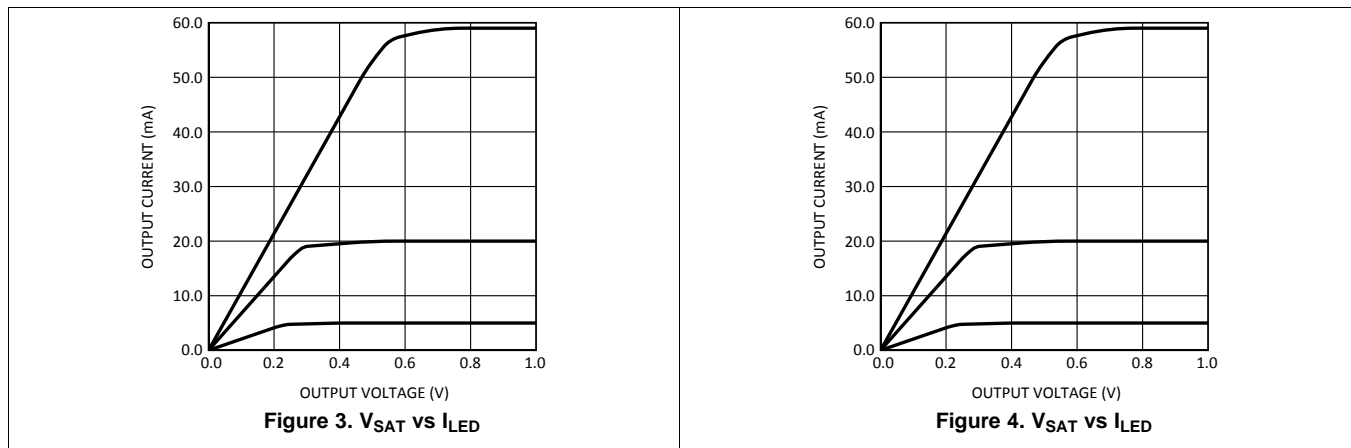

### 6.11.2 Boost Converter Typical Characteristics

$V_{IN} = 3.6\text{ V}$ ,  $V_{OUT} = 15\text{ V}$ , if not otherwise stated.

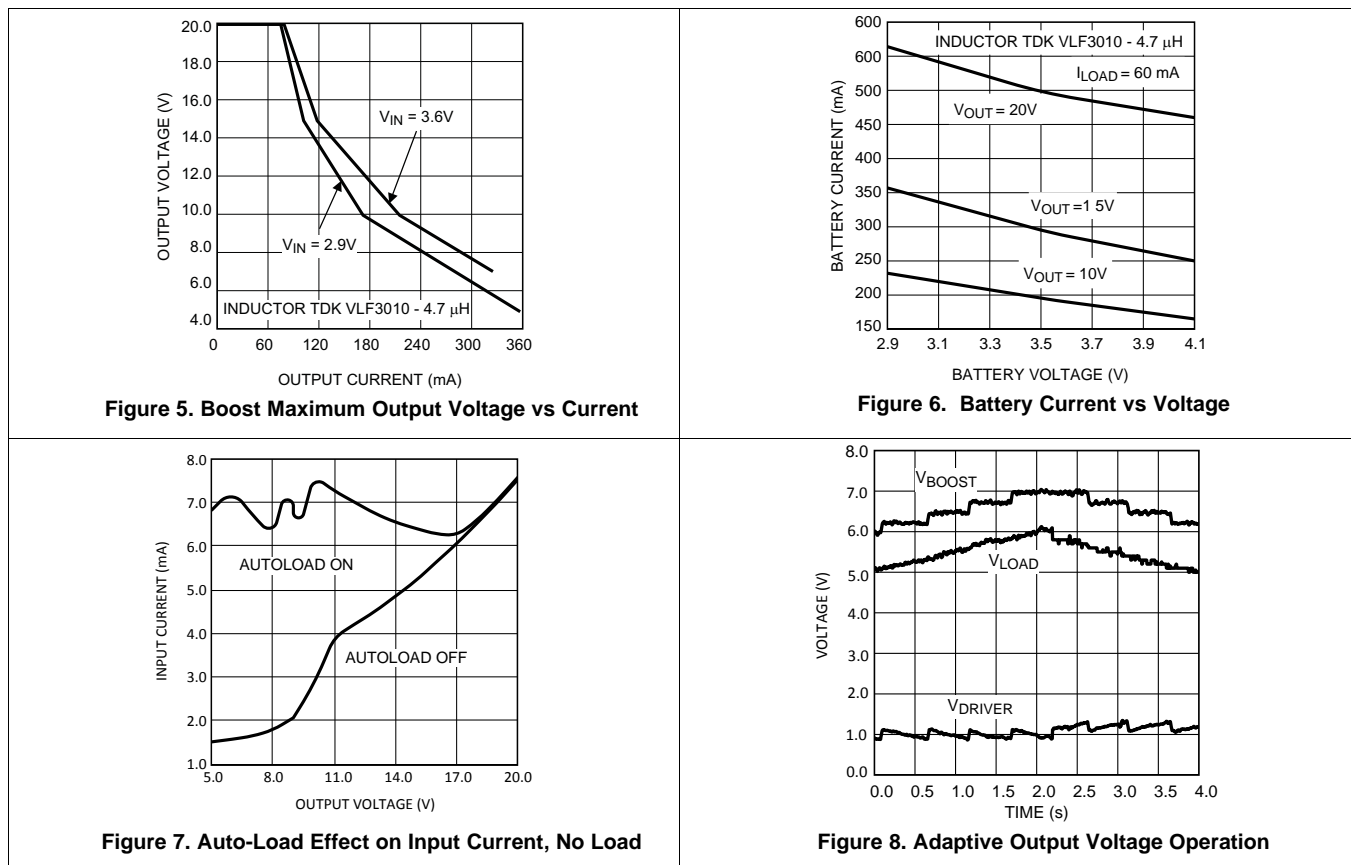

## 7 Detailed Description

### 7.1 Overview

The LP5520 is an RGB backlight LED driver for small format color LCDs. The LP5520 offers a small and simple driver solution without need for optical feedback. Calibration in display module production can be done in one temperature. The LP5520 produces true white light over a wide temperature range.

Three independent LED drivers have accurate programmable current sinks with up to 60 mA current capability and PWM modulation control. Using internal calibration memory and external temperature sensor, the RGB LED currents are adjusted for perfect white balance independent of the brightness setting or temperature. The user programmable calibration memory has intensity vs temperature data for each color. This white balance calibration data can be programmed to the memory on the production line of a backlight module.

The LP5520 has a magnetic boost converter that creates supply voltage up to 20-V LED from the battery voltage. The output can be set at 1-V step from 5 V to 20 V. In adaptive mode the circuit automatically adjusts the output voltage to minimum sufficient level for lowest power consumption.

Temperature is measured using an external temperature sensor placed close to the LEDs. The second ADC input can be used, for example, for ambient light measurement.

### 7.2 Functional Block Diagram

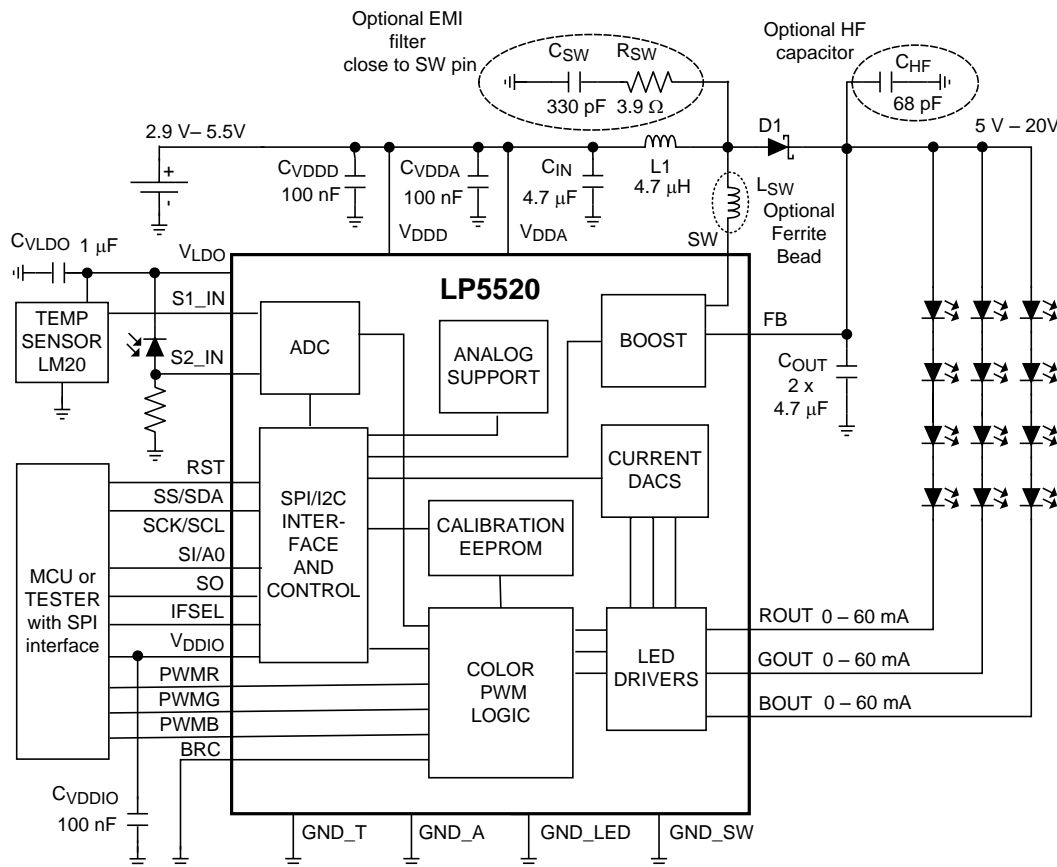

### 7.3 Feature Description

#### 7.3.1 Start-Up Powering

$V_{DDDD}$  and  $V_{DDA}$  must be tied together and turned on first.  $V_{DDIO}$  must be turned on at the same time as  $V_{DDDD}$  or later. In the power-off sequence  $V_{DDIO}$  must be turned off before  $V_{DDDD}$  or at the same time.

## Feature Description (continued)

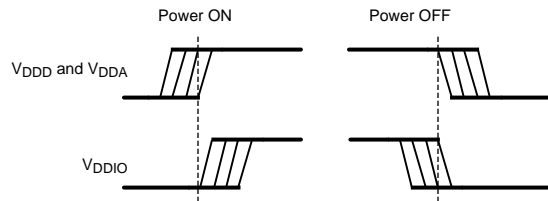

Figure 9. Power-On Signal Timing

### 7.3.2 RGB Driver Functionality

#### 7.3.2.1 White Balance Control

The LP5520 is designed to provide spectrally rich white light using a three-color RGB LED. White light is obtained when the red, green, and blue LED intensities are in proper balance. The LED intensities change independently with temperature. For maintaining the purity of the white color and the targeted total intensity, precise temperature dependent intensity control for each LED is required. The color coordinates in this document refer to the CIE 1931 color graph (x,y system).

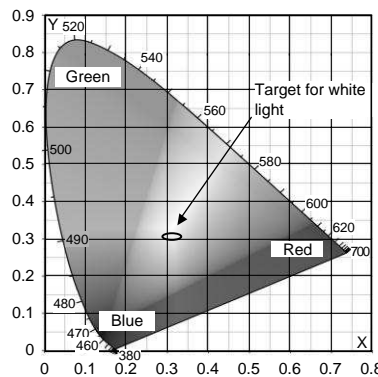

Figure 10. CIE 1931 Color Graph

Figure 11 shows a typical RGB LED intensity behavior on a 12-bit scale (0 to 4095) at constant 20-mA LED currents. Figure 12 shows the typical color coordinate change for an uncompensated RGB LED. Figure 13 shows the corresponding PWM values for achieving constant intensity white light across the temperature range. The PWM values have been saturated at 104°C to avoid overheating the LED and to better utilize the PWM range. The white balance is not maintained above 104°C in this case.

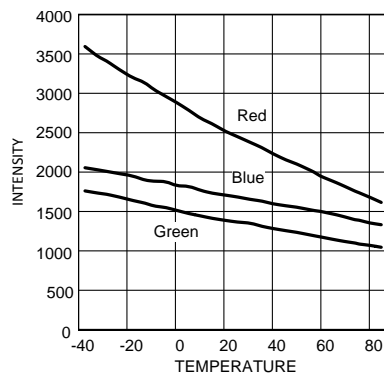

Figure 11. LED Intensity vs Temperature

Feature Description (continued)

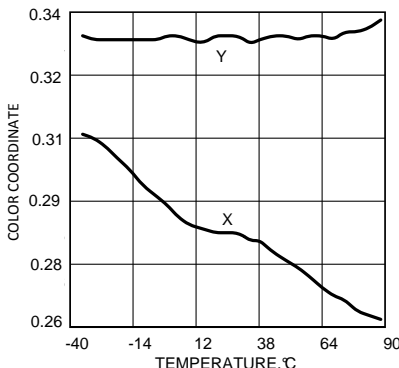

Figure 12. Typical Color Coordinates vs Temperature for Uncompensated RGB LED

The compensation values for the measured temperatures can be easily calculated when the intensity vs temperature information is available. For the best accuracy the iterative calibration approach must be used.

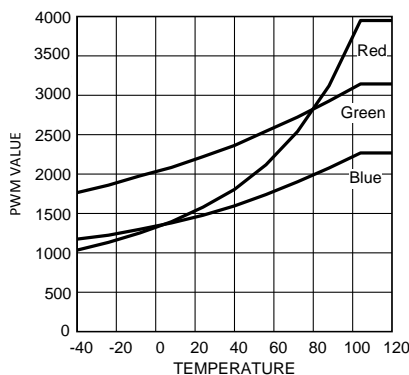

Figure 13. Compensation PWM Values

The compensation values must be converted to 16°C intervals when they are programmed to the calibration EEPROM. The evaluation software has import function, which can be used to convert the measured compensation data to the 16°C interval format. The measured data can have any temperature points, and the software fits a curve through the measured points and calculate new PWM values in fixed temperatures using the curves.

Typical color coordinate and intensity stability over temperature are shown in Figure 14 and Figure 15.

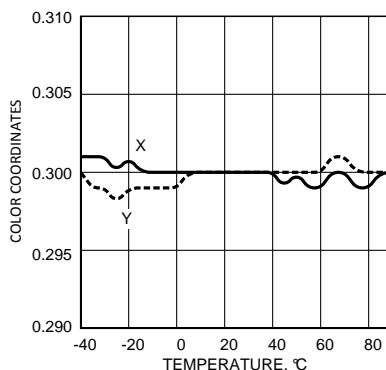
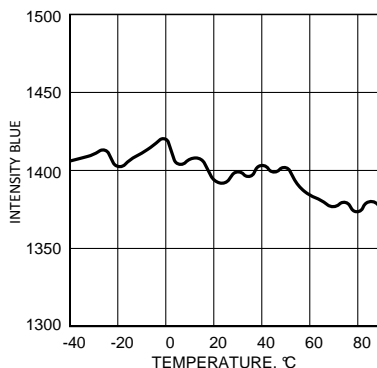

Figure 14. Compensated Color Coordinates vs Temperature

**Feature Description (continued)**



**Figure 15. Compensated Blue LED Intensity vs Temperature**

**7.3.2.2 LED Brightness Control**

The LED brightness is defined by two factors, the current through the LED and the PWM duty cycle. The constant current outputs ROUT, GOUT, and BOUT can be independently set to sink between 0 and 60 mA. The 8-bit current control has 255 levels, and the step size is 235  $\mu$ A. In manual mode the current is defined with the current control (R/G/B) registers (01H, 02H, and 03H). In automatic mode the current settings are loaded from the EEPROM.

The PWM control has 12-bit resolution, which means 4095 steps. The minimum pulse width is 200 ns, and the frequency can be set to either 1.2 kHz or 19.2 kHz. The duty cycle range is from 0 to 100% (0 to 4095). The output PWM value is obtained by multiplication of three factors. The first factor is the temperature-based value from the EEPROM. The second factor is the correction register setting, which is independent for each color. The third factor is the brightness register setting, which is common to all colors.

The temperature-based PWM values are stored in the EEPROM at 16°C intervals starting from –40°C and ending to 120°C. PWM values for the temperatures between the stored points are interpolated.

LED brightness has 3-bit logarithmic control. The control bits are in the pwm\_brightness (04H) register. The 3-bit value defines a multiplier for the 12-bit PWM value obtained from the memory according to [Table 1](#).

Feature Description (continued)

Table 1. PWM Value Multipliers

CONTROL BYTE <bri[2:0]> <sup>(1)</sup>	MULTIPLIER	INTENSITY ( %)
0	0.008	0.8
1	0.016	1.6
2	0.031	3.1
3	0.063	6.3
4	0.125	12.5
5	0.250	25
6	0.500	50
7	1.000	100

(1) PWM Brightness register control

The brightness correction can be used for aging compensation or other fine-tuning. There is an 8-bit correction register for each output. The PWM value obtained from the memory is multiplied by the correction value. The default correction value is 1. Correction range is from 0 to 2 and the LSB is 0.78% (1/128).

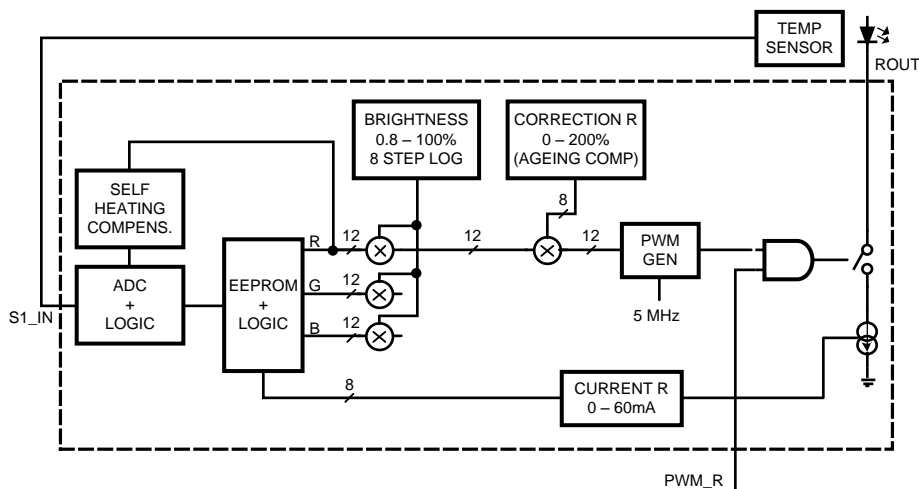

Shown complete only for red channel

Figure 16. LED Control Principle

7.3.2.3 LED PWM Control

The PWM frequency can be selected of two alternatives, slow and fast, with the control bit <pwm\_fast>. The slow frequency is 1.2 kHz. In the fast mode the PWM frequency is multiplied by 16, and the frequency is 19.2 kHz. Fast mode is the default mode after reset. The single pulse in normal PWM is split in 16 narrow pulses in fast PWM. Higher frequency helps eliminate possible noise from the ceramic capacitors and it also reduces the ripple in the boost voltage. Minimum pulse length is 200 ns in both modes.

The PWM pulses of each output do not start simultaneously in order to avoid high current spike. Red starts in the beginning of the PWM cycle, Green is symmetric with the cycle center and Blue ends in the end of the cycle. For PWM values less than 33% for each output, the output currents are completely non-overlapping. With higher PWM values the overlapping increases.

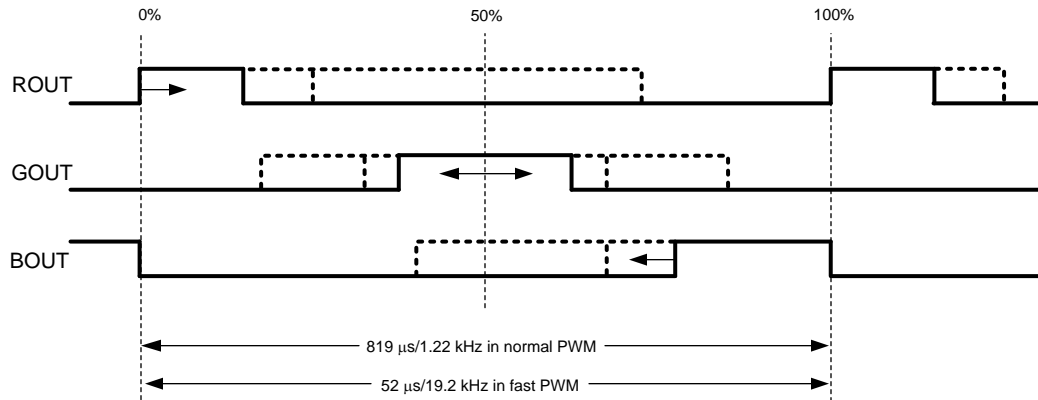

Figure 17. Pulse Positions in the PWM Cycle

### 7.3.2.4 Sequential Mode

Completely non-overlapping timing can be obtained by using the sequential mode as shown in Figure 18. The timing is defined with external PWM control inputs. The minimum trigger pulse width in the PWM inputs is 1 μs. There is no limitation on the maximum width of the pulse as long as it is shorter than the whole sequence.

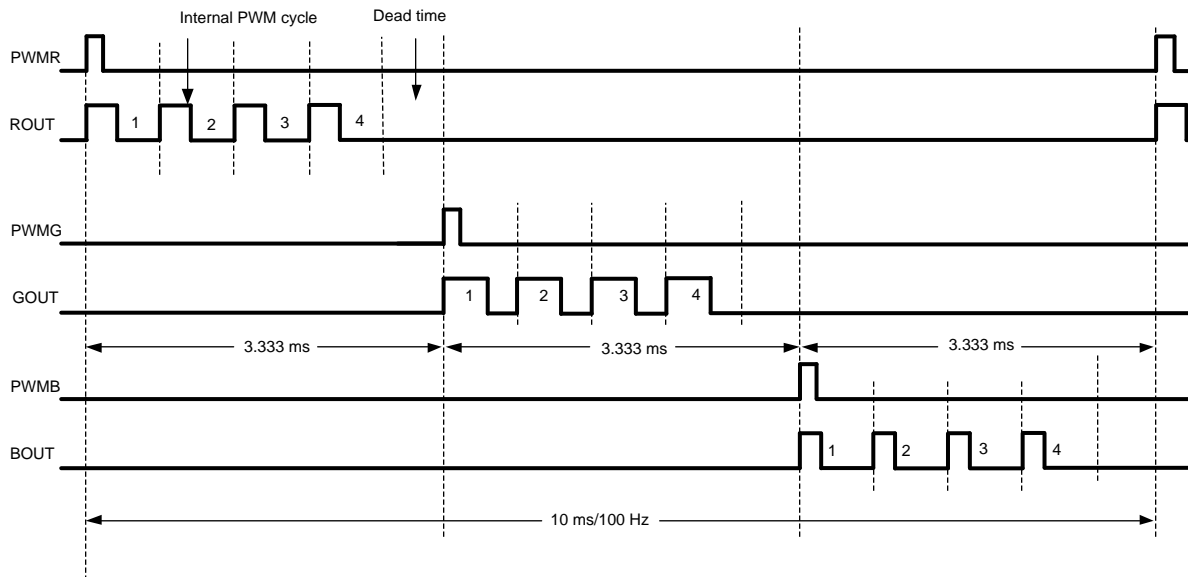

Figure 18. Non-Overlapping External Synchronized Sequential Mode

In sequential mode the PWM cycle is synchronized to trigger pulses and the amount of PWM pulses per trigger can be defined to 2, 3 or 4 using the `<seq_mode0>` and `<seq_mode1>` control bits. This makes possible to use sequence lengths of about 5 ms, 7.5 ms or 10 ms. Fast PWM can be used in sequential mode, but the frame timing is as with normal PWM.

The PWM timing and synchronization timing originate from different clock sources. Some margin must be allowed for clock tolerances. This margin shows as a dead time in the waveform graph. Some dead time must be allowed so that no PWM pulse is clipped. Clipping would distort the intensity balance between the LEDs. The dead time causes some intensity reduction, but assures the current balance.

PWM mode is defined by `<seq_mode1>` and `<seq_mode2>` control bits of `rgb_control` (00H) register:

**Table 2. PWM Mode**

<seq_mode1> (BIT 7)	<seq_mode0> (BIT 6)	MODE
0	0	Normal mode
0	1	Sequential mode with 2 PWM pulses per trigger
1	0	Sequential mode with 3 PWM pulses per trigger
1	1	Sequential mode with 4 PWM pulses per trigger

### 7.3.2.5 Current Control of the LEDs

The LP5520 has a separate 8-bit current control for each LED output. In manual mode the current for red LED is controlled with the **current\_control\_r** (01H) register, the green LED is controlled with the **current\_control\_g** (02H), and the blue LED with **current\_control\_b** (03H). Output current can be calculated with formula:  $current (mA) = code \times 0.235$ ; for example, a 20-mA current is obtained with code 85 (55H).

In automatic and stand-alone modes the LED current values programmed in EEPROM are used, and the current control registers have no effect. There are two ways to change the default current if needed. The defaults can be changed permanently by programming new values to the EEPROM. The other option is to make a temporary change by writing new current values in SRAM.

### 7.3.2.6 Output Enables

ROUT, GOUT, and BOUT output activity is controlled with 3 enable bits of the **rgb\_control** (00H) register:

**Table 3. Output Enable Bits**

<en_b> (bit 2)	0	Blue LED output BOUT disabled
	1	Blue LED output BOUT enabled
<en_g> (bit 1)	0	Green LED output GOUT disabled
	1	Green LED output GOUT enabled
<en_r> (bit 0)	0	Red LED output ROUT disabled
	1	Red LED output ROUT enabled

PWM control inputs PWMR, PWMG and PWMB can be used as external output enables in normal and automatic mode. In the sequential mode these inputs are the trigger inputs for respective outputs.

### 7.3.2.7 Fade In and Fade Out

The LP5520 has an automatic fade in and out for the LED outputs. Fading makes the transitions smooth in on and off switching or when brightness is changed. It is not applied for the changes caused by the compensation algorithm. The fade can be turned on and off using the **<en\_fade>** bit in the **rgb\_control** (00H) register. The fade time is constant 520 ms, and it does not depend on how big the brightness change is. The white balance is maintained during fading. Fading is off in the stand-alone mode.

**Table 4. Fade In and Fade Out With <en\_fade> Bit**

<en_fade>(bit 5)	0	Automatic fade disabled
	1	Automatic fade enabled

Fading only works in automatic mode. The LED current registers must be written to 0 for proper fade operation. When the LEDs are turned on with fading, it is best to set the brightness first and then enable the outputs and automatic mode. The LEDs can be turned off then by turning off the automatic mode (write `rgb_auto` to 0).

### 7.3.2.8 Temperature and Light Measurement

The LP5520 has a 12-bit analog-to-digital converter (ADC) for the measurements. The ADC has two inputs. S1\_IN input is intended for the LM20 temperature sensor and S2\_IN input for light measurement or any DC voltage measurement. The conversion results are filtered with average filter for 134 ms. The `<adc_ch>` bit in the **Control** register selects, which conversion result can be read out from the registers **ADC\_hi\_byte** and **ADC\_low\_byte**. The **ADC\_hi\_byte** must be read first. The `<comp_ch>` bit selects, which input is used for compensation. The ADC uses the LDO voltage 2.8 V as the reference voltage. The input signal range is 0 V to 2.8 V, and the inputs are buffered on the chip.

If S2\_IN is used for light measurement using TDK optical sensor BCS2015G1 as shown in the [Functional Block Diagram](#), the measurement range is from 10 to 20 000 lux when using a 100-kΩ resistor.

**Table 5. ADC Configuration**

<b>adc_ch(bit5)</b>	<b>0</b>	S1 input can be read
	<b>1</b>	S2 input can be read
<b>comp_sel(bit4)</b>	<b>0</b>	S1 input is used for compensation
	<b>1</b>	S2 input is used for compensation

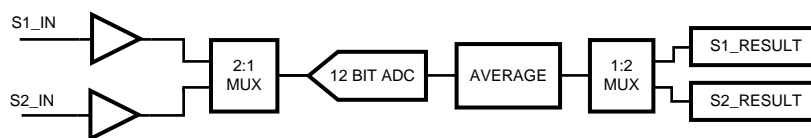

**Figure 19. ADC Operation Block Diagram**

### 7.3.3 Magnetic High-Voltage Boost DC-DC Converter

The LP5520 boost DC-DC converter generates a 5-V to 20-V supply voltage for the LEDs from single Li-Ion battery (2.9 V to 4.5V). The output voltage is controlled with four bits in 18 steps. In adaptive mode the output voltage is automatically adjusted so that the LED drivers have enough voltage for proper operation. The converter is a magnetic switching PWM mode DC-DC converter with a current limit. Switching frequency is 1 MHz. Boost converter options are controlled with few bits of Control (06H) register.

**Table 6. Boost DC-DC Converter Control**

<b>&lt;en_autoload&gt; (bit 3)</b>	<b>0</b>	Internal boost converter loader off
	<b>1</b>	Internal boost converter loader on
<b>&lt;vout_auto&gt; (bit 2)</b>	<b>0</b>	Manual boost output adjustment
	<b>1</b>	Adaptive boost output adjustment
<b>&lt;en_boost&gt; (bit 1)</b>	<b>0</b>	Boost converter standby mode
	<b>1</b>	Boost converter active mode
<b>&lt;nstby&gt; (bit 0)</b>	<b>0</b>	LP5520 standby mode
	<b>1</b>	LP5520 active mode

The LP5520 boost converter uses pulse-skipping elimination to stabilize the noise spectrum. Even with light load or no load a minimum length current pulse is fed to the inductor. An active load is used to remove the excess charge from the output capacitor at very light loads. Active load can be disabled with the `<en_autoload>` bit. Disabling active load increases slightly the efficiency at light loads, but the downside is that pulse skipping occurs. The boost converter must be stopped when there is no load to minimize the current consumption.

The topology of the magnetic boost converter is called current programmed mode (CPM) control, where the inductor current is measured and controlled with the feedback. The user can program the output voltage of the boost converter. The output voltage control changes the resistor divider in the feedback loop.

Figure 20 shows the boost topology with the protection circuitry. Four different protection schemes are implemented:

1. Overvoltage protection: limits the maximum output voltage and:
  - Keeps the output below breakdown voltage.
  - Prevents boost operation if battery voltage is much higher than desired output.
2. Overcurrent protection: limits the maximum inductor current and:
  - Voltage over switching NMOS is monitored; voltages too high turn off the switch.
3. Feedback break protection: prevents uncontrolled operation if FB pin is disconnected.
4. Duty cycle limiting done with digital control.

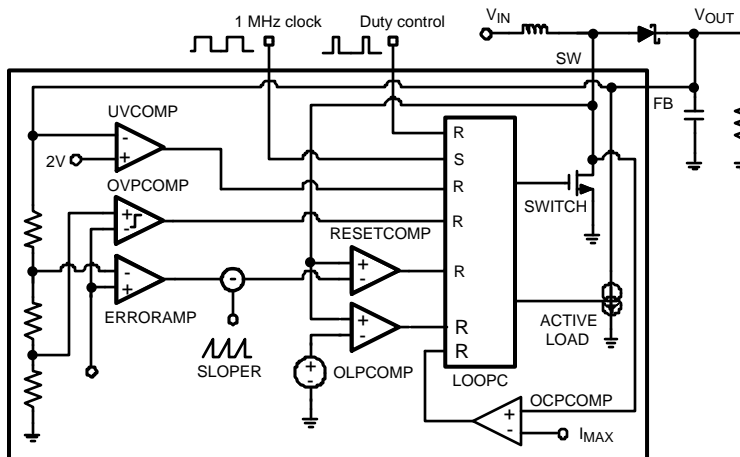

Figure 20. Boost Converter Topology

### 7.3.3.1 Boost Control

User can set the boost converter to standby mode by writing the register bit `<en_boost>` low. When `<en_boost>` is written high, the converter starts for 50 ms in low current PWM mode and then goes to normal PWM mode.

User can control the boost output voltage by boost output `boost_output` (05H) register.

Table 7. Boost Output Voltage Control

BOOST OUTPUT [7:0] REGISTER 0DH		BOOST OUTPUT VOLTAGE (TYPICAL)
Bin	Dec	
00101	5	5 V
00110	6	6 V
00111	7	7 V
...	...	...
01100	12	12 V
01101	13	13 V
01110	14	14 V
...	...	...
10010	18	18 V
10011	19	19 V
10100	20	20 V

If register value is lower than 5, then value of 5 is used internally. If register value is higher than 20, then value of 20 is used internally.

### 7.3.3.2 Adaptive Output Voltage Control

When automatic boost voltage control is selected using the **<vout\_auto>** bit in the **Control** (06H) register, the user-defined boost output voltage is ignored. The boost output voltage is adjusted for sufficient operating headroom by monitoring all enabled LED driver outputs. The boosted voltage is adjusted so that the lowest driver voltage is from 0.85 V to 1.35 V when the LED output currents are below 30 mA and from 1 V to 1.5V when any LED current is above 30 mA. The output voltage range is from 5 V to 20 V in adaptive mode.

The adaptive voltage control helps saving energy by always setting the boost voltage to minimum sufficient value. It eliminates the need for extra voltage margins due to LED forward voltage variation or temperature variation. With very small brightness settings, when the PWM pulses in LED outputs are very narrow, the adaptive voltage setting gives higher than necessary boost voltage. This does not harm the overall efficiency, because this happens only at low power levels.

After reset the adaptive control is on by default. In stand-alone mode the adaptive output voltage is always used.

## 7.4 Device Functional Modes

The LP5520 has three different operating modes: manual mode, automatic mode, and stand-alone mode. Automatic mode has two sub modes: normal mode and sequential mode. In manual and automatic modes the device is controlled through the serial interface. In stand-alone mode only BRC input must be controlled, and all registers have the default values. The modes are controlled according [Table 8](#).

**Table 8. Device Operating Modes Control**

<b>&lt;RGB_auto&gt; (RBG control bit 3)</b>	<b>&lt;seq_mode[0:1]&gt; (RBG control bits 6 and 7)</b>	<b>DEVICE OPERATING MODE</b>
<b>0</b>	<b>00</b>	Manual mode
<b>1</b>	<b>00</b>	Automatic mode, normal operation (overlapping)
<b>1</b>	<b>01, 10, or 11</b>	Automatic mode, sequential operation with 2, 3, or 4 pulses per sequence

### 7.4.1 Manual Mode

In the manual mode the automatic LED intensity adjustment is not in use. The internal PWM control is disabled, and the LEDs are driven with DC current. The user can set the LED currents through the serial port using three current control registers, *current\_control\_R/G/B*, and use the external PWM control inputs to adjust LED intensities if needed. There is an independent PWM control pin for each output. If PWM control is not used, the PWMR, PWMG, and PWRM inputs must be tied to the  $V_{DDIO}$ . All the functions implemented with the internal PWM control are unavailable in manual mode (logarithmic brightness control from PWM Control register, temperature compensation, fading, sequential mode).

### 7.4.2 Automatic Mode

In the automatic mode the LED intensities are controlled with the 12-bit PWM values obtained from the EEPROM memory according to the temperature information. PWM values are stored at 16°C intervals for the –40°C to +120°C temperature range, and the PWM values for the intermediate temperatures are linearly interpolated.

When creating white light from a RGB LED, the intention is to program PWM values, which keep the individual LED intensities constant in all temperatures. For possible other applications, other kind of PWM behavior can be programmed. The variable parameter can be other than temperature if the sensor is changed to, for example, a light sensor.

12-bit ADC is used for the measurements. The ADC has two inputs: S1\_IN and S2\_IN. The temperature measurement result from the S1\_IN input is converted to EEPROM address using the sensor calibration data from EEPROM. This EEPROM address is then used to get the PWM values for each output. The second input S2\_IN can be used for example for ambient light measurement. The ADC data from selected input can be read through the serial interface. Control bit **<comp\_sel>** can be used to select which input is used for compensation.

Current setting for each LED comes from EEPROM in the automatic mode. The same current values must be programmed as were used in the calibration. Current control range is from 0 to 60 mA with 8-bit resolution and the step size is 235  $\mu$ A.

Common brightness control for all LEDs can be done using the `pwm_brightness` (05H) register. The **pwm\_brightness register** makes 8 level logarithmic brightness control with 3 bits. An automatic fade function allows smooth turnon, turnoff, and brightness changes of the LEDs. White balance is maintained during fading.

A brightness correction value can be given for each LED. The PWM value obtained from the EEPROM memory is multiplied by this correction value. This feature can be used for example for LED aging compensation or for color adjustment by user. These values are kept in **R\_correction** (0AH), **G\_correction** (0BH) and **B\_correction** (0CH) registers. The correction multiplier can be between 0 and 2.

Due to LED self-heating, the temperature sensor and the LED temperatures will differ. The difference depends on the thermal structure of the display module and the distance between the sensor and the LEDs. This temperature difference can be compensated by storing the temperature difference value at highest power (100% red LED PWM) in the EEPROM memory. The system then corrects the measured temperature based on the actual PWM value used. The correction assumes that the red LED PWM value is representing the whole RGB LED power consumption.

Sequential (non-overlapping) drive is possible using external PWM control inputs to trigger a new sequence in each LED output. 60 mA maximum current setting makes possible 20 mA maximum averaged current for each output in the non-overlapping mode.

### 7.4.3 Stand-Alone Mode

In stand-alone mode the operation is controlled through a single PWM brightness input, BRC. After power-up or reset the LP5520 is ready for stand-alone operation without any setup through the serial interface. The stand-alone mode is entered with a rising edge in the BRC input. The boost converter operates in adaptive mode. The LED current settings are loaded from EEPROM. The LED brightness is controlled with a PWM signal in the BRC input. The BRC PWM frequency must be from 2 to 10 kHz. The PWM signal in the BRC input is not used as such for the LED outputs, but it is converted to 3-bit value and a logarithmic brightness control is based on this 3-bit value, as shown in [Table 9](#). There is hysteresis in the conversion to avoid blinking when the BRC duty cycle is close to a threshold. When the PWM pulses end in the BRC input and the input stays low, the circuit goes to the standby mode.

[Figure 21](#) shows the waveforms in BRC input and ROUT output in the stand-alone mode. The circuit is in standby mode until the first rising edge in BRC input is detected. The circuit starts up, and the outputs activate after 30 ms from the first rising edge in BRC. The BRC frequency is assumed to be 2 kHz in this example giving 0.5 ms BRC period. When the duty cycle changes in BRC, it takes two BRC periods before the change is reflected in the output. When BRC goes permanently low, the circuit enters standby mode after 15 ms from the last BRC pulse.

All controls through the serial interface can be used in the stand-alone mode. In Automatic and Manual mode the control bit `<brc_off>` must be written high and BRC input kept low to prevent the LP5520 device from entering stand-alone mode.

**Table 9. Stand-Alone Mode Brightness Control**

BRC DUTY CYCLE THRESHOLD VALUES (%)		INTENSITY (% of maximum)	RECOMMENDED BRC PWM CONTROL VALUES	
INCREASING	DECREASING		INCREASING	DECREASING
	0	off		0
1	15	0.8	10	10
20	28	1.6	28	22
35	42	3.1	40	32
48	52	6.3	53	47
58	62	12.5	63	58
68	75	25	75	70
82	90	50	88	85
97		100	99	

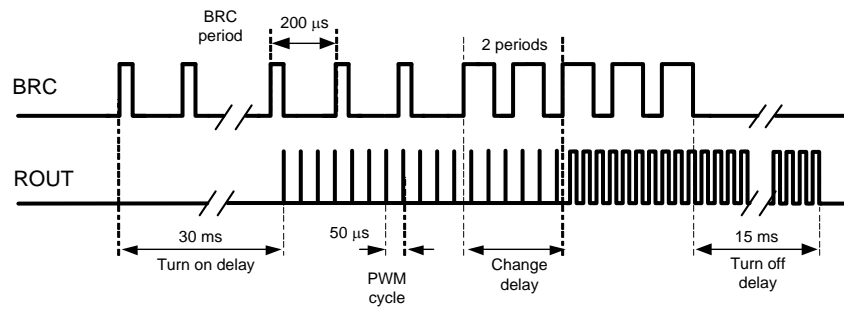

Figure 21. LP5520 Control and Output Waveforms in Stand-Alone Mode

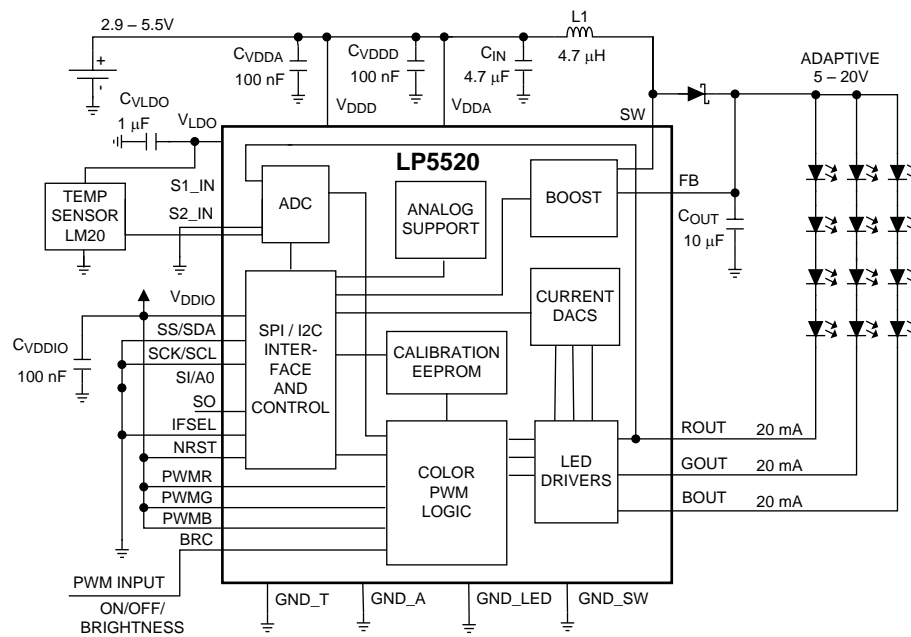

Figure 22. LP5520 Connections in Stand-Alone Mode

### 7.4.4 Start-Up Sequence

**RESET:** In the RESET mode all the internal registers are reset to the default values, and the chip goes to STANDBY mode after reset. <NSTBY> control bit is low after reset by default. Reset is entered always if NRST input is low or internal power on reset (POR) is active. POR activates during the chip start-up or when the supply voltage VDD falls below 1.5 V. Once VDD rises above 1.5 V, POR inactivates, and the device continues to the STANDBY mode.

**STANDBY:** The STANDBY mode is entered if the register bit <NSTBY> is LOW. This is the low-power consumption mode, when all circuit functions are disabled. Registers can be written in this mode, and the control bits are effective immediately after power up.

**STARTUP:** When <NSTBY> bit is written high or there is a rising edge in the BRC input, the INTERNAL STARTUP SEQUENCE powers up all the needed internal blocks (Vref, Bias, Oscillator, etc.). To ensure the correct initialization, a 10-ms delay is generated by the internal state-machine after the trim EEPROM values are read. If the chip temperature rises too high, the thermal shutdown (TSD) disables the chip operation, and STARTUP mode is entered until no TSD event is present.

**BOOST STARTUP:** Soft start for boost output is generated in the BOOST STARTUP mode. The boost output is raised in PWM mode during the 20-ms delay generated by the state machine. All LED outputs are off during the 20-ms delay to ensure smooth start-up. The boost start-up is entered from internal start-up sequence if <EN\_BOOST> is HIGH or from Normal mode when <EN\_BOOST> is written HIGH.

**NORMAL:** During NORMAL mode the user controls the chip using the control registers or the BRC input in stand-alone mode. The registers can be written in any sequence and any number of bits can be altered in a register in one write.

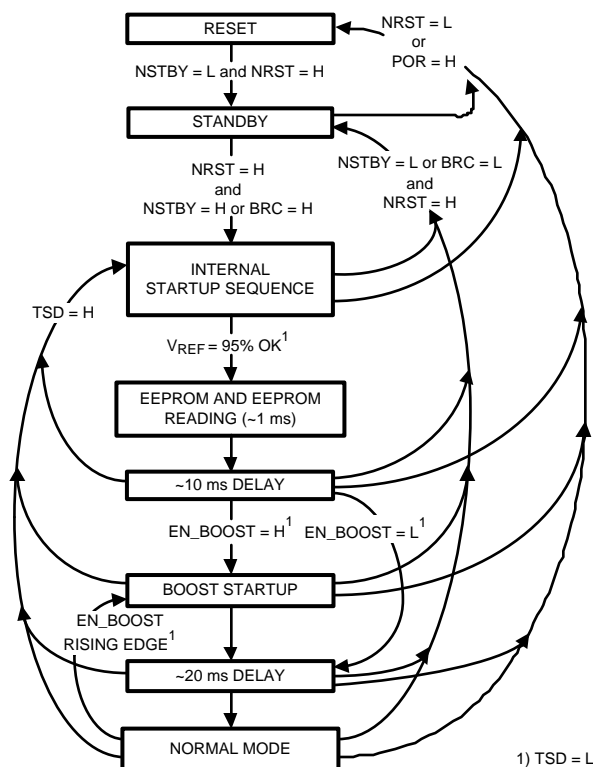

Figure 23. Device Functional Modes

## 7.5 Programming

### 7.5.1 Control Interface

The LP5520 supports two different interface modes:

- SPI interface (4-wire, serial), and
- I<sup>2</sup>C-compatible interface (2-wire, serial)

User can define the serial interface by IF\_SEL pin. IF\_SEL = 0 selects the I<sup>2</sup>C mode.

#### 7.5.1.1 I<sup>2</sup>C Compatible Interface

##### 7.5.1.1.1 I<sup>2</sup>C Signals

The serial interface is in I<sup>2</sup>C mode when IF\_SEL = 0. The SCL pin is used for the I<sup>2</sup>C clock and the SDA pin is used for bidirectional data transfer. Both these signals need a pullup resistor according to I<sup>2</sup>C specification. The values of the pullup resistors are determined by the capacitance of the bus (typical resistance is 1.8 kΩ). Signal timing specifications are shown in [I<sup>2</sup>C Timing Parameters](#).

##### 7.5.1.1.2 I<sup>2</sup>C Data Validity

The data on SDA line must be stable during the HIGH period of the clock signal (SCL). In other words, state of the data line can only be changed when CLK is LOW.

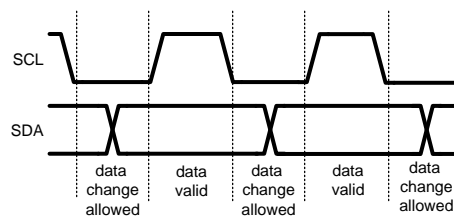

**Figure 24. I<sup>2</sup>C Signals: Data Validity**

##### 7.5.1.1.3 I<sup>2</sup>C Start and Stop Conditions

START and STOP bits classify the beginning and the end of the I<sup>2</sup>C session. START condition is defined as SDA signal transitioning from HIGH to LOW while SCL line is HIGH. STOP condition is defined as the SDA transitioning from LOW to HIGH while SCL is HIGH. The I<sup>2</sup>C master always generates START and STOP bits. The I<sup>2</sup>C bus is considered to be busy after START condition and free after STOP condition. During data transmission, I<sup>2</sup>C master can generate repeated START conditions. First START and repeated START conditions are equivalent, function-wise.

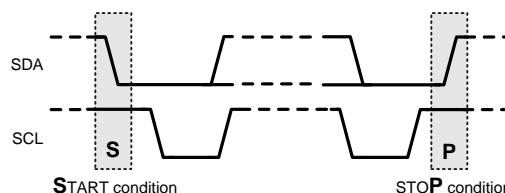

**Figure 25. I<sup>2</sup>C Start and Stop Conditions**

##### 7.5.1.1.4 Transferring Data

Every byte put on the SDA line must be eight bits long, with the most significant bit (MSB) being transferred first. Each byte of data has to be followed by an acknowledge bit. The acknowledge related clock pulse is generated by the master. The transmitter releases the SDA line (HIGH) during the acknowledge clock pulse. The receiver must pull down the SDA line during the 9<sup>th</sup> clock pulse, signifying an acknowledge. A receiver which has been addressed must generate an acknowledge after each byte has been received.

## Programming (continued)

After the START condition, the I<sup>2</sup>C master sends a chip address. This address is seven bits long followed by an eighth bit which is a data direction bit (R/W). The LP5520 address is 20h when SI=0 and 21h when SI=1. For the eighth bit, a 0 indicates a WRITE and a 1 indicates a READ. The second byte selects the register to which the data is written. The third byte contains data to write to the selected register.

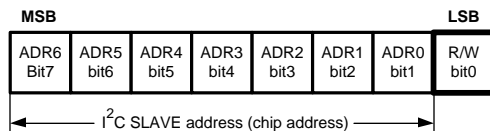
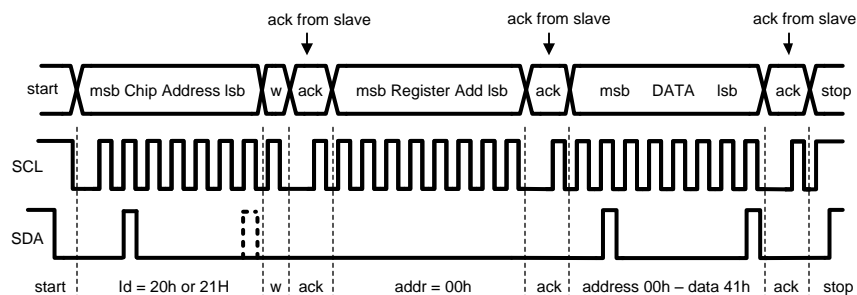

Figure 26. I<sup>2</sup>C Chip Address



w = write (SDA = 0)  
 r = read (SDA = 1)  
 ack = acknowledge (SDA pulled down by either master or slave)  
 rs = repeated start  
 id = 7-bit chip address, 20h when SI=0 and 21h when SI=1 for LP5520.

Figure 27. I<sup>2</sup>C Write Cycle

When a READ function is to be accomplished, a WRITE function must precede the READ function, as shown in the I<sup>2</sup>C Read Cycle waveform.

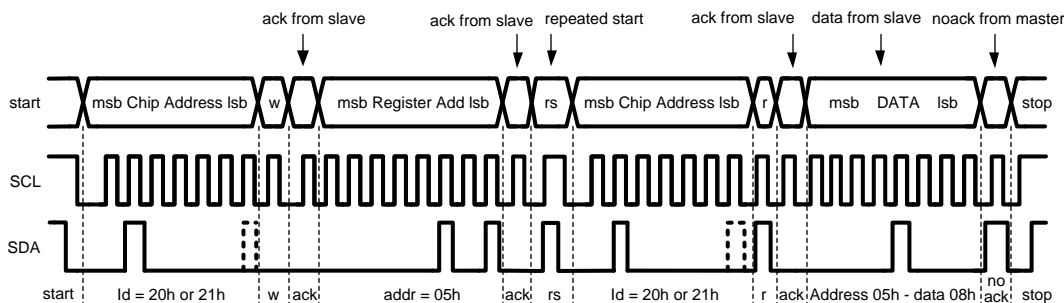
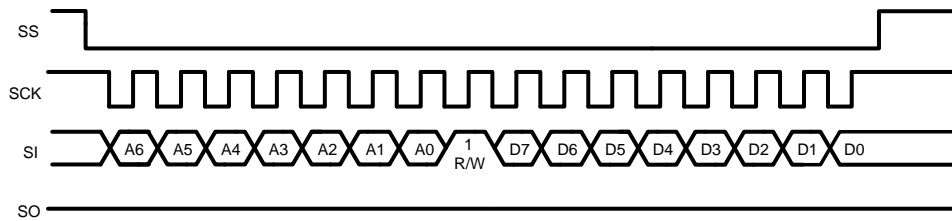

Figure 28. I<sup>2</sup>C Read Cycle

### 7.5.1.2 SPI Interface

The LP5520 is compatible with SPI serial-bus specification, and it operates as a slave. The transmission consists of 16-bit write and read cycles. One cycle consists of 7 address bits, 1 read/write (RW) bit, and 8 data bits. RW-bit high state defines a write cycle and low defines a read cycle. SO output is normally in high-impedance state, and it is active only when data is sent out during a read cycle. The address and data are transmitted MSB first. The slave select signal (SS) must be low during the cycle transmission. SS resets the interface when high, and it must be taken high between successive cycles. Data is clocked in on the rising edge of the SCK clock signal, while data is clocked out on the falling edge of SCK.

**Programming (continued)**



**Figure 29. SPI Write Cycle**

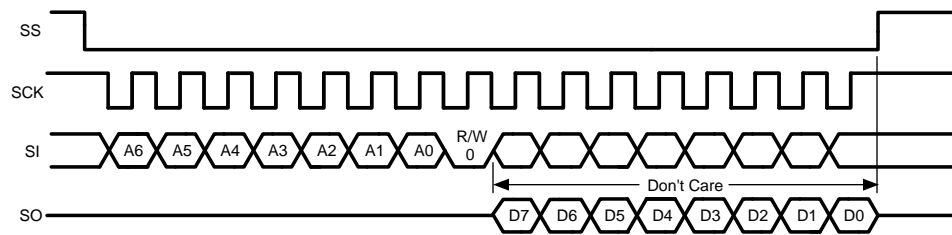

**Figure 30. SPI Read Cycle**

**7.5.1.2.1 SPI Incremental Addressing**

The LP5520 supports incremental addressing for memory read and write.

**7.5.2 EEPROM Memory**

The 1-kbit calibration EEPROM memory is organized as 128 x 8 bits. It stores the 12-bit calibration PWM values for each output at 16°C intervals. Ten temperature points are used to cover the range from –40 to +120°C. The temperature or light sensor calibration data, self-heating factor, and LED currents are also stored in the memory. The memory contents and detailed memory map are shown in [Table 10](#) and [Table 11](#).

**Table 10. EEPROM Contents**

DATA	LENGTH	TOTAL BITS
10 PWM values for red	12	120
10 coefficients for red between the points	8	80
10 PWM values for green	12	120
10 coefficients for green between the points	8	80
10 PWM values for blue	12	120
10 coefficients for blue between the points	8	80
0°C reading for temperature sensor	12	12
Coefficient for temperature sensor	12	12
Maximum self-heating (100% red PWM)	8	8
Default current for ROUT	8	8
Default current for GOUT	8	8
Default current for BOUT	8	8
Free memory for user data	8	368

**Table 11. EEPROM Memory Map**

ADDRESS	BITS [7:4]	BITS [3:0]	DEFINITION	
00	RB0[7:0]		Base PWM value for red (8 LSB bits)	-40...-25
01	RB1[7:0]			-24...-9
02	RB2[7:0]			-8...+7
03	RB3[7:0]			8...23
04	RB4[7:0]			24...39
05	RB5[7:0]			40...55
06	RB6[7:0]			56...71
07	RB7[7:0]			72...87
08	RB8[7:0]			88...103
09	RB9[7:0]			from 104
0a	GB0[7:0]		Base PWM value for green (8 LSB bits)	-40...-25
0b	GB1[7:0]			-24...-9
0c	GB2[7:0]			-8...+7
0d	GB3[7:0]			8...23
0e	GB4[7:0]			24...39
0f	GB5[7:0]			40...55
10	GB6[7:0]			56...71
11	GB7[7:0]			72...87
12	GB8[7:0]			88...103
13	GB9[7:0]			from 104
14	BB0[7:0]		Base PWM value for blue (8 LSB bits)	-40...-25
15	BB1[7:0]			-24...-9
16	BB2[7:0]			-8...+7
17	BB3[7:0]			8...23
18	BB4[7:0]			24...39
19	BB5[7:0]			40...55
1a	BB6[7:0]			56...71
1b	BB7[7:0]			72...87
1c	BB8[7:0]			88...103
1d	BB9[7:0]			from 104
1e	LM20K[7:0]		Scaling values for LM20 sensor	K
1f	LM20B[7:0]			B
20			Not used	
...				
3f				
40	RC0[7:0]		Coefficient PWM value for red	-40...-25
41	RC1[7:0]			-24...-9
42	RC2[7:0]			-8...+7
43	RC3[7:0]			8...23
44	RC4[7:0]			24...39
45	RC5[7:0]			40...55
46	RC6[7:0]			56...71
47	RC7[7:0]			72...87
48	RC8[7:0]			88...103
49	RC9[7:0]			From 104

**Table 11. EEPROM Memory Map (continued)**

ADDRESS	BITS [7:4]	BITS [3:0]	DEFINITION	
4a	GC0[7:0]		Coefficient PWM value for green	
4b	GC1[7:0]			–40...–25
4c	GC2[7:0]			–24...–9
4d	GC3[7:0]			–8...+7
4e	GC4[7:0]			8...23
4f	GC5[7:0]			24...39
50	GC6[7:0]			40...55
51	GC7[7:0]			56...71
52	GC8[7:0]			72...87
53	GC9[7:0]			88...103
54	BC0[7:0]		Coefficient PWM value for blue	
55	BC1[7:0]			–40...–25
56	BC2[7:0]			–24...–9
57	BC3[7:0]			–8...+7
58	BC4[7:0]			8...23
59	BC5[7:0]			24...39
5a	BC6[7:0]			40...55
5b	BC7[7:0]			56...71
5c	BC8[7:0]			72...87
5d	BC9[7:0]			88...103
5e	SHF[7:0]		From 104	
5f	RED_CUR		Self-heating factor	
60	GREEN_CUR		Red LED current	
61	BLUE_CUR		Green LED current	
62			Blue LED current	
...			Not used	
6f				
70	LM20B[11:8]	LM20K[11:8]		
71	BB9[11:8]	BB8[11:8]	Scaling values for LM20 sensor	
72	BB7[11:8]	BB6[11:8]		
73	BB5[11:8]	BB4[11:8]		
74	BB3[11:8]	BB2[11:8]		
75	BB1[11:8]	BB0[11:8]		
76	GB9[11:8]	GB8[11:8]	Base PWM value for blue (high bits)	
77	GB7[11:8]	GB6[11:8]		
78	GB5[11:8]	GB4[11:8]		
79	GB3[11:8]	GB2[11:8]		
7a	GB1[11:8]	GB0[11:8]		
7b	RB9[11:8]	RB8[11:8]	Base PWM value for green (high bits)	
7c	RB7[11:8]	RB6[11:8]		
7d	RB5[11:8]	RB4[11:8]		
7e	RB3[11:8]	RB2[11:8]		
7f	RB1[11:8]	RB0[11:8]		
				Base PWM value for red (high bits)

The EEPROM data can be read, written, and erased through the serial interface. The boost converter is used to generate the write and erase voltage for the memory. All operations are done in page mode. The page address has to be written in the **EEPROM\_control** register before access to the EEPROM. Incremental access can be used both in I<sup>2</sup>C and SPI modes to speed up access. During EEPROM access the **<rgb\_auto>** control bit in **rgb\_control** register must be low.

The EEPROM has 4 pages; only one page at time can be mirrored at the register map. For getting access to page, the number of page must be set by **<ee\_page[1:0]>** bits in the **EEPROM\_control** register(0DH). The page register address range is from 40H to 5FH.

**Table 12. EEPROM Pages**

<b>&lt;ee_page[1:0]&gt; (bits1-0)</b>	<b>00</b>	page0 (00H-1FH)
	<b>01</b>	page1 (20H-3FH)
	<b>10</b>	page2 (40H-5FH)
	<b>11</b>	page3 (60H-7FH)

The EEPROM consists of two types of memory, 128 × 8 EEPROM (non volatile memory) and 128 × 8 synchronous random access memory (SRAM). The EEPROM is used to store calibrated RGB control values when the system is powered off. SRAM is used as working memory during operation.

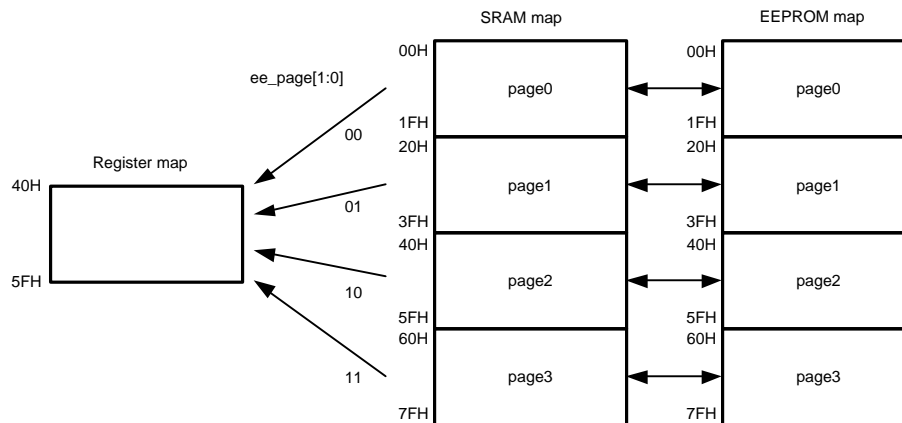

**Figure 31. EEPROM Memory**

EEPROM content is copied into SRAM always when the chip is taken from stand-by mode to active mode. Copying to SRAM can also be made during operation by writing the **<ee\_read>** bit high and low in the **EEPROM control** (0DH) register. For reading the data from the SRAM, the page number must be set with **<ee\_page[1:0]>** bits and the page read from addresses 40H – 5FH.

The EEPROM must be erased before programming. The erase command erases one page at time, which must be selected with **<ee\_page[1:0]>** bits. This operation starts after setting and resetting **<ee\_erase>** and takes about 100 ms after rising **<ee\_erase>** bit. During erasing **<ee\_prog>** bit of the **EEPROM\_CONTROL** register is low. Corresponding SRAM area is erased with this operation also. **<ee\_erase>** and **<ee\_prog>** can be set only one command at a time (erase or program).

During programming the content of SRAM is copied to EEPROM, EEPROM programming cycle has two steps. At first, write the whole content of the SRAM, all 4 pages. The whole page can be written during one SPI/I<sup>2</sup>C cycle in the auto-increment mode. Second step is programming the EEPROM. This operation starts after writing **<ee\_prog>** high and back low and takes about 100 ms after rising **<ee\_prog>** bit. During programming **<ee\_prog>** bit of the **EEPROM\_CONTROL** register is low. For EEPROM erasing and programming the chip has to be in active mode (**<NSTBY>** high), the boost must be off (**<in\_boost>** low) and the boost voltage set to 18 V (**boost output** register value 12H).

## 7.6 Register Maps

### 7.6.1 LP5520 Registers, Control Bits, and Default Values

All registers have their default value after power-on or reset. Default value for correction registers is 1000 0000 (multiplier = 1). Default value for adaptive voltage control and fast PWM is on. Default value for current set registers is 55H which sets the current to 20 mA. Default value for all other register bits is 0. Note that in automatic compensation mode the LED currents are obtained from the EEPROM.

Bits with **r/o** are read-only bits.

ADR	REG NAME	D7	D6	D5	D4	D3	D2	D1	D0	DEFAULT
00H	rgb control	seq_mode[1]	seq_mode[0]	en_fade	pwm_fast	rgb_auto	en_b	en_g	en_r	0001 0000
01H	current control (R)	cc_r[7]	cc_r[6]	cc_r[5]	cc_r[4]	cc_r[3]	cc_r[2]	cc_r[1]	cc_r[0]	0101 0101
02H	current control (G)	cc_g[7]	cc_g[6]	cc_g[5]	cc_g[4]	cc_g[3]	cc_g[2]	cc_g[1]	cc_g[0]	0101 0101
03H	current control (B)	cc_b[7]	cc_b[6]	cc_b[5]	cc_b[4]	cc_b[3]	cc_b[2]	cc_b[1]	cc_b[0]	0101 0101
04H	pwm brightness					brc_off	bri2	bri1	bri0	0000 0000
05H	boost output				vprog[4]	vprog[3]	vprog[2]	vprog[1]	vprog[0]	0000 0000
06H	control			adc_ch	comp_sel	en_autoload	vout_auto	en_boost	nstby	0000 0100
08H	ADC_hi_byte					bit11 (r/o)	bit10 (r/o)	bit9 (r/o)	bit8 (r/o)	
09H	ADC_low_byte	bit7 (r/o)	bit6 (r/o)	bit5 (r/o)	bit4 (r/o)	bit3 (r/o)	bit2 (r/o)	bit1 (r/o)	bit0 (r/o)	
0AH	R correction	corr_r[7]	corr_r[6]	corr_r[5]	corr_r[4]	corr_r[3]	corr_r[2]	corr_r[1]	corr_r[0]	1000 0000
0BH	G correction	corr_g[7]	corr_g[6]	corr_g[5]	corr_g[4]	corr_g[3]	corr_g[2]	corr_g[1]	corr_g[0]	1000 0000
0CH	B correction	corr_b[7]	corr_b[6]	corr_b[5]	corr_b[4]	corr_b[3]	corr_b[2]	corr_b[1]	corr_b[0]	1000 0000
0DH	EEPROM Control	ee_ready (r/o)	ee_erase	ee_prog	ee_read			ee_page[1 ]	ee_page[0]	0000 0000

Register addresses from 40H to 5FH contain the EEPROM page. EEPROM access is described in the Calibration Memory chapter.

### 7.6.1.1 Register Bit Conventions

Each register is shown with a key indicating the accessibility of the each individual bit, and the initial condition:

**Table 13. Register Bit Accessibility And Initial Condition**

Key	Bit Accessibility
rw	Read/write
r	Read only
-0, -1	Condition after POR

#### rgb\_control (00H) – RGB LEDs Control Register

7	6	5	4	3	2	1	0
seq_mode1	seq_mode0	en_fade	pwm_fast	rgb_auto	en_b	en_g	en_r
rw-0	rw-0	rw-0	rw-1	rw-0	rw-0	rw-0	rw-0

seq_mode[1:0]	Bits 6 - 7	0 0 – overlapping PWM mode 0 1 – sequential mode with 2 PWM pulses 1 0 – sequential mode with 3 PWM pulses 1 1 – sequential mode with 4 PWM pulses
en_fade	Bit 5	0 – automatic fade disabled 1 – automatic fade enabled
pwm_fast	Bit 4	0 – normal PWM frequency 1.22 kHz 1 – high PWM frequency 19.52 kHz
rgb_auto	Bit 3	0 – automatic compensation disabled 1 – automatic compensation enabled
en_b	Bit 2	0 – blue LED output B <sub>OUT</sub> disabled 1 – blue LED output B <sub>OUT</sub> enabled
en_g	Bit 1	0 – green LED output G <sub>OUT</sub> disabled 1 – green LED output G <sub>OUT</sub> enabled
en_r	Bit 0	0 – red LED output R <sub>OUT</sub> disabled 1 – red LED output R <sub>OUT</sub> enabled

#### current\_control\_R (01H) – Red LED Current Control Register

7	6	5	4	3	2	1	0
cc_r[7]	cc_r[6]	cc_r[5]	cc_r[4]	cc_r[3]	cc_r[2]	cc_r[1]	cc_r[0]
rw-0	rw-1	rw-0	rw-1	rw-0	rw-1	rw-0	rw-1

cc_r[7:0]	Bits 7 - 0	Adjustment	
		cc_r[7:0]	Typical driver current (mA)
		0000 0000	0
		0000 0001	0.234
		0000 0010	0.468
		0000 0011	0.702
		...	...
		1111 1101	59.202
		1111 1110	59.436
		1111 1111	59.670

#### current\_control\_G (02H) – Green LED Current Control Register

7	6	5	4	3	2	1	0
cc_g[7]	cc_g[6]	cc_g[5]	cc_g[4]	cc_g[3]	cc_g[2]	cc_g[1]	cc_g[0]
rw-0	rw-1	rw-0	rw-1	rw-0	rw-1	rw-0	rw-1

**current\_control\_B (03H) – Blue LED Current Control Register**

7	6	5	4	3	2	1	0
cc_b[7]	cc_b[6]	cc_b[5]	cc_b[4]	cc_b[3]	cc_b[2]	cc_b[1]	cc_b[0]
rw-0	rw-1	rw-0	rw-1	rw-0	rw-1	rw-0	rw-1

**pwm\_brightness (04H) – Brightness Control Register**

7	6	5	4	3	2	1	0
				brc_off	bri[2]	bri[1]	bri[0]
r-0	r-0	r-0	rw-0	r-0	rw-0	rw-0	rw-0

<b>brc_off</b> <b>bri[2:0]</b>	Bit 4 Bits 2-0	<b>brc_off = 0 - stand-alone mode, brightness is defined with external BRC signal</b>		
		<b>brc_off = 1 - brightness is defined with bri[2:0]</b>		
		<b>Control</b>	<b>Multiplier</b>	<b>Intensity %</b>
		0	0.008	0.8
		1	0.016	1.6
		10	0.031	3.1
		11	0.063	6.3
		100	0.125	12.5
		101	0.250	25
		110	0.500	50
111	1.000	100		

**boost\_output (05H) – Boost Output Voltage Control Register**

7	6	5	4	3	2	1	0
			vprog[4]	vprog[3]	vprog[2]	vprog[1]	vprog[0]
r-0	r-0	r-0	r-0	rw-0	rw-0	rw-0	rw-0

<b>vprog[4:0]</b>	Bits 4 - 0	<b>Adjustment</b>	
		<b>vprog[4:0]</b>	<b>Typical boost output voltage (V)</b>
		00101	5.0
		00110	6.0
		00111	7.0
		01000	8.0
		01001	9.0
		01010	10.0
		01011	11.0
		01100	12.0
		01101	13.0
		01110	14.0
		01111	15.0
		10000	16.0
		10001	17.0
		10010	18.0
10011	19.0		
10100	20.0		

**control (06H) – Control Register**

7	6	5	4	3	2	1	0
		<b>adc_ch</b>	<b>comp_sel</b>	<b>en_autoload</b>	<b>vout_auto</b>	<b>en_boost</b>	<b>nstby</b>
r-0	r-0	rw-0	rw-0	rw-0	rw-1	rw-0	rw-0

<b>adc_ch</b>	Bit 5	0 – compensation depends from the external LM20 temperature sensor 1 – compensation depends from forward voltage of the red LED as temperature sensor
<b>comp_sel</b>	Bit 4	0 – compensation based on S1_IN input 1 – compensation based on S2_IN input
<b>en_autoload</b>	Bit 3	0 – internal boost converter loader off 1 – internal boost converter loader off
<b>vout_auto</b>	Bit 2	0 – manual boost output adjustment with boost_output register 1 – automatic adaptive boost output adjustment
<b>en_boost</b>	Bit 1	0 – boost converter disabled 1 – boost converter enabled
<b>nstby</b>	Bit 0	0 – LP5520 standby mode 1 – LP5520 active mode

**ADC\_hi\_byte (08H) – Analog Digital Converter Output, bits 8-11**

7	6	5	4	3	2	1	0
				<b>adc[11]</b>	<b>adc[10]</b>	<b>adc[9]</b>	<b>adc[8]</b>
r-0	r-0	r-0	r-0	r-0	r-0	r-0	r-0

**ADC\_low\_byte (09H) – Analog Digital Converter Output, bits 0-7**

7	6	5	4	3	2	1	0
<b>adc[7]</b>	<b>adc[6]</b>	<b>adc[5]</b>	<b>adc[4]</b>	<b>adc[3]</b>	<b>adc[2]</b>	<b>adc[1]</b>	<b>adc[0]</b>
r-0	r-0	r-0	r-0	r-0	r-0	r-0	r-0

**r\_correction (0AH) – Additional Brightness Correction Value Register for Red LED**

7	6	5	4	3	2	1	0
<b>corr_r[7]</b>	<b>corr_r[6]</b>	<b>corr_r[5]</b>	<b>corr_r[4]</b>	<b>corr_r[3]</b>	<b>corr_r[2]</b>	<b>corr_r[1]</b>	<b>corr_r[0]</b>
rw-1	rw-0	rw-0	rw-0	rw-0	rw-0	rw-0	rw-0

<b>corr_r[7:0]</b>	Bits 7-0	<b>Correction</b>	
		<b>corr_r[7:0]</b>	<b>Multiplier</b>
		0000 0000	0
		0000 0001	0.0078
		0000 0010	0.0156
		...	...
		1000 0000	1.000
		...	...
		1111 1101	1.991
		1111 1110	1.999
1111 1111	2.000		

**g\_correction (0BH) – Additional Brightness Correction Value Register for Green LED**

7	6	5	4	3	2	1	0
corr_g[7]	corr_g[6]	corr_g[5]	corr_g[4]	corr_g[3]	corr_g[2]	corr_g[1]	corr_g[0]
rw-1	rw-0	rw-0	rw-0	rw-0	rw-0	rw-0	rw-0

**b\_correction (0CH) – Additional Brightness Correction Value Register for Blue LED**

7	6	5	4	3	2	1	0
corr_b[7]	corr_b[6]	corr_b[5]	corr_b[4]	corr_b[3]	corr_b[2]	corr_b[1]	corr_b[0]
rw-1	rw-0	rw-0	rw-0	rw-0	rw-0	rw-0	rw-0

**EEPROM\_control (0DH) – EEPROM Control Register**

7	6	5	4	3	2	1	0
ee_ready	ee_erase	ee_prog	ee_read			ee_page[1]	ee_page[0]
r-1	rw-0	rw-0	r-0	r-0	r-0	rw-0	rw-0

<b>ee_ready</b>	Bit 7	EEPROM operations ready bit (read only)			
<b>ee_erase</b>	Bit 6	Start bit for erasing sequence			
<b>ee_prog</b>	Bit 5	Start bit for programming sequence			
<b>ee_read</b>	Bit 4	Read EEPROM data to SRAM			
<b>ee_page[1:0]</b>	Bits 1-0	<b>ee_page[1]</b>	<b>ee_page[0]</b>	<b>page</b>	<b>EEPROM addresses</b>
		0	0	0	00H-1FH (0-31)
		0	1	1	20H-3FH (32-63)
		1	0	2	40H-5FH (64-95)
		1	1	4	60H-7FH (96-127)



## Typical Applications (continued)

### 8.2.1.1 Design Requirements

For typical RGB backlight LED-driver I<sup>2</sup>C-bus applications, use the parameters listed in [Table 14](#).

**Table 14. Design Parameters**

DESIGN PARAMETER	EXAMPLE VALUE
Input voltage range	2.9 V to 5.5 V
Maximum output voltage	20 V
LED configuration	3 strings with 6 LEDs in series
LED current	Maximum 60 mA per string
Brightness control	I <sup>2</sup> C
Operation mode	Automatic/normal
Input capacitor	10 $\mu$ F, 6.3 V
Output capacitors	2 $\times$ 4.7 $\mu$ F, 25 V
Inductor	4.7 $\mu$ H
Temperature sensor	LM20

### 8.2.1.2 Detailed Design Procedure

#### 8.2.1.2.1 Recommended External Components

##### 8.2.1.2.1.1 Output Capacitor: $C_{OUT}$

The output capacitor  $C_{OUT}$  directly affects the magnitude of the output ripple voltage. In general, the higher the value of  $C_{OUT}$ , the lower the output ripple magnitude. Multilayer ceramic capacitors with low ESR are the best choice. Capacitor voltage rating must be sufficient; TI recommends 25 V or greater. Examples of suitable capacitors are: TDK C3216X5R1E475K, Panasonic ECJ3YB1E475K, and Panasonic ECJ4YB1E475K.

Some ceramic capacitors, especially those in small packages, exhibit a strong capacitance reduction with the increased applied voltage (DC bias effect). The capacitance value can fall below half of the nominal capacitance. Output capacitance that is too low can make the boost converter unstable. Output capacitor value reduction due to DC bias must be less than 70% at 20 V (minimum 3  $\mu$ F of real capacitance remaining).

##### 8.2.1.2.1.2 Input Capacitor: $C_{IN}$

The input capacitor  $C_{IN}$  directly affects the magnitude of the input ripple voltage and to a lesser degree the  $V_{OUT}$  ripple. A higher value  $C_{IN}$  gives a lower  $V_{IN}$  ripple.

##### 8.2.1.2.1.3 Output Diode: $D_{OUT}$

A schottky diode must be used for the output diode. To maintain high efficiency the average current rating of the Schottky diode must be greater than the peak inductor current (1 A). Schottky diodes with a low forward drop and fast switching speeds are ideal for increasing efficiency in portable applications. Choose a reverse breakdown voltage of the schottky diode significantly larger (approximately 30 V) than the output voltage. Do not use ordinary rectifier diodes, because slow switching speeds and long recovery times cause the efficiency and the load regulation to suffer. A schottky diode with low parasitic capacitance helps in reducing EMI noise. Examples of suitable diodes are Central Semiconductor CMMSH1-40 and Infineon BAS52-02V.

##### 8.2.1.2.1.4 EMI Filter Components: $C_{SW}$ , $R_{SW}$ , $L_{SW}$ And $C_{HF}$

EMI filter ( $R_{SW}$ ,  $C_{SW}$  and  $L_{SW}$ ) on the SW pin may be needed to slow down the fast switching edges and reduce ringing. These components must be as near as possible to the SW pin to ensure reliable operation. High frequency capacitor ( $C_{SW}$ ) in the boost output helps in suppressing the high frequency noise from the switcher. 50V or greater voltage rating is recommended for the capacitors. The ferrite bead DC resistance must be less than 0.1  $\Omega$  and current rating 1 A or above. The impedance at 100 MHz must be from 30  $\Omega$  to 300  $\Omega$ . Examples of suitable types are TDK MPZ1608S101A and Taiyo-Yuden FBMH 1608HM600-T.

### 8.2.1.2.1.5 Inductor: $L_1$

A 4.7- $\mu$ H shielded inductor is suggested for LP5520 boost converter. The inductor must have a higher saturation current rating than the peak current it receives during circuit operation (0.5 A – 1 A depending on the output current). Equivalent series resistance (ESR) less than 500-m $\Omega$  is suggested for high efficiency. Open core inductors cause flux linkage with circuit components and interfere with the normal operation of the circuit. This must be avoided. For high efficiency, choose an inductor with a high-frequency core material such as ferrite to reduce the core losses. To minimize radiated noise, use a toroid, pot core or shielded core inductor. The inductor must be connected to the SW pin as close to the device as possible. Examples of suitable inductors are: TDK VLF3010AT-4R7MR70 and Coilcraft LPS3010-472NL.

### 8.2.1.2.1.6 List Of Recommended External Components

SYMBOL	SYMBOL EXPLANATION	VALUE	UNIT	TYPE
$C_{VDDA}$	C between $V_{DDA}$ and GND	100	nF	Ceramic, X7R / X5R
$C_{VDDD}$	C between $V_{DDD}$ and GND	100	nF	Ceramic, X7R, X5R
$C_{VLDO}$	C between $V_{LDO}$ and GND	1	$\mu$ F	Ceramic, X7R / X5R
$C_{VDDIO}$	C between VDDIO and GND	100	nF	Ceramic, X7R / X5R
$C_{OUT}$	C between FB and GND	$2 \times 4.7$	$\mu$ F	Ceramic, X7R / X5R, tolerance $\pm 10\%$ , DC bias effect approximately 30% at 20 V
$C_{IN}$	C between battery voltage and GND	10	$\mu$ F	Ceramic, X7R / X5R
L1	L between SW and $V_{BAT}$	4.7	$\mu$ H	Shielded, low ESR, $I_{SAT}$ 0.5 A
D1	Rectifying diode ( $V_f$ at maximum load)	0.3 – 0.5	V	Schottky diode, reverse voltage 30 V, repetitive peak current 0.5 A
$C_{SW}$	Optional C in EMI filter	330	pF	Ceramic, X7R / X5R, 50V
$R_{SW}$	Optional R in EMI filter	3.9	$\Omega$	$\pm 1\%$
$C_{HF}$	Optional high frequency output C	33 - 100	pF	Ceramic, X7R, X5R, 50V
$L_{SW}$	Ferrite bead in SW pin	30 - 300	$\Omega$ at 100 Mhz	
LEDs				User Defined

### 8.2.1.3 Application Curves

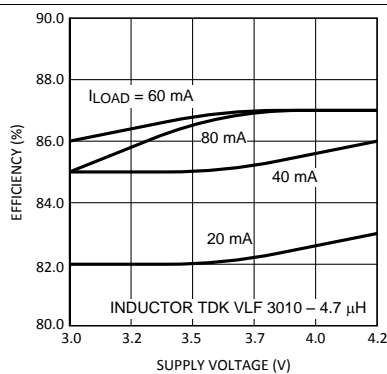

**Figure 33. Boost Converter Efficiency**

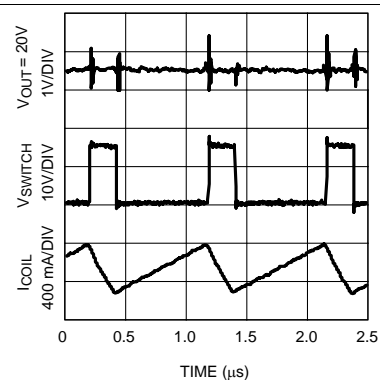

**Figure 34. Boost Typical Waveforms at 60-mA Load**

### 8.2.2 Stand-Alone Typical Application

In stand-alone mode the operation is controlled through a single PWM brightness input, BRC. After power-up or reset the LP5520 is ready for stand-alone operation without any setup through the serial interface. The stand-alone mode is entered with a rising edge in the BRC input. The boost converter operates in adaptive mode. The LED current settings are read from EEPROM. The LED brightness is controlled with a PWM signal in the BRC input. The BRC PWM frequency must be between 2 and 10 kHz.

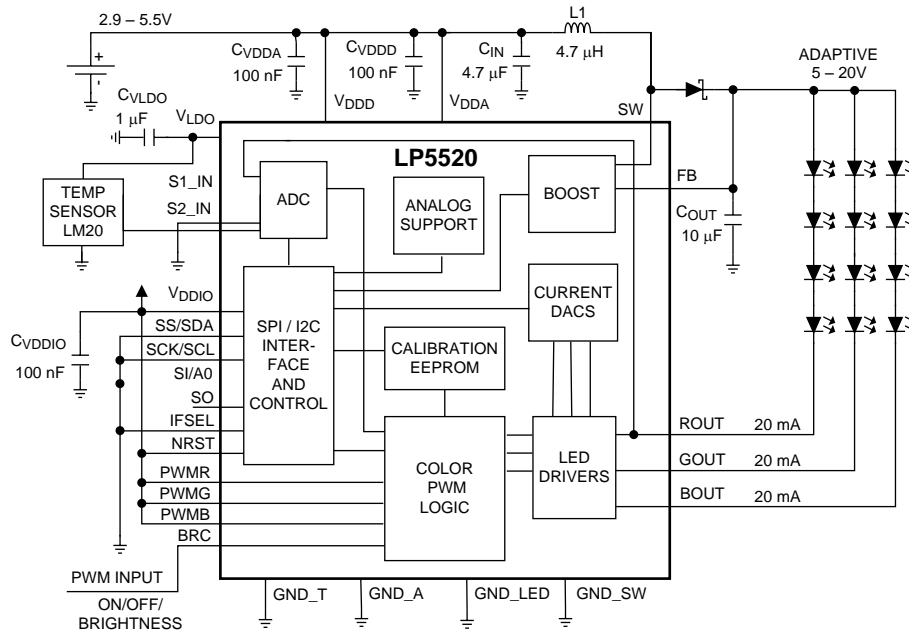

Figure 35. Typical Stand-Alone Application

#### 8.2.2.1 Design Requirements

For typical RGB backlight LED-driver stand-alone applications, use the parameters listed in [Table 14](#).

Table 15. Design Parameters

DESIGN PARAMETER	EXAMPLE VALUE
Input voltage range	2.9 V to 5.5 V
Maximum output voltage	20 V
LED configuration	3 strings with 6 LEDs in series
LED current	Maximum 60 mA per string
Brightness control	With BRC input, 2-kHz PWM signal; 8 steps
Operation mode	Stand-alone operation
Input capacitor	10 µF, 6.3 V
Output capacitors	2 × 4.7 µF, 25 V
Inductor	4.7 µH
Temperature sensor	LM20

#### 8.2.2.2 Detailed Design Procedure

See [Detailed Design Procedure](#).

#### 8.2.2.3 Application Curves

See [Application Curves](#).

## 9 Power Supply Recommendations

The device is designed to operate with an input voltage supply range from 2.9 V to 5.5 V. In typical application this is from single Li-ion battery cell. This input supply must be well regulated and able to withstand maximum input current and maintain stable voltage without voltage drop even at load transition condition (start-up or rapid brightness change). The resistance of the input supply rail must be low enough that the input current transient does not cause a drop below the 2.9-V level in the LP5520 supply voltage.

## 10 Layout

### 10.1 Layout Guidelines

[Figure 36](#) shows a layout recommendation for the LP5520 used to demonstrate the principles of good layout. This layout can be adapted to the actual application layout if or where possible. It is important that all boost components are close to the chip, and the high current traces must be wide enough. By placing boost components on one side of the chip it is easy to keep the ground plane intact below the high current paths. This way other chip pins can be routed more easily without splitting the ground plane. Bypass VLDO capacitor must as close as possible to the device.

Here are main points to help with the PCB layout work:

- Current loops need to be minimized:
  - For low frequency the minimal current loop can be achieved by placing the boost components as close to the SW and GND\_SW pins as possible. Input and output capacitor grounds must be close to each other to minimize current loop size.
  - Minimal current loops for high frequencies can be achieved by making sure that the ground plane is intact under the current traces. High-frequency return currents try to find route with minimum impedance, which is the route with minimum loop area, not necessarily the shortest path. Minimum loop area is formed when return current flows just under the *positive* current route in the ground plane, if the ground plane is intact under the route.
- GND plane must be intact under the high current boost traces to provide the shortest possible return path and smallest possible current loops for high frequencies.
- Current loops when the boost switch is conducting and not conducting must be on the same direction in optimal case.
- Inductor must be placed so that the current flows in the same direction as in the current loops. Rotating inductor 180° changes current direction.
- Use separate power and noise-free grounds or ground areas. Power ground is used for boost converter return current and noise-free ground for more sensitive signals, like LDO bypass capacitor grounding as well as grounding the GNDA pin of the device itself.
- Boost output feedback voltage to LEDs must be taken out after the output capacitors, not straight from the diode cathode.
- Place LDO 1- $\mu$ F bypass capacitor as close to the LDO pin as possible.
- Input and output capacitors need strong grounding (wide traces, many vias to GND plane).
- If two output capacitors are used they need symmetrical layout to get both capacitors working ideally.
- Output ceramic capacitors have DC-bias effect. If the output capacitance is too low, it can cause boost to become unstable on some loads; this increases EMI. DC bias characteristics should be obtained from the component manufacturer; DC bias is not taken into account on component tolerance. TI recommends X5R/X7R capacitors.

LP5520

SNVS440B –MAY 2007–REVISED MARCH 2016

www.ti.com

10.2 Layout Example

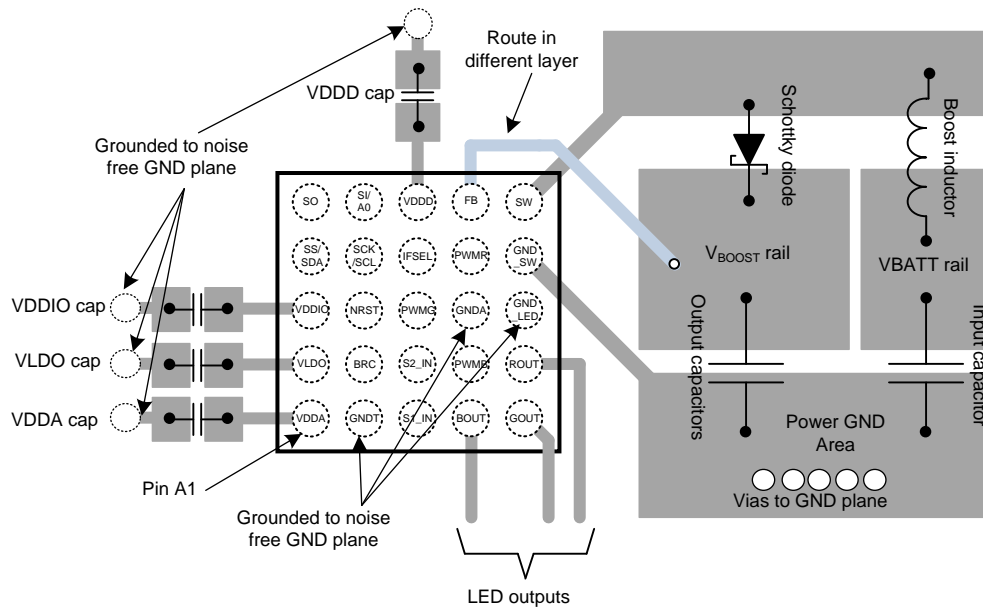

Figure 36. LP5520 Layout Example

## 11 Device and Documentation Support

### 11.1 Device Support

#### 11.1.1 Third-Party Products Disclaimer

TI'S PUBLICATION OF INFORMATION REGARDING THIRD-PARTY PRODUCTS OR SERVICES DOES NOT CONSTITUTE AN ENDORSEMENT REGARDING THE SUITABILITY OF SUCH PRODUCTS OR SERVICES OR A WARRANTY, REPRESENTATION OR ENDORSEMENT OF SUCH PRODUCTS OR SERVICES, EITHER ALONE OR IN COMBINATION WITH ANY TI PRODUCT OR SERVICE.

### 11.2 Documentation Support

#### 11.2.1 Related Documentation

For additional information, see the following:

*DSBGA Wafer Level Chip Scale Package* ([SNVA009](#))

### 11.3 Community Resources

The following links connect to TI community resources. Linked contents are provided "AS IS" by the respective contributors. They do not constitute TI specifications and do not necessarily reflect TI's views; see TI's [Terms of Use](#).

**TI E2E™ Online Community** *TI's Engineer-to-Engineer (E2E) Community*. Created to foster collaboration among engineers. At [e2e.ti.com](#), you can ask questions, share knowledge, explore ideas and help solve problems with fellow engineers.

**Design Support** *TI's Design Support* Quickly find helpful E2E forums along with design support tools and contact information for technical support.

### 11.4 Trademarks

E2E is a trademark of Texas Instruments.

SPI is a trademark of Motorola.

All other trademarks are the property of their respective owners.

### 11.5 Electrostatic Discharge Caution



These devices have limited built-in ESD protection. The leads should be shorted together or the device placed in conductive foam during storage or handling to prevent electrostatic damage to the MOS gates.

### 11.6 Glossary

[SLYZ022](#) — *TI Glossary*.

This glossary lists and explains terms, acronyms, and definitions.

## 12 Mechanical, Packaging, and Orderable Information

The following pages include mechanical, packaging, and orderable information. This information is the most current data available for the designated devices. This data is subject to change without notice and revision of this document. For browser-based versions of this data sheet, refer to the left-hand navigation.

**PACKAGING INFORMATION**

Orderable Device	Status (1)	Package Type	Package Drawing	Pins	Package Qty	Eco Plan (2)	Lead/Ball Finish (6)	MSL Peak Temp (3)	Op Temp (°C)	Device Marking (4/5)	Samples
LP5520TL/NOPB	ACTIVE	DSBGA	YZR	25	250	Green (RoHS & no Sb/Br)	SNAGCU	Level-1-260C-UNLIM	-30 to 85	5520	<a href="#">Samples</a>
LP5520TLX/NOPB	ACTIVE	DSBGA	YZR	25	3000	Green (RoHS & no Sb/Br)	SNAGCU	Level-1-260C-UNLIM	-30 to 85	5520	<a href="#">Samples</a>

(1) The marketing status values are defined as follows:

**ACTIVE:** Product device recommended for new designs.

**LIFEBUY:** TI has announced that the device will be discontinued, and a lifetime-buy period is in effect.

**NRND:** Not recommended for new designs. Device is in production to support existing customers, but TI does not recommend using this part in a new design.

**PREVIEW:** Device has been announced but is not in production. Samples may or may not be available.

**OBSELETE:** TI has discontinued the production of the device.

(2) Eco Plan - The planned eco-friendly classification: Pb-Free (RoHS), Pb-Free (RoHS Exempt), or Green (RoHS & no Sb/Br) - please check <http://www.ti.com/productcontent> for the latest availability information and additional product content details.

**TBD:** The Pb-Free/Green conversion plan has not been defined.

**Pb-Free (RoHS):** TI's terms "Lead-Free" or "Pb-Free" mean semiconductor products that are compatible with the current RoHS requirements for all 6 substances, including the requirement that lead not exceed 0.1% by weight in homogeneous materials. Where designed to be soldered at high temperatures, TI Pb-Free products are suitable for use in specified lead-free processes.

**Pb-Free (RoHS Exempt):** This component has a RoHS exemption for either 1) lead-based flip-chip solder bumps used between the die and package, or 2) lead-based die adhesive used between the die and leadframe. The component is otherwise considered Pb-Free (RoHS compatible) as defined above.

**Green (RoHS & no Sb/Br):** TI defines "Green" to mean Pb-Free (RoHS compatible), and free of Bromine (Br) and Antimony (Sb) based flame retardants (Br or Sb do not exceed 0.1% by weight in homogeneous material)

(3) MSL, Peak Temp. - The Moisture Sensitivity Level rating according to the JEDEC industry standard classifications, and peak solder temperature.

(4) There may be additional marking, which relates to the logo, the lot trace code information, or the environmental category on the device.

(5) Multiple Device Markings will be inside parentheses. Only one Device Marking contained in parentheses and separated by a "~" will appear on a device. If a line is indented then it is a continuation of the previous line and the two combined represent the entire Device Marking for that device.

(6) Lead/Ball Finish - Orderable Devices may have multiple material finish options. Finish options are separated by a vertical ruled line. Lead/Ball Finish values may wrap to two lines if the finish value exceeds the maximum column width.

**Important Information and Disclaimer:** The information provided on this page represents TI's knowledge and belief as of the date that it is provided. TI bases its knowledge and belief on information provided by third parties, and makes no representation or warranty as to the accuracy of such information. Efforts are underway to better integrate information from third parties. TI has taken and continues to take reasonable steps to provide representative and accurate information but may not have conducted destructive testing or chemical analysis on incoming materials and chemicals. TI and TI suppliers consider certain information to be proprietary, and thus CAS numbers and other limited information may not be available for release.

In no event shall TI's liability arising out of such information exceed the total purchase price of the TI part(s) at issue in this document sold by TI to Customer on an annual basis.

**TAPE AND REEL INFORMATION**

**QUADRANT ASSIGNMENTS FOR PIN 1 ORIENTATION IN TAPE**

\*All dimensions are nominal

Device	Package Type	Package Drawing	Pins	SPQ	Reel Diameter (mm)	Reel Width W1 (mm)	A0 (mm)	B0 (mm)	K0 (mm)	P1 (mm)	W (mm)	Pin1 Quadrant
LP5520TL/NOPB	DSBGA	YZR	25	250	178.0	8.4	2.67	2.95	0.76	4.0	8.0	Q1
LP5520TLX/NOPB	DSBGA	YZR	25	3000	178.0	8.4	2.67	2.95	0.76	4.0	8.0	Q1

**TAPE AND REEL BOX DIMENSIONS**

\*All dimensions are nominal

Device	Package Type	Package Drawing	Pins	SPQ	Length (mm)	Width (mm)	Height (mm)
LP5520TL/NOPB	DSBGA	YZR	25	250	210.0	185.0	35.0
LP5520TLX/NOPB	DSBGA	YZR	25	3000	210.0	185.0	35.0

YZR0025

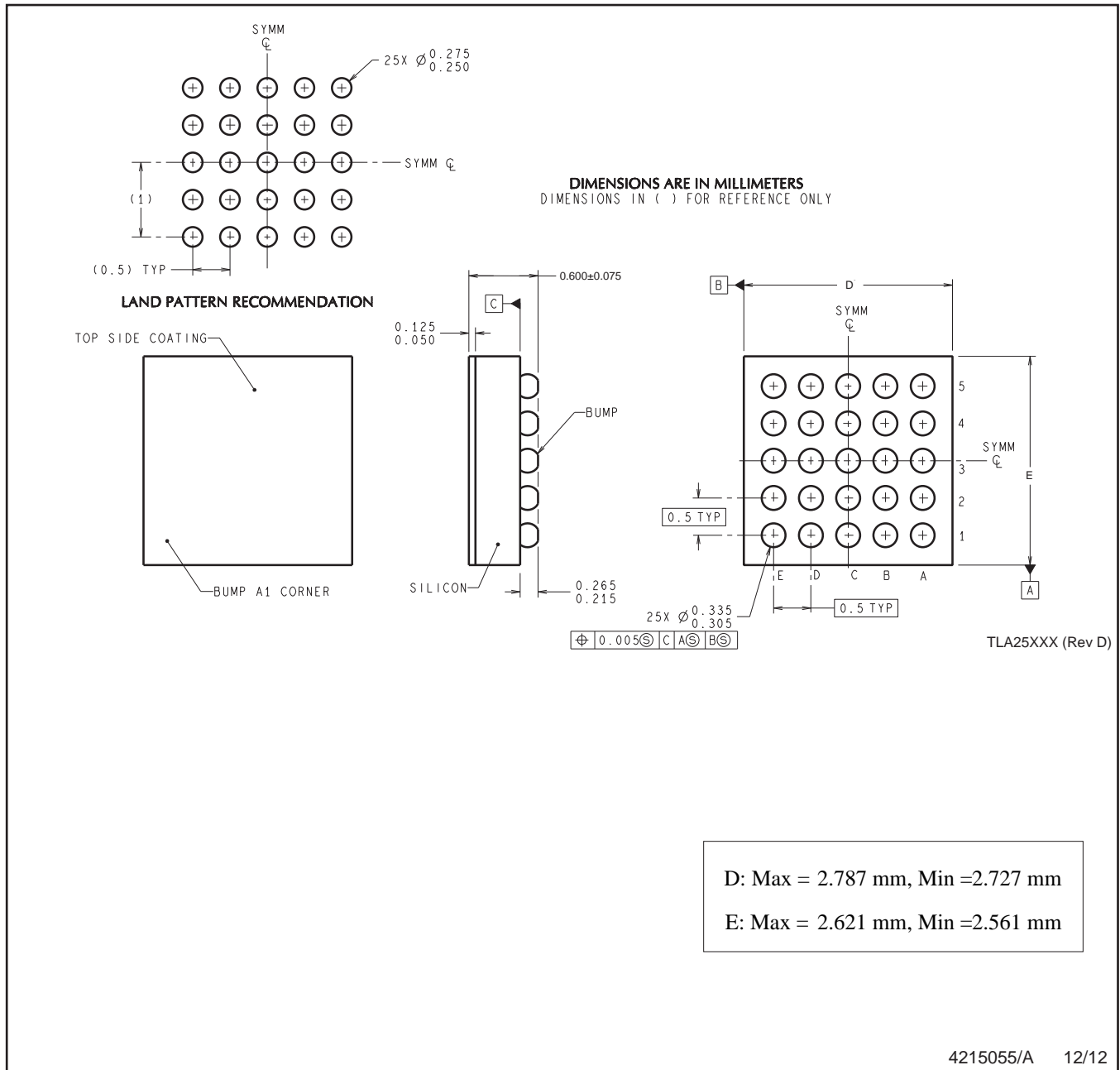

4215055/A 12/12

NOTES: A. All linear dimensions are in millimeters. Dimensioning and tolerancing per ASME Y14.5M-1994.  
B. This drawing is subject to change without notice.

## IMPORTANT NOTICE AND DISCLAIMER

TI PROVIDES TECHNICAL AND RELIABILITY DATA (INCLUDING DATASHEETS), DESIGN RESOURCES (INCLUDING REFERENCE DESIGNS), APPLICATION OR OTHER DESIGN ADVICE, WEB TOOLS, SAFETY INFORMATION, AND OTHER RESOURCES "AS IS" AND WITH ALL FAULTS, AND DISCLAIMS ALL WARRANTIES, EXPRESS AND IMPLIED, INCLUDING WITHOUT LIMITATION ANY IMPLIED WARRANTIES OF MERCHANTABILITY, FITNESS FOR A PARTICULAR PURPOSE OR NON-INFRINGEMENT OF THIRD PARTY INTELLECTUAL PROPERTY RIGHTS.

These resources are intended for skilled developers designing with TI products. You are solely responsible for (1) selecting the appropriate TI products for your application, (2) designing, validating and testing your application, and (3) ensuring your application meets applicable standards, and any other safety, security, or other requirements. These resources are subject to change without notice. TI grants you permission to use these resources only for development of an application that uses the TI products described in the resource. Other reproduction and display of these resources is prohibited. No license is granted to any other TI intellectual property right or to any third party intellectual property right. TI disclaims responsibility for, and you will fully indemnify TI and its representatives against, any claims, damages, costs, losses, and liabilities arising out of your use of these resources.

TI's products are provided subject to TI's Terms of Sale ([www.ti.com/legal/termsofsale.html](http://www.ti.com/legal/termsofsale.html)) or other applicable terms available either on [ti.com](http://ti.com) or provided in conjunction with such TI products. TI's provision of these resources does not expand or otherwise alter TI's applicable warranties or warranty disclaimers for TI products.

Mailing Address: Texas Instruments, Post Office Box 655303, Dallas, Texas 75265  
Copyright © 2019, Texas Instruments Incorporated

## Looking for pricing, stock, or lifecycle information?

Click below to explore more details on WIN SOURCE:

 [View LP5520TLX on WIN SOURCE](#)

 [Texas Instruments](#) Information

## Optimize Your Supply Chain with WIN SOURCE Solutions

-  Global Sourcing Solution
-  Obsolete Management
-  Cost Control Management
-  Shortage Management
-  Alternative Solution
-  Excess Inventory Management