



THE DATASHEET OF LP3954TLX/NOPB



Advanced Lighting Management Unit

Check for Samples: [LP3954](#)

FEATURES

- **Audio Synchronization for Color/RGB LEDs**
- **Command Based PWM Controlled RGB LED Drivers**
- **High Current Driver for Flash LED With Built-in Timing**
- **4+2 or 6 Low Voltage Constant Current White LED Drivers With Orogrammable 8-Bit Adjustment (0...25mA/LED)**
- **High Efficiency Boost DC-DC Converter**
- **SPI / I²C Compatible Interface**
- **Possibility for External PWM Dimming Control**
- **Possibility for Clock Synchronization for RGB Timing**
- **Ambient Light and Temperature Sensing Possibility**
- **Small Package – DSBGA, 3.0 x 3.0 x 0.6mm**

DESCRIPTION

LP3954 is an advanced lighting management unit for handheld devices. It drives any phone lights including display backlights, RGB, keypad and camera flash LEDs. The boost DC-DC converter drives high current loads with high efficiency. White LED backlight drivers are high efficiency low voltage structures with excellent matching and automatic fade in/ fade out function. The new stand-alone command based RGB controller is feature rich and easy to configure. Built-in audio synchronization feature allows user to synchronize the color LEDs to audio input. Integrated high current driver can drive camera flash LED or motor/vibra. Internal ADC can be used for ambient light or temperature sensing. The flexible SPI/I²C interface allows easy control of LP3954. Small DSBGA package together with minimum number of external components is a best fit for handheld devices.

APPLICATIONS

- **Cellular Phones**
- **PDA's, MP3 players**



Please be aware that an important notice concerning availability, standard warranty, and use in critical applications of Texas Instruments semiconductor products and disclaimers thereto appears at the end of this data sheet.

All trademarks are the property of their respective owners.

Typical Application

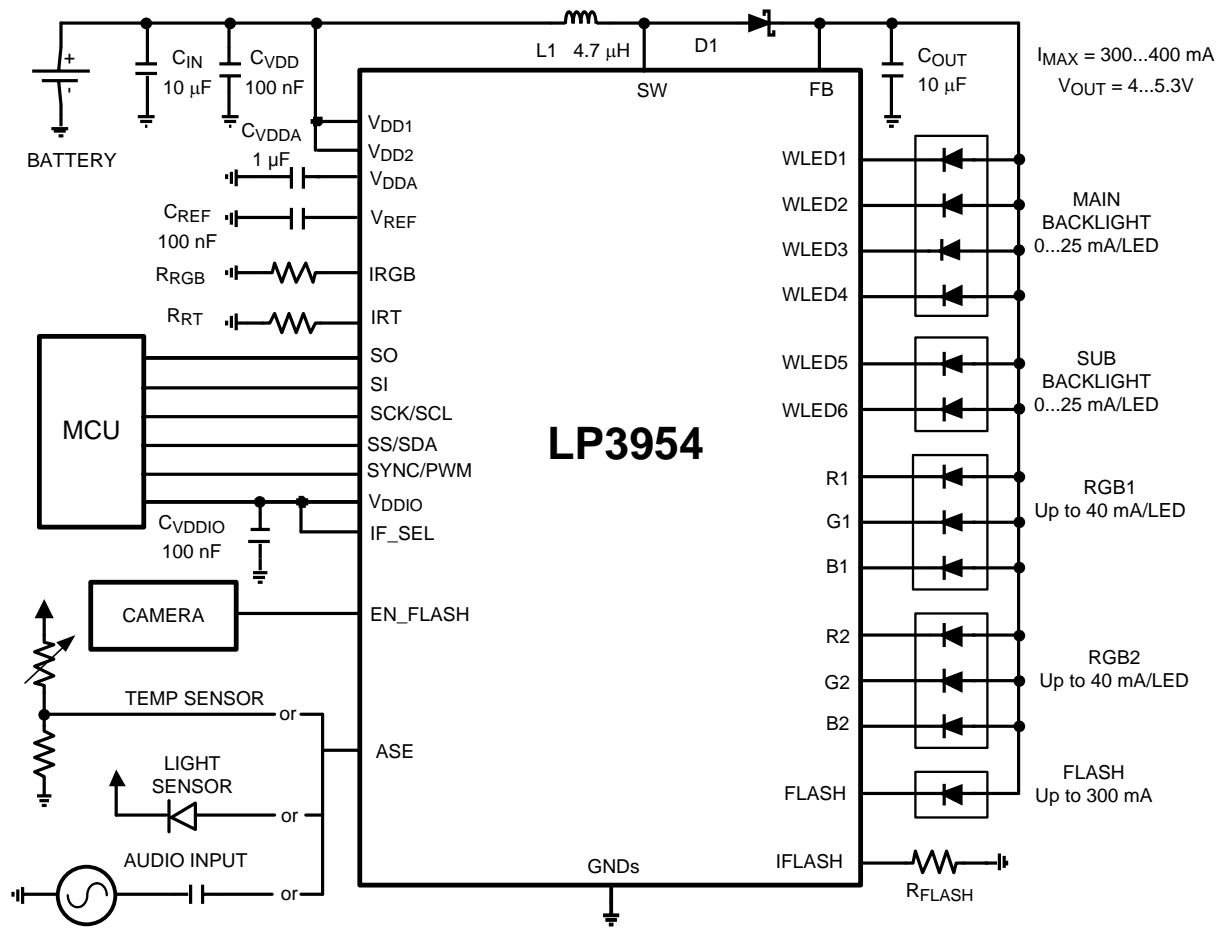

Connection Diagrams

DSBGA Package, 3.0 x 3.0 x 0.6mm, 0.5mm pitch Package Number YZR0036AAA or

DSBGA Package, 3.0 x 3.0 x 0.65mm, 0.5mm pitch Package Number YPG0036AAA

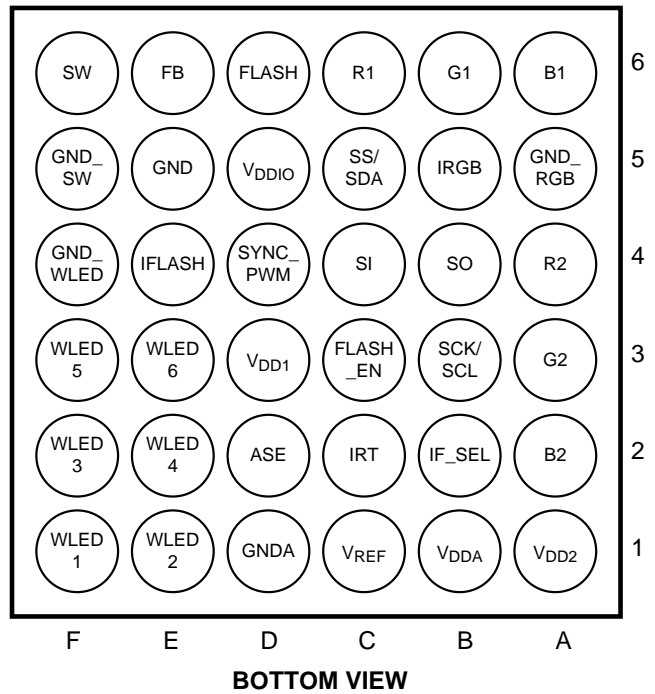
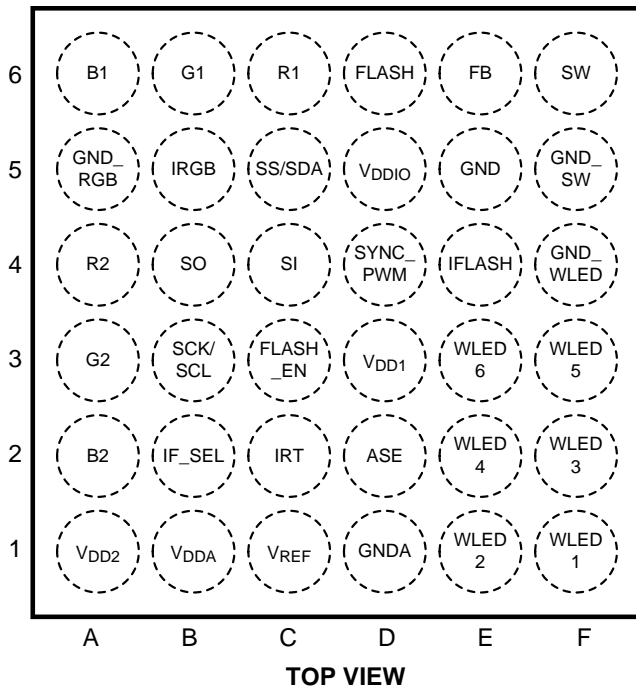

Table 1. Pin Descriptions

Pin No.	Name	Type	Description
6F	SW	Output	Boost Converter Power Switch
6E	FB	Input	Boost Converter Feedback
6D	FLASH	Output	High Current Flash Output
6C	R1	Output	Red LED 1 Output
6B	G1	Output	Green LED 1 Output
6A	B1	Output	Blue LED 1 Output
5F	GND_SW	Ground	Power Switch Ground
5E	GND	Ground	Ground
5D	VDDIO	Power	Supply Voltage for Input/output Buffers and Drivers
5C	SS/SDA	Logic Input/Output	Slave Select (SPI), Serial Data In/Out (I ² C)
5B	IRGB	Input	Bias Current Set Resistor for RGB Drivers
5A	GND_RGB	Ground	Ground for RGB Currents
4F	GND_WLED	Ground	Ground for WLED Currents
4E	IFLASH	Input	High Current Flash Current Set Resistor
4D	SYNC_PWM	Logic Input	External PWM Control for LEDs or External Clock for RGB Sync
4C	SI	Logic Input	Serial Input (SPI), Address Select (I ² C)
4B	SO	Logic Output	Serial Data Out (SPI)
4A	R2	Output	Red LED 2 output
3F	WLED5	Output	White LED 5 output
3E	WLED6	Output	White LED 6 output
3D	VDD1	Power	Supply voltage
3C	EN_FLASH	Logic Input	Enable for High Current Flash
3B	SCK/SCL	Logic Input	Clock (SPI/I ² C)
3A	G2	Output	Green LED 2 Output
2F	WLED3	Output	White LED 3 output
2E	WLED4	Output	White LED 4 output
2D	ASE	Input	Audio Synchronization Input
2C	IRT	Input	Oscillator Frequency Resistor
2B	IF_SEL	Logic Input	Interface (SPI or I ² C compatible) Selection (IF_SEL = 1 for SPI)
2A	B2	Output	Blue LED 2 Output
1F	WLED1	Output	White LED 1 Output
1E	WLED2	Output	White LED 2 Output
1D	GNDA	Ground	Ground for Analog Circuitry
1C	VREF	Output	Reference Voltage
1B	VDDA	Power	Internal LDO Output
1A	VDD2	Power	Supply Voltage



These devices have limited built-in ESD protection. The leads should be shorted together or the device placed in conductive foam during storage or handling to prevent electrostatic damage to the MOS gates.

Absolute Maximum Ratings^{(1) (2)(3)}

V (SW, FB, R1-2, G1-2, B1-2, FLASH, WLED1-6) ^{(4) (5)}	-0.3V to +7.2V
V _{DD1} , V _{DD2} , V _{DD_IO} , V _{DDA}	-0.3V to +6.0V
Voltage on ASE, IRT, IFLASH, IRGB, VREF	-0.3V to V _{DD1} +0.3V with 6.0V max
Voltage on Logic Pins	-0.3V to V _{DD_IO} +0.3V with 6.0V max
V(all other pins): Voltage to GND	-0.3V to 6.0V
I (V _{REF})	10μA
I(R1, G1, B1, R2, G2, B2)	100mA
I(FLASH) ⁽⁶⁾	400mA
Continuous Power Dissipation ⁽⁷⁾	Internally Limited
Junction Temperature (T _{J-MAX})	150°C
Storage Temperature Range	-65°C to +150°C
Maximum Lead Temperature (Soldering) ⁽⁸⁾	260°C
ESD Rating, Human Body Model ⁽⁹⁾	2kV

- (1) Absolute Maximum Ratings indicate limits beyond which damage to the component may occur. Operating Ratings are conditions under which operation of the device is ensured. Operating Ratings do not imply ensured performance limits. For ensured performance limits and associated test conditions, see the Electrical Characteristics tables.
- (2) All voltages are with respect to the potential at the GND pins.
- (3) If Military/Aerospace specified devices are required, please contact the TI Sales Office/Distributors for availability and specifications.
- (4) Battery/Charger voltage should be above 6V no more than 10% of the operational lifetime.
- (5) Voltage tolerance of LP3954 above 6.0V relies on fact that V_{DD1} and V_{DD2} (2.8V) are available (ON) at all conditions. If V_{DD1} and V_{DD2} are not available (ON) at all conditions, TI does not ensure any parameters or reliability for this device.
- (6) The total load current of the boost converter in worst-case conditions should be limited to 300mA (min. input and max. output voltage).
- (7) Internal thermal shutdown circuitry protects the device from permanent damage. Thermal shutdown engages at T_J=160°C (typ.) and disengages at T_J=140°C (typ.).
- (8) For detailed soldering specifications and information, please refer to Application Note AN1112 : Micro SMD Wafer Level Chip Scale Package [SNVA009](#) or Application Note AN1412 : Micro SMDxt Wafer Level Chip Scale Package [SNVA131](#).
- (9) The Human body model is a 100pF capacitor discharged through a 1.5kΩ resistor into each pin. The machine model is a 200pF capacitor discharged directly into each pin. MIL-STD-883 3015.7

Operating Ratings^{(1) (2)}

V (SW, FB, WLED1-6, R1-2, G1-2, B1-2, FLASH)	0 to 6.0V
V _{DD1,2} with external LDO	2.7 to 5.5V
V _{DD1,2} with internal LDO	3.0 to 5.5V
V _{DDA}	2.7 to 2.9V
V _{DD_IO}	1.65V to V _{DD1}
Voltage on ASE	0.1V to V _{DDA} -0.1V
Recommended Load Current	0mA to 300mA
Junction Temperature (T _J) Range	-30°C to +125°C
Ambient Temperature (T _A) Range ⁽³⁾	-30°C to +85°C

- (1) Absolute Maximum Ratings indicate limits beyond which damage to the component may occur. Operating Ratings are conditions under which operation of the device is ensured. Operating Ratings do not imply ensured performance limits. For ensured performance limits and associated test conditions, see the Electrical Characteristics tables.
- (2) All voltages are with respect to the potential at the GND pins.
- (3) In applications where high power dissipation and/or poor package thermal resistance is present, the maximum ambient temperature may have to be derated. Maximum ambient temperature (T_{A-MAX}) is dependent on the maximum operating junction temperature (T_{J-MAX-OP} = 125°C), the maximum power dissipation of the device in the application (P_{D-MAX}), and the junction-to ambient thermal resistance of the part/package in the application (θ_{JA}), as given by the following equation: T_{A-MAX} = T_{J-MAX-OP} - (θ_{JA} × P_{D-MAX}).

Thermal Properties

Junction-to-Ambient Thermal Resistance(θ _{JA}), YZR0036AAA or YPG0036AAA Package ⁽¹⁾	60°C/W
---	--------

- (1) Junction-to-ambient thermal resistance is highly application and board-layout dependent. In applications where high maximum power dissipation exists, special care must be paid to thermal dissipation issues in board design.

Electrical Characteristics^{(1) (2)}

Limits in standard typeface are for $T_j = 25^\circ\text{C}$. Limits in **boldface** type apply over the operating ambient temperature range ($-30^\circ\text{C} < T_A < +85^\circ\text{C}$). Unless otherwise noted, specifications apply to the LP3954 Block Diagram with: $V_{DD1} = V_{DD2} = 3.6\text{V}$, $V_{DDIO} = 2.8\text{V}$, $C_{VDD} = C_{VDDIO} = 100\text{nF}$, $C_{OUT} = C_{IN} = 10\mu\text{F}$, $C_{VDDA} = 1\mu\text{F}$, $C_{REF} = 100\text{nF}$, $L_1 = 4.7\mu\text{H}$, $R_{FLASH} = 1.2\text{k}$, $R_{RGB} = 5.6\text{k}$ and $R_{RT} = 82\text{k}$ ⁽³⁾.

Parameter		Test Conditions	Min	Typ	Max	Unit	
I_{VDD}	Standby supply current (V_{DD1}, V_{DD2})	NSTBY = L SCK, SS, SI		1	8	μA	
	No-boost supply current (V_{DD1}, V_{DD2})	NSTBY = H, EN_BOOST = L SCK, SS, SI Audio sync and LEDs OFF			400	μA	
	No-load supply current (V_{DD1}, V_{DD2})	NSTBY = H, EN_BOOST = H SCK, SS, SI Audio sync and LEDs OFF Autoload OFF			1	mA	
	RGB drivers (V_{DD1}, V_{DD2})	CC mode at R1, G1, B1 and R2, G2, B2 set to 15mA			150		μA
		SW mode			150		
	WLED drivers (V_{DD1}, V_{DD2})	4+2 banks I_{OUT}/LED 25mA			500		μA
	Audio synchronization (V_{DD1}, V_{DD2})	Audio sync ON					
$V_{DD1,2} = 2.8\text{V}$				390		μA	
$V_{DD1,2} = 3.6\text{V}$				700			
Flash (V_{DD1}, V_{DD2})	$I(R_{FLASH}) = 1\text{mA}$ Peak current during flash			2		mA	
I_{VDDIO}	V_{DDIO} Standby Supply current	NSTBY = L SCK, SS, SI = H			1	μA	
	V_{DDIO} supply current	1MHz SCK frequency in SPI mode, $C_L = 50\text{pF}$ at SO pin		20		μA	
I_{EXT_LDO}	External LDO output current ($V_{DD1}, V_{DD2}, V_{DDA}$)	7V tolerant application only $I_{BOOST} = 300\text{mA}$			6.5	mA	
V_{DDA}	Output voltage of internal LDO for analog parts	⁽⁴⁾	2.72	2.80	2.88	V	
			-3		+3	%	

- (1) All voltages are with respect to the potential at the GND pins.
- (2) Min and Max limits are ensured by design, test, or statistical analysis. Typical numbers are not ensured, but do represent the most likely norm.
- (3) Low-ESR Surface-Mount Ceramic Capacitors (MLCCs) used in setting electrical characteristics.
- (4) V_{DDA} output is not recommended for external use.

DETAILED DESCRIPTION

Block Diagram

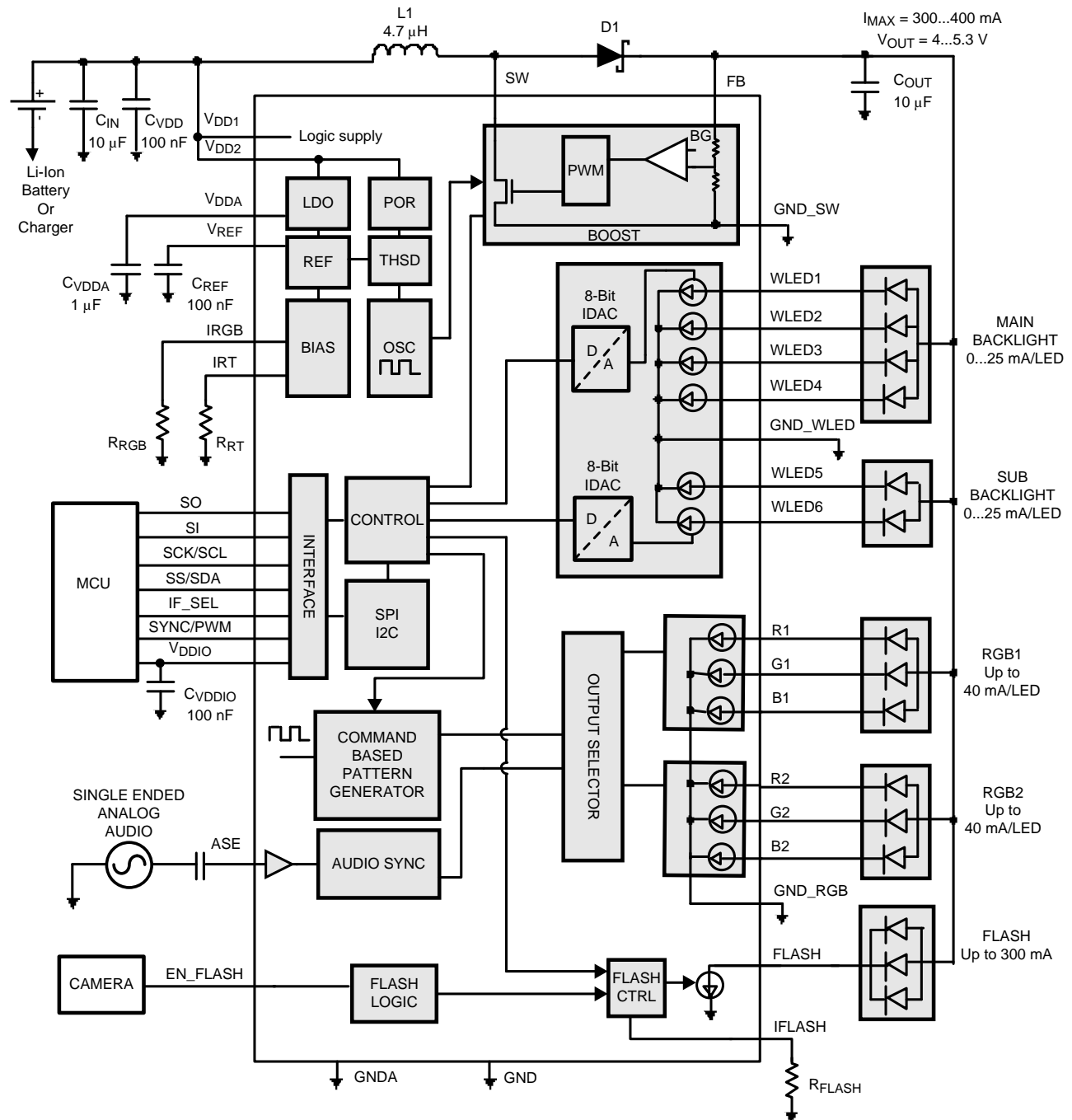

Modes of Operation

RESET: In the RESET mode all the internal registers are reset to the default values and the chip goes to STANDBY mode after reset. NSTBY control bit is low after reset by default. Reset is entered always if Reset Register is written or internal Power On Reset is active. There is no dedicated Reset pin available. LP3954 can be reset by writing any data to Reset Register in address 60H. Power On Reset (POR) will activate during the chip startup or when the supply voltage VDD2 falls below 1.5V. Once VDD2 rises above 1.5V, POR will inactivate and the chip will continue to the STANDBY mode.

STANDBY: The STANDBY mode is entered if the register bit NSTBY is LOW. This is the low power consumption mode, when all circuit functions are disabled. Registers can be written in this mode and the control bits are effective immediately after power up.

STARTUP: When NSTBY bit is written high, the INTERNAL STARTUP SEQUENCE powers up all the needed internal blocks (Vref, Bias, Oscillator etc..). To ensure the correct oscillator initialization, a 10ms delay is generated by the internal state-machine. If the chip temperature rises too high, the Thermal Shutdown (THSD) disables the chip operation and STARTUP mode is entered until no thermal shutdown event is present.

BOOST STARTUP: Soft start for boost output is generated in the BOOST STARTUP mode. The boost output is raised in PFM mode during the 10ms delay generated by the state-machine. The Boost startup is entered from Internal Startup Sequence if EN_BOOST is HIGH or from Normal mode when EN_BOOST is written HIGH. During the 10ms Boost Startup time all LED outputs are switched off to ensure smooth start-up.

NORMAL: During NORMAL mode the user controls the chip using the Control Registers. The registers can be written in any sequence and any number of bits can be altered in a register in one write

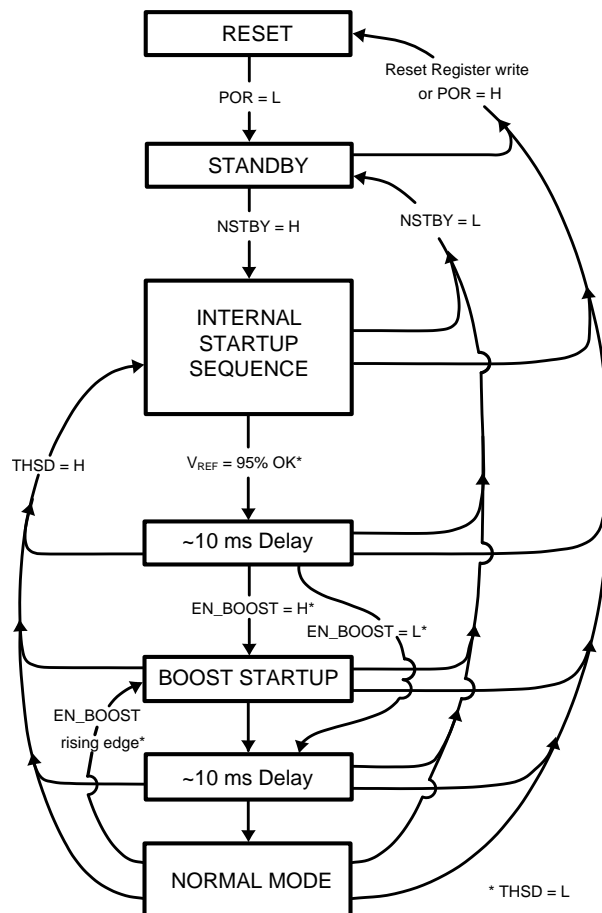

Figure 1. Modes of Operation

Magnetic Boost DC/DC Converter

The LP3954 Boost DC/DC Converter generates a 4.0 – 5.3V voltage for the LEDs from single Li-Ion battery (3V...4.5V). The output voltage is controlled with an 8-bit register in 9 steps. The converter is a magnetic switching PWM mode DC/DC converter with a current limit. The converter has three options for switching frequency, 1MHz, 1.67MHz and 2MHz (default), when timing resistor RT is 82kohm. Timing resistor defines the internal oscillator frequency and thus directly affects boost frequency and all circuit's internally generated timing (RGB, Flash, WLED fading).

The LP3954 Boost Converter uses pulse-skipping elimination to stabilize the noise spectrum. Even with light load or no load a minimum length current pulse is fed to the inductor. An active load is used to remove the excess charge from the output capacitor at very light loads. At very light load and when input and output voltages are very close to each other, the pulse skipping is not completely eliminated. Output voltage should be at least 0.5V higher than input voltage to avoid pulse skipping. Reducing the switching frequency will also reduce the required voltage difference.

Active load can be disabled with the en_autoload bit. Disabling will increase the efficiency at light loads, but the downside is that pulse skipping will occur. The Boost Converter should be stopped when there is no load to minimise the current consumption.

The topology of the magnetic boost converter is called CPM control, current programmed mode, where the inductor current is measured and controlled with the feedback. The user can program the output voltage of the boost converter. The output voltage control changes the resistor divider in the feedback loop.

The following figure shows the boost topology with the protection circuitry. Four different protection schemes are implemented:

1. Over voltage protection, limits the maximum output voltage
 - Keeps the output below breakdown voltage.
 - Prevents boost operation if battery voltage is much higher than desired output.
2. Over current protection, limits the maximum inductor current
 - Voltage over switching NMOS is monitored; too high voltages turn the switch off.
3. Feedback break protection. Prevents uncontrolled operation if FB pin gets disconnected.
4. Duty cycle limiting, done with digital control.

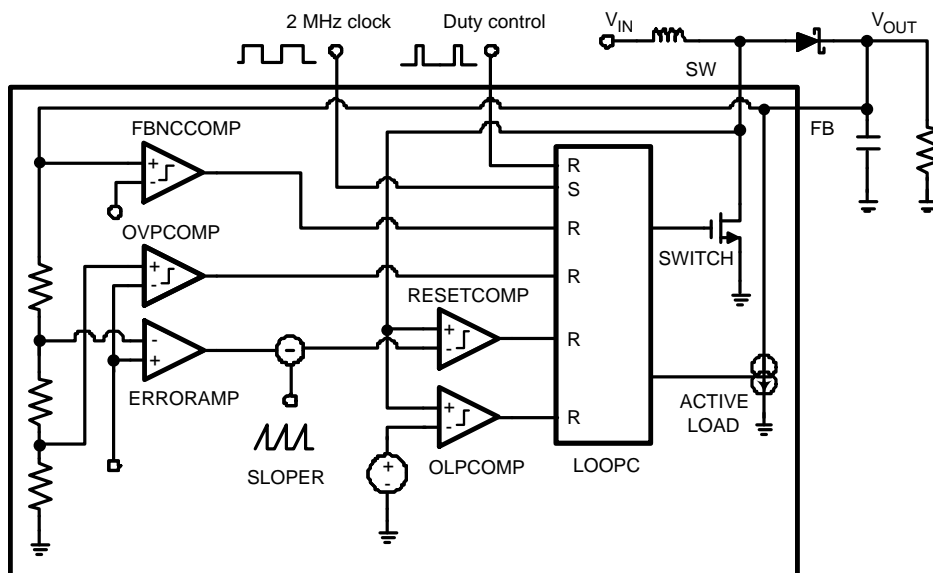

Figure 2. Boost Converter Topology

MAGNETIC BOOST DC/DC CONVERTER ELECTRICAL CHARACTERISTICS

Parameter		Test Conditions	Min	Typ	Max	Unit
I _{LOAD}	Load Current	3.0V ≤ V _{IN} V _{OUT} = 5V	0		300	mA
		3.0V ≤ V _{IN} V _{OUT} = 4V	0		400	
V _{OUT}	Output Voltage Accuracy (FB Pin)	3.0V ≤ V _{IN} ≤ V _{OUT} - 0.5 V _{OUT} = 5.0V	-5		+5	%
	Output Voltage (FB Pin)	1 mA ≤ I _{LOAD} ≤ 300 mA V _{IN} > 5V + V _(SCHOTTKY)		V _{IN} - V _(SCHOTTKY)		V
R _{DS(ON)}	Switch ON Resistance	V _{DD1,2} = 2.8V, I _{SW} = 0.5A		0.4	0.8	Ω
f _{PWF}	PWM Mode Switching Frequency	RT = 82 kΩ freq_sel[2:0] = 1XX		2		MHz
	Frequency Accuracy	2.7 ≤ V _{DDA} ≤ 2.9 RT = 82 kΩ	-6 -9	±3	+6 +9	%
t _{PULSE}	Switch Pulse Minimum Width	no load		25		ns
t _{STARTUP}	Startup Time	Boost startup from STANDBY		10		ms
I _{SW_MAX}	SW Pin Current Limit		700	800	900	mA
			550		950	

BOOST STANDBY MODE

User can stop the Boost Converter operation by writing the Enables register bit EN_BOOST low. When EN_BOOST is written high, the converter starts for 10ms in PFM mode and then goes to PWM mode.

BOOST OUTPUT VOLTAGE CONTROL

User can control the boost output voltage by boost output 8-bit register.

Boost Output [7:0] Register 0DH		Boost Output Voltage (typical)
Bin	Hex	
0000 0000	00	4.00
0000 0001	01	4.25
0000 0011	03	4.40
0000 0111	07	4.55
0000 1111	0F	4.70
0001 1111	1F	4.85
0011 1111	3F	5.00 Default
0111 1111	7F	5.15
1111 1111	FF	5.30

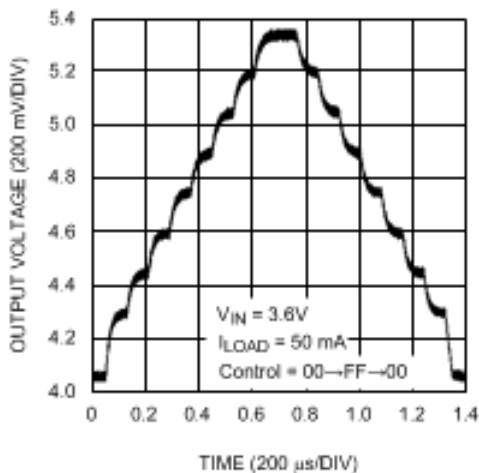

Figure 3. Boost Output Voltage Control

BOOST FREQUENCY CONTROL

freq_sel[2:0] ⁽¹⁾	frequency
1XX	2.00 MHz
01X	1.67 MHz
001	1.00 MHz

(1) Register 'boost freq' (address 0EH). Register default value after reset is 07H.

Boost Converter Typical Performance Characteristics

V_{in} = 3.6V, V_{out} = 5.0V if not otherwise stated

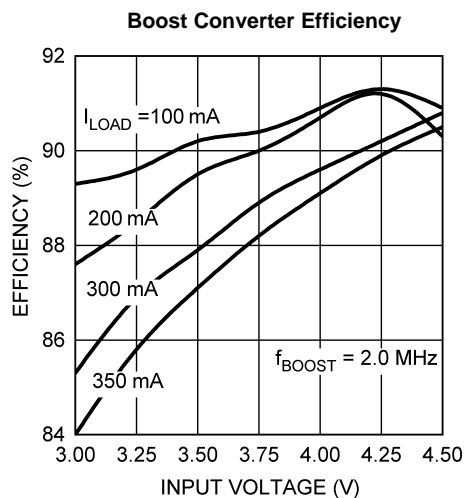

Figure 4.

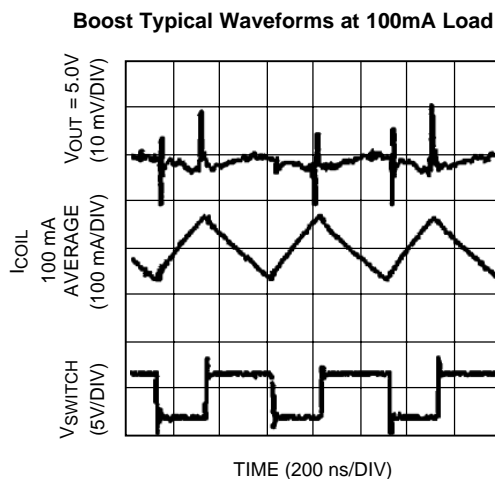

Figure 5.

V_{in} = 3.6V, V_{out} = 5.0V if not otherwise stated

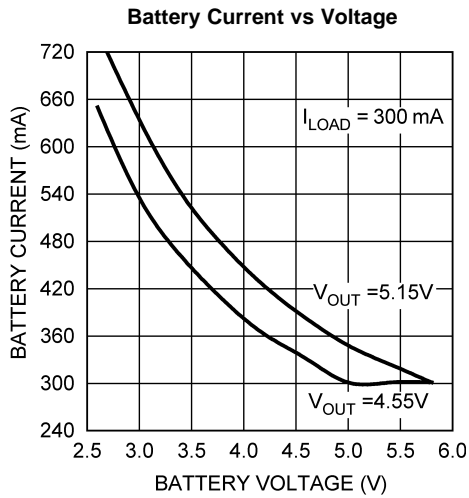

Figure 6.

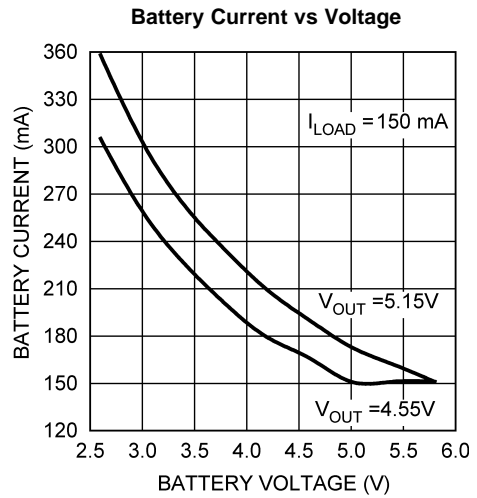

Figure 7.

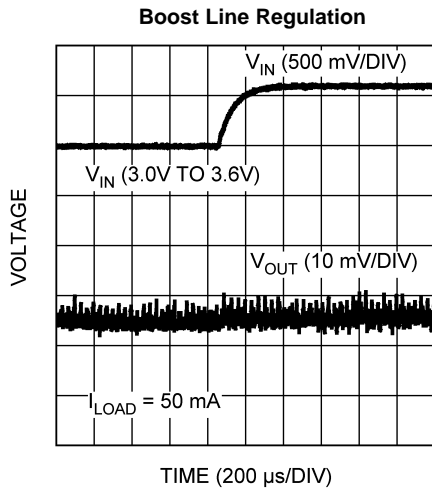

Figure 8.

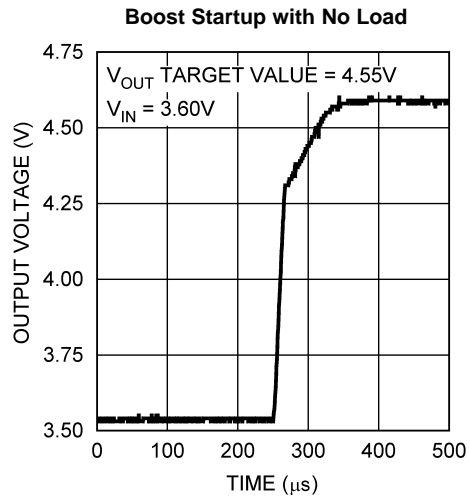

Figure 9.

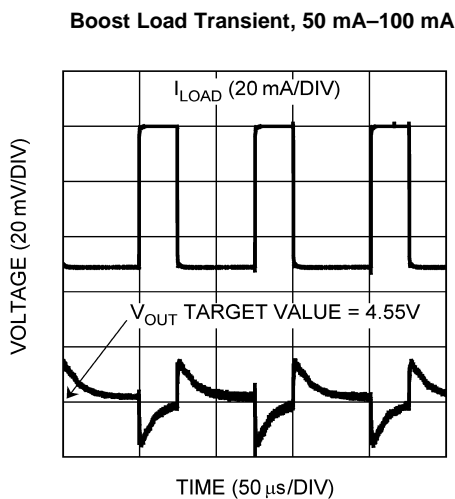

Figure 10.

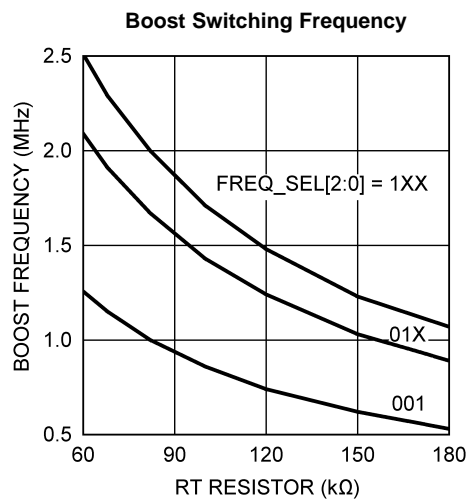

Figure 11.

V_{in} = 3.6V, V_{out} = 5.0V if not otherwise stated

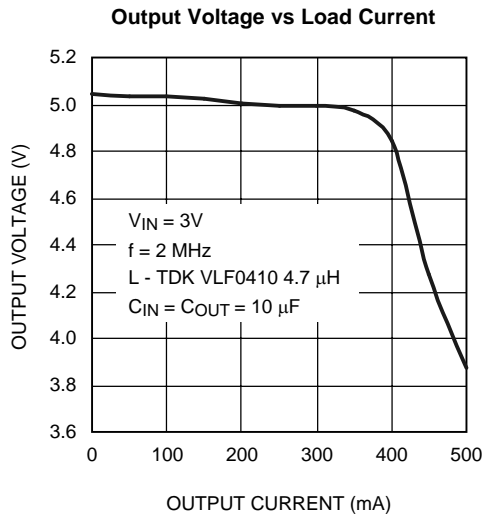

Figure 12.

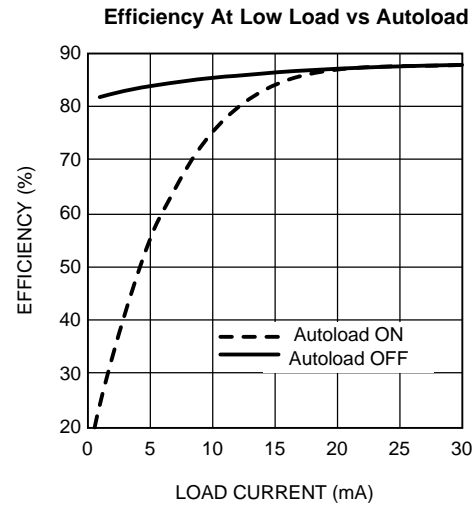

Figure 13.

Functionality of Color LED Outputs (R1, G1, B1; R2, G2, B2)

LP3954 has 2 sets of RGB/color LED outputs. Both sets have 3 outputs and the sets can be controlled in 4 different ways:

1. Command based pattern generator control (internal PWM)
2. Audio synchronization control
3. Direct ON/OFF control
4. External PWM control

By using **command based pattern generator** user can program any kind of color effect patterns. LED intensity, blinking cycles and slopes are independently controlled with 8 16-bit commands. Also real time commands are possible as well as loops and step by step control. If analog audio is available on system, the user can use **audio synchronization** for synchronizing LED blinking to the music. The different modes together with the various sub modes generate very colorful and interesting lighting effects. **Direct ON/OFF** control is mainly for switching on and off LEDs. **External PWM control** is for applications where external PWM signal is available and required to control the color LEDs. PWM signal can be connected to any color LED separately as shown later.

COLOR LED CONTROL MODE SELECTION

The RGB_SEL[1:0] bits in the Enables register (08H) control the output modes for RGB1 (R1, G1, B1) and RGB2 (R2, G2, B2) outputs. The following table shows the RGB_SEL functionality.

RGB_SEL[1:0]	Audio Sync Connected To	Command Based Pattern Generator Connected To
00	none	RGB1 & RGB2
01	RGB1	RGB2
10	RGB2	RGB1
11	RGB1 & RGB2	none

RGB Control register (00H) has control bits for direct on/off control of all color LEDs. Note that the LEDs have to be turned on in order to control them with audio synchronization or pattern generator.

The external PWM signal controls any LED depending on the control register setup. The controls are in the Ext. PWM Control register (address 07H) except the FLASH control in HC_Flash (10H) register as follows:

Ext. PWM Control ⁽¹⁾		
wled1-4_pwm	bit 7	PWM controls WLED 1-4
wled5-6_pwm	bit 6	PWM controls WLED 5-6
r1_pwm	bit 5	PWM controls R1 output
g1_pwm	bit 4	PWM controls G1 output
b1_pwm	bit 3	PWM controls B1 output
r2_pwm	bit 2	PWM controls R2 output
g2_pwm	bit 1	PWM controls G2 output
b2_pwm	bit 0	PWM controls B2 output
HC_Flash		
hc_pwm	bit 5	PWM controls high current flash

- (1) **Note:** If DISPL=1, wled1-4pwm controls WLED1-6
Note: Maximum external PWM frequency is 1kHz. If during the external PWM control the internal PWM is on the result will be product of both functions.

CURRENT CONTROL OF COLOR LED OUTPUTS (R1, R2, G1, G2, B1, B2)

Both RGB output sets can be separately controlled as constant current sinks or as switches. This is done using cc_rgb1/2 bits in the RGB control register. In constant current mode one or both RGB output sets are controlled with constant current sinks (no external ballast resistors required). The maximum output current for both drivers is set by one external resistor R_{RGB} . User can decrease the maximum current for an individual LED driver by programming as shown later.

The maximum current for all RGB drivers is set with R_{RGB} . The equation for calculating the maximum current is

$$I_{MAX} = 100 \times 1.23V / (R_{RGB} + 50\Omega) \quad (1)$$

where

I_{MAX} - maximum RGB current in any RGB output in constant current mode

1.23V - reference voltage

100 - internal current mirror multiplier

R_{RGB} - resistor value in Ohms

50Ω - internal resistor in the I_{RGB} input

For example if 22mA is required for maximum RGB current R_{RGB} equals to

$$R_{RGB} = 100 \times 1.23V / I_{MAX} - 50\Omega = 123V / 0.022A - 50\Omega = 5.54k\Omega \quad (2)$$

Each individual RGB output has a separate maximum current programming. The control bits are in registers **RGB1 max current** and **RGB2 max current** (12H and 13H) and programming is shown in table below. The default value after reset is 00.

IR1[1:0], IG1[1:0], IB1[1:0], IR2[1:0], IG2[1:0], IB2[1:0]	Maximum Current/Output
00	$0.25 \times I_{MAX}$
01	$0.50 \times I_{MAX}$
10	$0.75 \times I_{MAX}$
11	$1.00 \times I_{MAX}$

SWITCH MODE

The switch mode is used if there is a need to connect parallel LEDs to output or if the RGB output current needs to be increased.

Please note that the switch mode **requires an external ballast resistors** at each output to limit the LED current.

The switch/current mode and on/off controls for RGB are in the RGB_ctrl register (00H) as follows:

Table 2. RGB_ctrl Register (00H)

CC_RGB1	bit7	1	R1, G1 and B1 are switches → limit current with ballast resistor
		0	R1, G1 and B1 are constant current sinks, current limited internally
CC_RGB2	bit6	1	R2, G2 and B2 are switches → limit current with ballast resistor
		0	R2, G2 and B2 are constant current sinks, current limited internally
r1sw	bit5	1	R1 is on
		0	R1 is off
g1sw	bit4	1	G1 is on
		0	G1 is off
b1sw	bit3	1	B1 is on
		0	B1 is off
r2sw	bit2	1	R2 is on
		0	R2 is off
g2sw	bit1	1	G2 is on
		0	G2 is off
b2sw	bit0	1	B2 is on
		0	B2 is off

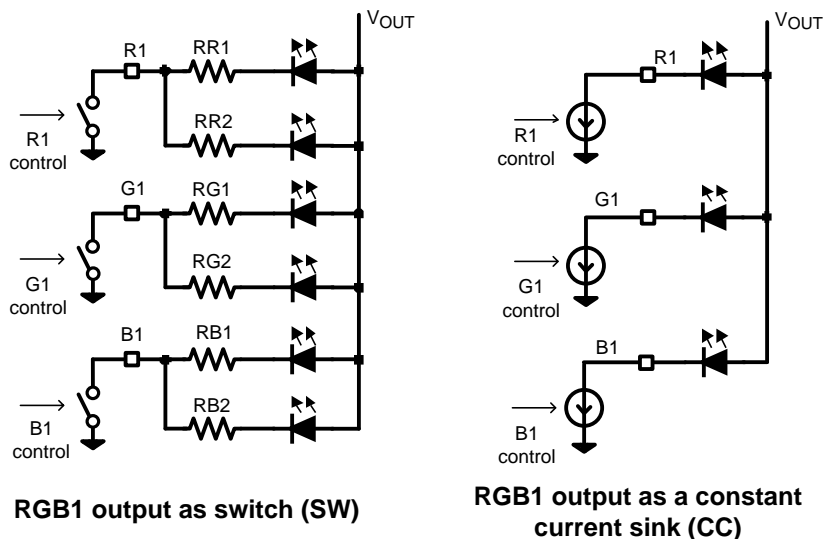

Command Based Pattern Generator for Color LEDs

The LP3954 has a unique stand-alone command based pattern generator with 8 user controllable 16-bit wide commands. Since write registers are 8-bit long one command requires 2 write cycles. Each command has intensity level for each LED, command execution time (CET) and transition time (TT). The command structure is shown in following two figures.

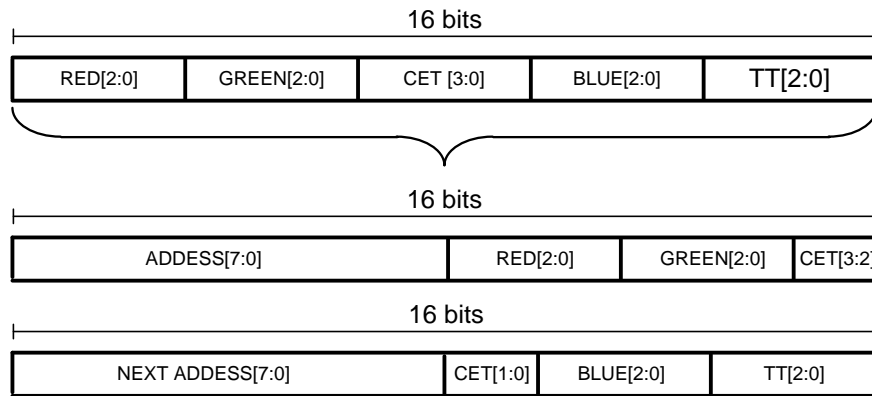

COMMAND REGISTER WITH 8 COMMANDS

COMMAND 1	ADDRESS 50H	R2	R1	R0	G2	G1	G0	CET3	CET2
	ADDRESS 51H	CET1	CET0	B2	B1	B0	TT2	TT1	TT0
COMMAND 2	ADDRESS 52H	R2	R1	R0	G2	G1	G0	CET3	CET2
	ADDRESS 53H	CET1	CET0	B2	B1	B0	TT2	TT1	TT0
COMMAND 3	ADDRESS 54H	R2	R1	R0	G2	G1	G0	CET3	CET2
	ADDRESS 55H	CET1	CET0	B2	B1	B0	TT2	TT1	TT0
COMMAND 4	ADDRESS 56H	R2	R1	R0	G2	G1	G0	CET3	CET2
	ADDRESS 57H	CET1	CET0	B2	B1	B0	TT2	TT1	TT0
COMMAND 5	ADDRESS 58H	R2	R1	R0	G2	G1	G0	CET3	CET2
	ADDRESS 59H	CET1	CET0	B2	B1	B0	TT2	TT1	TT0
COMMAND 6	ADDRESS 5AH	R2	R1	R0	G2	G1	G0	CET3	CET2
	ADDRESS 5BH	CET1	CET0	B2	B1	B0	TT2	TT1	TT0
COMMAND 7	ADDRESS 5CH	R2	R1	R0	G2	G1	G0	CET3	CET2
	ADDRESS 5DH	CET1	CET0	B2	B1	B0	TT2	TT1	TT0
COMMAND 8	ADDRESS 5EH	R2	R1	R0	G2	G1	G0	CET3	CET2
	ADDRESS 5FH	CET1	CET0	B2	B1	B0	TT2	TT1	TT0

COLOR INTENSITY CONTROL

Each color, Red, Green and Blue, has 3-bit intensity levels. The level control is logarithmic. 2 logarithmic curves are available. The LOG bit in Pattern_gen_ctrl register (11H) defines the curve used. The values for both logarithmic curves are shown in following table.

R[2:0], G[2:0], B[2:0]	CURRENT [% × I _{MAX(COLOR)}]	
	LOG=0	LOG=1
000	0	0
001	7	1
010	14	2
011	21	4
100	32	10
101	46	21
110	71	46
111	100	100

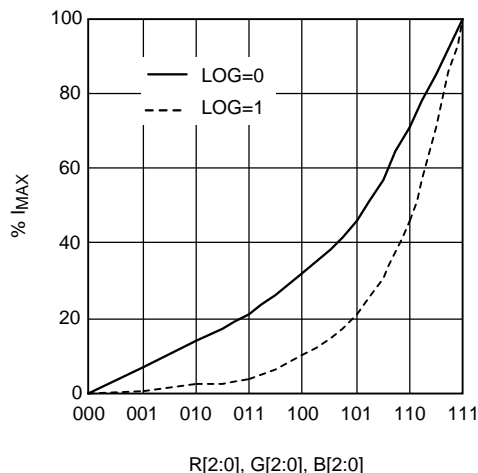

COMMAND EXECUTION TIME (CET) AND TRANSITION TIME (TT)

The command execution CET time is the duration of one single command. Command execution times CET are defined as follows, when $R_T=82k$:

CET [3:0]	CET duration, ms
0000	197
0001	393
0010	590
0011	786
0100	983
0101	1180
0110	1376
0111	1573
1000	1769
1001	1966
1010	2163
1011	2359
1100	2556
1101	2753
1110	2949
1111	3146

Transition time TT is duration of transition from the previous RGB value to programmed new value. Transition times TT are defined as follows:

TT [2:0]	Transition time, ms
000	0
001	55
010	110
011	221
100	442
101	885
110	1770
111	3539

The figure below shows an example of RGB CET and TT times.

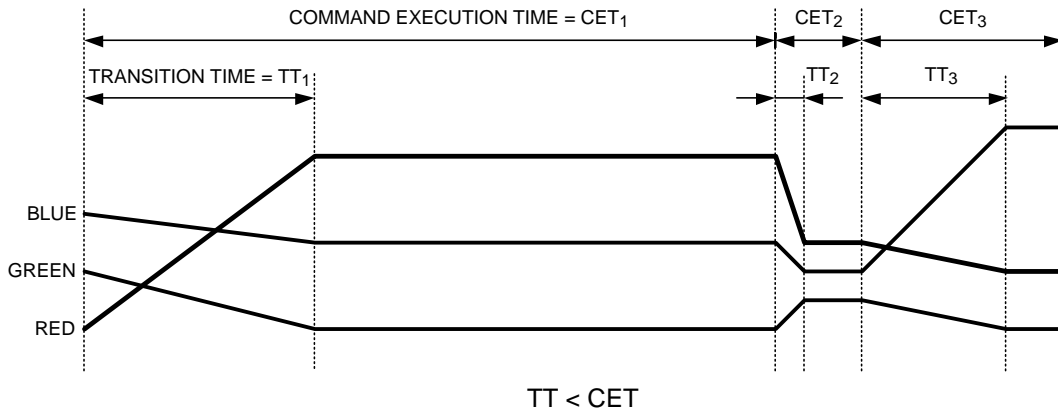

The command execution time also may be less than the transition time – the figure below illuminates this case.

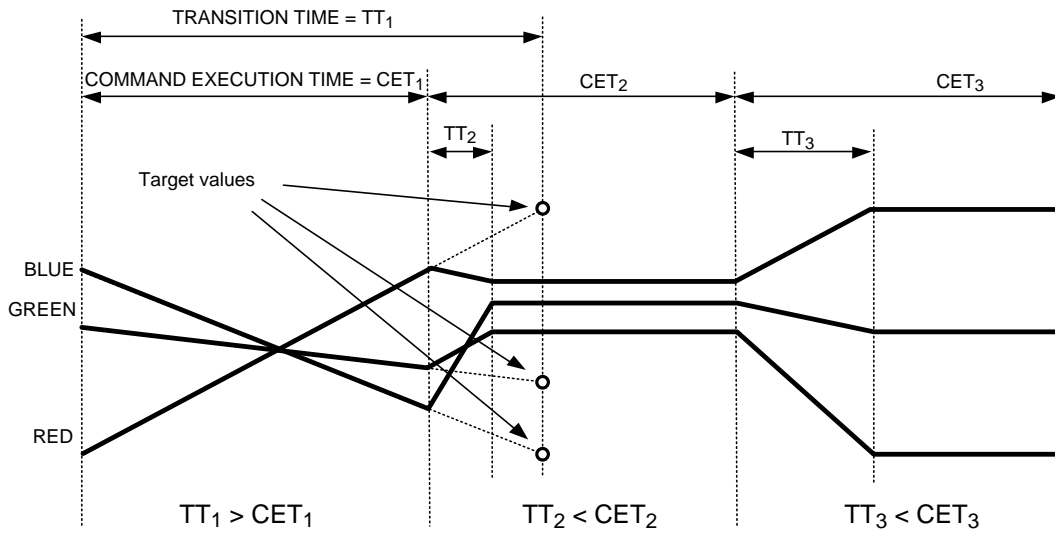

LOOP CONTROL

Pattern generator commands can be looped using the LOOP bit (D1) in Pattern gen ctrl register (11H). If LOOP=1 the program will be looped from the command 8 register or if there is 0000 0000 and 0000 0000 in one command register. The loop will start from command 1 and continue until stopped by writing rgb_start=0 or loop=0. The example of loop is shown in following figure:

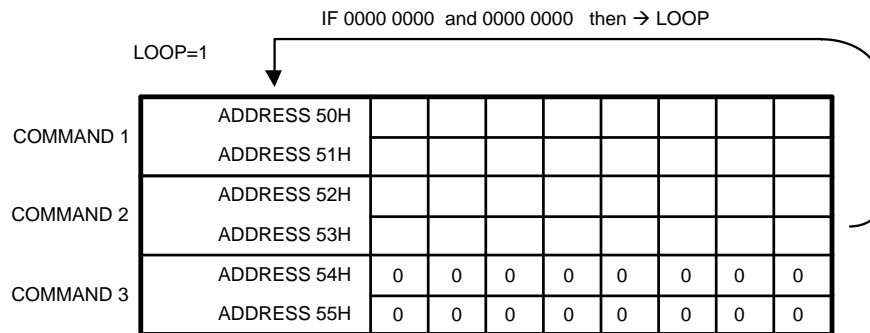

SINGLE PROGRAM

If control bit LOOP=0 the program will start from Command 1 and run to either last command or to empty “0000 0000 / 0000 0000” command.

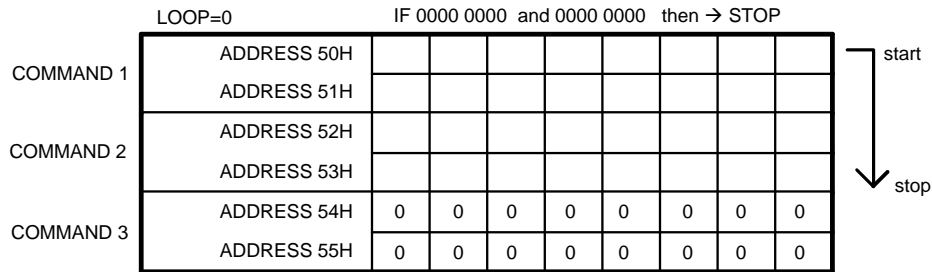

The LEDs maintain the brightness of the last command when the single program stops. Changes in command register will not be effective in this phase. The RGB_START bit has to be toggled off and on to make changes effective.

START BIT

Pattern_gen_ctrl register’s RGB_START bit will enable command execution starting from Command 1.

Pattern gen ctrl register (11H)		
rgb_start	Bit 2	0 – Pattern generator disabled 1 – execution pattern starting from command 1
loop	Bit 1	0 – pattern generator loop disabled (single pattern) 1 – pattern generator loop enabled (execute until stopped)
log	Bit 0	0 – color intensity mode 0 1 – color intensity mode 1

HARDWARE ON/OFF CONTROL AND DIMMING

PWM_LED input can be used as direct ON/OFF control or PWM dimming control for selected RGB outputs or the WLED groups. PWM_LED control can be enabled with the control bits in the **Ext. PWM Control** register.

Audio Synchronization

The color LEDs connected to RGB outputs can be synchronized to incoming audio with Audio Synchronization feature. Audio Sync has 2 modes. **Amplitude mode** synchronizes color LEDs based on input signal’s peak amplitude. In the amplitude mode the user can select between 3 different amplitude mapping modes and 4 different speed configurations. The **frequency mode** synchronizes the color LEDs based on bass, middle and treble amplitudes (= low pass, band pass and high pass filters). User can select between 2 different frequency responses and 4 different speed configurations for best audio-visual user experience. Programmable gain and AGC function are also available for adjustment of input signal amplitude to light response. The Audio Sync functionality is described more closely below.

USING A DIGITAL PWM AUDIO SIGNAL AS AN AUDIO SYNCHRONIZATION SOURCE

If the input signal is a PWM signal, use a first or second order low pass filter to convert the digital PWM audio signal into an analog waveform. There are two parameters that need to be known to get the filter to work successfully: frequency of the PWM signal and the voltage level of the PWM signal. Suggested cut-off frequency (-3dB) should be around 2 kHz to 4 kHz and the stop-band attenuation at sampling frequency should be around -48dB or better. Use a resistor divider to reduce the digital signal amplitude to meet the specification of the analog audio input. Because a low-order low-pass filter attenuates the high-frequency components from audio signal, MODE_CONTROL=[01] selection is recommended when frequency synchronization mode is enabled. Application example 5 shows an example of a second order RC-filter for 29 kHz PWM signal with 3.3V amplitude. Active filters, such as a Sallen-Key filter, may also be applied. An active filter gives better stop-band attenuation and cut-off frequency can be higher than for a RC-filter.

To make sure that the filter rolls off sufficiently quickly, connect your filter circuit to the audio input(s), turn on the audio synchronization feature, set manual gain to maximum, apply the PWM signal to the filter input and keep an eye on LEDs. If they are blinking without an audio signal (modulation), a sharper roll-off after the cut-off frequency, more stop-band attenuation, or smaller amplitude of the PWM signal is required.

AUDIO SYNCHRONIZATION SIGNAL PATH

LP3954 audio synchronization is mainly done digitally and it consists of the following signal path blocks:

- Input Buffers
- AD Converter
- DC Remover
- Automatic Gain Control (AGC)
- Programmable Gain
- 3 Band Digital Filter
- Peak Detector
- Look-up Tables (LUT)
- Mode Selector
- Integrators
- PWM Generator
- Output Drivers

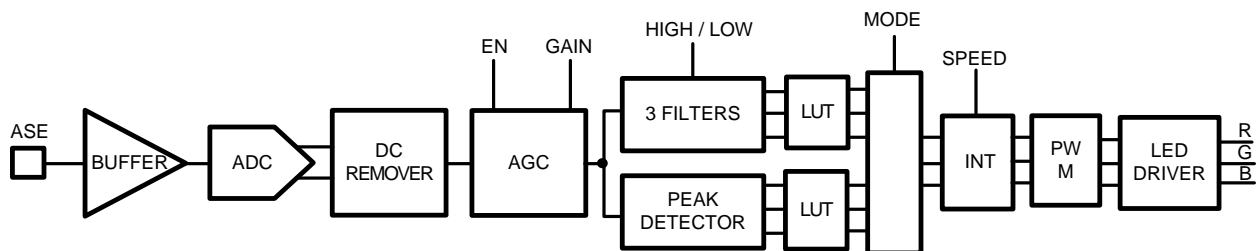

The digitized input signal has DC component that is removed by digital **DC REMOVER** (-3dB at 400Hz). Since the light response of input audio signal is very much amplitude dependent the AGC adjusts the input signal to suitable range automatically. User can disable **AGC** and the gain can be set manually with **PROGRAMMABLE GAIN**. LP3954 has 2 audio synchronization modes: amplitude and frequency. For amplitude based synchronization the **PEAK DETECTION** method is used. For frequency based synchronization **3 BAND FILTER** separates high pass, low pass and band pass signals. For both modes the predefined LUT is used to optimize the audio visual effect. **MODE SELECTOR** selects the synchronization mode. Different response times to music beat can be selected using **INTEGRATOR** speed variables. Finally **PWM GENERATOR** sets the driver FET duty cycles.

INPUT SIGNAL TYPE AND BUFFERING

LP3954 supports single ended audio input as shown in the figure below. The electric parameters of the buffer are described in the Audio Synch table. The buffer is rail-to-rail input operational amplifier connected as a voltage follower. DC level of the input signal is set by a simple resistor divider

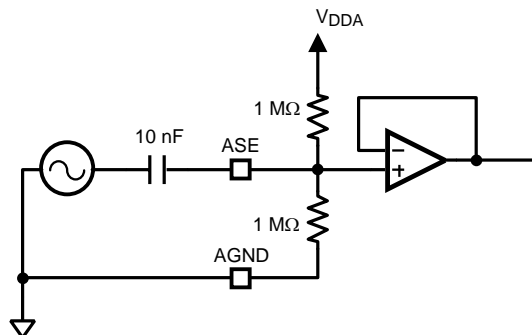

AUDIO SYNC ELECTRICAL PARAMETERS

Symbol	Parameter	Test Conditions	Min	Typ	Max	Unit
Z_{IN}	Input Impedance of ASE		250	500		kOhm
A_{IN}	Audio Input Level Range (peak-to-peak)	Gain = 21dB	0.1		$V_{DDA} - 0.1$	V
		Gain = 0 dB				
f_{3dB}	Crossover Frequencies (-3 dB)	Low Pass		0.5		kHz
		Band Pass		1.0 and 1.5		
		High Pass		2.0		
	Wide Frequency Response	Low Pass		1.0		
		Band Pass		2.0 and 3.0		
		High Pass		4.0		

CONTROL OF AUDIO SYNCHRONIZATION

The following table describes the controls required for audio synchronization.

Audio_sync_CTRL1 (2AH)			
GAIN_SEL[2:0]	Bits 7-5	Input signal gain control. Range 0...21 dB, step 3 dB: [000] = 0 dB (default) [011] = 9 dB [110] = 18 dB [001] = 3 dB [100] = 12 dB [111] = 21 dB [010] = 6 dB [101] = 15 dB	
		SYNC_MODE	Bit 4 Synchronization mode selector. SYNCMODE = 0 → Amplitude Mode (default) SYNCMODE = 1 → Frequency Mode
		EN_AGC	Bit 3 Automatic Gain Control enable 1 = enabled 0 = disabled (Gain Select enabled) (default)
		EN_SYNC	Bit 2 Audio synchronization enable 1 = Enabled Note : If AGC is enabled, AGC gain starts from current GAIN_SEL gain value. 0 = Disabled (default)
INPUT_SEL[1:0]	Bits 1-0	[00] = Single ended input signal, ASE. [01] = Temperature measurement [10] = Ambient light measurement [11] = No input (default)	
Audio_sync_CTRL2 (2BH)			
EN_AVG	Bit 4	0 – average disabled (not applicable in audio synchronization mode) 1 – average enabled (not applicable in audio synchronization mode)	
MODE_CTRL[1:0]	Bits 3-2	See below: Mode control	
SPEED_CTRL[1:0]	Bits 1-0	Sets the LEDs light response time to audio input. [00] = FASTEST (default) [01] = FAST [10] = MEDIUM [11] = SLOW (For SLOW setting in amplitude mode $f_{MAX}=3.8\text{Hz}$, Frequency mode $f_{MAX}=7.6\text{Hz}$)	

MODE CONTROL IN FREQUENCY MODE

Mode control has two setups based on audio synchronization mode select: the frequency mode and the amplitude mode. During the **frequency mode** user can select two filter options by MODE_CTRL as shown below. User can select the filters based on the music type and light effect requirements. In the first mode the frequency range extends to 8 kHz in the second to 4 kHz.

The lowpass filter is used for the red, the bandpass filter for the blue and the hipass filter for the green LED.

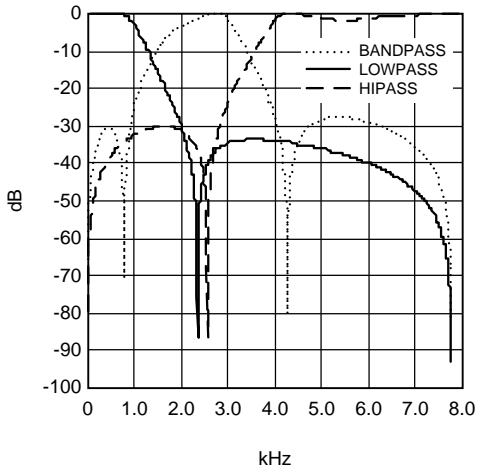

Figure 14. Higher frequency mode
MODE_CTRL = 00 and SYNC_MODE = 1

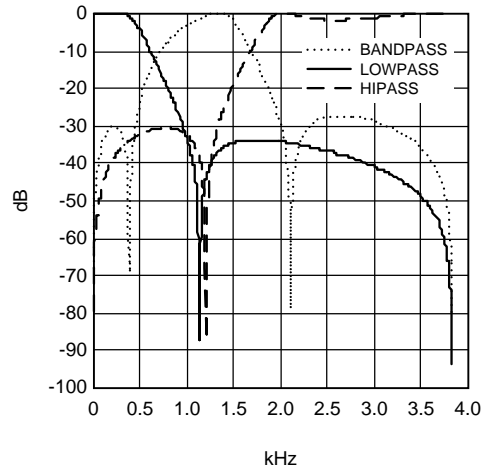

Figure 15. Lower frequency mode
MODE_CTRL = 01 and SYNC_MODE = 1

MODE CONTROL IN AMPLITUDE MODE

During the **amplitude synchronization mode** user can select between three different amplitude mappings by using MODE_CTRL select. These three mapping option gives different light response. The modes are shown in the tables below.

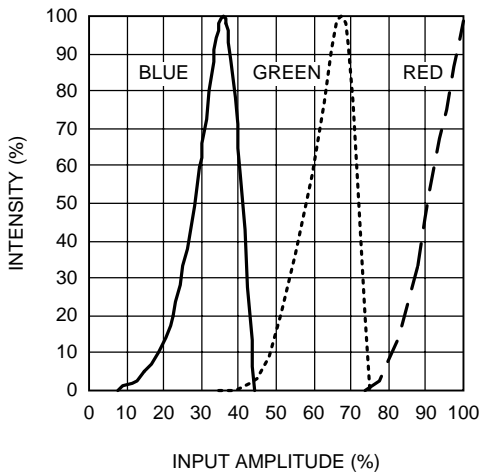

Figure 16. Non-overlapping mode
MODE_CTRL[1:0] = [01]

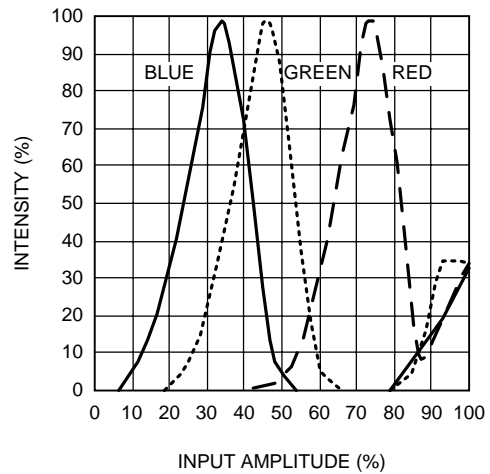

Figure 17. Partly overlapping mode
MODE_CTRL[1:0] = [00]

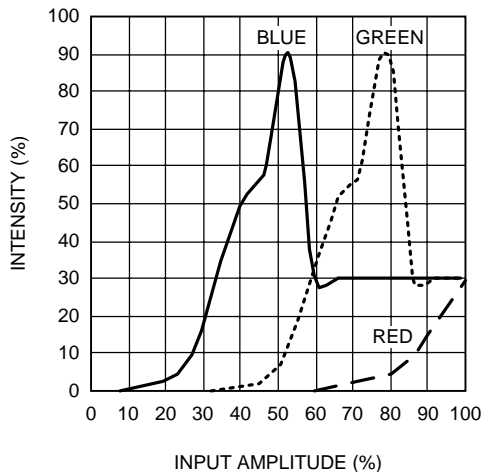

Figure 18. Overlapping mode MODE_CTRL[1:0] = [10]

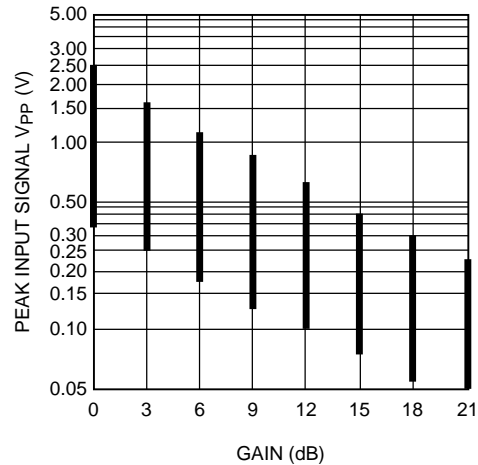

Figure 19. Peak Input Signal Level Range vs Gain Setting

RGB OUTPUT SYNCHRONIZATION TO EXTERNAL CLOCK

The RGB pattern generator and high current flash driver timing can be synchronized to external clock with following configuration.

1. Set PWM_SYNC bit in Enables register to 1
2. Feed PWM_SYNC pin with 5 MHz clock

By this the internal 5 MHz clock is disabled from pattern generator and flash timing circuitry.

The external clock signal frequency will fully determine the timings related to RGB and Flash.

Note: The boost converter will use internal 5 MHz clock even if the external clock is available.

RGB Driver Typical Performance Characteristics

RGB DRIVER ELECTRICAL CHARACTERISTICS (R1, G1, B1, R2, G2, B2 OUTPUTS)

Parameter	Test Conditions	Min	Typ	Max	Unit	
$I_{LEAKAGE}$	R1, G1, B1, R2, G2, B2 pin leakage current		0.1	1	μA	
$I_{MAX(RGB)}$	Maximum recommended sink current ⁽¹⁾	CC mode		40	mA	
		SW mode		50	mA	
	Accuracy at 37mA	$R_{RGB}=3.3\text{ k}\Omega \pm 1\%$, CC mode		± 5	%	
	Current mirror ratio	CC mode		1:100		
	RGB1 and RGB2 current mismatch	$I_{RGB}=37\text{mA}$, CC mode		± 5	%	
R_{SW}	Switch resistance	SW mode	2.5	4	Ω	
f_{RGB}	RGB switching frequency	Accuracy proportional to internal clock freq.	18.2	20	21.8	kHz
		If external SYNC 5MHz is in use		20		kHz

- (1) **Note:** RGB current should be limited as follows:
constant current mode – limit by external R_{RGB} resistor;
switch mode – limit by external ballast resistors

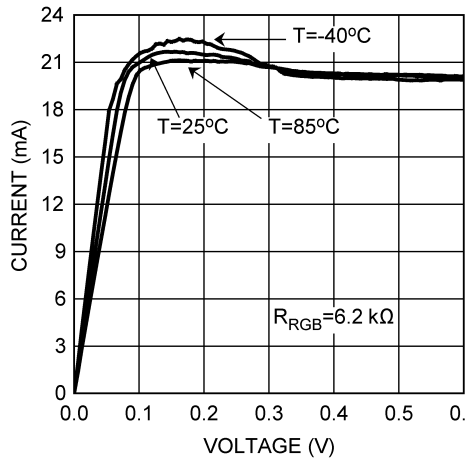

Figure 20. Output Current vs Pin Voltage (Current Sink Mode)

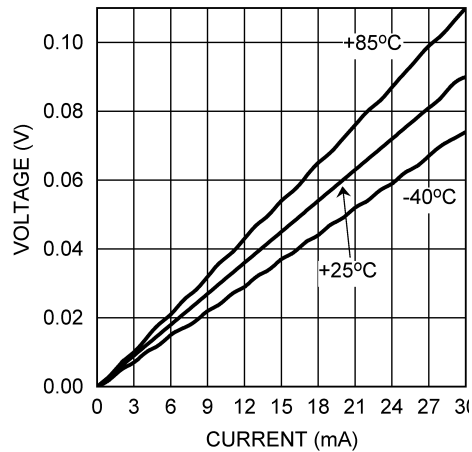

Figure 21. Pin Voltage vs Output Current (Switch Mode)

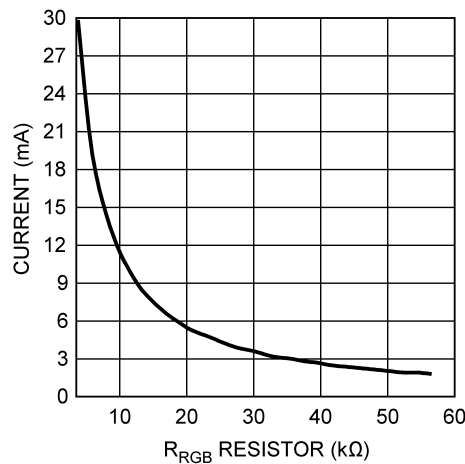

Figure 22. Output Current vs R_{RGB} (Current Sink Mode)

Single High Current Driver

LP3954 has internal constant current driver that is capable for driving high current mainly targeted for FLASH LED in camera phone applications.

MAXIMUM CURRENT SETUP FOR FLASH

The user sets the maximum current of FLASH with R_{FLASH} resistor based on following equation:

$$I_{MAX} = 300 \times 1.23V / (R_{FLASH} + 50\Omega), \tag{3}$$

where

I_{max} = maximum flash current in Amps (ie. 0.3A)

1.23V = reference voltage

300 = internal current mirror multiplier

R_{FLASH} = Resistor value in Ohms

50Ω = Internal resistor in the I_{FLASH} input

For example if 300mA is required for maximum flash current R_{FLASH} equals to

$$R_{FLASH} = 300 \times 1.23V / I_{MAX} - 50\Omega = 369V / 0.3A - 50\Omega = 1.18k\Omega \tag{4}$$

Figure 24 shows the functionality of the built-in flash.

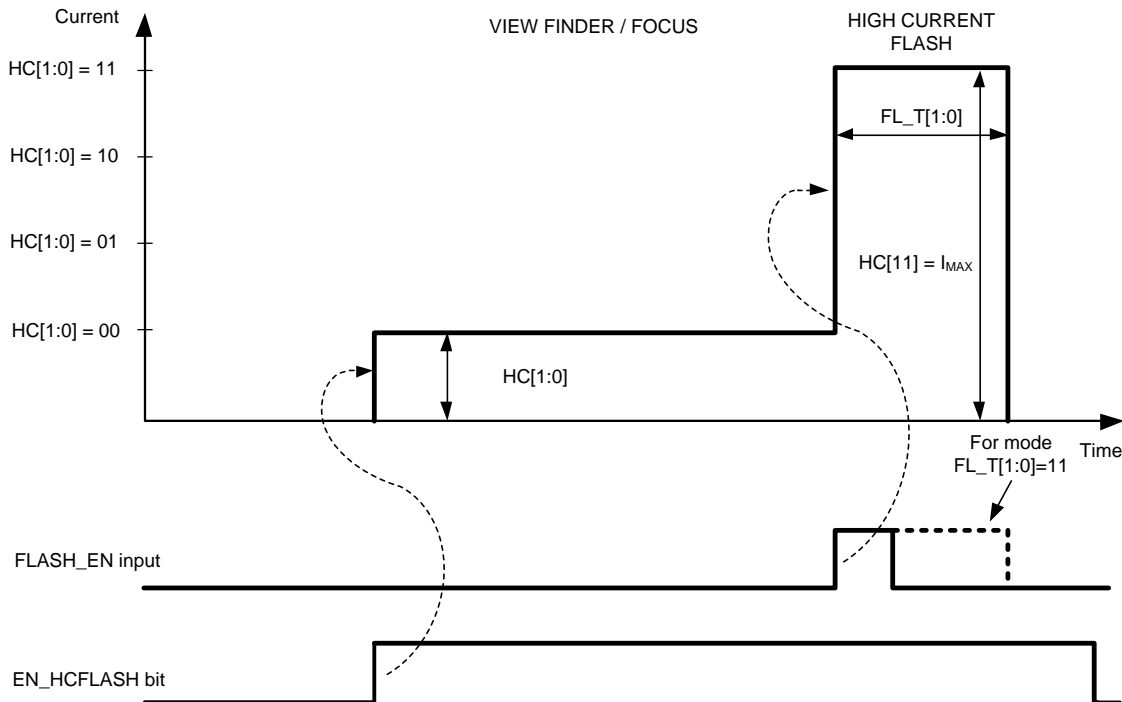

Figure 24. Built-In Flash

HIGH CURRENT DRIVER ELECTRICAL CHARACTERISTICS

Parameter	Test Conditions	Min	Typ	Max	Unit
I _{LEAKAGE}	FLASH pin leakage current		0.1	2	μA
I _{MAX(FLASH)}	Maximum Sink Current			400	mA
	Accuracy at 300 mA	R _{FLASH} =1.18 kΩ ±1%		±5	%
	Current mirror ratio		1:300		

Backlight Drivers

LP3954 has 2 independent backlight drivers. Both drivers are regulated constant current sinks. LED current for both LED banks (WLED1...4 and WLED5...6) are controlled by 8-bit current mode DACs with 0.1 mA step.

WLED1...4 and WLED5...6 can be also controlled with one DAC for better matching allowing the use of larger displays having up to 6 white LEDs in parallel.

Display configuration is controlled with DISPL bit as shown below.

DISPL	Configuration	Matching
0	Main display up to 4 LEDs	Good btw WLED1...4
	Sub display up to 2 LEDs	Good btw WLED5...6
1	Large display up to 6 LEDs	Good btw WLED 1...6

Display backlight enables		
EN_W1-4	1	WLED1-4 enabled
	0	WLED1-4 disabled
EN_W5-6	1	WLED5-6 enabled
	0	WLED5-6 disabled

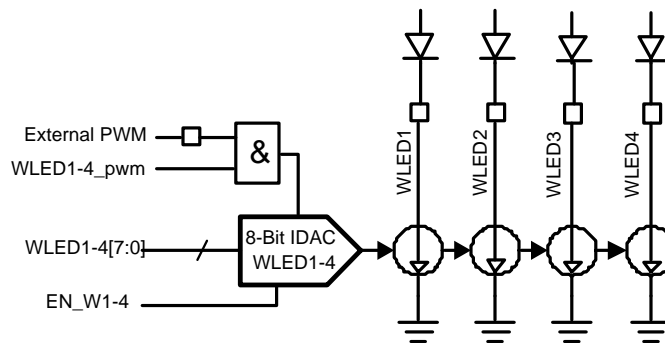

Figure 25. Main Display up to 4 LEDs (WLED1...4)

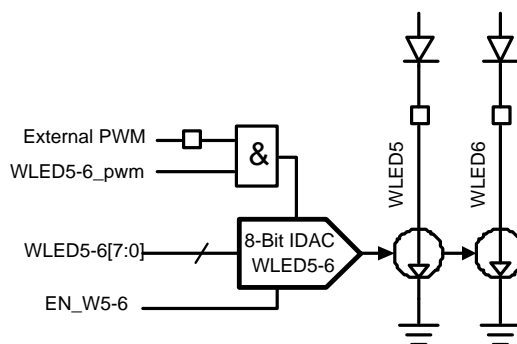

Figure 26. Sub Display Driver up to 2 LEDs (WLED5...6)

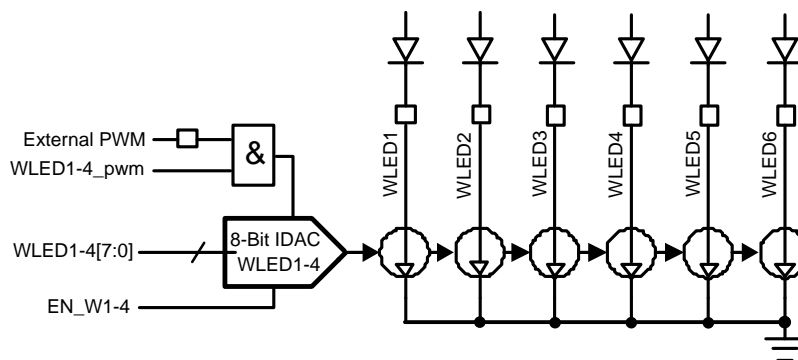

Figure 27. Main Display up to 6 LEDs (WLED1...6) (DISPL=1)

BACKLIGHT DRIVER ELECTRICAL CHARACTERISTICS

Parameter	Test Conditions	Min	Typical	Max	Unit
I_{MAX}	Maximum Sink Current	21.3	25.5	29.4	mA
$I_{Leakage}$	Leakage Current	$V_{FB} = 5V$		1	μA
I_{WLED1}	WLED1 Current tolerance	I_{WLED1} set to 12.8mA (80H)		14.78	mA
				+16	%
$I_{Match1-4}$	Sink Current Matching	$I_{SINK} = 13mA$, Between WLED1...4		0.2	%
$I_{Match5-6}$	Sink Current Matching	$I_{SINK} = 13mA$, Between WLED5...6		0.2	%
$I_{Match1-6}$	Sink Current Matching	$I_{SINK} = 13mA$, Between WLED1...6		0.3	%

ADJUSTMENT

WLED1-4[7:0] WLED5-6[7:0]	Driver Current, mA (typical)
0000 0000	0
0000 0001	0.1
0000 0010	0.2
0000 0011	0.3
...	...
...	...
1111 1101	25.3
1111 1110	25.4
1111 1111	25.5

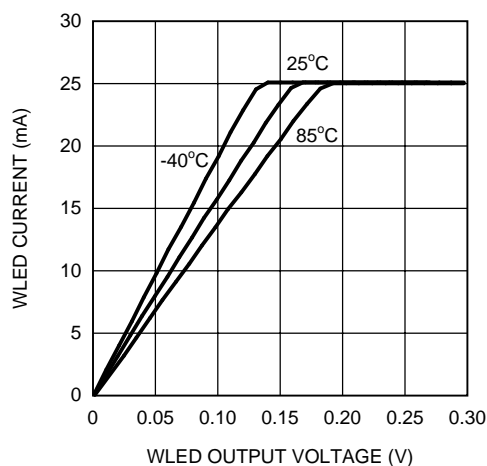

Figure 28. WLED Output Current vs. Voltage

FADE IN / FADE OUT

LP3954 has an automatic fade in and out for main and sub backlight. The fade function is enabled with EN_FADE bit. The slope of the fade curve is set by the SLOPE bit. Fade control for main and sub display is set by FADE_SEL bit.

EN_FADE	0	Automatic fade disabled
	1	Automatic fade enabled
SLOPE	0	Fade execution time 1.3s
	1	Fade execution time 0.65s
FADE_SEL	0	Fade controls WLED1-4
	1	Fade controls WLED5-6

Recommended fading sequence:

1. ASSUMPTION: Current WLED value in register
2. Set SLOPE
3. Set FADE_SEL
4. Set EN_FADE = 1
5. Set target WLED value
6. Fading will be done either within 0.5s or 1s based on Slope selection

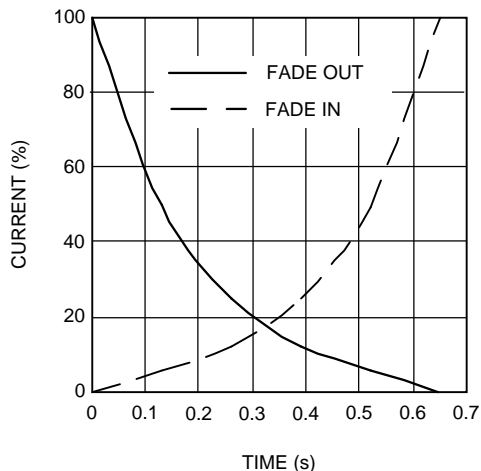

Figure 29. WLED Dimming, SLOPE=0

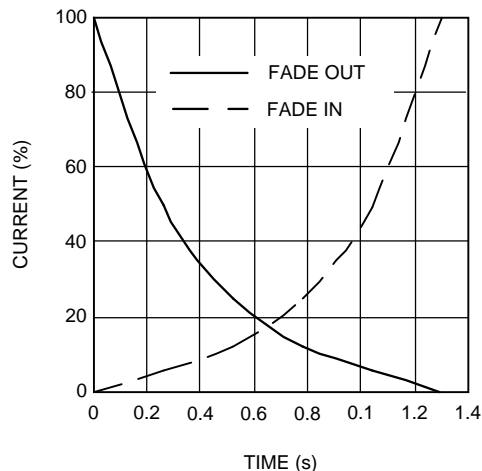

Figure 30. WLED Dimming, SLOPE=1

Ambient Light and Temperature Measurement with LP3954

The Analog-to-Digital converter (ADC) in the Audio Synchronization block can be also used for ambient light measurement or temperature measurement.

The selection between these modes is controlled with input selector bits INPUT_SEL[1:0] as follows

INPUT_SEL[1:0]	Mode
00	Audio synchronization
01	Temperature measurement (voltage input)
10	Ambient light measurement (current input)
11	No input

AMBIENT LIGHT MEASUREMENT

The ambient light measurement requires only one external component: Ambient light sensor (photo transistor or diode). The ADC reads the current level at ASE pin and converts the result in digital word. User can read the ADC output from the ADC output register. The known ambient light condition allows user to set the backlight current to optimal level thus saving power especially in low light and bright sunlight condition.

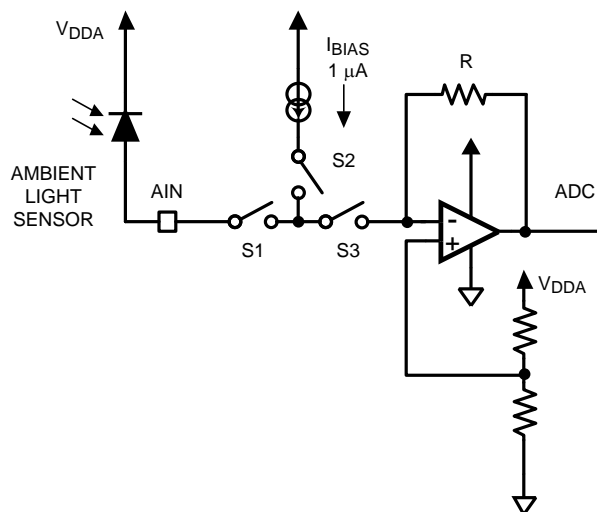

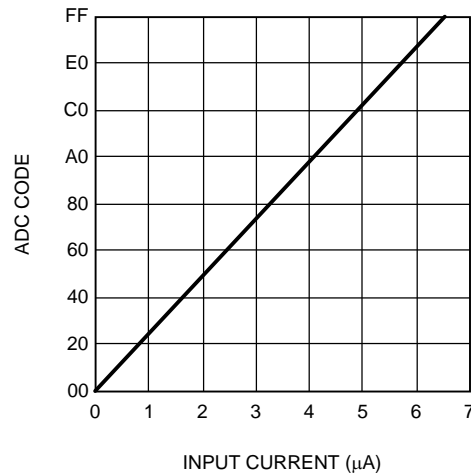

Figure 31. ADC Code vs Input Current in Light Measurement Mode

TEMPERATURE MEASUREMENT

The temperature measurement requires two external components: resistor and thermistor (resistor that has known temperature vs resistance curve). The ADC reads the voltage level at ASE pin and converts the result in digital word. User can read the ADC output from register. The known temperature allows for example to monitor the temperature inside the display module and decrease the current level of the LEDs if temperature raises too high. This function may increase lifetime of LEDs in some applications.

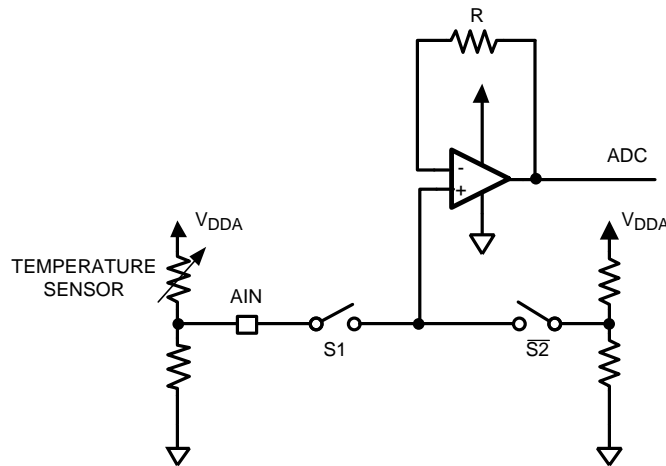

Figure 32. Temperature Sensor Connection Example

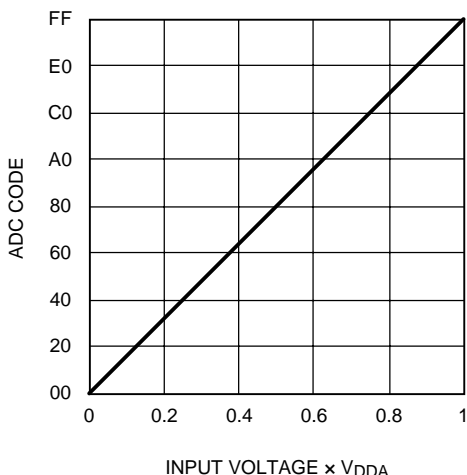

Figure 33. ADC Code vs Input Voltage in Temperature Measurement Mode

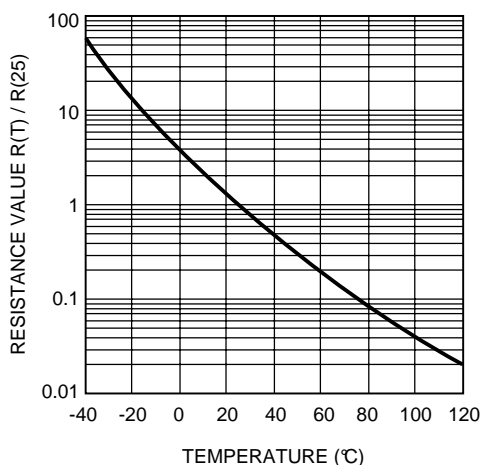

Figure 34. Example Curve for Thermistor

EXAMPLE TEMP SENSOR READING AT DIFFERENT TEMPERATURES (R(25°C)=1MΩ)

T°C	R(MΩ)	Rt(MΩ)	V(ASE)
-40	1	60	2.7540984
0	1	4	2.24
25	1	1	1.4
60	1	0.2	0.4666667
100	1	0.04	0.1076923

7V Shielding

To shield LP3954 from high input voltages 6...7.2V the use of external 2.8V LDO is required. This 2.8V voltage protects internally the device against high voltage condition. The recommended connection is as shown in the picture below. Internally both logic and analog circuitry works at 2.8V supply voltage. Both supply voltage pins should have separate filtering capacitors.

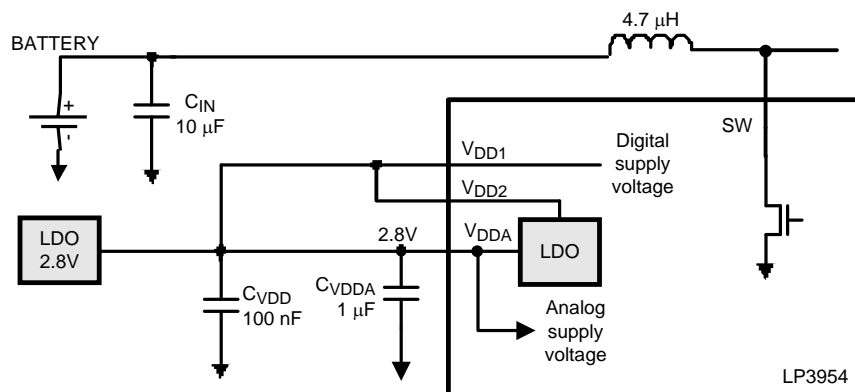

In cases where high voltage is not an issue the connection is as shown below.

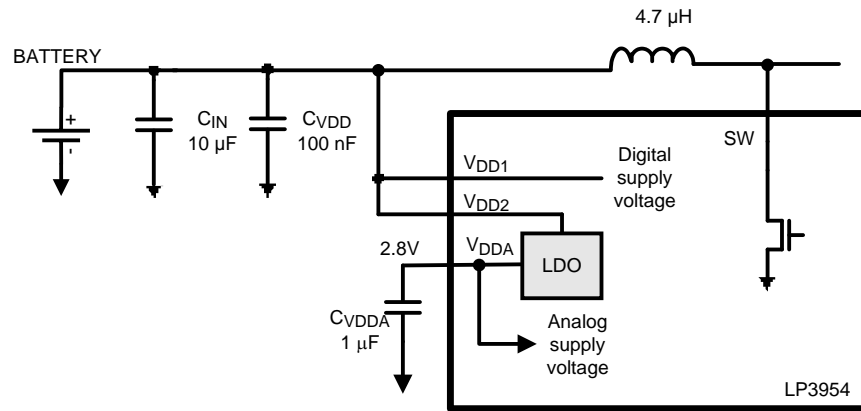

Logic Interface Characteristics

($1.65V \leq V_{DDIO} \leq V_{DD1,2}V$) (Unless otherwise noted)

Parameter	Test Conditions	Min	Typ	Max	Unit	
LOGIC INPUTS SS, SI, SCK/SCL, SYNC/PWM, IF_SEL, EN_FLASH						
V_{IL}	Input Low Level			$0.2 \times V_{DDIO}$	V	
V_{IH}	Input High Level	$0.8 \times V_{DDIO}$			V	
I_I	Logic Input Current	-1.0		1.0	µA	
f_{SCL}	Clock Frequency	I ² C Mode		400	kHz	
		SPI Mode, $V_{DDIO} > 1.8V$		13	MHz	
		SPI Mode, $1.65V \leq V_{DDIO} < 1.8V$		5	MHz	
LOGIC OUTPUT SO						
V_{OL}	Output Low Level	$I_{SO} = 3\text{ mA}$ $V_{DDIO} > 1.8V$		0.3	0.5	V
		$I_{SO} = 2\text{ mA}$ $1.65V \leq V_{DDIO} < 1.8V$		0.3		
V_{OH}	Output High Level	$I_{SO} = -3\text{ mA}$ $V_{DDIO} > 1.8V$	$V_{DDIO} - 0.5$	$V_{DDIO} - 0.3$		V
		$I_{SO} = -2\text{ mA}$ $1.65V \leq V_{DDIO} < 1.8V$	$V_{DDIO} - 0.5$	$V_{DDIO} - 0.3$		
I_L	Output Leakage Current	$V_{SO} = 2.8V$		1.0	µA	
LOGIC OUTPUT SDA						
V_{OL}	Output Low Level	$I_{SDA} = 3\text{ mA}$		0.3	0.5	V

Control Interface

The LP3954 supports two different interface modes:

- SPI interface (4 wire, serial)
- I²C compatible interface (2 wire, serial)

User can define the serial interface by IF_SEL pin. IF_SEL=0 selects the I²C mode.

SPI INTERFACE

LP3954 is compatible with SPI serial bus specification and it operates as a slave. The transmission consists of 16-bit Write and Read Cycles. One cycle consists of 7 Address bits, 1 Read/Write (RW) bit and 8 Data bits. RW bit high state defines a Write Cycle and low defines a Read Cycle. SO output is normally in high-impedance state and it is active only when Data is sent out during a Read Cycle. A pull-up resistor may be needed in SO line if a floating logic signal can cause unintended current consumption in the input circuits where SO is connected. The Address and Data are transmitted MSB first. The Slave Select signal SS must be low during the Cycle transmission. SS resets the interface when high and it has to be taken high between successive Cycles. Data is clocked in on the rising edge of the SCK clock signal, while data is clocked out on the falling edge of SCK.

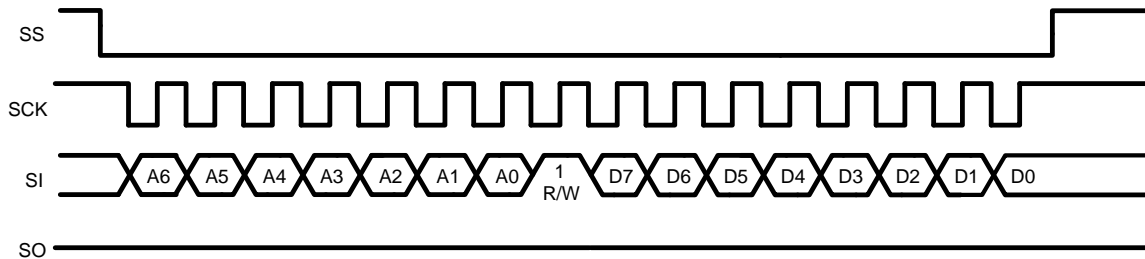

Figure 35. SPI Write Cycle

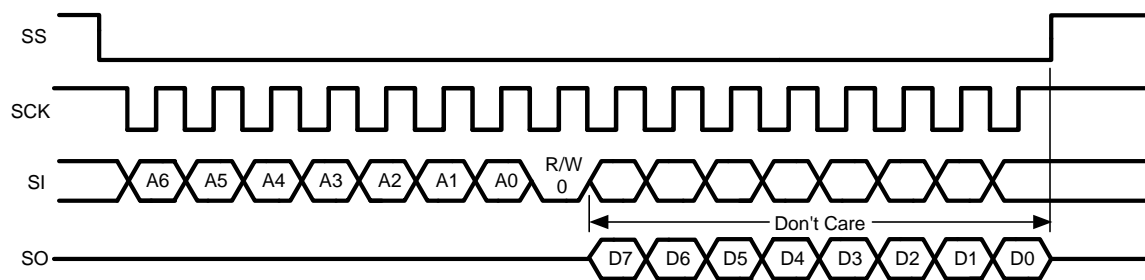

Figure 36. SPI Read Cycle

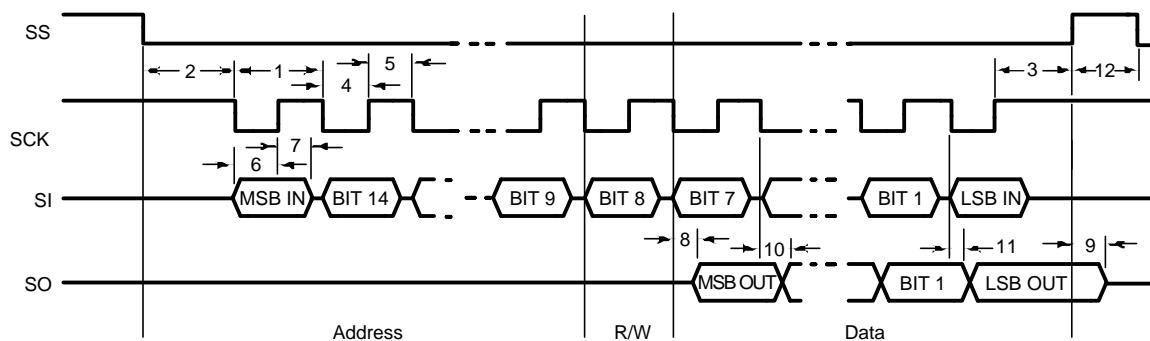

Figure 37. SPI Timing Diagram

SPI Timing Parameters

$$V_{DD} = V_{DD_IO} = 2.775V$$

Symbol	Parameter	Limit ⁽¹⁾		Unit
		Min	Max	
1	Cycle Time	70		ns
2	Enable Lead Time	35		ns

(1) **Note:** Data ensured by design.

Symbol	Parameter	Limit ⁽¹⁾		Unit
		Min	Max	
3	Enable Lag Time	35		ns
4	Clock Low Time	35		ns
5	Clock High Time	35		ns
6	Data Setup Time	20		ns
7	Data Hold Time	0		ns
8	Data Access Time		20	ns
9	Disable Time		10	ns
10	Data Valid		20	ns
11	Data Hold Time	0		ns

I²C COMPATIBLE INTERFACE

I²C Signals

In I²C mode the LP3954 pin SCK is used for the I²C clock SCL and the pin SS is used for the I²C data signal SDA. Both these signals need a pull-up resistor according to I²C specification. SI pin is the address select pin. I²C address for LP3954 is 54h when SI = 0 and 55h when SI = 1. Unused pin SO can be left unconnected.

I²C Data Validity

The data on SDA line must be stable during the HIGH period of the clock signal (SCL). In other words, state of the data line can only be changed when CLK is LOW.

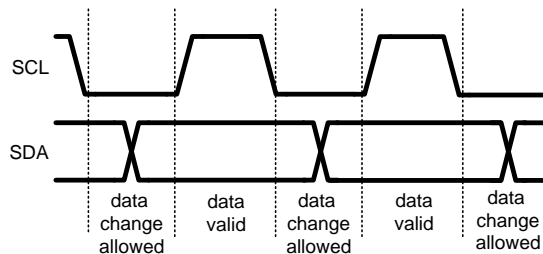
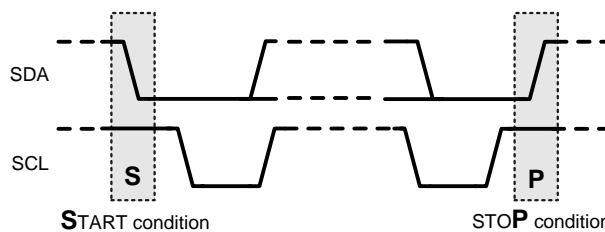

Figure 38. I²C Signals: Data Validity

I²C Start and Stop Conditions

START and STOP bits classify the beginning and the end of the I²C session. START condition is defined as SDA signal transitioning from HIGH to LOW while SCL line is HIGH. STOP condition is defined as the SDA transitioning from LOW to HIGH while SCL is HIGH. The I²C master always generates START and STOP bits. The I²C bus is considered to be busy after START condition and free after STOP condition. During data transmission, I²C master can generate repeated START conditions. First START and repeated START conditions are equivalent, function-wise.



Transferring Data

Every byte put on the SDA line must be eight bits long, with the most significant bit (MSB) being transferred first. Each byte of data has to be followed by an acknowledge bit. The acknowledge related clock pulse is generated by the master. The transmitter releases the SDA line (HIGH) during the acknowledge clock pulse. The receiver must pull down the SDA line during the 9th clock pulse, signifying an acknowledge. A receiver which has been addressed must generate an acknowledge after each byte has been received.

After the START condition, the I²C master sends a chip address. This address is seven bits long followed by an eighth bit which is a data direction bit (R/W). The LP3954 address is 54h or 55h as selected with SI pin. For the eighth bit, a “0” indicates a WRITE and a “1” indicates a READ. The second byte selects the register to which the data will be written. The third byte contains data to write to the selected register.

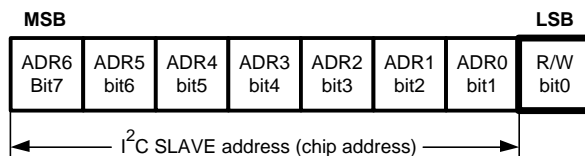
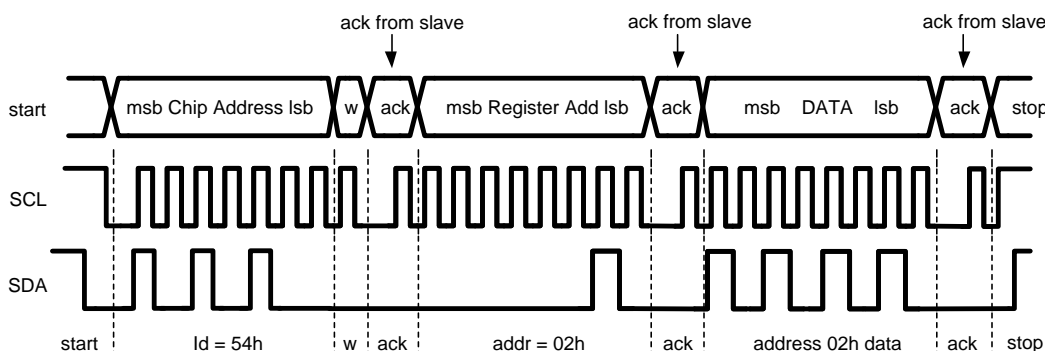

Figure 39. I²C Chip Address

Register changes take an effect at the SCL rising edge during the last ACK from slave.



w = write (SDA = “0”)
 r = read (SDA = “1”)
 ack = acknowledge (SDA pulled down by either master or slave)
 rs = repeated start
 id = 7-bit chip address, 54h (SI=0) or 55h (SI=1) for LP3954.

Figure 40. I²C Write Cycle

When a READ function is to be accomplished, a WRITE function must precede the READ function, as shown in the Read Cycle waveform.

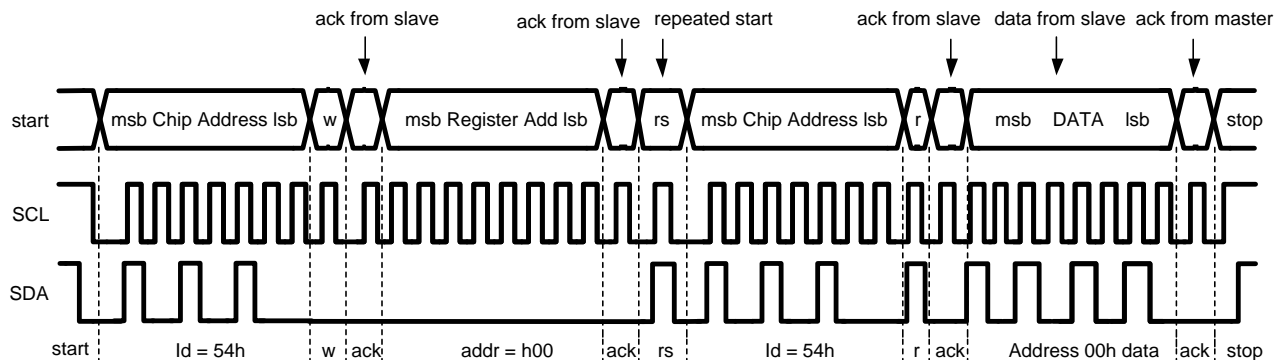
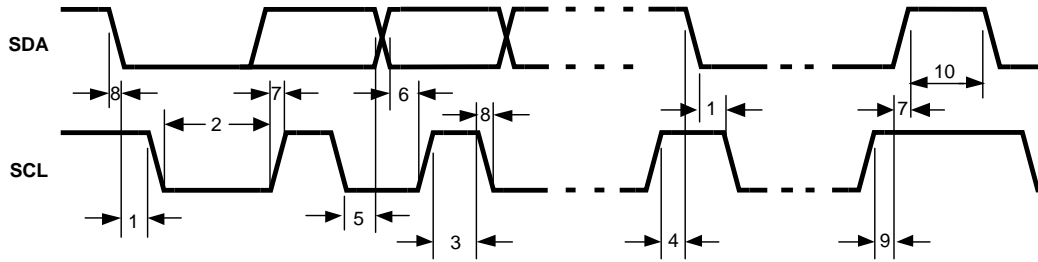

Figure 41. I²C Read Cycle

Figure 42. I²C Timing Diagram
I²C Timing Parameters ($V_{DD1,2} = 3.0$ to $4.5V$, $V_{DDIO} = 1.65V$ to $V_{DD1,2}$)

Symbol	Parameter	Limit ⁽¹⁾		Unit
		Min	Max	
1	Hold Time (repeated) START Condition	0.6		μs
2	Clock Low Time	1.3		μs
3	Clock High Time	600		ns
4	Setup Time for a Repeated START Condition	600		ns
5	Data Hold Time (Output direction, delay generated by LP3954)	300	900	ns
5	Data Hold Time (Input direction, delay generated by the Master)	0	900	ns
6	Data Setup Time	100		ns
7	Rise Time of SDA and SCL	20+0.1C _b	300	ns
8	Fall Time of SDA and SCL	15+0.1C _b	300	ns
9	Set-up Time for STOP condition	600		ns
10	Bus Free Time between a STOP and a START Condition	1.3		μs
C _b	Capacitive Load for Each Bus Line	10	200	pF

(1) **NOTE:** Data ensured by design

Autoincrement mode is available, with this possible read or write few byte with autoincreasing addresses, but LP3954 has holes in address register map, and is recommended to use autoincrement mode only for the pattern command registers.

Recommended External Components

OUTPUT CAPACITOR, C_{OUT}

The output capacitor C_{OUT} directly affects the magnitude of the output ripple voltage. In general, the higher the value of C_{OUT}, the lower the output ripple magnitude. Multilayer ceramic capacitors with low ESR are the best choice. At the lighter loads, the low ESR ceramics offer a much lower V_{out} ripple than the higher ESR tantalums of the same value. At the higher loads, the ceramics offer a slightly lower V_{out} ripple magnitude than the tantalums of the same value. However, the dv/dt of the V_{out} ripple with the ceramics is much lower than the tantalums under all load conditions. Capacitor voltage rating must be sufficient, 10V or greater is recommended.

Some ceramic capacitors, especially those in small packages, exhibit a strong capacitance reduction with the increased applied voltage. The capacitance value can fall to below half of the nominal capacitance. Too low output capacitance will increase the noise and it can make the boost converter unstable.

INPUT CAPACITOR, C_{IN}

The input capacitor C_{IN} directly affects the magnitude of the input ripple voltage and to a lesser degree the V_{OUT} ripple. A higher value C_{IN} will give a lower V_{IN} ripple. Capacitor voltage rating must be sufficient, 10V or greater is recommended.

OUTPUT DIODE, D_{OUT}

A Schottky diode should be used for the output diode. To maintain high efficiency the average current rating of the schottky diode should be larger than the peak inductor current (1A). Schottky diodes with a low forward drop and fast switching speeds are ideal for increasing efficiency in portable applications. Choose a reverse breakdown of the schottky diode larger than the output voltage. Do not use ordinary rectifier diodes, since slow switching speeds and long recovery times cause the efficiency and the load regulation to suffer.

INDUCTOR, L_1

The LP3954's high switching frequency enables the use of the small surface mount inductor. A 4.7 μH shielded inductor is suggested for 2 MHz operation, 10 μH should be used at 1 MHz. The inductor should have a saturation current rating higher than the peak current it will experience during circuit operation (**1A**). Less than 300 m Ω ESR is suggested for high efficiency. Open core inductors cause flux linkage with circuit components and interfere with the normal operation of the circuit. This should be avoided. For high efficiency, choose an inductor with a high frequency core material such as ferrite to reduce the core losses. To minimize radiated noise, use a toroid, pot core or shielded core inductor. The inductor should be connected to the SW pin as close to the IC as possible.

LIST OF RECOMMENDED EXTERNAL COMPONENTS

Symbol	Symbol Explanation	Value	Unit	Type
C_{VDD1}	C between VDD1 and GND	100	nF	Ceramic, X7R / X5R
C_{VDD2}	C between VDD2 and GND	100	nF	Ceramic, X7R / X5R
C_{VDDIO}	C between VDDIO and GND	100	nF	Ceramic, X7R / X5R
C_{VDDA}	C between VDDA and GND	1	μF	Ceramic, X7R / X5R
C_{OUT}	C between FB and GND	10	μF	Ceramic, X7R / X5R, 10V
C_{IN}	C between battery voltage and GND	10	μF	Ceramic, X7R / X5R
L_{BOOST}	L between SW and V_{BAT} at 2 MHz	4.7	μH	Shielded, low ESR, Isat 1A
C_{VREF}	C between V_{REF} and GND	100	nF	Ceramic, X7R
C_{VDDIO}	C between V_{DDIO} and GND	100	nF	Ceramic, X7R
R_{FLASH}	R between I_{FLASH} and GND	1.2	k Ω	$\pm 1\%$
R_{RGB}	R between I_{RGB} and GND	5.6	k Ω	$\pm 1\%$
R_{RT}	R between I_{RT} and GND	82	k Ω	$\pm 1\%$
D_{OUT}	Rectifying Diode (V_f at maxload)	0.3	V	Schottky diode
C_{CASE}	C between Audio input and ASE	100	nF	Ceramic, X7R / X5R
LEDs		User defined		
D_{LIGHT}	Light Sensor	TDK BSC2015		

Application Examples

EXAMPLE 1

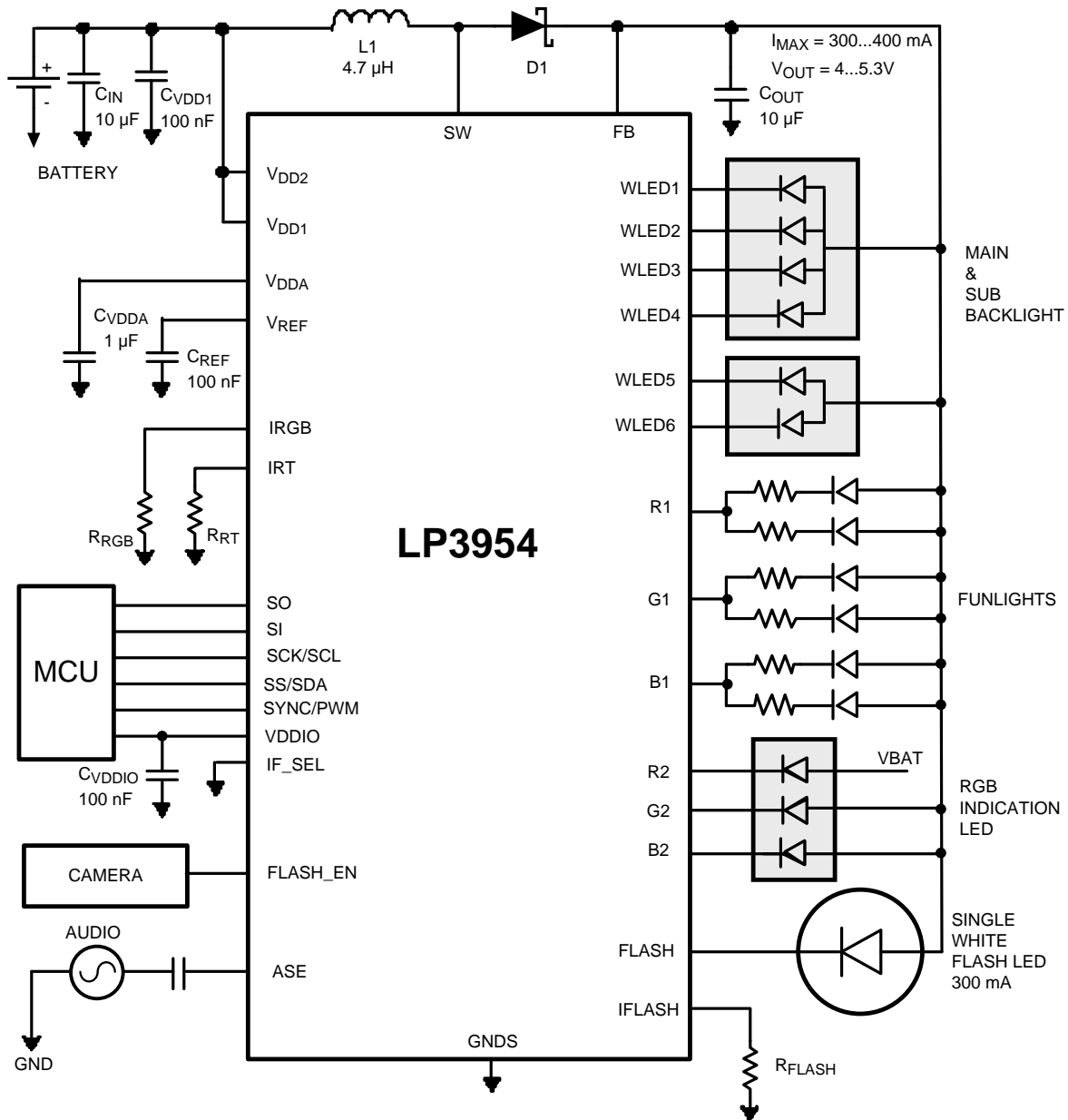

- MAIN BACKLIGHT
- SUB BACKLIGHT
- AUDIO SYNCHRONIZED FUNLIGHTS
- RGB INDICATION LIGHT
- FLASH LED

Figure 43. Flip Phone

EXAMPLE 2

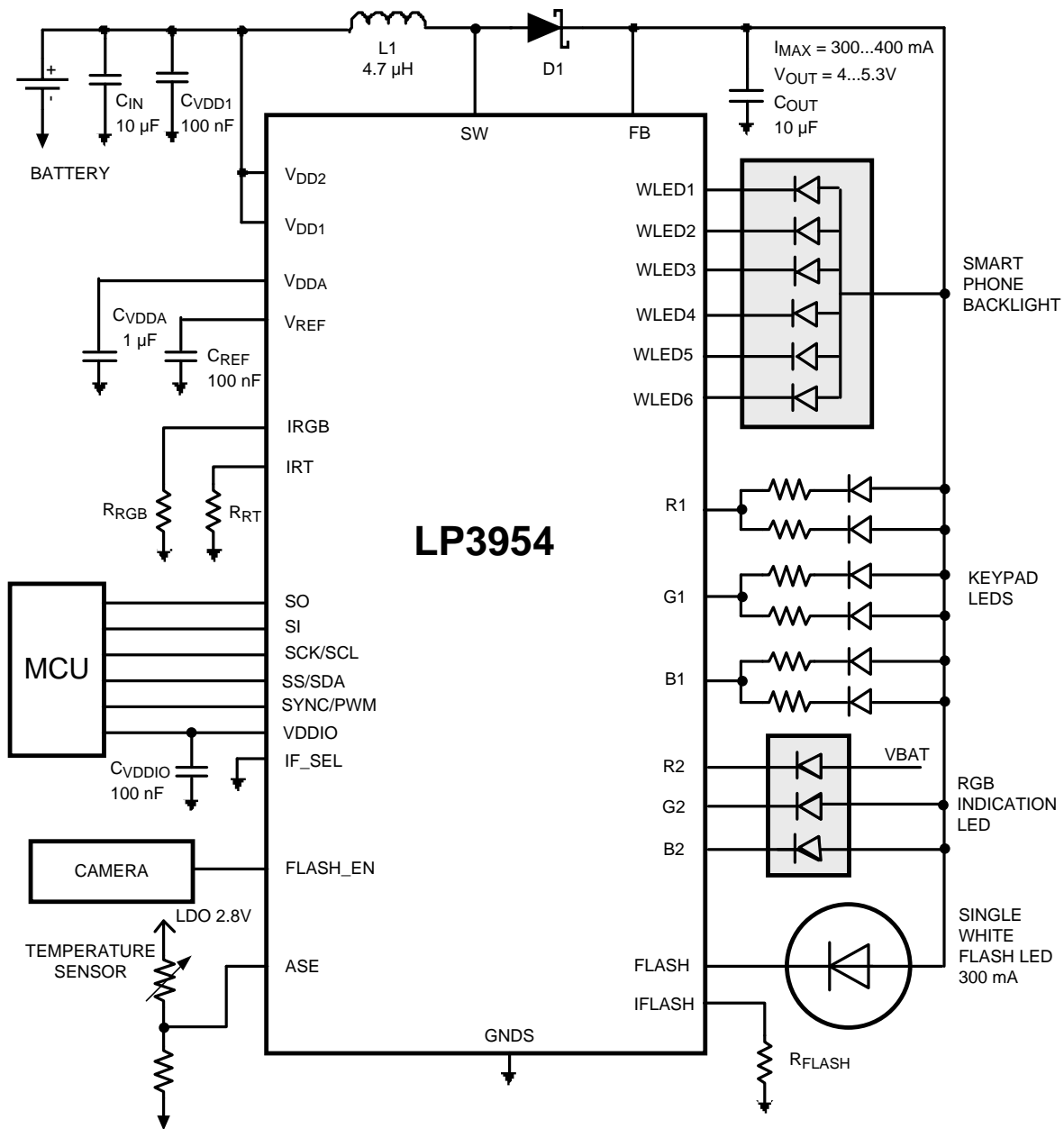

- 6 WHITE LED BACKLIGHT
- KEY PAD LIGHTS
- RGB INDICATION LED
- WHITE SINGLE LED FLASH
- TEMPERATURE SENSOR

Figure 44. Smart Phone

EXAMPLE 3

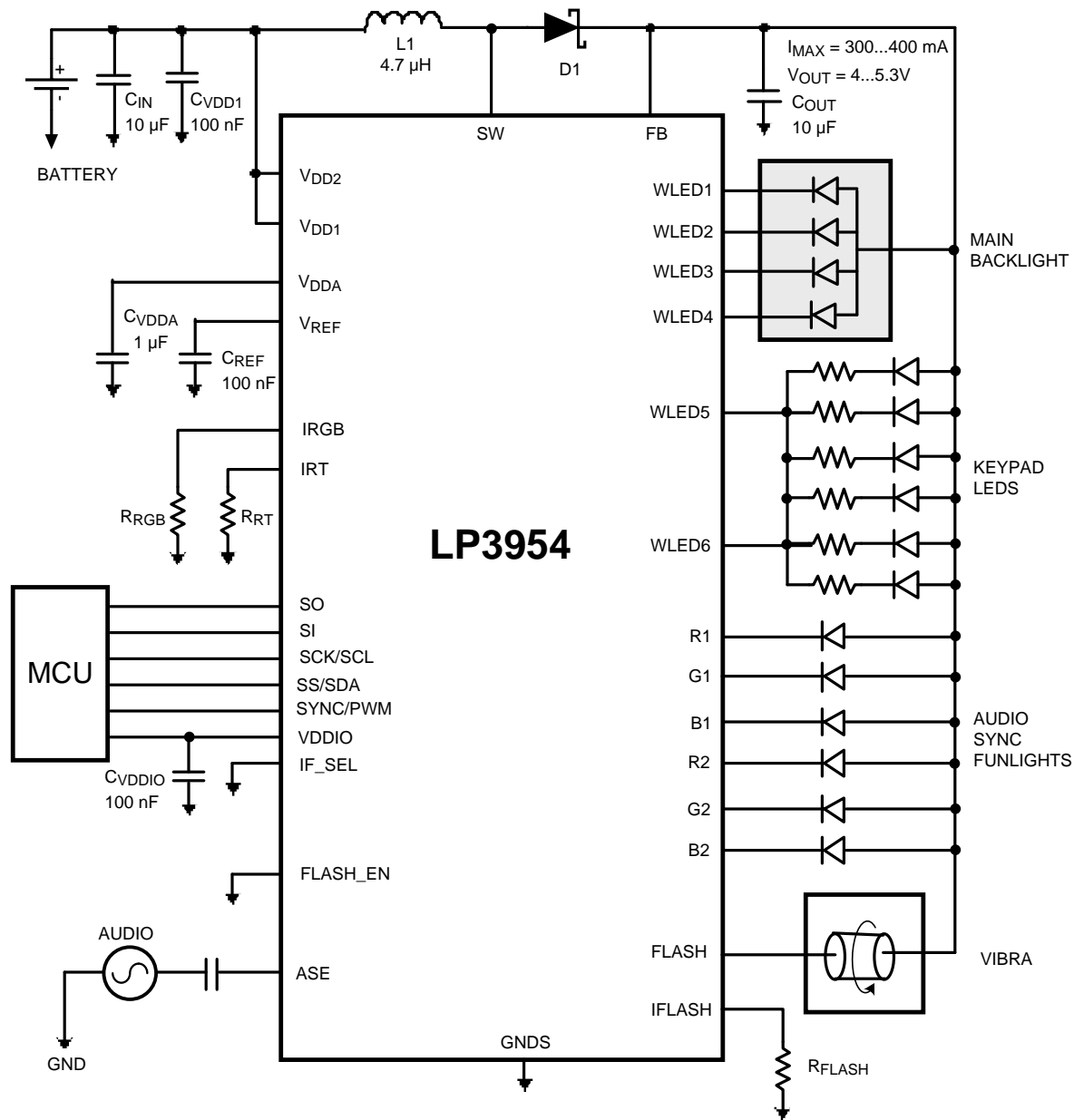

- MAIN BACKLIGHT
- KEYPAD LIGHTS
- AUDIO SYNCHRONIZED FUNLIGHTS
- VIBRA

Figure 45. Candybar Phone

EXAMPLE 4

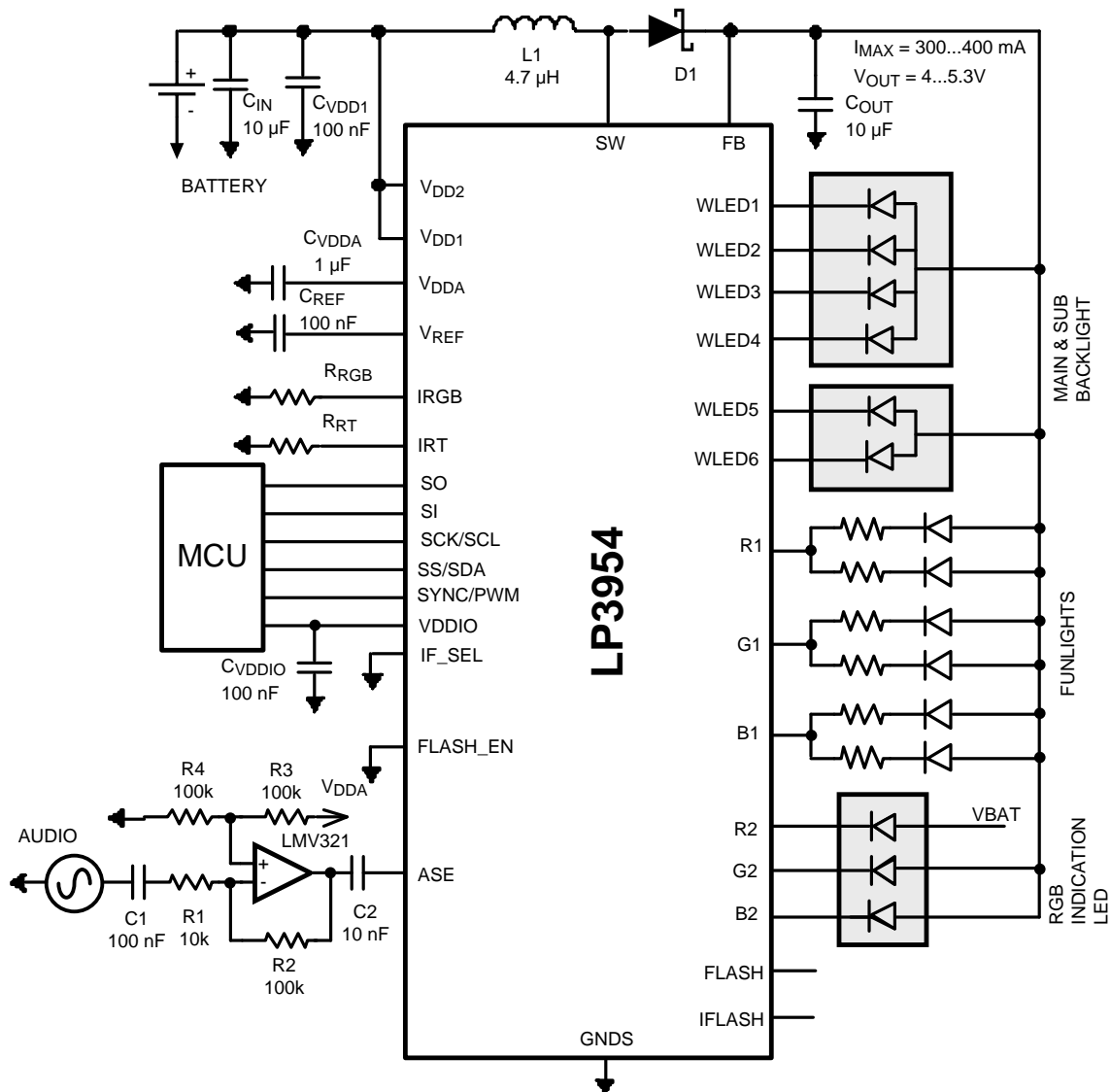

- MAIN BACKLIGHT
- SUB BACKLIGHT
- AUDIO SYNCHRONIZED FUNLIGHTS
- RGB INDICATION LIGHT

There may be cases where the audio input signal going into the LP3954 is too weak for audio synchronization. This figure presents a single-supply inverting amplifier connected to the ASE input for audio signal amplification. The amplification is +20 dB, which is well enough for 20 mVp-p audio signal. Because the amplifier (LMV321) is operating in single supply voltage, a voltage divider using R3 and R4 is implemented to bias the amplifier so the input signal is within the input common-mode voltage range of the amplifier. The capacitor C1 is placed between the inverting input and resistor R1 to block the DC signal going into the audio signal source. The values of R1 and C1 affect the cutoff frequency, $f_c = 1/(2\pi R1 C1)$, in this case it is around 160 Hz. As a result, the LMV321 output signal is centered around mid-supply, that is $V_{DDA}/2$. The output can swing to both rails, maximizing the signal-to-noise ratio in a low voltage system

Figure 46. Using Extra Amplifier

EXAMPLE 5

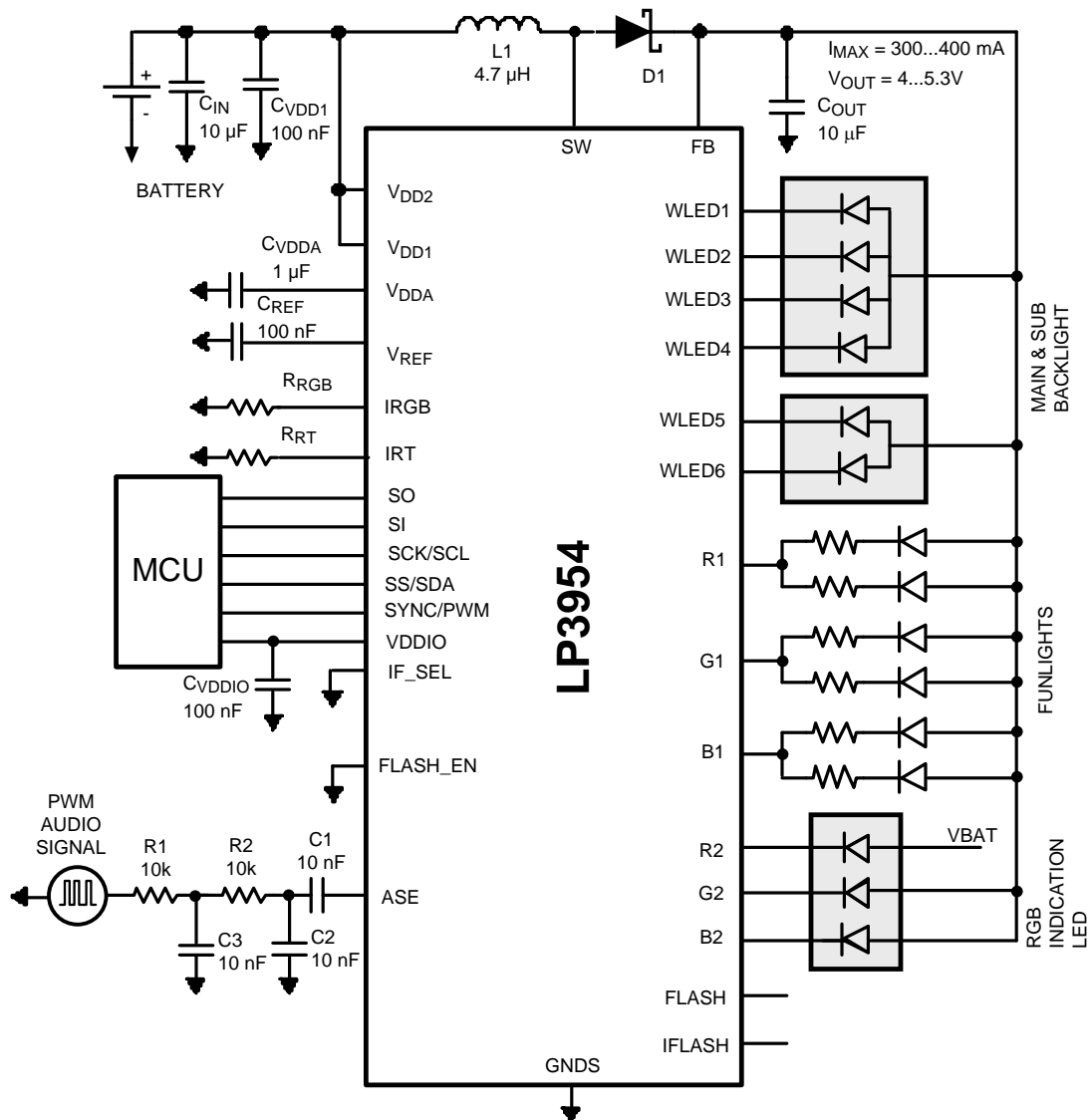

- MAIN BACKLIGHT
- SUB BACKLIGHT
- AUDIO SYNCHRONIZED FUNLIGHTS
- RGB INDICATION LIGHT

Here, a second order RC-filter is used on the ASE input to convert a PWM signal to an analog waveform.

Figure 47. Using PWM Signal

More application information is available in the document "LP3954 Evaluation Kit".

LP3954 Control Registers
Table 3. LP3954 Control Register Names and Default Values

ADDR (HEX)	REGISTER	D7	D6	D5	D4	D3	D2	D1	D0	
00	RGB Ctrl	cc_rgb1	cc_rgb2	r1sw	g1sw	b1sw	r2sw	g2sw	b2sw	
		1	1	0	0	0	0	0	0	
07	Ext. PWM control	wled1_4_pwm	wled5_6_pwm	r1_pwm	g1_pwm	b1_pwm	r2_pwm	g2_pwm	b2_pwm	
		0	0	0	0	0	0	0	0	
08	WLED control			slope	fade_sel	en_fade	displ	en_w1_4	en_w5_6	
				0	0	0	0	0	0	
09	WLED1-4	wled1_4[7:0]								
		0	0	0	0	0	0	0	0	
0A	WLED5-6	wled5_6[7:0]								
		0	0	0	0	0	0	0	0	
0B	Enables	pwm_sync	nstby	en_boost			en_autoload	rgb_sel[1:0]		
		0	0	0			1	0	0	
0C	ADC output	data[7:0]								
		0	0	0	0	0	0	0	0	
0D	Boost output	boost[7:0]								
		0	0	1	1	1	1	1	1	
0E	Boost_frq						freq_sel[2:0]			
							1	1	1	
10	HC_Flash			hc_pwm	fl_t[1:0]		hc[1:0]		en_hcflash	
				0	0	0	0	0	0	
11	Pattern gen ctrl						rgb_start	loop	log	
							0	0	0	
12	RGB1 max current			ir1[1:0]		ig1[1:0]		ib1[1:0]		
				0	0	0	0	0	0	
13	RGB2 max current			ir2[1:0]		ig2[1:0]		ib2[1:0]		
				0	0	0	0	0	0	
2A	audio sync CTRL1	gain_sel[2:0]			sync_mode	en_agc	en_sync	input_sel[1:0]		
		0	0	0	0	0	0	1	1	
2B	audio sync CTRL2				en_avg	mode_ctrl[1:0]		speed_ctrl[1:0]		
					0	0	0	0	0	
50	Command 1A	r[2:0]		g[2:0]			cet[3:2]			
		0	0	0	0	0	0	0	0	
51	Command 1B	cet[1:0]		b[2:0]			tt[2:0]			
		0	0	0	0	0	0	0	0	
52	Command 2A	r[2:0]		g[2:0]			cet[3:2]			
		0	0	0	0	0	0	0	0	
53	Command 2B	cet[1:0]		b[2:0]			tt[2:0]			
		0	0	0	0	0	0	0	0	
54	Command 3A	r[2:0]		g[2:0]			cet[3:2]			
		0	0	0	0	0	0	0	0	
55	Command 3B	cet[1:0]		b[2:0]			tt[2:0]			
		0	0	0	0	0	0	0	0	
56	Command 4A	r[2:0]		g[2:0]			cet[3:2]			
		0	0	0	0	0	0	0	0	
57	Command 4B	cet[1:0]		b[2:0]			tt[2:0]			
		0	0	0	0	0	0	0	0	

Table 3. LP3954 Control Register Names and Default Values (continued)

ADDR (HEX)	REGISTER	D7	D6	D5	D4	D3	D2	D1	D0
58	Command 5A	r[2:0]			g[2:0]			cet[3:2]	
		0	0	0	0	0	0	0	0
59	Command 5B	cet[1:0]		b[2:0]			tt[2:0]		
		0	0	0	0	0	0	0	0
5A	Command 6A	r[2:0]			g[2:0]			cet[3:2]	
		0	0	0	0	0	0	0	0
5B	Command 6B	cet[1:0]		b[2:0]			tt[2:0]		
		0	0	0	0	0	0	0	0
5C	Command 7A	r[2:0]			g[2:0]			cet[3:2]	
		0	0	0	0	0	0	0	0
5D	Command 7B	cet[1:0]		b[2:0]			tt[2:0]		
		0	0	0	0	0	0	0	0
5E	Command 8A	r[2:0]			g[2:0]			cet[3:2]	
		0	0	0	0	0	0	0	0
5F	Command 8B	cet[1:0]		b[2:0]			tt[2:0]		
		0	0	0	0	0	0	0	0
60	Reset	Writing any data to Reset Register resets LP3954							

LP3954 Registers

REGISTER BIT EXPLANATIONS

Each register is shown with a key indicating the accessibility of the each individual bit, and the initial condition:

Register Bit Accessibility and Initial Condition	
Key	Bit Accessibility
rw	Read/write
r	Read only
-0,-1	Condition after POR

RGB CTRL (00H) – RGB LEDS CONTROL REGISTER

D7	D6	D5	D4	D3	D2	D1	D0
cc_rgb1	cc_rgb2	r1sw	g1sw	b1sw	r2sw	g2sw	b2sw
rw-1	rw-1	rw-0	rw-0	rw-0	rw-0	rw-0	rw-0

cc_rgb1	Bit 7	0 - R1, G1 and B1 are constant current sinks, current limited internally 1 - R1, G1 and B1 are switches, limit current with external ballast resistor
cc_rgb2	Bit 6	0 - R2, G2 and B2 are constant current sinks, current limited internally 1 - R2, G2 and B2 are switches, limit current with external ballast resistor
r1sw	Bit 5	0 - R1 disabled 1 - R1 enabled
g1sw	Bit 4	0 - G1 disabled 1 - G1 enabled
b1sw	Bit 3	0 - B1 disabled 1 - B1 enabled
r2sw	Bit 2	0 - R2 disabled 1 - R2 enabled
g2sw	Bit 1	0 - G2 disabled 1 - G2 enabled
b2sw	Bit 0	0 - B2 disabled 1 - B2 enabled

EXT_PWM_CONTROL (07H) – EXTERNAL PWM CONTROL REGISTER

D7	D6	D5	D4	D3	D2	D1	D0
wled1_4_pwm	wled5_6_pwm	r1_pwm	g1_pwm	b1_pwm	r2_pwm	g2_pwm	b2_pwm
rw-0	rw-0	rw-0	rw-0	rw-0	rw-0	rw-0	rw-0

wled1_4_pwm	Bit 7	0 – WLED1...WLED4 PWM control disabled 1 – WLED1...WLED4 PWM control enabled
wled5_6_pwm	Bit 6	0 – WLED5, WLED6 PWM control disabled 1 – WLED5, WLED6 PWM control enabled
r1_pwm	Bit 5	0 – R1 PWM control disabled 1 – R1 PWM control enabled
g1_pwm	Bit 4	0 – G1 PWM control disabled 1 – G1 PWM control enabled
b1_pwm	Bit 3	0 – RB PWM control disabled 1 – B1 PWM control enabled
r2_pwm	Bit 2	0 – R2 PWM control disabled 1 – R2 PWM control enabled
g2_pwm	Bit 1	0 – G2 PWM control disabled 1 – G2 PWM control enabled
b2_pwm	Bit 0	0 – B2 PWM control disabled 1 – B2 PWM control enabled

WLED CONTROL (08H) – WLED CONTROL REGISTER

D7	D6	D5	D4	D3	D2	D1	D0
		slope	fade_sel	en_fade	displ	en_w1_4	en_w5_6
r-0	r-0	rw-0	rw-0	rw-0	rw-0	rw-0	rw-0

slope	Bit 5	0 – fade execution time 1.3 sec 1 – fade execution time 0.65 sec
fade_sel	Bit 4	0 – fade control for WLED1... WLED4 1 – fade control for WLED5, WLED6
en_fade	Bit 3	0 – automatic fade disabled 1 – automatic fade enabled
displ	Bit 2	0 – WLED1-4 and WLED5-6 are controlled separately 1 – WLED1-4 and WLED5-6 are controlled with WLED1-4 controls
en_w1_4	Bit 1	0 – WLED1...WLED4 disabled 1 – WLED1...WLED4 enabled
en_w5_6	Bit 0	0 – WLED5,WLED6 disabled 1 – WLED5,WLED6 enabled

WLED1-4 (09H) – WLED1...WLED4 BRIGHTNESS CONTROL REGISTER

D7	D6	D5	D4	D3	D2	D1	D0
wled1_4[7:0]							
rw-0	rw-0	rw-0	rw-0	rw-0	rw-0	rw-0	rw-0

wled1_4[7:0]	Bits 7-0	Adjustment	
		wled1_4[7:0]	Typical driver current (ma)
		0000 0000	0
		0000 0001	0.1
		0000 0010	0.2
		0000 0011	0.3
		0000 0100	0.4
	
		1111 1101	25.3
		1111 1110	25.4
		1111 1111	25.5

WLED5-6 (0AH) – WLED5, WLED6 BRIGHTNESS CONTROL REGISTER

D7	D6	D5	D4	D3	D2	D1	D0
wled5_5[7:0]							
rw-0	rw-0	rw-0	rw-0	rw-0	rw-0	rw-0	rw-0

wled5_6[7:0]	Bits 7-0	Adjustment	
		wled5_6[7:0]	Typical driver current (ma)
		0000 0000	0
		0000 0001	0.1
		0000 0010	0.2
		0000 0011	0.3
		0000 0100	0.4
	
		1111 1101	25.3
		1111 1110	25.4
		1111 1111	25.5

ENABLES (0BH) – ENABLES REGISTER

D7	D6	D5	D4	D3	D2	D1	D0
pwm_sync	nstby	en_boost			en_autoload	rgb_sel[1:0]	
rw-0	rw-0	rw-0	r-0	r-0	rw-1	rw-0	rw-0

pwm_sync	Bit 7	0 – synchronization to external clock disabled 1 – synchronization to external clock enabled		
nstby	Bit 6	0 – LP3954 standby mode 1 – LP3954 active mode		
en_boost	Bit 5	0 – boost converter disabled 1 – boost converter enabled		
en_autoload	Bit 2	0 – internal boost converter active load off 1 – internal boost converter active load on		
rgb_sel[1:0]	Bits 1-0	Color LED control mode selection		
		rgb_sel[1:0]	Audio sync connected to	Pattern generator connected to
		00	none	RGB1 & RGB2
		01	RGB1	RGB2
		10	RGB2	RGB1
		11	RGB1 & RGB2	none

ADC_OUTPUT (0CH) – ADC DATA REGISTER

D7	D6	D5	D4	D3	D2	D1	D0
data[7:0]							
r-0	r-0	r-0	r-0	r-0	r-0	r-0	r-0

data[7:0]	Bits 7-0	Data register ADC (Audio input, light or temperature sensors)
------------------	----------	---

BOOST_OUTPUT (0DH) – BOOST OUTPUT VOLTAGE CONTROL REGISTER

D7	D6	D5	D4	D3	D2	D1	D0
Boost[7:0]							
rw-0	rw-0	rw-1	rw-1	rw-1	rw-1	rw-1	rw-1

Boost[7:0]	Bits 7-0	Adjustment	
		Boost[7:0]	Typical boost output (V)
		0000 0000	4.00
		0000 0001	4.25
		0000 0011	4.40
		0000 0111	4.55
		0000 1111	4.70
		0001 1111	4.85
		0011 1111	5.00 (default)
		0111 1111	5.15
		1111 1111	5.30

BOOST_FRQ (0EH) – BOOST FREQUENCY CONTROL REGISTER

D7	D6	D5	D4	D3	D2	D1	D0
					freq_sel[2:0]		
r-0	r-0	r-0	r-0	r-0	rw-1	rw-1	rw-1

freq_sel[2:0]	Bits 7-0	Adjustment	
		freq_sel[2:0]	Frequency
		1xx	2.00 MHz
		01x	1.67 MHz
		00x	1.00 MHz

HC_FLASH (10H) – HIGH CURRENT FLASH DRIVER CONTROL REGISTER

D7	D6	D5	D4	D3	D2	D1	D0
		hc_pwm	fl_t[1:0]		hc[1:0]		en_hcflash
r-0	r-0	rw-0	rw-0	rw-0	rw-0	rw-0	rw-0

hc_pwm	Bit 5	0 – PWM for high current flash driver disabled 1 – PWM for high current flash driver enabled	
fl_t[1:0]	Bits 4-3	Flash duration for high current driver	
		fl_t[1:0]	Typical flash duration
		00	200 ms
		01	400 ms
		10	600 ms
		11	According EN_FLASH pin on duration

		Current control for high current flash driver	
hc[1:0]	Bits 2-1	hc[1:0]	current
		00	$0.25 \times I_{MAX(FLASH)}$
		01	$0.50 \times I_{MAX(FLASH)}$
		10	$0.75 \times I_{MAX(FLASH)}$
		11	$1.00 \times I_{MAX(FLASH)}$
en_hcflash	Bit 0	0 – high current flash driver disabled 1 – high current flash driver enabled	

PATTERN_GEN_CTRL (11H) – PATTERN GENERATOR CONTROL REGISTER

D7	D6	D5	D4	D3	D2	D1	D0
					rgb_start	loop	log
r-0	r-0	r-0	r-0	r-0	rw-0	rw-0	rw-0

rgb_start	Bit 2	0 – Pattern generator disabled 1 – execution pattern starting from command 1
loop	Bit 1	0 – pattern generator loop disabled (single patter) 1 – pattern generator loop enabled (execute until stopped)
log	Bit 0	0 – color intensity mode 0 1 – color intensity mode 1

RGB1_MAX_CURRENT (12H) – RGB1 DRIVER INDIVIDUAL MAXIMUM CURRENT CONTROL REGISTER

D7	D6	D5	D4	D3	D2	D1	D0
		ir1[1:0]		ig1[1:0]		ib1[1:0]	
r-0	r-0	rw-0	rw-0	rw-0	rw-0	rw-0	rw-0

		Maximum current for R1 driver	
ir1[1:0]	Bits 5-4	ir1[2:0]	Maximum output current
		00	$0.25 \times I_{MAX}$
		01	$0.50 \times I_{MAX}$
		10	$0.75 \times I_{MAX}$
		11	$1.00 \times I_{MAX}$
		Maximum current for G1 driver	
ig1[1:0]	Bits 3-2	ig2[1:0]	Maximum output current
		00	$0.25 \times I_{MAX}$
		01	$0.50 \times I_{MAX}$
		10	$0.75 \times I_{MAX}$
		11	$1.00 \times I_{MAX}$
		Maximum current for B1 driver	
ib1[1:0]	Bits 1-0	ib1[1:0]	Maximum output current
		00	$0.25 \times I_{MAX}$
		01	$0.50 \times I_{MAX}$
		10	$0.75 \times I_{MAX}$
		11	$1.00 \times I_{MAX}$

RGB2_MAX_CURRENT (13H) – RGB2 DRIVER INDIVIDUAL MAXIMUM CURRENT CONTROL REGISTER

D7	D6	D5	D4	D3	D2	D1	D0
		ir2[1:0]		ig2[1:0]		ib2[1:0]	
rw-0	rw-0	rw-0	rw-0	rw-0	rw-0	rw-0	rw-0

ir2[1:0]	Bits 5-4	Maximum current for R2 driver	
		ir2[2:0]	Maximum output current
		00	0.25×I _{MAX}
		01	0.50×I _{MAX}
		10	0.75×I _{MAX}
11	1.00×I _{MAX}		

ig2[1:0]	Bits 3-2	Maximum current for G2 driver	
		ig2[1:0]	Maximum output current
		00	0.25×I _{MAX}
		01	0.50×I _{MAX}
		10	0.75×I _{MAX}
11	1.00×I _{MAX}		

ib2[1:0]	Bits 1-0	Maximum current for B2 driver	
		ib2[1:0]	Maximum output current
		00	0.25×I _{MAX}
		01	0.50×I _{MAX}
		10	0.75×I _{MAX}
11	1.00×I _{MAX}		

AUDIO_SYNC_CTRL1 (2AH) – AUDIO SYNCHRONIZATION AND ADC CONTROL REGISTER 1

D7	D6	D5	D4	D3	D2	D1	D0
gain_sel[2:0]			sync_mode	en_agc	en_sync	input_sel[1:0]	
rw-0	rw-0	rw-0	rw-0	rw-0	rw-0	rw-1	rw-1

gain_sel[2:0]	Bits 7-5	Input signal gain control	
		gain_sel[2:0]	gain, db
		000	0 (default)
		001	3
		010	6
		011	9
		100	12
		101	15
110	18		
111	21		

sync_mode	Bit 4	Input filter mode control 0 – Amplitude mode 1 – Frequency mode
en_agc	Bit 3	0 – automatic gain control disabled 1 – automatic gain control enabled
en_sync	Bit 2	0 – audio synchronization disabled 1 – audio synchronization enabled

input_sel[1:0]	Bits 1-0	ADC input selector	
		input_sel[1:0]	Input
		00	Single ended input signal (ASE)
		01	Temperature measurement
		10	Ambient light measurement
11	No input (default)		

AUDIO_SYNC_CTRL2 (2BH) – AUDIO SYNCHRONIZATION AND ADC CONTROL REGISTER 2

D7	D6	D5	D4	D3	D2	D1	D0
			en_avg	mode_ctrl[1:0]		speed_ctrl[1:0]	
r-0	r-0	r-0	rw-0	rw-0	rw-0	rw-0	rw-0

en_avg	Bit 4	0 – averaging disabled 1 – averaging enabled	
mode_ctrl[1:0]	Bits 3-2	Filtering mode control	
speed_ctrl[1:0]	Bits 1-0	LEDs light response time to audio input	
		speed_ctrl[1:0]	Response
		00	FASTEST (default)
		01	FAST
		10	MEDIUM
		11	SLOW

PATTERN CONTROL REGISTERS

Command_[1:8]A – Pattern Control Register A							
D7	D6	D5	D4	D3	D2	D1	D0
r[2:0]		g[2:0]			cet[3:2]		
rw-0	rw-0	rw-0	rw-0	rw-0	rw-0	rw-0	rw-0

Command_[1:8]B – Pattern Control Register B							
D7	D6	D5	D4	D3	D2	D1	D0
cet[1:0]		b[2:0]			tt[2:0]		
rw-0	rw-0	rw-0	rw-0	rw-0	rw-0	rw-0	rw-0

r[2:0]	Bits 7-5A	Red color intensity		
		r[2:0]	current, %	
			log=0	log=1
		000	0×I _{MAX}	0×I _{MAX}
		001	7%×I _{MAX}	1%×I _{MAX}
		010	14%×I _{MAX}	2%×I _{MAX}
		011	21%×I _{MAX}	4%×I _{MAX}
		100	32%×I _{MAX}	10%×I _{MAX}
		101	46%×I _{MAX}	21%×I _{MAX}
		110	71%×I _{MAX}	46%×I _{MAX}
	111	100%×I _{MAX}	100%×I _{MAX}	
* log bit is in pattern_gen_ctrl register				

g[2:0]	Bits 4-2A	Green color intensity		
		g[2:0]	current, %	
			log=0	log=1
		000	0×I _{MAX}	0×I _{MAX}
001	7%×I _{MAX}	1%×I _{MAX}		
010	14%×I _{MAX}	2%×I _{MAX}		
011	21%×I _{MAX}	4%×I _{MAX}		
100	32%×I _{MAX}	10%×I _{MAX}		
101	46%×I _{MAX}	21%×I _{MAX}		
110	71%×I _{MAX}	46%×I _{MAX}		
111	100%×I _{MAX}	100%×I _{MAX}		
* log bit is in pattern_gen_ctrl register				
cet[3:0]	Bits 1-0A 7-6B	Command execution time		
		cet[3:0]	CET duration, ms	
		0000	197	
		0001	393	
		0010	590	
		0011	786	
		0100	983	
		0101	1180	
		0110	1376	
		0111	1573	
		1000	1769	
		1001	1966	
		1010	2163	
		1011	2359	
		1100	2556	
		1101	2753	
1110	2949			
1111	3146			
b[2:0]	Bits 5-3B	Blue color intensity		
		b[2:0]	current, %	
			log=0	log=1
		000	0×I _{MAX}	0×I _{MAX}
		001	7%×I _{MAX}	1%×I _{MAX}
		010	14%×I _{MAX}	2%×I _{MAX}
		011	21%×I _{MAX}	4%×I _{MAX}
		100	32%×I _{MAX}	10%×I _{MAX}
		101	46%×I _{MAX}	21%×I _{MAX}
		110	71%×I _{MAX}	46%×I _{MAX}
111	100%×I _{MAX}	100%×I _{MAX}		
* log bit is in pattern_gen_ctrl register				

tt[2:0]	Bits 2-0B	Transition time	
		tt[2:0]	Transition time, ms
		000	0
		001	55
		010	110
		011	221
		100	442
		101	885
		110	1770
		111	3539

RESET (60H) - RESET REGISTER

D7	D6	D5	D4	D3	D2	D1	D0
Writing any data to Reset Register in address 60H can reset LP3954							
r-0	r-0	r-0	r-0	r-0	r-0	r-0	r-0

REVISION HISTORY

Changes from Revision C (March 2013) to Revision D	Page
<hr/> <ul style="list-style-type: none">• Changed layout of National Data Sheet to TI format	<hr/> 52

PACKAGING INFORMATION

Orderable Device	Status (1)	Package Type	Package Drawing	Pins	Package Qty	Eco Plan (2)	Lead/Ball Finish (6)	MSL Peak Temp (3)	Op Temp (°C)	Device Marking (4/5)	Samples
LP3954RL/NOPB	ACTIVE	DSBGA	YPG	36	250	Green (RoHS & no Sb/Br)	SNAG	Level-1-260C-UNLIM		D63B	Samples
LP3954TL/NOPB	ACTIVE	DSBGA	YZR	36	250	Green (RoHS & no Sb/Br)	SNAGCU	Level-1-260C-UNLIM	-30 to 85	D49B	Samples
LP3954TLX/NOPB	ACTIVE	DSBGA	YZR	36	1000	Green (RoHS & no Sb/Br)	SNAGCU	Level-1-260C-UNLIM	-30 to 85	D49B	Samples

(1) The marketing status values are defined as follows:

ACTIVE: Product device recommended for new designs.

LIFEBUY: TI has announced that the device will be discontinued, and a lifetime-buy period is in effect.

NRND: Not recommended for new designs. Device is in production to support existing customers, but TI does not recommend using this part in a new design.

PREVIEW: Device has been announced but is not in production. Samples may or may not be available.

OBsolete: TI has discontinued the production of the device.

(2) Eco Plan - The planned eco-friendly classification: Pb-Free (RoHS), Pb-Free (RoHS Exempt), or Green (RoHS & no Sb/Br) - please check <http://www.ti.com/productcontent> for the latest availability information and additional product content details.

TBD: The Pb-Free/Green conversion plan has not been defined.

Pb-Free (RoHS): TI's terms "Lead-Free" or "Pb-Free" mean semiconductor products that are compatible with the current RoHS requirements for all 6 substances, including the requirement that lead not exceed 0.1% by weight in homogeneous materials. Where designed to be soldered at high temperatures, TI Pb-Free products are suitable for use in specified lead-free processes.

Pb-Free (RoHS Exempt): This component has a RoHS exemption for either 1) lead-based flip-chip solder bumps used between the die and package, or 2) lead-based die adhesive used between the die and leadframe. The component is otherwise considered Pb-Free (RoHS compatible) as defined above.

Green (RoHS & no Sb/Br): TI defines "Green" to mean Pb-Free (RoHS compatible), and free of Bromine (Br) and Antimony (Sb) based flame retardants (Br or Sb do not exceed 0.1% by weight in homogeneous material)

(3) MSL, Peak Temp. - The Moisture Sensitivity Level rating according to the JEDEC industry standard classifications, and peak solder temperature.

(4) There may be additional marking, which relates to the logo, the lot trace code information, or the environmental category on the device.

(5) Multiple Device Markings will be inside parentheses. Only one Device Marking contained in parentheses and separated by a "~" will appear on a device. If a line is indented then it is a continuation of the previous line and the two combined represent the entire Device Marking for that device.

(6) Lead/Ball Finish - Orderable Devices may have multiple material finish options. Finish options are separated by a vertical ruled line. Lead/Ball Finish values may wrap to two lines if the finish value exceeds the maximum column width.

Important Information and Disclaimer: The information provided on this page represents TI's knowledge and belief as of the date that it is provided. TI bases its knowledge and belief on information provided by third parties, and makes no representation or warranty as to the accuracy of such information. Efforts are underway to better integrate information from third parties. TI has taken and

continues to take reasonable steps to provide representative and accurate information but may not have conducted destructive testing or chemical analysis on incoming materials and chemicals. TI and TI suppliers consider certain information to be proprietary, and thus CAS numbers and other limited information may not be available for release.

In no event shall TI's liability arising out of such information exceed the total purchase price of the TI part(s) at issue in this document sold by TI to Customer on an annual basis.

TAPE AND REEL INFORMATION

QUADRANT ASSIGNMENTS FOR PIN 1 ORIENTATION IN TAPE

*All dimensions are nominal

Device	Package Type	Package Drawing	Pins	SPQ	Reel Diameter (mm)	Reel Width W1 (mm)	A0 (mm)	B0 (mm)	K0 (mm)	P1 (mm)	W (mm)	Pin1 Quadrant
LP3954RL/NOPB	DSBGA	YPG	36	250	178.0	12.4	3.21	3.21	0.76	8.0	12.0	Q1
LP3954TL/NOPB	DSBGA	YZR	36	250	178.0	12.4	3.21	3.21	0.76	8.0	12.0	Q1
LP3954TLX/NOPB	DSBGA	YZR	36	1000	178.0	12.4	3.21	3.21	0.76	8.0	12.0	Q1

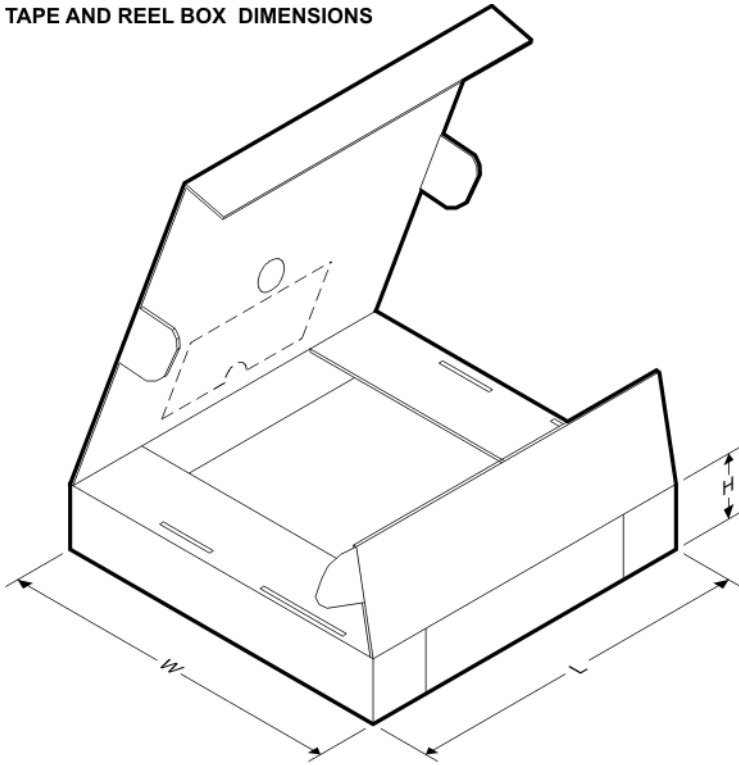
TAPE AND REEL BOX DIMENSIONS

*All dimensions are nominal

Device	Package Type	Package Drawing	Pins	SPQ	Length (mm)	Width (mm)	Height (mm)
LP3954RL/NOPB	DSBGA	YPG	36	250	210.0	185.0	35.0
LP3954TL/NOPB	DSBGA	YZR	36	250	210.0	185.0	35.0
LP3954TLX/NOPB	DSBGA	YZR	36	1000	210.0	185.0	35.0

YPG0036

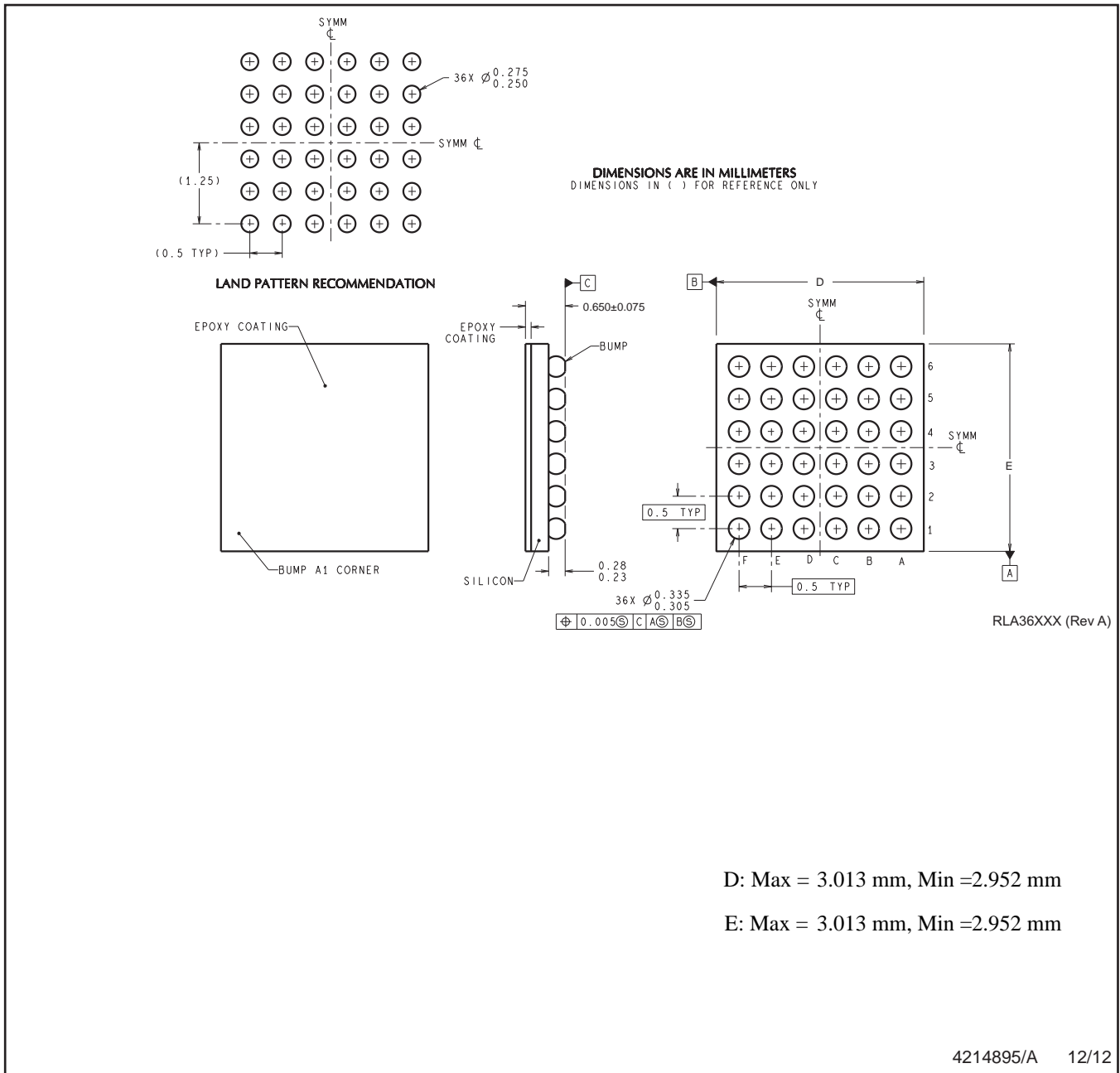

D: Max = 3.013 mm, Min = 2.952 mm

E: Max = 3.013 mm, Min = 2.952 mm

4214895/A 12/12

NOTES: A. All linear dimensions are in millimeters. Dimensioning and tolerancing per ASME Y14.5M-1994.
 B. This drawing is subject to change without notice.

YZR0036

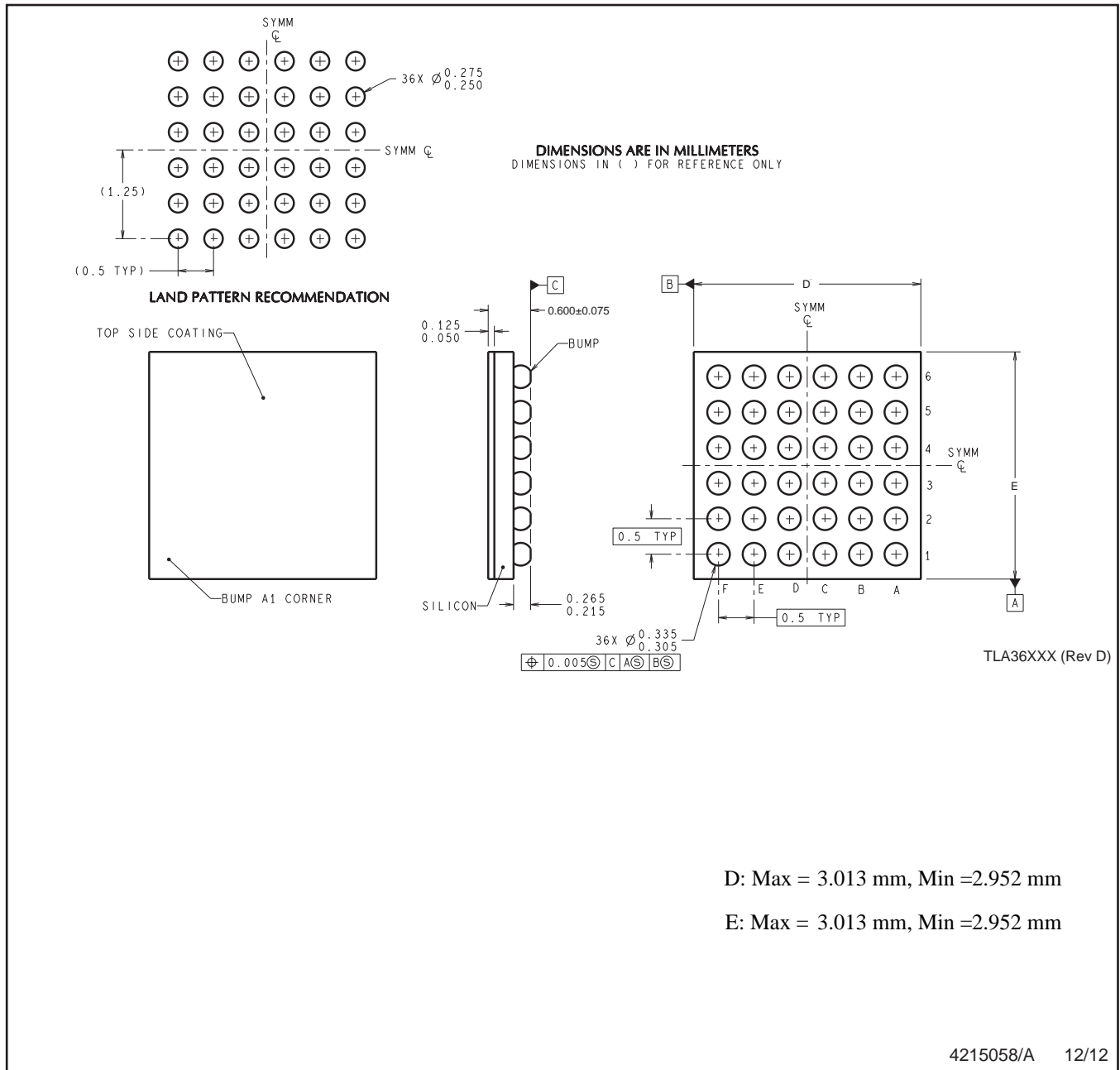

4215058/A 12/12

NOTES: A. All linear dimensions are in millimeters. Dimensioning and tolerancing per ASME Y14.5M-1994.
B. This drawing is subject to change without notice.

IMPORTANT NOTICE

Texas Instruments Incorporated (TI) reserves the right to make corrections, enhancements, improvements and other changes to its semiconductor products and services per JESD46, latest issue, and to discontinue any product or service per JESD48, latest issue. Buyers should obtain the latest relevant information before placing orders and should verify that such information is current and complete.

TI's published terms of sale for semiconductor products (<http://www.ti.com/sc/docs/stdterms.htm>) apply to the sale of packaged integrated circuit products that TI has qualified and released to market. Additional terms may apply to the use or sale of other types of TI products and services.

Reproduction of significant portions of TI information in TI data sheets is permissible only if reproduction is without alteration and is accompanied by all associated warranties, conditions, limitations, and notices. TI is not responsible or liable for such reproduced documentation. Information of third parties may be subject to additional restrictions. Resale of TI products or services with statements different from or beyond the parameters stated by TI for that product or service voids all express and any implied warranties for the associated TI product or service and is an unfair and deceptive business practice. TI is not responsible or liable for any such statements.

Buyers and others who are developing systems that incorporate TI products (collectively, "Designers") understand and agree that Designers remain responsible for using their independent analysis, evaluation and judgment in designing their applications and that Designers have full and exclusive responsibility to assure the safety of Designers' applications and compliance of their applications (and of all TI products used in or for Designers' applications) with all applicable regulations, laws and other applicable requirements. Designer represents that, with respect to their applications, Designer has all the necessary expertise to create and implement safeguards that (1) anticipate dangerous consequences of failures, (2) monitor failures and their consequences, and (3) lessen the likelihood of failures that might cause harm and take appropriate actions. Designer agrees that prior to using or distributing any applications that include TI products, Designer will thoroughly test such applications and the functionality of such TI products as used in such applications.

TI's provision of technical, application or other design advice, quality characterization, reliability data or other services or information, including, but not limited to, reference designs and materials relating to evaluation modules, (collectively, "TI Resources") are intended to assist designers who are developing applications that incorporate TI products; by downloading, accessing or using TI Resources in any way, Designer (individually or, if Designer is acting on behalf of a company, Designer's company) agrees to use any particular TI Resource solely for this purpose and subject to the terms of this Notice.

TI's provision of TI Resources does not expand or otherwise alter TI's applicable published warranties or warranty disclaimers for TI products, and no additional obligations or liabilities arise from TI providing such TI Resources. TI reserves the right to make corrections, enhancements, improvements and other changes to its TI Resources. TI has not conducted any testing other than that specifically described in the published documentation for a particular TI Resource.

Designer is authorized to use, copy and modify any individual TI Resource only in connection with the development of applications that include the TI product(s) identified in such TI Resource. NO OTHER LICENSE, EXPRESS OR IMPLIED, BY ESTOPPEL OR OTHERWISE TO ANY OTHER TI INTELLECTUAL PROPERTY RIGHT, AND NO LICENSE TO ANY TECHNOLOGY OR INTELLECTUAL PROPERTY RIGHT OF TI OR ANY THIRD PARTY IS GRANTED HEREIN, including but not limited to any patent right, copyright, mask work right, or other intellectual property right relating to any combination, machine, or process in which TI products or services are used. Information regarding or referencing third-party products or services does not constitute a license to use such products or services, or a warranty or endorsement thereof. Use of TI Resources may require a license from a third party under the patents or other intellectual property of the third party, or a license from TI under the patents or other intellectual property of TI.

TI RESOURCES ARE PROVIDED "AS IS" AND WITH ALL FAULTS. TI DISCLAIMS ALL OTHER WARRANTIES OR REPRESENTATIONS, EXPRESS OR IMPLIED, REGARDING RESOURCES OR USE THEREOF, INCLUDING BUT NOT LIMITED TO ACCURACY OR COMPLETENESS, TITLE, ANY EPIDEMIC FAILURE WARRANTY AND ANY IMPLIED WARRANTIES OF MERCHANTABILITY, FITNESS FOR A PARTICULAR PURPOSE, AND NON-INFRINGEMENT OF ANY THIRD PARTY INTELLECTUAL PROPERTY RIGHTS. TI SHALL NOT BE LIABLE FOR AND SHALL NOT DEFEND OR INDEMNIFY DESIGNER AGAINST ANY CLAIM, INCLUDING BUT NOT LIMITED TO ANY INFRINGEMENT CLAIM THAT RELATES TO OR IS BASED ON ANY COMBINATION OF PRODUCTS EVEN IF DESCRIBED IN TI RESOURCES OR OTHERWISE. IN NO EVENT SHALL TI BE LIABLE FOR ANY ACTUAL, DIRECT, SPECIAL, COLLATERAL, INDIRECT, PUNITIVE, INCIDENTAL, CONSEQUENTIAL OR EXEMPLARY DAMAGES IN CONNECTION WITH OR ARISING OUT OF TI RESOURCES OR USE THEREOF, AND REGARDLESS OF WHETHER TI HAS BEEN ADVISED OF THE POSSIBILITY OF SUCH DAMAGES.

Unless TI has explicitly designated an individual product as meeting the requirements of a particular industry standard (e.g., ISO/TS 16949 and ISO 26262), TI is not responsible for any failure to meet such industry standard requirements.

Where TI specifically promotes products as facilitating functional safety or as compliant with industry functional safety standards, such products are intended to help enable customers to design and create their own applications that meet applicable functional safety standards and requirements. Using products in an application does not by itself establish any safety features in the application. Designers must ensure compliance with safety-related requirements and standards applicable to their applications. Designer may not use any TI products in life-critical medical equipment unless authorized officers of the parties have executed a special contract specifically governing such use. Life-critical medical equipment is medical equipment where failure of such equipment would cause serious bodily injury or death (e.g., life support, pacemakers, defibrillators, heart pumps, neurostimulators, and implantables). Such equipment includes, without limitation, all medical devices identified by the U.S. Food and Drug Administration as Class III devices and equivalent classifications outside the U.S.

TI may expressly designate certain products as completing a particular qualification (e.g., Q100, Military Grade, or Enhanced Product). Designers agree that it has the necessary expertise to select the product with the appropriate qualification designation for their applications and that proper product selection is at Designers' own risk. Designers are solely responsible for compliance with all legal and regulatory requirements in connection with such selection.

Designer will fully indemnify TI and its representatives against any damages, costs, losses, and/or liabilities arising out of Designer's non-compliance with the terms and provisions of this Notice.

Looking for pricing, stock, or lifecycle information?

Click below to explore more details on WIN SOURCE:

 [View LP3954TLX/NOPB on WIN SOURCE](#)

 [Texas Instruments](#) Information

Optimize Your Supply Chain with WIN SOURCE Solutions

-  Global Sourcing Solution
-  Obsolete Management
-  Cost Control Management
-  Shortage Management
-  Alternative Solution
-  Excess Inventory Management