



**THE DATASHEET OF
LP3929TMEX-AACQ**



LP3929 High Speed Bi-Directional Level Shifter and Ultra Low-Dropout CMOS Voltage Regulator and Line Protection

Check for Samples: [LP3929](#)

FEATURES

- Ultra Small DSBGA 24 Bump Package
- 6-signal Level Translation 1.8 V to 2.85 V
- LDO Stable with Ceramic and High Quality Tantalum Capacitors

KEY SPECIFICATIONS

- Level Shifter:
 - 6-Signal Level Shifter (5 Bi-Directional and 1 Uni-Direction)
 - 3 ns (Typ) Propagation Delay
 - Channel-to-Channel Skew < 1 ns (Max)
- Low-Dropout Regulator:
 - 3.05 V to 5.5 V Input Range
 - 2.85 V at 200 mA
 - Fast Turn-On Time: 30 μ s (Typ)
 - 110 mV (Max) Dropout with 200 mA Load
 - Thermal Shutdown at 160°C (Typ)
- Protection Block (B Side):
 - Robust IEC ESD Protection: ± 15 kV Air Gap, ± 8 kV Direct Contact
 - ASIP / EMI Filtering

DESCRIPTION

The LP3929 is designed for portable and wireless applications requiring level translation and power supply generation in a compact footprint.

The device level translates 1.8 V LVCMOS on the host (A) side to 2.85 V LVCMOS levels on the card (B) side for a miniSD / SD 4-bit bi-directional data bus.

Independent direct control of the CMD, Data0 and Data1-3 paths support mini SD state machine requirements. A shutdown pin is provided for the level shifters and regulator. The f_CLK_A is a feedback clock to the host which can be used to overcome level shifter bus delay.

The built-in low-dropout voltage regulator is ideal for mobile phone and battery powered wireless applications. It provides up to 200 mA from a 3.05 V to 5.5 V input. It is stable with small 1.0 μ F $\pm 30\%$ ceramic and high quality tantalum output capacitors, requiring smallest possible PC board area.

The card (B port) side channels have integration of ASIP (Application Specific Integrated Passives) - on chip integrated pull-up, pull-down, series resistors and capacitors for EMC filtering. It is designed to tolerate IEC61000-4-2 level 4 ESD: ± 15 kV air discharge, ± 8 kV direct contact.



Please be aware that an important notice concerning availability, standard warranty, and use in critical applications of Texas Instruments semiconductor products and disclaimers thereto appears at the end of this data sheet.

All trademarks are the property of their respective owners.

Typical Application Circuit

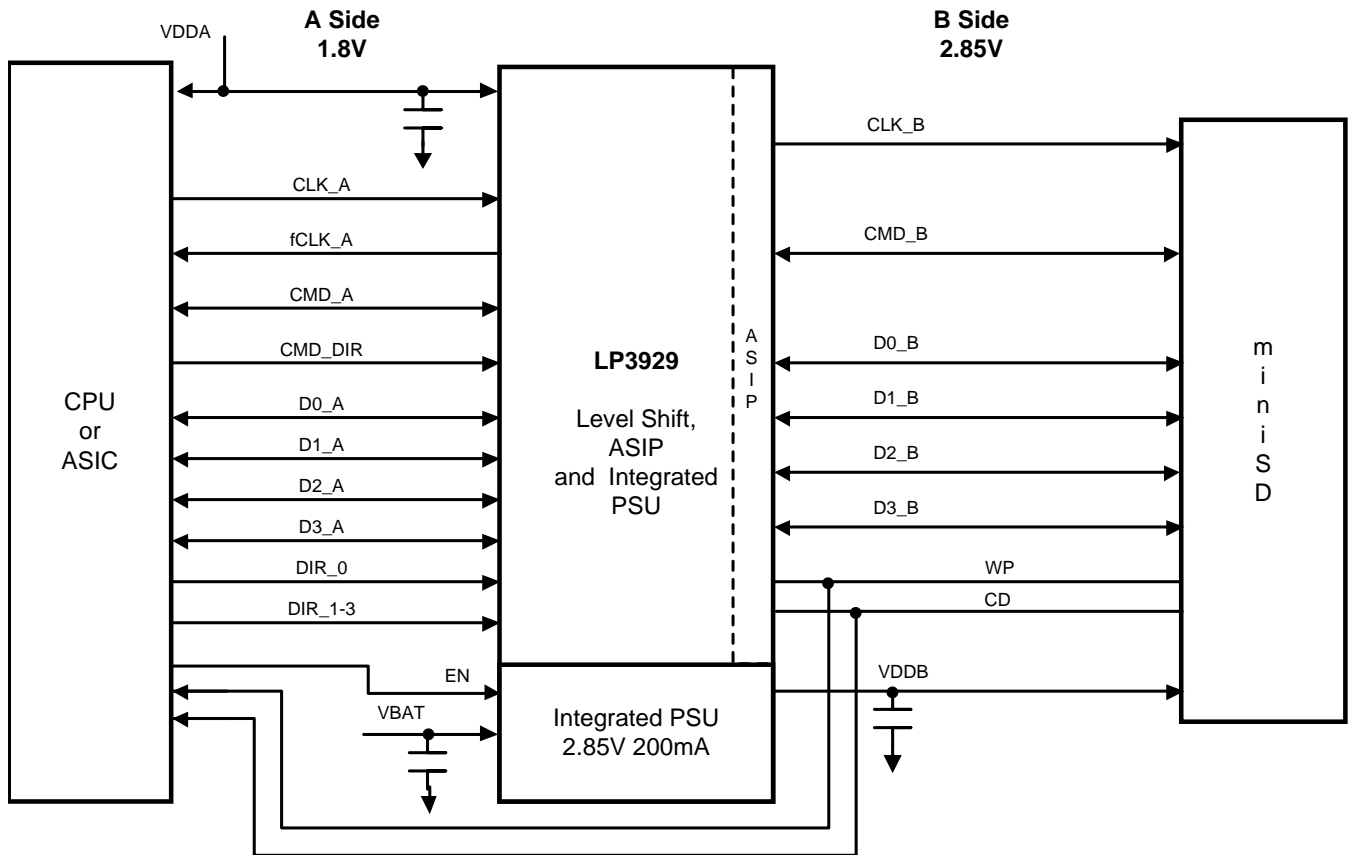

BLOCK DIAGRAM

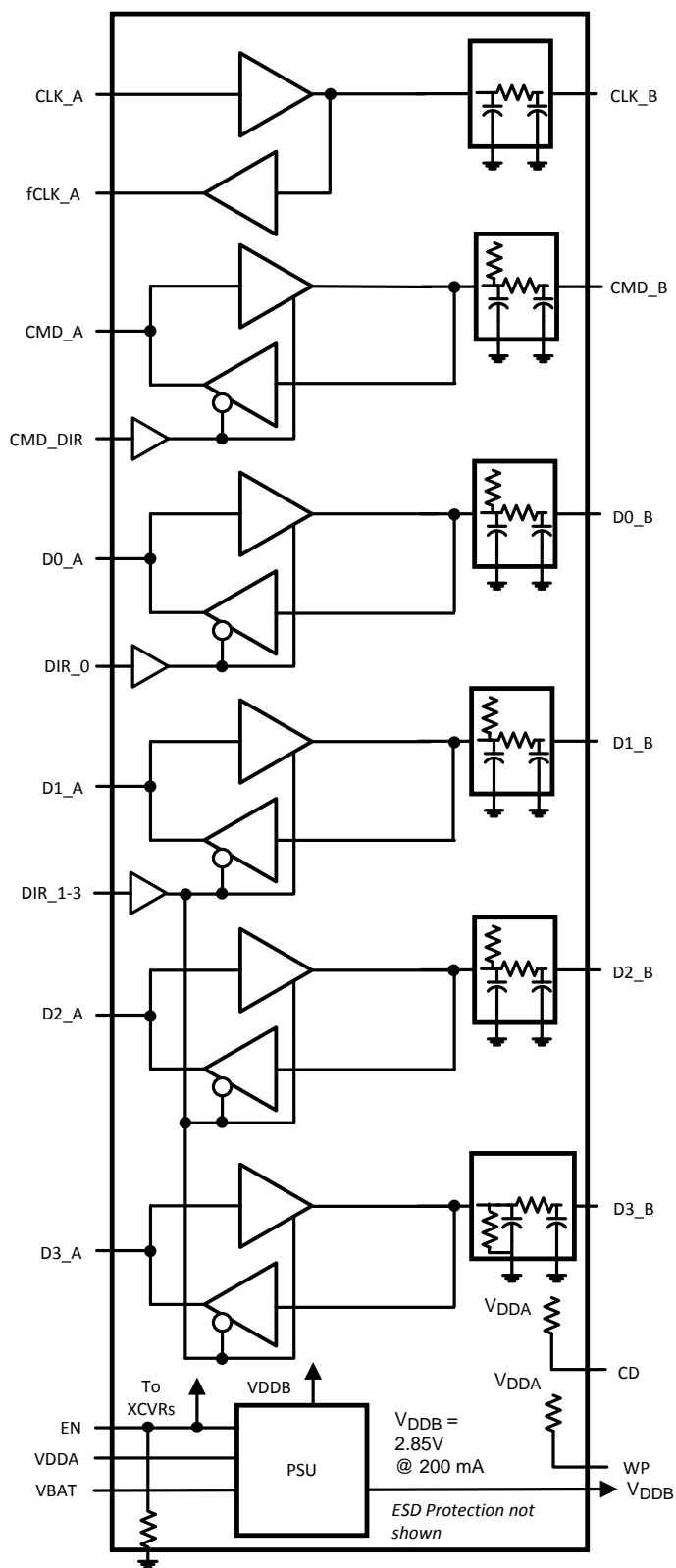

Package Outline

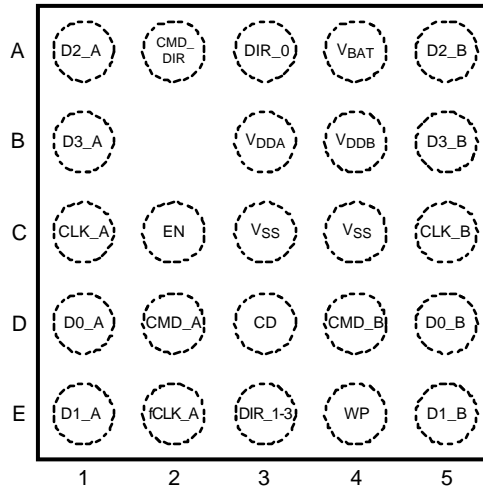

**Figure 1. Bump Underneath (Top View)
24 Bump DSBGA Package
See Package Number YFR0024AAA**

Tape and Reel Information

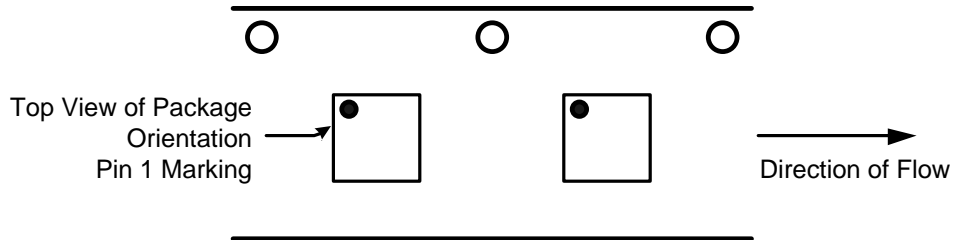

Figure 2. Tape and Reel Information (Top View)

Pin Descriptions

Pin Name	DSBGA Bump Identifier	Port / Direction	Type	Function
D0_A	D1	Host / Bidirectional	Push-Pull	1.8 V I/O Channel ⁽¹⁾
D1_A	E1	Host / Bidirectional	Push-Pull	1.8 V I/O Channel ⁽¹⁾
D2_A	A1	Host / Bidirectional	Push-Pull	1.8 V I/O Channel ⁽¹⁾
D3_A	B1	Host / Bidirectional	Push-Pull	1.8 V I/O Channel ⁽¹⁾
CMD_A	D2	Host / Bidirectional	Push-Pull	1.8 V I/O Channel ⁽¹⁾
CLK_A	C1	Host / Input	High Z	1.8 V Input CLK Channel ⁽¹⁾
fCLK_A	E2	Host / Output	Push-Pull	1.8 V Output CLK Channel
DIR_0	A3	Host / Input	High Z	1.8 V Input Direction Control D0 Channel: V _{DDA} = A → B Direction (Write), V _{SS} = B → A Direction (Read)
DIR_1-3	E3	Host / Input	High Z	1.8 V Input Direction Control D1-D3 Channel: V _{DDA} = A → B Direction (Write), V _{SS} = B → A Direction (Read)
CMD_DIR	A2	Host / Input	High Z	1.8 V Input Direction Control CMD Channel: V _{DDA} = A → B Direction (Write), V _{SS} = B → A Direction (Read)
EN	C2	Host / Input	High Z	Device Enable with high impedance pull-down resistor (200 kΩ): V _{DDA} = Device Active (on), V _{SS} = Device Disabled (off)
D0_B	D5	Card / Bidirectional	Push-Pull	2.85 V I/O Channel with high impedance pull-up to V _{DDB} (70 kΩ)
D1_B	E5	Card / Bidirectional	Push-Pull	2.85 V I/O Channel with high impedance pull-up to V _{DDB} (70 kΩ)
D2_B	A5	Card / Bidirectional	Push-Pull	2.85 V I/O Channel with high impedance pull-up to V _{DDB} (70 kΩ)
D3_B	B5	Card / Bidirectional	Push-Pull	2.85 V I/O Channel with high impedance pull-down to V _{SS} (470 kΩ)
CMD_B	D4	Card / Bidirectional	Push-Pull	2.85 V I/O Channel with high impedance pull-up to V _{DDB} (15 kΩ)
CLK_B	C5	Card / Output	Push-Pull	2.85 V Output CLK Channel
V _{BAT}	A4	Host / Input	Power	3.05 V to 5.5 V
V _{DDA}	B3	Host / Input	Power	1.71 V to 1.92 V, 1.8 V (typ)
V _{DDB}	B4	Card / Output	Power	2.85 V (LDO output)
V _{SS}	C3			Ground
V _{SS}	C4			Ground
WP	E4	Host / Card Input	Pull-up	Pull-up to V _{DDA} (100 kΩ)
CD	D3	Host / Card Input	Pull-up	Pull-up to V _{DDA} (100 kΩ)

(1) Unused inputs must be terminated.

Table 1. OPERATION MODES⁽¹⁾

Inputs				Mode
EN	CMD_DIR	DIR_0	DIR_1-3	
L	X	X	X	Level shifter / LDO = off (Shutdown Mode)
H	L	L	L	All channels (D0-D3 and CMD): B → A Direction
H	L	L	H	A → B Direction: D1-D3, B → A Direction: CMD and D0
H	L	H	L	A → B Direction: D0, B → A Direction: CMD and D1-D3
H	L	H	H	A → B Direction: D0-D3, B → A Direction: CMD
H	H	L	L	A → B Direction: CMD, B → A Direction: D0-D3
H	H	L	H	A → B Direction: CMD and D1-D3, B → A Direction: D0
H	H	H	L	A → B Direction: CMD and D0, B → A Direction: D1-D3
H	H	H	H	All channels (D0-D3 and CMD): A → B Direction

(1) H = V_{DDA} , L = V_{SS} 

These devices have limited built-in ESD protection. The leads should be shorted together or the device placed in conductive foam during storage or handling to prevent electrostatic damage to the MOS gates.

ABSOLUTE MAXIMUM RATINGS⁽¹⁾⁽²⁾

Supply Voltage (V_{BAT})		-0.3V to +6.0V
Supply Voltage (V_{DDA})		-0.3V to +3.3V
LVC MOS A Port Input Voltage		-0.3V to $V_{DDA} + 0.3V$
LVC MOS A Port I/O Voltage		-0.3V to $V_{DDA} + 0.3V$
LVC MOS B Port I/O Voltage		-0.3V to $V_{DDB} + 0.3V$
Junction Temperature		150°C
Storage Temperature		-65°C to +150°C
Lead Temperature ⁽³⁾		235°C
Pad Temperature ⁽³⁾		235°C
Derate DSBGA Package above 25°C		22.9 mW/°C
Maximum Power Dissipation Capacity at 25°C	DSBGA	2.8 W
ESD Rating	HBM - MIL-STD-883E 3015.7 std.	± 2kV
	MM - JESD22-A115-A std.	± 200V
	CDM - 500V (JESD22-C 101) Std.	± 500V
	IEC61000-4-2 std., 330Ω, 150pF, Air Gap, B Side ⁽⁴⁾	± 15kV
	IEC61000-4-2 std., 330Ω, 150pF, Direct Contact, B Side ⁽⁴⁾	± 8kV

- (1) **ABSOLUTE MAXIMUM RATINGS** are those values beyond which the safety of the device cannot be ensured. They are not meant to imply that the device should be operated at these limits. The tables of **ELECTRICAL CHARACTERISTICS** specify conditions for device operation.
- (2) If Military/Aerospace specified devices are required, please contact the Texas Instruments Sales Office/ Distributors for availability and specifications.
- (3) Additional information on lead temperature and pad temperature can be found in Texas Instruments Application Note (AN-1112).
- (4) IEC61000-4-2 level 4 ESD tolerance applies to V_{DDB} , D0_B–D3_B, CMD_B, CLK_B, WP and CP pins only. Device is tested in application (common ground, bypass capacitors of 1.0 μF present on V_{BAT} , V_{DDA} and V_{DDB}).

OPERATING CONDITIONS

V_{BAT} to V_{SS}	3.05V to 5.5V
V_{DDA} to V_{SS}	1.71V to 1.92V
Ambient Temperature	-30°C to +85°C

ELECTRICAL CHARACTERISTICS

Unless otherwise specified: $C_{VBAT} = 1 \mu\text{F}$, $I_{OUT} = 1 \text{ mA}$, $C_{VDDB} = 1 \mu\text{F}$, $C_{VDDA} = 1 \mu\text{F}$. Typical values and limits appearing in standard typeface apply for $T_A = 25^\circ\text{C}$. Limits appearing in **boldface type** apply over the entire ambient temperature range for operation, -30°C to $+85^\circ\text{C}$. ⁽¹⁾⁽²⁾

Symbol	Parameter	Conditions	Min	Typ	Max	Units	
LVC MOS A (Host) Port ($V_{DDA} = 1.71\text{V}$ to 1.92V)							
V_{IH}	Input Voltage High Level		$0.65 \times V_{DDA}$		1.92	V	
		$V_{DDA} = 1.71\text{V}$	1.1115		1.92	V	
		$V_{DDA} = 1.92\text{V}$	1.248		1.92	V	
V_{IL}	Input Voltage Low Level		0		$0.30 \times V_{DDA}$	V	
		$V_{DDA} = 1.71\text{V}$	0		0.513	V	
		$V_{DDA} = 1.92\text{V}$	0		0.576	V	
I_{IH}	Input Current High Level	$V_{IH} = V_{DDA}$		0	+1	μA	
		$EN = V_{SS}$	-1	0	+1	μA	
		$EN = V_{DDA}$	-1	0	+10	μA	
I_{IL}	Input Current Low Level	$V_{IL} = V_{SS}$	-1	0	+1	μA	
V_{OH}	Output Voltage High Level	$I_{OH} = -4 \text{ mA}$	1.26	1.8	V_{DDA}	V	
V_{OL}	Output Voltage Low Level	$I_{OL} = 4 \text{ mA}$	V_{SS}	0	0.45	V	
LVC MOS B (Card) Port ($V_{DDB} = 2.85\text{V}$)							
V_{IH}	Input Voltage High Level		$0.65 \times V_{DDB}$		V_{DDB}	V	
V_{IL}	Input Voltage Low Level		0		$0.35 \times V_{DDB}$	V	
I_{IH}	Input Current High Level	$V_{IH} = V_{DDB}$		0.2	+2	μA	
		D0_B to D2_B	-2	6.5	+13	μA	
		D3_B	0	0.3	+5	μA	
I_{IL}	Input Current Low Level	$V_{IL} = V_{SS}$		-40	0	μA	
		D0_B to D2_B	-80	0.1	+1	μA	
		D3_B	-1	-200	-20	μA	
IOS +	Short Circuit Current	$V_{OUTlow} = V_{DDB}$		45		μA	
		$V_{OUThigh} = V_{SS}$		-20		μA	
IOS -						μA	
V_{OH}	Output Voltage High Level	$I_{OH} = -2 \text{ mA}$	$0.75 \times V_{DDB}$			V	
V_{OL}	Output Voltage Low Level	$I_{OL} = 2 \text{ mA}$			$0.25 \times V_{DDB}$	V	
Supply Current							
I_{DD}	Supply Current	All Channels Static: A → B mode, LDO unloaded	V_{BAT}		4	7	mA
			V_{DDA}		95	200	μA
I_{DDZ}	Supply Current — Shutdown	$EN = V_{SS}$	V_{BAT}		0.1	2	μA
			V_{DDA}		0.2	2	μA
C_{OUT}	Output Capacitance ⁽³⁾	B (card) port			15	20	pF

(1) Typical values are given for $V_{DDA} = 1.8\text{V}$, $V_{BAT} = 3.6\text{V}$, $T_A = 25^\circ\text{C}$

(2) Current into device pins is defined as positive. Current out of device pins is defined as negative. Voltages are reference to ground unless otherwise specified.

(3) This electrical specification is ensured by design.

LEVEL SHIFTER AC SWITCHING CHARACTERISTICS

Unless otherwise specified: $C_{VBAT} = 1 \mu\text{F}$, $I_{OUT} = 1 \text{ mA}$, $C_{VDDB} = 1 \mu\text{F}$, $C_{VDDA} = 1 \mu\text{F}$. Typical values and limits appearing in standard typeface apply for $T_A = 25^\circ\text{C}$. Limits appearing in **boldface type** apply over the entire ambient temperature range for operation, -30°C to $+85^\circ\text{C}$. ⁽¹⁾⁽²⁾⁽³⁾⁽⁴⁾

Symbol	Parameter	Conditions	Min	Typ	Max	Units
t_{PLH}	Propagation Delay A to B or B to A	$C_{LB} = 15 \text{ pF}$, $C_{LA} = 20 \text{ pF}$, 50%-50%		3	7	ns
	Propagation Delay CLK_A to fCLK_A	$C_{LA} = 20 \text{ pF}$, 50%-50%		5	14	ns
t_{PHL}	Propagation Delay A to B or B to A	$C_{LB} = 15 \text{ pF}$, $C_{LA} = 20 \text{ pF}$, 50%-50%		3	7	ns
	Propagation Delay CLK_A to fCLK_A	$C_{LA} = 20 \text{ pF}$, 50%-50%		5	14	ns
t_{RISE}	Rise Time A Side Output, see Figure 4	$C_{LA} = 20 \text{ pF}$, 20%-70%		1.1	3	ns
	Rise Time B Side Output with ASIP, see Figure 4	$C_{LB} = 15 \text{ pF}$, 20%-70%		1.6	3	ns
t_{FALL}	Fall Time A Side Output, see Figure 4	$C_{LA} = 20 \text{ pF}$, 20%-70%		1.0	3	ns
	Fall Time B Side Output with ASIP, see Figure 4	$C_{LB} = 15 \text{ pF}$, 20%-70%		1.9	3	ns
t_{SKEW}	Skew between D0–D3, CLK and CMD outputs (either edge)			<0.5	1.0	ns
t_{EN}	Enable Time			30	200	μs
t_{DIS}	Disable Time			18	50	ns
t_{TA}	Level-Shifter Direction Switch Response (Turn Around) Time			13	20	ns

- (1) Typical values are given for $V_{DDA} = 1.8\text{V}$, $V_{BAT} = 3.6\text{V}$, $T_A = 25^\circ\text{C}$
- (2) Input signal for test purpose is defined as: A side – 0V to 1.8V with 2ns rise time (20%-70%) and B side – 0V to 2.85V with 2ns rise time (20%-70%)
- (3) This electrical specification is ensured by design.
- (4) The SD/MMC card specification calls for a total of 30 pF capacitance. A load of 15 pF is internal to the LP3929, so the external load capacitance on the B side should comprise the remaining (15 pF or less).

LDO ELECTRICAL CHARACTERISTICS

Unless otherwise specified: $C_{VBAT} = 1 \mu\text{F}$, $I_{OUT} = 1 \text{ mA}$, $C_{VDDB} = 1 \mu\text{F}$, $C_{VDDA} = 1 \mu\text{F}$. Typical values and limits appearing in standard typeface apply for $T_A = 25^\circ\text{C}$. Limits appearing in **boldface type** apply over the entire ambient temperature range for operation, -30°C to $+85^\circ\text{C}$.⁽¹⁾

Symbol	Parameter	Conditions	Min	Typ	Max	Units
V_{OUT}	Output Voltage, $V_{OUT} = V_{DDB}$	$I_{OUT} = 200\text{mA}$, $V_{BAT} = 3.05\text{V}$ to 5.5V	2.76	2.85	2.93	V
ΔV_{OUT}	Output Voltage Tolerance	$I_{OUT} = 1 \text{ mA}$	-2 -3		2 3	% of $V_{OUT(nom)}$
	Line Regulation Error ⁽²⁾	$V_{BAT} = (V_{OUT(nom)} + 0.5\text{V})$ to 5.5V , $I_{OUT} = 1 \text{ mA}$	-0.15		0.15	%/V
	Load Regulation Error ⁽³⁾	$I_{OUT} = 1 \text{ mA}$ to 200 mA	-0.01		0.01	%/mA
	Output AC Line Regulation	$V_{BAT} = V_{OUT(nom)} + 1\text{V}$, $I_{OUT} = 100 \text{ mA}$, $C_{OUT} = 1.0 \mu\text{F}$		1.5		mV _{PP}
PSRR	Power Supply Rejection Ratio ⁽⁴⁾	$V_{BAT} = V_{OUT(nom)} + 1\text{V}$, $f = 1 \text{ kHz}$, $I_{OUT} = 50 \text{ mA}$		40		dB
		$V_{BAT} = V_{OUT(nom)} + 1\text{V}$, $f = 10 \text{ kHz}$, $I_{OUT} = 50 \text{ mA}$		30		
ΔV_{DO}	Dropout Voltage ⁽⁵⁾	$I_{OUT} = 1 \text{ mA}$		1		mV
		$I_{OUT} = 50 \text{ mA}$		20		
		$I_{OUT} = 100 \text{ mA}$		35		
		$I_{OUT} = 200 \text{ mA}$		60	110	
I_{SC}	Short Circuit Current Limit	$V_{BAT} = 5.5\text{V}$, Output Grounded (Steady State)		750		mA
T_{ON}	Turn-On Time ⁽⁴⁾⁽⁶⁾			30	200	μs
ρ_n (1/f)	Output Noise Density	$f = 1 \text{ kHz}$, $C_{OUT} = 1.0 \mu\text{F}$		0.6		$\mu\text{V}/\sqrt{\text{Hz}}$
e_n	Output Noise Voltage	$\text{BW} = 10 \text{ Hz}$ to 100 kHz , $C_{OUT} = 1.0 \mu\text{F}$		45		μV_{RMS}
Output Capacitor	Output Filter Capacitance ⁽⁷⁾	$V_{BAT} = 3.05\text{V}$ to 5.5V , $I_{OUT} = 1\text{mA}$ to 200 mA	0.7	1.0	22	μF
	Output Filter Capacitance ESR ⁽⁸⁾	$V_{BAT} = 3.05\text{V}$ to 5.5V , $I_{OUT} = 1\text{mA}$ to 200mA	5		500	m Ω
Thermal Shutdown	Thermal Shutdown Temperature ⁽⁴⁾⁽⁹⁾	$V_{BAT} = 3.05\text{V}$ to 5.5V , $I_{OUT} = 1\text{mA}$ to 200mA		160		$^\circ\text{C}$
	Thermal Shutdown Hysteresis ⁽⁴⁾			20		$^\circ\text{C}$

- (1) Typical values are given for $V_{DDB} = 1.8\text{V}$, $V_{BAT} = 3.6\text{V}$, $T_A = 25^\circ\text{C}$
- (2) The output voltage changes slightly with line voltage. An increase in the line voltage results in a slight increase in the output voltage and vice versa.
- (3) The output voltage changes slightly with load current. An increase in the load current results in a slight decrease in the output voltage and vice versa.
- (4) This electrical specification is ensured by design.
- (5) Dropout voltage is the input-to-output voltage difference at which the output voltage is 100 mV below its nominal value. This specification does not apply for input voltages below 2.7V.
- (6) Turn-on time is that between when the enable input is high and the output voltage just reaching 95% of its nominal value.
- (7) Range of capacitor value for which the device will remain stable. This electrical specification is ensured by design.
- (8) Range of capacitor ESR values for which the device will remain stable. This electrical specification is ensured by design.
- (9) The built-in thermal shut-down of the LDO is also used to put all A and B outputs in tri-state mode.

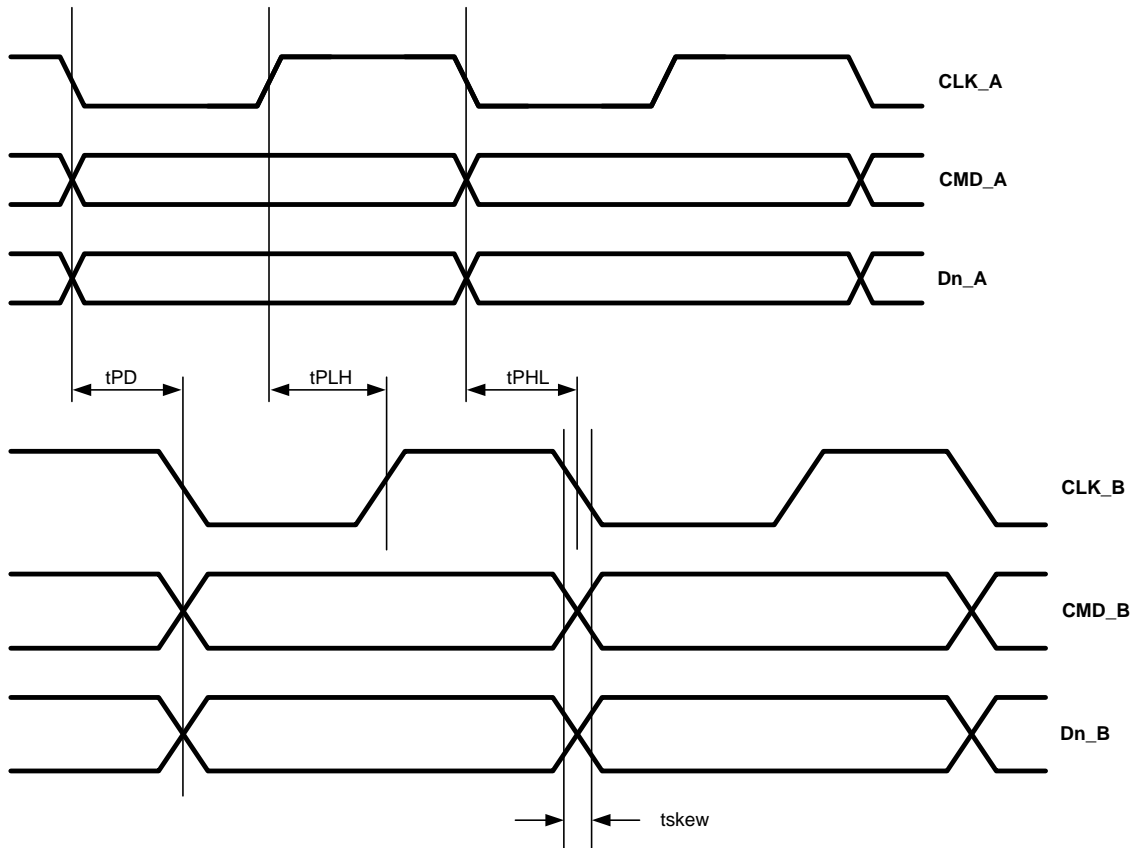

Figure 3. A to B Timing Diagram (propagation delay, skew)



Figure 4. Output Transition Time (A and B Side)

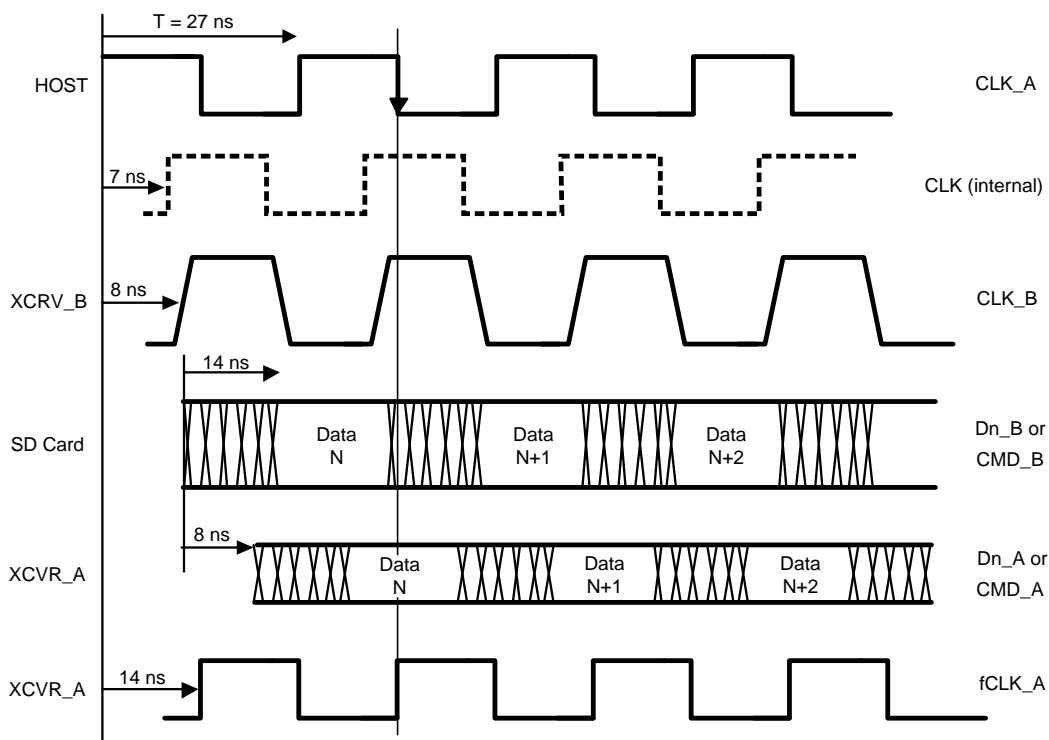

Figure 5. B to A Direction (37 MHz Example)

TYPICAL PERFORMANCE CHARACTERISTICS

Unless otherwise specified: $C_{VBAT} = 1\ \mu\text{F}$, $C_{VDDA} = 1\ \mu\text{F}$, $C_{VDDb} = 1\ \mu\text{F}$, $V_{BAT} = 3.85\text{ V}$, $V_{DDA} = 1.8\text{ V}$, $T_A = 25^\circ\text{C}$.

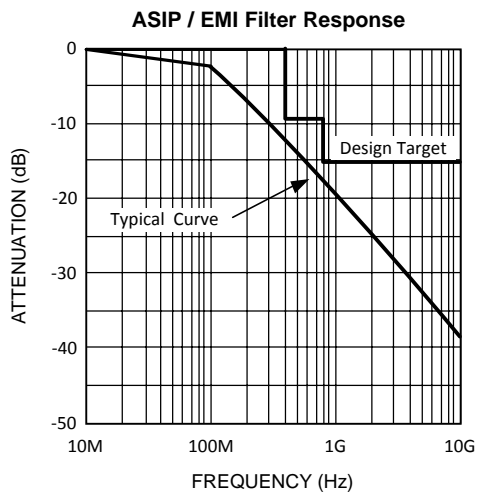

Figure 6.

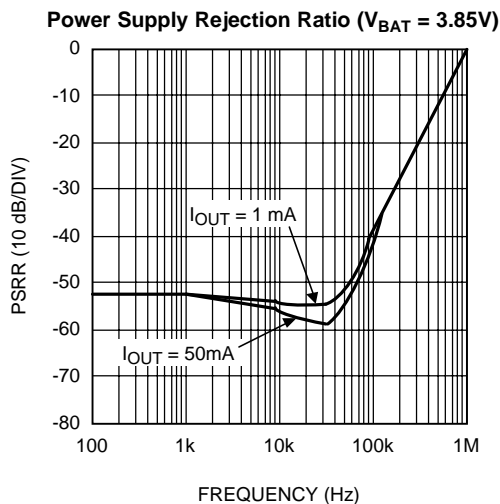

Figure 7.

APPLICATION INFORMATION

EXTERNAL CAPACITORS

Like any low-dropout regulator, the LP3929 requires external capacitors for regulator stability. The LP3929 is specifically designed for portable applications requiring minimum board space and smallest components. These capacitors must be correctly selected for good performance.

INPUT CAPACITOR

An input capacitance of 1 μF is required between the LP3929 V_{BAT} pin and ground (the amount of the capacitance may be increased without limit).

This capacitor must be located a distance of not more than 1 cm from the V_{BAT} pin and returned to a clean analog ground. Any good quality ceramic, tantalum, or film capacitor may be used at the input.

Important: Tantalum capacitors can suffer catastrophic failures due to surge current when connected to a low-impedance source of power (like a battery or a very large capacitor). If a tantalum capacitor is used at the input, it must be ensured by the manufacturer to have a surge current rating sufficient for the application.

There are no requirements for the ESR on the input capacitor, but tolerance, bias voltage and temperature coefficient must be considered when selecting the capacitor to ensure the capacitance will be 1 μF over the entire operating conditions.

FAST ON-TIME

The LP3929 utilizes a speed up circuitry to ramp up the internal V_{REF} voltage to its final value to achieve a fast output turn on time.

CAPACITOR CHARACTERISTICS

The LP3929 is designed to work with ceramic capacitors on the output to take advantage of the benefits they offer: for capacitance values in the range of 1 μF to 4.7 μF range, ceramic capacitors are the smallest, least expensive and have the lowest ESR values (which makes them best for eliminating high frequency noise). The ESR of a typical 1 μF ceramic capacitor is in the range of 20 m Ω to 40 m Ω , which easily meets the ESR requirement for stability of the LP3929.

The ceramic capacitor's capacitance can vary with temperature.

Most large value ceramic capacitors (2.2 μF) are manufactured with Z5U or Y5V temperature characteristics, which results in the capacitance dropping by more than 50% as the temperature goes from 25°C to 85°C.

A better choice for temperature coefficient in ceramic capacitor is X7R, which holds the capacitance within $\pm 15\%$.

Tantalum capacitors are less desirable than ceramic for use as output capacitors because they are more expensive when comparing equivalent capacitance and voltage ratings in the 1 μF to 4.7 μF range.

Another important consideration is that tantalum capacitors have higher ESR values than equivalent size ceramics. This means that while it may be possible to find a tantalum capacitor with an ESR value within the stable range, it would have to be larger in capacitance (which means bigger and more costly) than a ceramic capacitor with the same ESR value. It should also be noted that the ESR of a typical tantalum will increase about 2:1 as the temperature goes from 25°C down to -40°C, so some guard band must be allowed.

OUTPUT CAPACITOR

The LP3929 is designed specifically to work with very small ceramic output capacitors, any ceramic capacitor (dielectric types Z5U, Y5V or X7R) in 1.0 μF to 2.2 μF range with 5 m Ω to 500 m Ω ESR range is suitable in the LP3929 application circuit.

It may also be possible to use tantalum or film capacitors at the output, but these are not as attractive for reasons of size and cost (see section [CAPACITOR CHARACTERISTICS](#)).

The output capacitor must meet the requirement for minimum amount of capacitance and also have an ESR (Equivalent Series Resistance) value which is within a stable range.

The output capacitor should be placed as near as possible to the V_{DDB} pin.

NO-LOAD STABILITY

The LDO of the LP3929 will remain stable and in regulation with no external load connected to the LDO output V_{DDB} . This is especially important in CMOS RAM keep-alive applications.

DSBGA ASSEMBLY

For assembly recommendations of DSBGA package please refer to Texas Instruments Application Note [AN-1112](#).

DSBGA LIGHT SENSITIVITY

Exposing the DSBGA device to direct sunlight will cause misoperation of the device. Light sources such as Halogen lamps can effect electrical performance if brought near to the device.

The wavelengths which have most detrimental effect are reds and infra-reds, which means that the fluorescent lighting used inside most buildings has very little effect on performance.

REVISION HISTORY

Changes from Revision B (May 2013) to Revision C	Page
• Changed layout of National Data Sheet to TI format	13

PACKAGING INFORMATION

Orderable Device	Status (1)	Package Type	Package Drawing	Pins	Package Qty	Eco Plan (2)	Lead/Ball Finish (6)	MSL Peak Temp (3)	Op Temp (°C)	Device Marking (4/5)	Samples
LP3929TME-AACQ/NOPB	ACTIVE	DSBGA	YFR	24		TBD	Call TI	Call TI		D57B	Samples
LP3929TMEX-AACQ/NOPB	ACTIVE	DSBGA	YFR	24		TBD	Call TI	Call TI		D57B	Samples

(1) The marketing status values are defined as follows:

ACTIVE: Product device recommended for new designs.

LIFEBUY: TI has announced that the device will be discontinued, and a lifetime-buy period is in effect.

NRND: Not recommended for new designs. Device is in production to support existing customers, but TI does not recommend using this part in a new design.

PREVIEW: Device has been announced but is not in production. Samples may or may not be available.

OBSOLETE: TI has discontinued the production of the device.

(2) Eco Plan - The planned eco-friendly classification: Pb-Free (RoHS), Pb-Free (RoHS Exempt), or Green (RoHS & no Sb/Br) - please check <http://www.ti.com/productcontent> for the latest availability information and additional product content details.

TBD: The Pb-Free/Green conversion plan has not been defined.

Pb-Free (RoHS): TI's terms "Lead-Free" or "Pb-Free" mean semiconductor products that are compatible with the current RoHS requirements for all 6 substances, including the requirement that lead not exceed 0.1% by weight in homogeneous materials. Where designed to be soldered at high temperatures, TI Pb-Free products are suitable for use in specified lead-free processes.

Pb-Free (RoHS Exempt): This component has a RoHS exemption for either 1) lead-based flip-chip solder bumps used between the die and package, or 2) lead-based die adhesive used between the die and leadframe. The component is otherwise considered Pb-Free (RoHS compatible) as defined above.

Green (RoHS & no Sb/Br): TI defines "Green" to mean Pb-Free (RoHS compatible), and free of Bromine (Br) and Antimony (Sb) based flame retardants (Br or Sb do not exceed 0.1% by weight in homogeneous material)

(3) MSL, Peak Temp. - The Moisture Sensitivity Level rating according to the JEDEC industry standard classifications, and peak solder temperature.

(4) There may be additional marking, which relates to the logo, the lot trace code information, or the environmental category on the device.

(5) Multiple Device Markings will be inside parentheses. Only one Device Marking contained in parentheses and separated by a "~" will appear on a device. If a line is indented then it is a continuation of the previous line and the two combined represent the entire Device Marking for that device.

(6) Lead/Ball Finish - Orderable Devices may have multiple material finish options. Finish options are separated by a vertical ruled line. Lead/Ball Finish values may wrap to two lines if the finish value exceeds the maximum column width.

Important Information and Disclaimer: The information provided on this page represents TI's knowledge and belief as of the date that it is provided. TI bases its knowledge and belief on information provided by third parties, and makes no representation or warranty as to the accuracy of such information. Efforts are underway to better integrate information from third parties. TI has taken and continues to take reasonable steps to provide representative and accurate information but may not have conducted destructive testing or chemical analysis on incoming materials and chemicals. TI and TI suppliers consider certain information to be proprietary, and thus CAS numbers and other limited information may not be available for release.

In no event shall TI's liability arising out of such information exceed the total purchase price of the TI part(s) at issue in this document sold by TI to Customer on an annual basis.

YFR0024

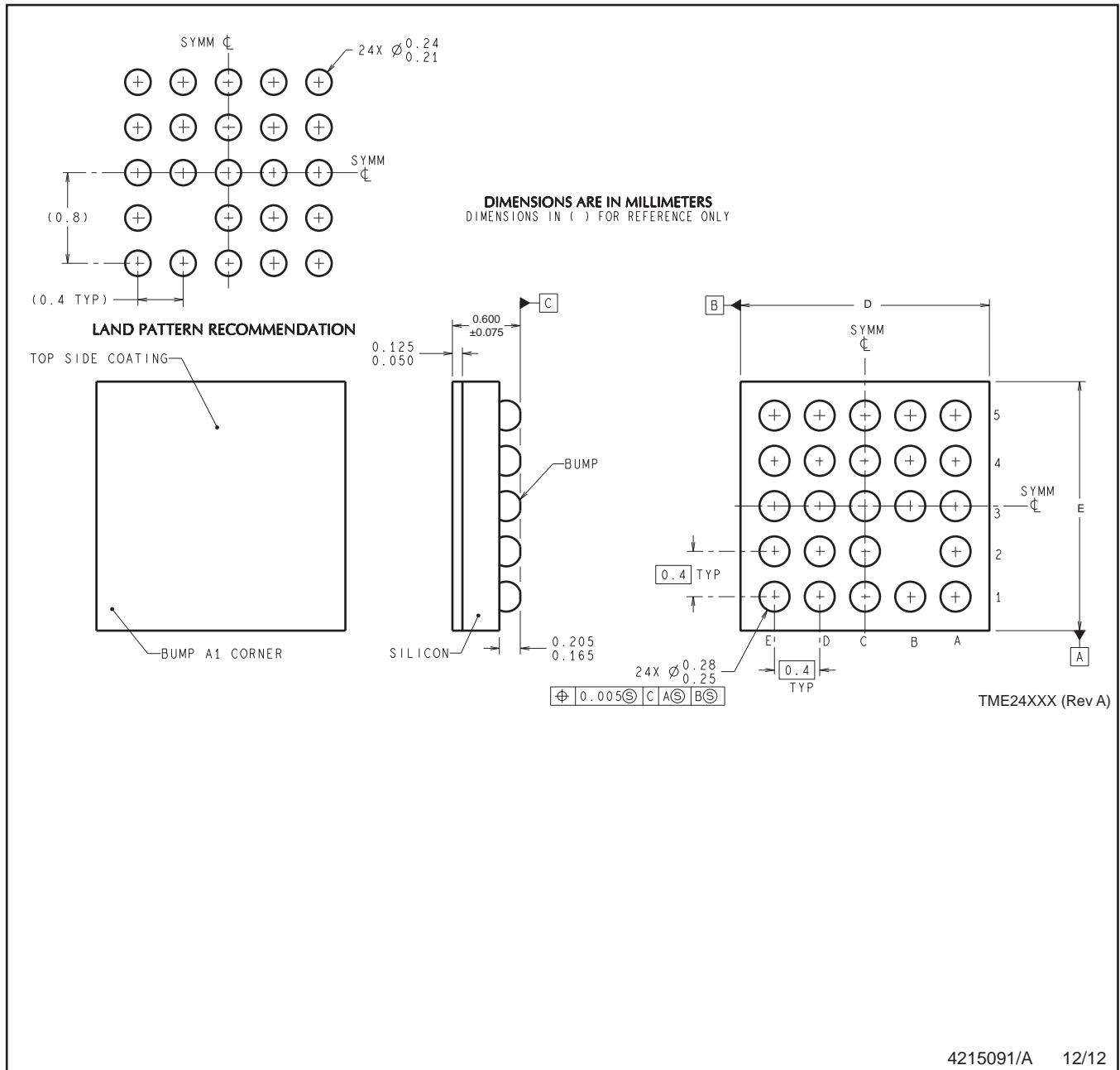

NOTES: A. All linear dimensions are in millimeters. Dimensioning and tolerancing per ASME Y14.5M-1994.
B. This drawing is subject to change without notice.

IMPORTANT NOTICE

Texas Instruments Incorporated and its subsidiaries (TI) reserve the right to make corrections, enhancements, improvements and other changes to its semiconductor products and services per JESD46, latest issue, and to discontinue any product or service per JESD48, latest issue. Buyers should obtain the latest relevant information before placing orders and should verify that such information is current and complete. All semiconductor products (also referred to herein as "components") are sold subject to TI's terms and conditions of sale supplied at the time of order acknowledgment.

TI warrants performance of its components to the specifications applicable at the time of sale, in accordance with the warranty in TI's terms and conditions of sale of semiconductor products. Testing and other quality control techniques are used to the extent TI deems necessary to support this warranty. Except where mandated by applicable law, testing of all parameters of each component is not necessarily performed.

TI assumes no liability for applications assistance or the design of Buyers' products. Buyers are responsible for their products and applications using TI components. To minimize the risks associated with Buyers' products and applications, Buyers should provide adequate design and operating safeguards.

TI does not warrant or represent that any license, either express or implied, is granted under any patent right, copyright, mask work right, or other intellectual property right relating to any combination, machine, or process in which TI components or services are used. Information published by TI regarding third-party products or services does not constitute a license to use such products or services or a warranty or endorsement thereof. Use of such information may require a license from a third party under the patents or other intellectual property of the third party, or a license from TI under the patents or other intellectual property of TI.

Reproduction of significant portions of TI information in TI data books or data sheets is permissible only if reproduction is without alteration and is accompanied by all associated warranties, conditions, limitations, and notices. TI is not responsible or liable for such altered documentation. Information of third parties may be subject to additional restrictions.

Resale of TI components or services with statements different from or beyond the parameters stated by TI for that component or service voids all express and any implied warranties for the associated TI component or service and is an unfair and deceptive business practice. TI is not responsible or liable for any such statements.

Buyer acknowledges and agrees that it is solely responsible for compliance with all legal, regulatory and safety-related requirements concerning its products, and any use of TI components in its applications, notwithstanding any applications-related information or support that may be provided by TI. Buyer represents and agrees that it has all the necessary expertise to create and implement safeguards which anticipate dangerous consequences of failures, monitor failures and their consequences, lessen the likelihood of failures that might cause harm and take appropriate remedial actions. Buyer will fully indemnify TI and its representatives against any damages arising out of the use of any TI components in safety-critical applications.

In some cases, TI components may be promoted specifically to facilitate safety-related applications. With such components, TI's goal is to help enable customers to design and create their own end-product solutions that meet applicable functional safety standards and requirements. Nonetheless, such components are subject to these terms.

No TI components are authorized for use in FDA Class III (or similar life-critical medical equipment) unless authorized officers of the parties have executed a special agreement specifically governing such use.

Only those TI components which TI has specifically designated as military grade or "enhanced plastic" are designed and intended for use in military/aerospace applications or environments. Buyer acknowledges and agrees that any military or aerospace use of TI components which have **not** been so designated is solely at the Buyer's risk, and that Buyer is solely responsible for compliance with all legal and regulatory requirements in connection with such use.

TI has specifically designated certain components as meeting ISO/TS16949 requirements, mainly for automotive use. In any case of use of non-designated products, TI will not be responsible for any failure to meet ISO/TS16949.

Products

Audio	www.ti.com/audio
Amplifiers	amplifier.ti.com
Data Converters	dataconverter.ti.com
DLP® Products	www.dlp.com
DSP	dsp.ti.com
Clocks and Timers	www.ti.com/clocks
Interface	interface.ti.com
Logic	logic.ti.com
Power Mgmt	power.ti.com
Microcontrollers	microcontroller.ti.com
RFID	www.ti-rfid.com
OMAP Applications Processors	www.ti.com/omap
Wireless Connectivity	www.ti.com/wirelessconnectivity

Applications

Automotive and Transportation	www.ti.com/automotive
Communications and Telecom	www.ti.com/communications
Computers and Peripherals	www.ti.com/computers
Consumer Electronics	www.ti.com/consumer-apps
Energy and Lighting	www.ti.com/energy
Industrial	www.ti.com/industrial
Medical	www.ti.com/medical
Security	www.ti.com/security
Space, Avionics and Defense	www.ti.com/space-avionics-defense
Video and Imaging	www.ti.com/video

TI E2E Community

e2e.ti.com

Looking for pricing, stock, or lifecycle information?

Click below to explore more details on WIN SOURCE:

 [View LP3929TMEX-AACQ on WIN SOURCE](#)

 [Texas Instruments](#) Information

Optimize Your Supply Chain with WIN SOURCE Solutions

-  Global Sourcing Solution
-  Obsolete Management
-  Cost Control Management
-  Shortage Management
-  Alternative Solution
-  Excess Inventory Management