



**THE DATASHEET OF
LP3918TL-A/NOPB**



LP3918 Battery Charge Management and Regulator Unit

Check for Samples: [LP3918](#)

FEATURES

- Fully Integrated Li-Ion Battery Charger with Thermal Regulation
- USB Charge Mode
- 7 Low Noise LDO's
 - 2 x 300 mA
 - 3 x 150 mA
 - 2 x 80 mA
- I2C Compatible Interface for Controlling LDO Outputs and Charger Operation
- Thermal Shutdown
- Under Voltage Lockout
- 25-Bump Thin DSBGA Package 2.5 x 2.5 mm
- Options Available on Request, Please Contact Sales Office for Further Information;
 - Level Detect on HF_PWR & PWR_ON
 - LDO Charging Mode
 - Custom Default Settings on Charger, and LDO O/P's.

APPLICATIONS

- CDMA Phone Handsets
- Low Power Wireless Handsets
- Handheld Information Appliances
- Personal Media Players
- Digital Cameras

Functional Block Diagram

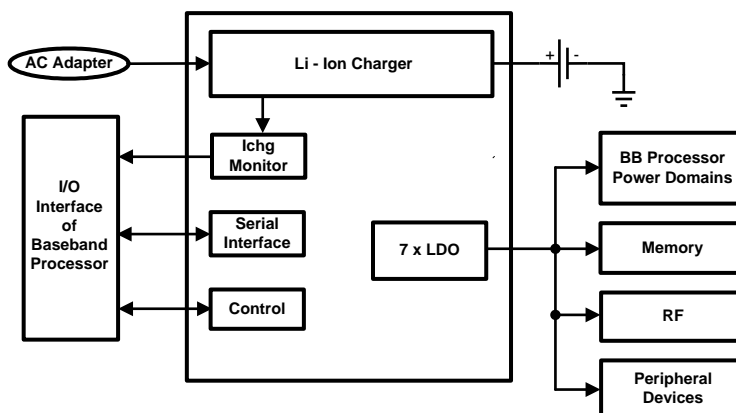

Figure 1. Simplified Functional Block Diagram



Please be aware that an important notice concerning availability, standard warranty, and use in critical applications of Texas Instruments semiconductor products and disclaimers thereto appears at the end of this data sheet.

All trademarks are the property of their respective owners.

KEY SPECIFICATIONS

- 50mA to 950mA Programmable Charge Current
- 3.0V to 5.5V Input Voltage Range
- 200mV Typ. Dropout Voltage on 300 mA LDO's
- 2% (Typ) Output Voltage Accuracy on LDO's

DESCRIPTION

The LP3918 is a fully integrated charger and multi-regulator unit designed for CDMA cellular phones. The LP3918 contains a Li-Ion battery charger, 7 low noise low dropout (LDO) voltage regulators and a high-speed serial interface to program on/off conditions and output voltages of individual regulators, and also to read status information from the PMU.

The Li-Ion charger integrates a power FET, reverse current blocking diode, sense resistor with current monitor output, and requires only a few external components. Charging is thermally regulated to obtain the most efficient charging rate for a given ambient temperature.

LDO regulators provide high PSRR and low noise ideally suited for supplying power to both analog and digital loads.

Device Pin Diagram

Figure 2. LP3918 25 pin DSBGA Package TOP VIEW

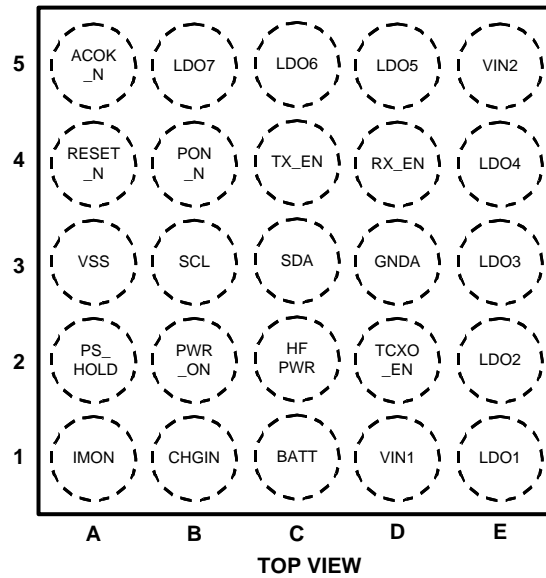

PIN DESCRIPTION

Pin #	Name	Type ⁽¹⁾	Description
A1	IMON	A	Charge current monitor output. This pin presents an analog voltage representation of the input charging current. $V_{IMON}(mV) = (2.47 \times I_{CHG})(mA)$.
A2	PS_HOLD	DI	Input for power control from external processor/controller.
A3	VSS	G	Digital Ground pin
A4	RESET_N	DO	Reset Output. Pin stays LOW during power up sequence. 60ms after LDO1 (CORE) is stable this pin is asserted HIGH.
A5	ACOK_N	DO	AC Adapter indicator, LOW when 4.5V – 6.0V present at CHG_IN.
B1	CHG_IN	P	DC power input to charger block from wall or car power adapters.
B2	PWR_ON	DI	Power up sequence starts when this pin is set HIGH. Internal 500kΩ pull-down resistor.
B3	SCL	DI	Serial Interface Clock input. External pull up resistor is needed, typ 1.5kΩ
B4	PON_N	DO	Active low signal is PWR_ON inverted
B5	LDO7	A	LDO7 Output (GP)
C1	BATT	P	Main battery connection. Used as a power connection for current delivery to the battery.
C2	HF_PWR	DI	Power up sequence starts when this pin is set HIGH. Internal 500kΩ pull-down resistor.
C3	SDA	DI/O	Serial Interface, Data Input/Output Open Drain output, external pull up resistor is needed, typ 1.5kΩ.
C4	TX_EN	DI	Enable control for LDO6 (TX). HIGH = Enable, LOW = Disable.
C5	LDO6	A	LDO6 Output (TX)
D1	VIN1	P	Battery Input for LDO1 - 2
D2	TCXO_EN	DI	Enable control for LDO4 (TCXO). HIGH = Enable, LOW = Disable.
D3	GNDA	G	Analog Ground pin
D4	RX_EN	DI	Enable control for LDO5 (RX). HIGH = Enable, LOW = Disable.
D5	LDO5	A	LDO5 Output (RX)

(1) A: Analog. D: Digital. I: Input. DI/O: Digital Input/Output. G: Ground. O: Output. P: Power.

PIN DESCRIPTION (continued)

Pin #	Name	Type ⁽¹⁾	Description
E1	LDO1	A	LDO1 Output (CORE)
E2	LDO2	A	LDO2 Output (DIGI)
E3	LDO3	A	LDO3 Output (ANA)
E4	LDO4	A	LDO4 Output (TCXO)
E5	VIN2	P	Battery Input for LDO3 - 7

Applications Schematic Diagram

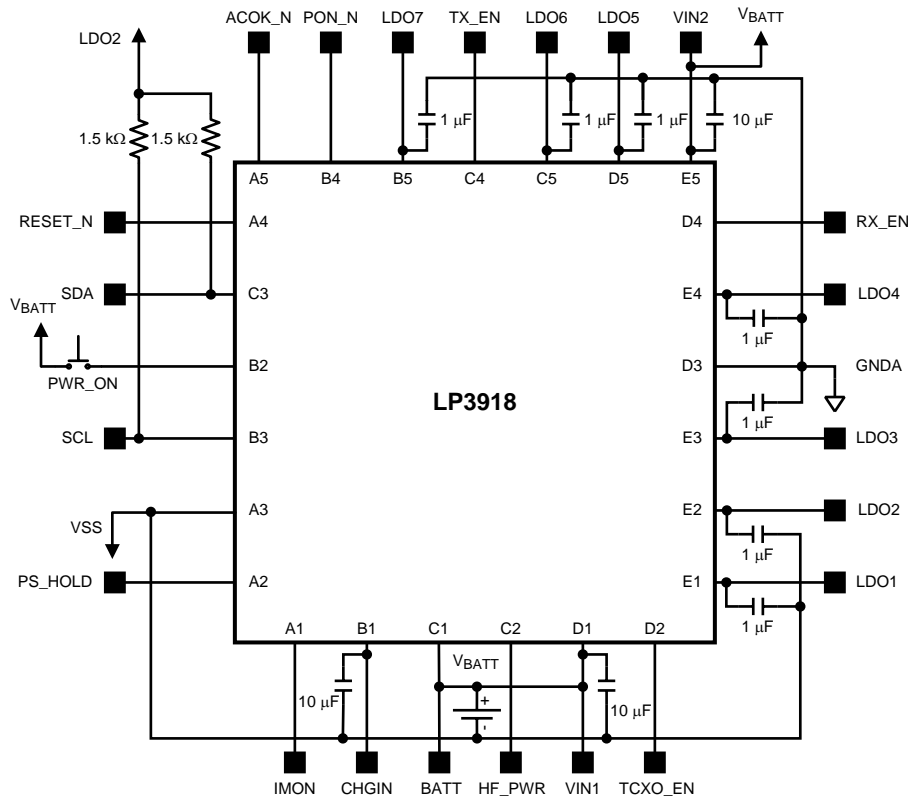

Figure 3. Applications Schematic

Device Description

The LP3918 Charge Management and Regulator Unit is designed to supply charger and voltage output capabilities for mobile systems, e.g. CDMA handsets. The device provides a Li-Ion charging function and 7 regulated outputs. Communication with the device is via an I2C compatible serial interface that allows function control and status read-back.

The battery charge management section provides a programmable CC/CV linear charge capability. Following a normal charge cycle a maintenance mode keeps battery voltage between programmable levels. Power levels are thermally regulated to obtain optimum charge levels over the ambient temperature range.

Charger Features

- Pre-charge, CC, CV and Maintenance modes
- USB Charge 100mA/450mA
- Integrated FET
- Integrated Reverse Current Blocking Diode
- Integrated Sense Resistor

- Thermal regulation
- Charge Current Monitor Output
- Programmable charge current 50mA - 950mA with 50mA steps
- Default CC mode current 100mA
- Pre-charge current fixed 50mA
- Termination voltage 4.1V, 4.2V (default), 4.3V, and 4.4V, accuracy better than +/- 0.5% (typ)
- Restart level 50mV, 100mV, 150mV (default) and 200mV below Termination voltage
- End of Charge 0.1C (default), 0.15C, 0.2C and 0.25C
- Programmable Enable Control
- Safety timer
- Input voltage operating range 4.5V - 6.0V
- LDO mode on LP3918TL-L option.

REGULATORS

7 Low dropout linear regulators provide programmable voltage outputs with current capabilities of 80mA, 150mA and 300mA as given in the table below. LDO1, LDO2 and LDO3 are powered up by default with LDO1 reaching regulation before LDO2 and LDO3 are started. LDO1, LDO3 and LDO7 can be disabled/enabled via the serial interface. During power up LDO1 and LDO2 must reach their regulation voltage detection point for the device to power up and remain powered. LDO4, LDO5 and LDO6 have external enable pins and may power up following LDO2 as determined by their respective enable. Under voltage lockout oversees device start up with preset level of 2.85V(typ).

POWER SUPPLY CONFIGURATIONS

At PMU start up, LDO1, LDO2 and LDO3 are always started with their default voltages. The start up sequence of the LDO's is given below.

Startup Sequence

LDO1 -> LDO2 -> LDO3

LDO's with external enable control (LDO4, LDO5, LDO6) start immediately after LDO2 if enabled by logic high at their respective control inputs.

LDO7 (and LDO1 and 3) may be programmed to enable/disable once PS_HOLD has been asserted.

Default voltages for the LDOs are shown in [Table 1](#) and [Table 2](#) shows the voltages that may be programmed via the Serial Interface.

DEVICE PROGRAMMABILITY

An I²C compatible Serial Interface is used to communicate with the device to program a series of registers and also to read status registers. These internal registers allow control over LDO outputs and their levels. The charger functions may also be programmed to alter termination voltage, end of charge current, charger restart voltage, full rate charge current, and also the charging mode.

This device internal logic is powered from LDO2.

Table 1. LDO Default Voltages

LDO	Function	mA	Default Voltage (V)	Startup Default	Enable Control
1	CORE	300	1.8	ON	SI
2	DIGI	300	3.0	ON	-
3	ANA	80	3.0	ON	SI
4	TCXO	80	3.0	OFF	TCXO_EN
5	RX	150	3.0	OFF	RX_EN
6	TX	150	3.0	OFF	TX_EN
7	GP	150	3.0	OFF	SI

Table 2. LDO Output Voltages Selectable via Serial Interface

LDO	mA	1.5	1.8	1.85	2.5	2.6	2.7	2.75	2.8	2.85	2.9	2.95	3.0	3.05	3.1	3.2	3.3
1 CORE	300	+	+	+	+	+	+	+	+	+	+	+	+	+	+	+	+
2 DIGI	300				+	+	+	+	+	+	+	+	+	+	+	+	+
3 ANA	80						+	+	+	+	+	+	+	+			
4 TCXO	80	+	+	+	+	+	+	+	+	+	+	+	+	+	+	+	+
5 RX	150						+	+	+	+	+	+	+	+			
6 TX	150						+	+	+	+	+	+	+	+			
7 GP	150	+	+	+	+	+	+	+	+	+	+	+	+	+	+	+	+



These devices have limited built-in ESD protection. The leads should be shorted together or the device placed in conductive foam during storage or handling to prevent electrostatic damage to the MOS gates.

Absolute Maximum Ratings ⁽¹⁾ ⁽²⁾ ⁽³⁾

CHG-IN,	-0.3 to +6.5V
VBATT =VIN1/2, BATT,HF_PWR	-0.3 to +6V
All other Inputs	-0.3 to V _{BATT} +0.3V, max 6.0V
Junction Temperature (T _{J-MAX})	150°C
Storage Temperature	-40°C to +150°C
Max Continuous Power Dissipation ⁽⁴⁾ (P _{D-MAX}) ⁽⁵⁾	Internally Limited
ESD ⁽⁶⁾	
Batt, VIN1, VIN2, HF_PWR, CHG_IN, PWR_ON	8kV HBM
All other pins	2kV HBM

- All voltages are with respect to the potential at the GND pin.
- Absolute Maximum Ratings are limits beyond which damage to the device may occur. Operating Ratings are conditions under which operation of the device is specified. Operating Ratings do not imply performance limits. For performance limits and associated test conditions, see the Electrical Characteristics tables.
- If Military/Aerospace specified devices are required, please contact the TI Sales Office/Distributors for availability and specifications.
- Care must be exercised where high power dissipation is likely. The maximum ambient temperature may have to be derated. Like the Absolute Maximum power dissipation, the maximum power dissipation for operation depends on the ambient temperature. In applications where high power dissipation and/or poor thermal dissipation exists, the maximum ambient temperature may have to be derated. Maximum ambient temperature (T_{A-MAX}) is dependent on the maximum power dissipation of the device in the application (P_{D-MAX}), and the junction to ambient thermal resistance of the device/package in the application (θ_{JA}), as given by the following equation: T_{A-MAX} = T_{J-MAX-OP} - (θ_{JA} X P_{D-MAX})
- Internal Thermal Shutdown circuitry protects the device from permanent damage.
- The human-body model is 100pF discharged through 1.5kΩ. The machine model is a 200pF capacitor discharged directly into each pin, MIL-STD-883 3015.7.

Operating Ratings ⁽¹⁾ ⁽²⁾

CHG_IN	4.5 to 6.0V
VBATT =VIN1/2, BATT	3.0 to 5.5V
HF_PWR, PWR_ON	0V to 5.5V
ACOK_N, SDA, SCL, RX_EN, TX_EN, TCXO_EN, PS_HOLD, RESET_N	0V to (V _{LDO2} + 0.3V)
All other pins	0V to (V _{BATT} + 0.3V)
Junction Temperature (T _J)	-40°C to +125°C
Ambient Temperature (T _A)	-40 to 85°C

- Absolute Maximum Ratings are limits beyond which damage to the device may occur. Operating Ratings are conditions under which operation of the device is specified. Operating Ratings do not imply performance limits. For performance limits and associated test conditions, see the Electrical Characteristics tables.
- All voltages are with respect to the potential at the GND pin.

Thermal Properties ⁽¹⁾

Junction to Ambient Thermal Resistance θ_{JA}	
Jedec Standard Thermal PCB	37°C/W
4L Cellphone Board	66°C/W

- (1) Junction-to-ambient thermal resistance (θ_{JA}) is taken from thermal modelling result, performed under the conditions and guidelines set forth in the JEDEC standard JESD51-7. The value of (θ_{JA}) of this product could fall within a wide range, depending on PWB material, layout, and environmental conditions. In applications where high maximum power dissipation exists (high V_{IN} , high I_{OUT}), special care must be paid to thermal dissipation issues in board design.

General Electrical Characteristics

Unless otherwise noted, V_{IN} (= V_{IN1} = V_{IN2} = $BATT$) = 3.6V, GND = 0V, C_{VIN1-2} = 10 μ F, C_{LDOX} = 1 μ F. Typical values and limits appearing in normal type apply for T_J = 25°C. Limits appearing in **boldface** type apply over the entire junction temperature range for operation, T_a = T_J = -40°C to +125°C. ⁽¹⁾

Symbol	Parameter	Condition	Typ	Limit		Units
				Min	Max	
$I_{Q(STANDBY)}$	Standby Supply Current	V_{IN} = 3.6V, UVLO on, internal logic circuit on, all other circuits off	2		10	μ A
Power Monitor Functions						
Battery Under-Voltage Lockout						
V_{UVLO-R}	Under Voltage Lock-out	V_{IN} Rising	2.85	2.7	3.0	V
Thermal Shutdown						
	TSD Threshold	(2)	160			°C
LOGIC AND CONTROL INPUTS (LDO2 at 3.0V)						
V_{IL}	Input Low Level	PS_HOLD, SDA, SCL, RX_EN, TCXO_EN, TX_EN			$0.25 \times V_{LDO2}$	V
		PWR_ON, HF_PWR			$0.25 \times V_{BATT}$	V
V_{IH}	Input High Level	PS_HOLD, SDA, SCL, RX_EN, TCXO_EN, TX_EN		$0.75 \times V_{LDO2}$		V
		PWR_ON, HF_PWR		$0.75 \times V_{BATT}$		V
I_{IL}	Logic Input Current	All logic inputs except PWR_ON and HF_PWR		-5	+5	μ A
		$0V \leq V_{INPUT} \leq V_{BATT}$				
R_{IN}	Input Resistance	PWR_ON, HF_PWR Pull-Down resistance to GND ⁽²⁾	500			k Ω
LOGIC AND CONTROL OUTPUTS (LDO2 at 3.0V)						
V_{OL}	Output Low Level	PON_N, RESET_N, SDA, ACOK_N			$0.25 \times V_{LDO2}$	V
		$I_{OUT} = 2mA$				
V_{OH}	Output High Level	PON_N, RESET_N, ACOK_N		$0.75 \times V_{LDO2}$		V
		$I_{OUT} = 2mA$				
		(Not applicable to Open Drain Output SDA)				

- (1) All electrical characteristics having room-temperature limits are tested during production with T_J = 25°C. All hot and cold limits are specified by correlating the electrical characteristics to process and temperature variations and applying statistical process control.
- (2) Specified by design. Not production tested.

LDO1 (CORE) Electrical Characteristics

Unless otherwise noted, V_{IN} ($= V_{IN1} = V_{IN2} = BATT$) = 3.6V, $GND = 0V$, $C_{VIN1-2} = 10\mu F$, $C_{LDOX} = 1\mu F$. V_{OUT1} set to 3.0V output. Note V_{INMIN} is the greater of 3.0V or $V_{OUT1} + 0.5V$. Typical values and limits appearing in normal type apply for $T_J = 25^\circ C$. Limits appearing in **boldface** type apply over the entire junction temperature range for operation, $T_a = T_J = -40^\circ C$ to $+125^\circ C$.⁽¹⁾

Symbol	Parameter	Condition	Typ	Limit		Units
				Min	Max	
V_{OUT1}	Output Voltage Accuracy	$I_{OUT1} = 1mA$, $V_{OUT1} = 3.0V$		-2	+2	%
	Output Voltage	Default	1.8	-3	+3	V
I_{OUT1}	Output Current	$V_{INMIN} \leq V_{IN} \leq 5.5V$			300	mA
	Output Current Limit	$V_{OUT1} = 0V$	600			
V_{DO1}	Dropout Voltage	$I_{OUT1} = 300mA$, ⁽²⁾	200		280	mV
ΔV_{OUT1}	Line Regulation	$V_{INMIN} \leq V_{IN} \leq 5.5V$ $I_{OUT1} = 1mA$	2			mV
	Load Regulation	$1mA \leq I_{OUT1} \leq 300mA$	20			mV
e_{n1}	Output Noise Voltage	$10Hz \leq f \leq 100KHz$, $C_{OUT} = 1\mu F$ ⁽³⁾	45			μV_{RMS}
PSRR	Power Supply Rejection Ratio	$F = 10kHz$, $C_{OUT} = 1\mu F$ $I_{OUT1} = 20mA$ ⁽³⁾	65			dB
$t_{START-UP}$	Start-Up Time from Shut-down	$C_{OUT} = 1\mu F$, $I_{OUT1} = 300mA$ ⁽³⁾	60		170	μs
$T_{Transient}$	Start-Up Transient Overshoot	$C_{OUT} = 1\mu F$, $I_{OUT1} = 300mA$ ⁽³⁾	60		120	mV

- (1) All electrical characteristics having room-temperature limits are tested during production with $T_J = 25^\circ C$. All hot and cold limits are specified by correlating the electrical characteristics to process and temperature variations and applying statistical process control.
- (2) Dropout voltage is the input-to-output voltage difference at which the output voltage is 100mV below its nominal value. This specification does not apply in cases it implies operation with an input voltage below the 3.0V minimum appearing under Operating Ratings. For example, this specification does not apply for devices having 1.5V outputs because the specification would imply operation with an input voltage at or about 1.5V.
- (3) Specified by design. Not production tested.

LDO2 (DIGI) Electrical Characteristics

Unless otherwise noted, V_{IN} ($= V_{IN1} = V_{IN2} = BATT$) = 3.6V, $GND = 0V$, $C_{VIN1-2} = 10\mu F$, $C_{LDOX} = 1\mu F$. Note V_{INMIN} is the greater of 3.0V or $V_{OUT2} + 0.5V$. Typical values and limits appearing in normal type apply for $T_J = 25^\circ C$. Limits appearing in **boldface** type apply over the entire junction temperature range for operation, $T_a = T_J = -40^\circ C$ to $+125^\circ C$.⁽¹⁾

Symbol	Parameter	Condition	Typ	Limit		Units
				Min	Max	
V_{OUT2}	Output Voltage Accuracy	$I_{OUT2} = 1mA$, $V_{OUT2} = 3.0V$		-2	+2	%
	Output Voltage	Default	3.0	-3	+3	V
I_{OUT2}	Output Current	$V_{INMIN} \leq V_{IN} \leq 5.5V$			300	mA
	Output Current Limit	$V_{OUT2} = 0V$	600			
V_{DO2}	Dropout Voltage	$I_{OUT2} = 300mA$ ⁽²⁾	200		280	mV
ΔV_{OUT2}	Line Regulation	$V_{INMIN} \leq V_{IN} \leq 5.5V$ $I_{OUT2} = 1mA$	2			mV
	Load Regulation	$1mA \leq I_{OUT2} \leq 300mA$	20			mV

- (1) All electrical characteristics having room-temperature limits are tested during production with $T_J = 25^\circ C$. All hot and cold limits are specified by correlating the electrical characteristics to process and temperature variations and applying statistical process control.
- (2) Dropout voltage is the input-to-output voltage difference at which the output voltage is 100mV below its nominal value. This specification does not apply in cases it implies operation with an input voltage below the 3.0V minimum appearing under Operating Ratings. For example, this specification does not apply for devices having 1.5V outputs because the specification would imply operation with an input voltage at or about 1.5V.

LDO2 (DIGI) Electrical Characteristics (continued)

Unless otherwise noted, V_{IN} (= $V_{IN1} = V_{IN2} = BATT$) = 3.6V, $GND = 0V$, $C_{VIN1-2} = 10\mu F$, $C_{LDOX} = 1\mu F$. Note V_{INMIN} is the greater of 3.0V or $V_{OUT2} + 0.5V$. Typical values and limits appearing in normal type apply for $T_J = 25^\circ C$. Limits appearing in **boldface** type apply over the entire junction temperature range for operation, $T_a = T_J = -40^\circ C$ to $+125^\circ C$.⁽¹⁾

Symbol	Parameter	Condition	Typ	Limit		Units
				Min	Max	
e_{n2}	Output Noise Voltage	10Hz ≤ f ≤ 100KHz,	45			μV_{RMS}
		$C_{OUT} = 1\mu F$ ⁽³⁾				
PSRR	Power Supply Rejection Ratio	F = 10kHz, $C_{OUT} = 1\mu F$	65			dB
		$I_{OUT2} = 20mA$ ⁽³⁾				
$t_{START-UP}$	Start-Up Time from Shut-down	$C_{OUT} = 1\mu F$, $I_{OUT2} = 300mA$ (3)	40		60	μs
$t_{Transient}$	Start-Up Transient Overshoot	$C_{OUT} = 1\mu F$, $I_{OUT2} = 300mA$ (3)	5		30	mV

(3) Specified by design. Not production tested.

LDO3 (ANA), LDO4 (TCXO) Electrical Characteristics

Unless otherwise noted, V_{IN} (= $V_{IN1} = V_{IN2} = BATT$) = 3.6V, $GND = 0V$, $C_{VIN1-2} = 10\mu F$, $C_{LDOX} = 1\mu F$. TCXO_EN high. Note V_{INMIN} is the greater of 3.0V or $V_{OUT3/4} + 0.5V$. Typical values and limits appearing in normal type apply for $T_J = 25^\circ C$. Limits appearing in **boldface** type apply over the entire junction temperature range for operation, $T_a = T_J = -40^\circ C$ to $+125^\circ C$.⁽¹⁾

Symbol	Parameter	Condition	Typ	Limit		Units
				Min	Max	
V_{OUT3}, V_{OUT4}	Output Voltage Accuracy	$I_{OUT3/4} = 1mA$, $V_{OUT3/4} = 3.0V$		-2	+2	%
	Output Voltage	LDO3 default	3.0			V
		LDO4 default	3.0			
I_{OUT3}, I_{OUT4}	Output Current	$V_{INMIN} \leq V_{IN} \leq 5.5V$			80	mA
	Output Current Limit	$V_{OUT3/4} = 0V$	160			
V_{DO3}, V_{DO4}	Dropout Voltage	$I_{OUT3/4} = 80mA$ ⁽²⁾	180		220	mV
$\Delta V_{OUT3}, \Delta V_{OUT4}$	Line Regulation	$V_{INMIN} \leq V_{IN} \leq 5.5V$	2			mV
		$I_{OUT3/4} = 1mA$				
	Load Regulation	$1mA \leq I_{OUT3/4} \leq 80mA$	20			mV
e_{n3}, e_{n4}	Output Noise Voltage	10Hz ≤ f ≤ 100kHz,	45			μV_{RMS}
		$C_{OUT} = 1\mu F$ ⁽³⁾				
PSRR	Power Supply Rejection Ratio	F = 10kHz, $C_{OUT} = 1\mu F$	65			dB
		$I_{OUT3/4} = 20mA$ ⁽³⁾				
$t_{START-UP}$	Start-Up Time from Shut-down	$C_{OUT} = 1\mu F$, $I_{OUT3/4} = 80mA$ (3)	40		60	μs
$t_{Transient}$	Start-Up Transient Overshoot	$C_{OUT} = 1\mu F$, $I_{OUT3/4} = 80mA$ (3)	5		30	mV

- (1) All electrical characteristics having room-temperature limits are tested during production with $T_J = 25^\circ C$. All hot and cold limits are specified by correlating the electrical characteristics to process and temperature variations and applying statistical process control.
- (2) Dropout voltage is the input-to-output voltage difference at which the output voltage is 100mV below its nominal value. This specification does not apply in cases it implies operation with an input voltage below the 3.0V minimum appearing under Operating Ratings. For example, this specification does not apply for devices having 1.5V outputs because the specification would imply operation with an input voltage at or about 1.5V.
- (3) Specified by design. Not production tested.

LDO5 (RX), LDO6 (TX), LDO7 (GP) Electrical Characteristics

Unless otherwise noted, V_{IN} (= $V_{IN1} = V_{IN2} = BATT$) = 3.6V, $GND = 0V$, $C_{VIN1-2} = 10\mu F$, $C_{LDOX} = 1\mu F$. RX_EN, TX_EN high. LDO7 Enabled via Serial Interface. Note V_{INMIN} is the greater of 3.0V or $V_{OUT5/6/7} + 0.5V$. Typical values and limits appearing in normal type apply for $T_J = 25^\circ C$. Limits appearing in **boldface** type apply over the entire junction temperature range for

LDO5 (RX), LDO6 (TX), LDO7 (GP) Electrical Characteristics (continued)

Unless otherwise noted, V_{IN} (= V_{IN1} = V_{IN2} = BATT) = 3.6V, GND = 0V, C_{VIN1-2} = 10 μ F, C_{LDOX} = 1 μ F. RX_EN, TX_EN high. LDO7 Enabled via Serial Interface. Note V_{INMIN} is the greater of 3.0V or $V_{OUT5/6/7} + 0.5$ V. Typical values and limits appearing in normal type apply for $T_J = 25^\circ\text{C}$. Limits appearing in **boldface** type apply over the entire junction temperature range for operation, $T_a = T_J = -40^\circ\text{C}$ to $+125^\circ\text{C}$. ⁽¹⁾

operation, $T_a = T_J = -40^\circ\text{C}$ to $+125^\circ\text{C}$. ⁽¹⁾

Symbol	Parameter	Condition	Typ	Limit		Units
				Min	Max	
$V_{OUT5}, V_{OUT6}, V_{OUT7}$	Output Voltage	$I_{OUT5/6/7} = 1\text{mA}, V_{OUT5/6/7} = 3.0\text{V}$		-2	+2	%
	Output Voltage	LDO5 default	3.0			V
		LDO6 default	3.0			
		LDO7 default	3.0			
$I_{OUT5}, I_{OUT6}, I_{OUT7}$	Output Current	$V_{INMIN} \leq V_{IN} \leq 5.5\text{V}$			150	mA
	Output Current Limit	$V_{OUT5/6/7} = 0\text{V}$	300			
$V_{DO5}, V_{DO6}, V_{DO7}$	Dropout Voltage	$I_{OUT5/6/7} = 150\text{mA}$ ⁽²⁾	180		240	mV
$\Delta V_{OUT5}, \Delta V_{OUT6}, \Delta V_{OUT7}$	Line Regulation	$V_{INMIN} \leq V_{IN} \leq 5.5\text{V}$ $I_{OUT5/6/7} = 1\text{mA}$	2			mV
	Load Regulation	$1\text{mA} \leq I_{OUT5/6/7} \leq 150\text{mA}$	20			mV
e_{n5}, e_{n6}, e_{n7}	Output Noise Voltage	$10\text{Hz} \leq f \leq 100\text{kHz},$ $C_{OUT} = 1\mu\text{F}$ ⁽³⁾	45			μV_{RMS}
PSRR	Power Supply Rejection Ratio	$F = 10\text{kHz}, C_{OUT} = 1\mu\text{F}$ $I_{OUT5/6/7} = 20\text{mA}$ ⁽³⁾	65			dB
$t_{\text{START-UP}}$	Start-Up Time from Shut-down	$C_{OUT} = 1\mu\text{F}, I_{OUT5/6/7} = 150\text{mA}$ ⁽³⁾	40		60	μs
$t_{\text{Transient}}$	Start-Up Transient Overshoot	$C_{OUT} = 1\mu\text{F}, I_{OUT5/6/7} = 150\text{mA}$ ⁽³⁾	5		30	mV

- (1) All electrical characteristics having room-temperature limits are tested during production with $T_J = 25^\circ\text{C}$. All hot and cold limits are specified by correlating the electrical characteristics to process and temperature variations and applying statistical process control.
- (2) Dropout voltage is the input-to-output voltage difference at which the output voltage is 100mV below its nominal value. This specification does not apply in cases it implies operation with an input voltage below the 3.0V minimum appearing under Operating Ratings. For example, this specification does not apply for devices having 1.5V outputs because the specification would imply operation with an input voltage at or about 1.5V.
- (3) Specified by design. Not production tested.

Charger Electrical Characteristics

Unless otherwise noted, $V_{CHG_IN} = 5V$, V_{IN} (= $V_{IN1} = V_{IN2} = BATT$) = 3.6V. $C_{CHG_IN} = 10\mu F$, $C_{BATT} = 30\mu F$. Charger set to default settings unless otherwise noted. Typical values and limits appearing in normal type apply for $T_J = 25^\circ C$. Limits appearing in **boldface** type apply over the entire junction temperature range for operation, $T_a = T_J = -25^\circ C$ to $+85^\circ C$. ⁽¹⁾⁽²⁾

Symbol	Parameter	Condition	Typ	Limit		Units
				Min	Max	
V_{CHG_IN}	Input Voltage Range			4.5	6.5	V
	Operating Range			4.5	6	
V_{OK_CHG}	CHG_IN OK trip-point	$V_{CHG_IN} - V_{BATT}$ (Rising)	200			mV
		$V_{CHG_IN} - V_{BATT}$ (Falling)	50			
V_{TERM}	Battery Charge Termination voltage	Default	4.2			V
	V_{TERM} voltage tolerance	$T_J = 25^\circ C$		-0.35	+0.35	%
		$T_J = 0^\circ C$ to $85^\circ C$		-1	+1	
I_{CHG}	Fast Charge Current Accuracy	$I_{CHG} = 450mA$		-10	+10	%
	Programmable full-rate charge current range (default 100mA)	$6.0V \geq V_{CHG_IN} \geq 4.5V$		50	950	mA
		$V_{BATT} < (V_{CHG_IN} - V_{OK_CHG})$				
		$V_{FULL_RATE} < V_{BATT} < V_{TERM}$ (3)				
Default		100				
	Charge current programming step		50			
$I_{PREQUAL}$	Pre-qualification current	$V_{BATT} = 2V$	50	40	60	mA
I_{CHG_USB}	CHG_IN programmable current in USB mode	$5.5V \geq V_{CHG_IN} \geq 4.5V$	Low	100		mA
		$V_{BATT} < (V_{CHG_IN} - V_{OK_CHG})$				
		$V_{FULL_RATE} < V_{BATT} < V_{TERM}$	High	450		
		Default = 100mA		100		
V_{FULL_RATE}	Full-rate qualification threshold	V_{BATT} rising, transition from pre-qual to full-rate charging	3.0	2.9	3.1	V
I_{EOC}	End of Charge Current, % of full-rate current	0.1C option selected	10			%
$V_{RESTART}$	Restart threshold voltage	V_{BATT} falling, transition from EOC to full-rate charge mode. Default options selected - 4.05V	4.05	3.97	4.13	V
I_{MON}	I_{MON} Voltage 1	$I_{CHG} = 100mA$	0.247			V
	I_{MON} Voltage 2	$I_{CHG} = 450mA$	1.112	0.947	1.277	
T_{REG}	Regulated junction temperature	⁽⁴⁾	115			$^\circ C$

- (1) All electrical characteristics having room-temperature limits are tested during production with $T_J = 25^\circ C$. All hot and cold limits are specified by correlating the electrical characteristics to process and temperature variations and applying statistical process control.
- (2) Junction-to-ambient thermal resistance (θ_{JA}) is taken from thermal modelling result, performed under the conditions and guidelines set forth in the JEDEC standard JESD51-7. The value of (θ_{JA}) of this product could fall within a wide range, depending on PWB material, layout, and environmental conditions. In applications where high maximum power dissipation exists (high V_{IN} , high I_{OUT}), special care must be paid to thermal dissipation issues in board design.
- (3) Full charge current is specified for $CHG_IN = 4.5$ to $6.0V$. At higher input voltages, increased power dissipation may cause the thermal regulation to limit the current to a safe level, resulting in longer charging time.
- (4) Specified by design. Not production tested.

Charger Electrical Characteristics (continued)

Unless otherwise noted, $V_{\text{CHG-IN}} = 5\text{V}$, $V_{\text{IN}} (= \text{VIN1} = \text{VIN2} = \text{BATT}) = 3.6\text{V}$. $C_{\text{CHG-IN}} = 10\mu\text{F}$, $C_{\text{BATT}} = 30\mu\text{F}$. Charger set to default settings unless otherwise noted. Typical values and limits appearing in normal type apply for $T_J = 25^\circ\text{C}$. Limits appearing in **boldface** type apply over the entire junction temperature range for operation, $T_a = T_J = -25^\circ\text{C}$ to $+85^\circ\text{C}$. ⁽¹⁾⁽²⁾

Symbol	Parameter	Condition	Typ	Limit		Units
				Min	Max	
Detection and Timing ⁽⁵⁾						
T_{POK}	Power OK deglitch time	$V_{\text{BATT}} < (V_{\text{CC}} - V_{\text{OK_CHG}})$	32			mS
$T_{\text{PQ_FULL}}$	Deglitch time	Pre-qualification to full-rate charge transition	230			mS
T_{CHG}	Charge timer	Precharge mode	1			Hrs
		Full Rate Charging Timeout	5			
		Constant Voltage Timeout	5			
T_{EOC}	Deglitch time for end-of-charge transition		230			mS

(5) Specified by design. Not production tested.

Serial Interface

Unless otherwise noted, V_{IN} (= VIN1 = VIN2 = BATT) = 3.6V, GND = 0V, C_{VIN1-2} = 10 μ F, C_{LDOX} = 1 μ F, and V_{LDO2} (DIG) = 3.0V. Typical values and limits appearing in normal type apply for $T_J = 25^\circ\text{C}$. Limits appearing in **boldface** type apply over the entire junction temperature range for operation, $T_a = T_J = -40^\circ\text{C}$ to $+125^\circ\text{C}$. ⁽¹⁾⁽²⁾

Symbol	Parameter	Condition	Typ	Limit		Units
				Min	Max	
f_{CLK}	Clock Frequency				400	kHz
t_{BF}	Bus-Free Time between START and STOP			1.3		μ s
t_{HOLD}	Hold Time Repeated START Condition			0.6		μ s
t_{CLK-LP}	CLK Low Period			1.3		μ s
t_{CLK-HP}	CLK High Period			0.6		μ s
t_{SU}	Set-Up Time Repeated START Condition			0.6		μ s
$t_{DATA-HOLD}$	Data Hold Time			50		ns
$t_{DATA-SU}$	Data Set-Up Time			100		ns
t_{SU}	Set-Up Time for STOP Condition			0.6		μ s
t_{TRANS}	Maximum Pulse Width of Spikes that Must be Suppressed by the Input Filter of both DATA & CLK Signals		50			ns

- (1) All electrical characteristics having room-temperature limits are tested during production with $T_J = 25^\circ\text{C}$. All hot and cold limits are specified by correlating the electrical characteristics to process and temperature variations and applying statistical process control.
- (2) Specified by design. Not production tested.

REGISTER INFORMATION, SLAVE ADDRESS CODE 7H'7E

Table 3. Control Registers⁽¹⁾⁽²⁾

Addr	Register (default value)	D7	D6	D5	D4	D3	D2	D1	D0
8h'00	OP_EN (0000 0101)	X	X	X	X	LDO7_EN	LDO3_EN	X	LDO1_EN
8h'01	LDO1PGM O/P (0000 0001)	X	X	X	X	V1_OP[3]	V1_OP[2]	V1_OP[1]	V1_OP[0]
8h'02	LDO2PGM O/P (0000 1011)	X	X	X	X	V2_OP[3]	V2_OP[2]	V2_OP[1]	V2_OP[0]
8h'03	LDO3PGM O/P (0000 1011)	X	X	X	X	V3_OP[3]	V3_OP[2]	V3_OP[1]	V3_OP[0]
8h'04	LDO4PGM O/P (0000 1011)	X	X	X	X	V4_OP[3]	V4_OP[2]	V4_OP[1]	V4_OP[0]
8h'05	LDO5PGM O/P (0000 1011)	X	X	X	X	V5_OP[3]	V5_OP[2]	V5_OP[1]	V5_OP[0]
8h'06	LDO6PGM O/P (0000 1011)	X	X	X	X	V6_OP[3]	V6_OP[2]	V6_OP[1]	V6_OP[0]
8h'07	LDO7PGM O/P (0000 1011)	X	X	X	X	V7_OP[3]	V7_OP[2]	V7_OP[1]	V7_OP[0]
8h'0C	STATUS (0000 0000)	PWR_ON _TRIG	HF_PWR _TRIG	CHG_IN _TRIG	X	X	X	X	X
8h'10	CHGCNTL1 (0000 1001)	USBMODE _EN	CHGMODE _EN	Force EOC	TOUT_ doubling	EN_Tout	En_EOC	X	EN_CHG
8h'11	CHGCNTL2 (0000 0001)				Prog_ ICHG[4]	Prog_ ICHG[3]	Prog_ ICHG[2]	Prog_ ICHG[1]	Prog_ ICHG[0]
8h'12	CHGCNTL3 (0001 0010)			VTERM[1]	VTERM[0]	Prog_ EOC[1]	Prog_ EOC[0]	Prog_ VRSTR[1]	Prog_ VRSTR[0]
8h'13	CHGSTATU S1	Batt_Over _Out	CHGIN_ OK_Out	EOC	Tout_ Fullrate	Tout_ Prechg	LDO Mode	Fullrate	PRECHG
8h'14	CHGSTATU S2							Tout_ ConstV	Bad_Batt
8h'1C	MISC Control1							APU_TSD_ EN	PS_HOLD _DELAY

- (1) X = Not Used
(R/O) = Bits are Read Only type.
Codes other than those shown in the table are disallowed.
- (2) Note that for Serial Interface operation and thus register control, LDO2 must be active to provide the power for the internal logic.

LDO Output Voltage Programming

The following table summarizes the supported output voltages for the LP3918. Default voltages after startup are highlighted in **bold**.

Data Code (Reg 01 - 07)	LDO1 V	LDO2 V	VLDO3 V	LDO4 V	LDO5 V	LDO6 V	LDO7 V
8h'00	1.5			1.5			1.5
8h'01	1.8			1.8			1.8
8h'02	1.85			1.85			1.85
8h'03	2.5	2.5		2.5			2.5
8h'04	2.6	2.6		2.6			2.6

8h'05	2.7	2.7	2.7	2.7	2.7	2.7	2.7
8h'06	2.75	2.75	2.75	2.75	2.75	2.75	2.75
8h'07	2.8	2.8	2.8	2.8	2.8	2.8	2.8
8h'08	2.85	2.85	2.85	2.85	2.85	2.85	2.85
8h'09	2.9	2.9	2.9	2.9	2.9	2.9	2.9
8h'0A	2.95	2.95	2.95	2.95	2.95	2.95	2.95
8h'0B	3.0	3.0	3.0	3.0	3.0	3.0	3.0
8h'0C	3.05	3.05	3.05	3.05	3.05	3.05	3.05
8h'0D	3.1	3.1		3.1			3.1
8h'0E	3.2	3.2		3.2			3.2
8h'0F	3.3	3.3		3.3			3.3

Charger Control Register 2

Note that Bits 7,6,5 are not used and must be set to 0 during write to this register.

CHARGER CURRENT PROGRAMMING

The following table summarizes the supported charging current values for the LP3918.

Default charge current after startup is highlighted in **bold**

Table 4. LP3918 Charger Current Programming

Address	Register ID	Current Selection Prog_ICHG<4..0> Bit 0 to Bit 4						
8h'11	CHGCNTL2	00000	00001	00010	00011	00100	00101	00110
		50mA	100mA	150mA	200mA	250mA	300mA	350mA
Address	Register ID	Current Selection Prog_ICHG<4..0> Bit 0 to Bit 4						
8h'11	CHGCNTL2	00111	01000	01001	01010	01011	01100	01101
		400mA	450mA	500mA	550mA	600mA	650mA	700mA
Address	Register ID	Current Selection Prog_ICHG<4..0> Bit 0 to Bit 4						
8h'11	CHGCNTL2	01110	01111	10000	10001	10010		
		750mA	800mA	850mA	900mA	950mA		

Charger Control Register 3

CHARGER TERMINATION VOLTAGE PROGRAMMING

Table 5. LP3918 Charger Termination Voltage Control

Address	Register ID	V _{TERM} Selection Bits		
		VTERM[1]	VTERM[0]	Termination Voltage(V)
8h'12	CHGCNTL3	CHGCNTL3<5>	CHGCNTL3<4>	
		0	0	4.1
		0	1	4.2 (Default)
		1	0	4.3
		1	1	4.4

END OF CHARGE CURRENT PROGRAMMING**Table 6. LP3918 EOC Current Control**

Address	Register ID	End Of Charge Current Selection Bits		
		PROG_EOC[1]	PROG_EOC[0]	End Of Charge Current
8h'12	CHGCNTL3	CHGCNTL3<3>	CHGCNTL3<2>	
		0	0	0.1 (Default)
		0	1	0.15C
		1	0	0.2C
		1	1	0.25C

CHARGING RESTART VOLTAGE PROGRAMMING**Table 7. LP3918 Charging Restart Voltage**

Address	Register ID	Charging Restart Voltage Selection Bits		
		PROG_VRSTR[1]	PROG_VRSTR[1]	Restart Voltage(V)
8h'12	CHGCNTL3	CHGCNTL3<1>	CHGCNTL3<0>	
		0	0	$V_{TERM} - 50mV$
		0	1	$V_{TERM} - 100mV$
		1	0	$V_{TERM} - 150mV$
		1	1	$V_{TERM} - 200mV$

Charger Control Register 1**CHARGING MODE SELECTION**

Charging mode selection changes will only take place when the battery voltage is above the 3.0V pre-charge/Full-rate charge threshold.

Table 8. LP3918 USB Charging Selection

Address	Register ID	USB Charge Mode Control Bits			Current
		USB_Mode_En	CHG_Mode_En	Mode	
8h'10	CHGCNTL1	CHGCNTL1<7>	CHGCNTL1<6>		
		0	0	Fast Charge	Default or Selection
		1	0	Fast Charge	Default or Selection
		0	1	USB	100mA
		1	1	USB	450mA

Device Power Up and Shutdown Timing

Figure 4. Device Power Up Logic Timing. PWR_ON

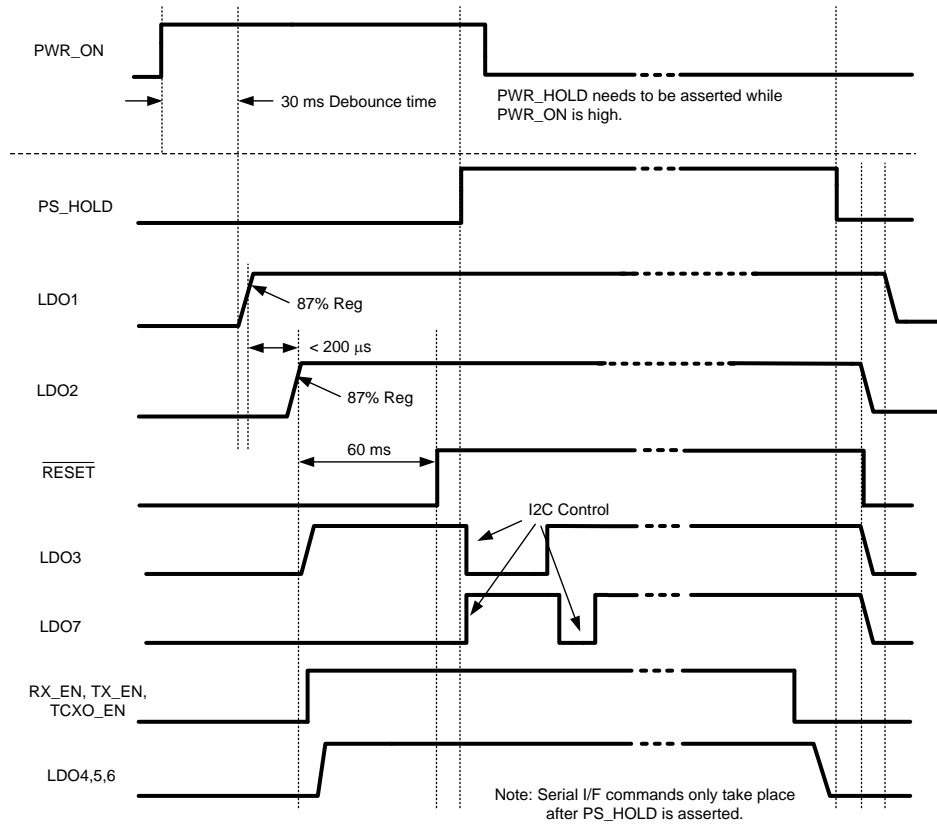

Figure 5. Device Power Up Logic Timing. CHG_IN, HF_PWR

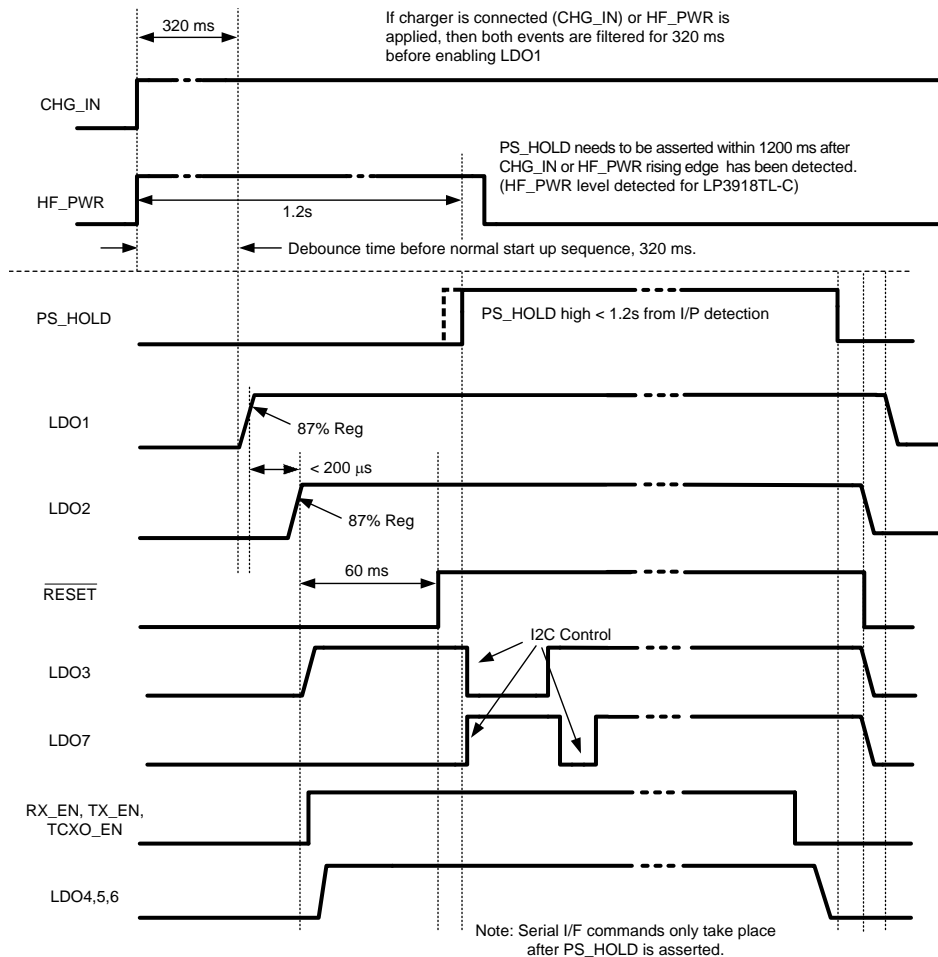

Figure 6. LP3918 Power On Behaviour (Failed PS_Hold)

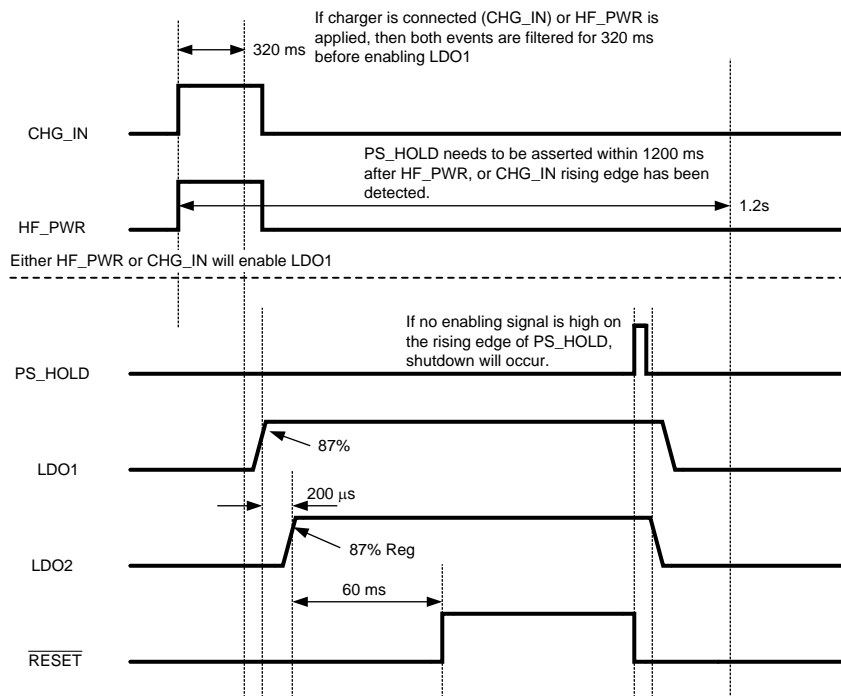
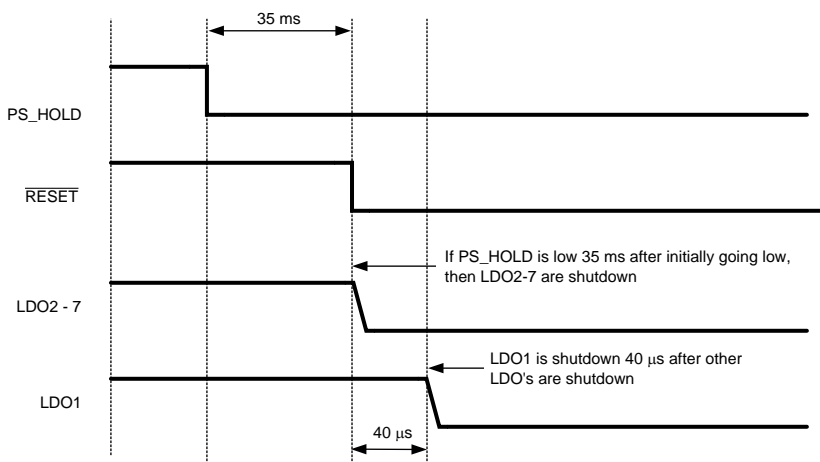

Figure 7. LP3918 Normal Shutdown Behaviour



Functional Block Diagram

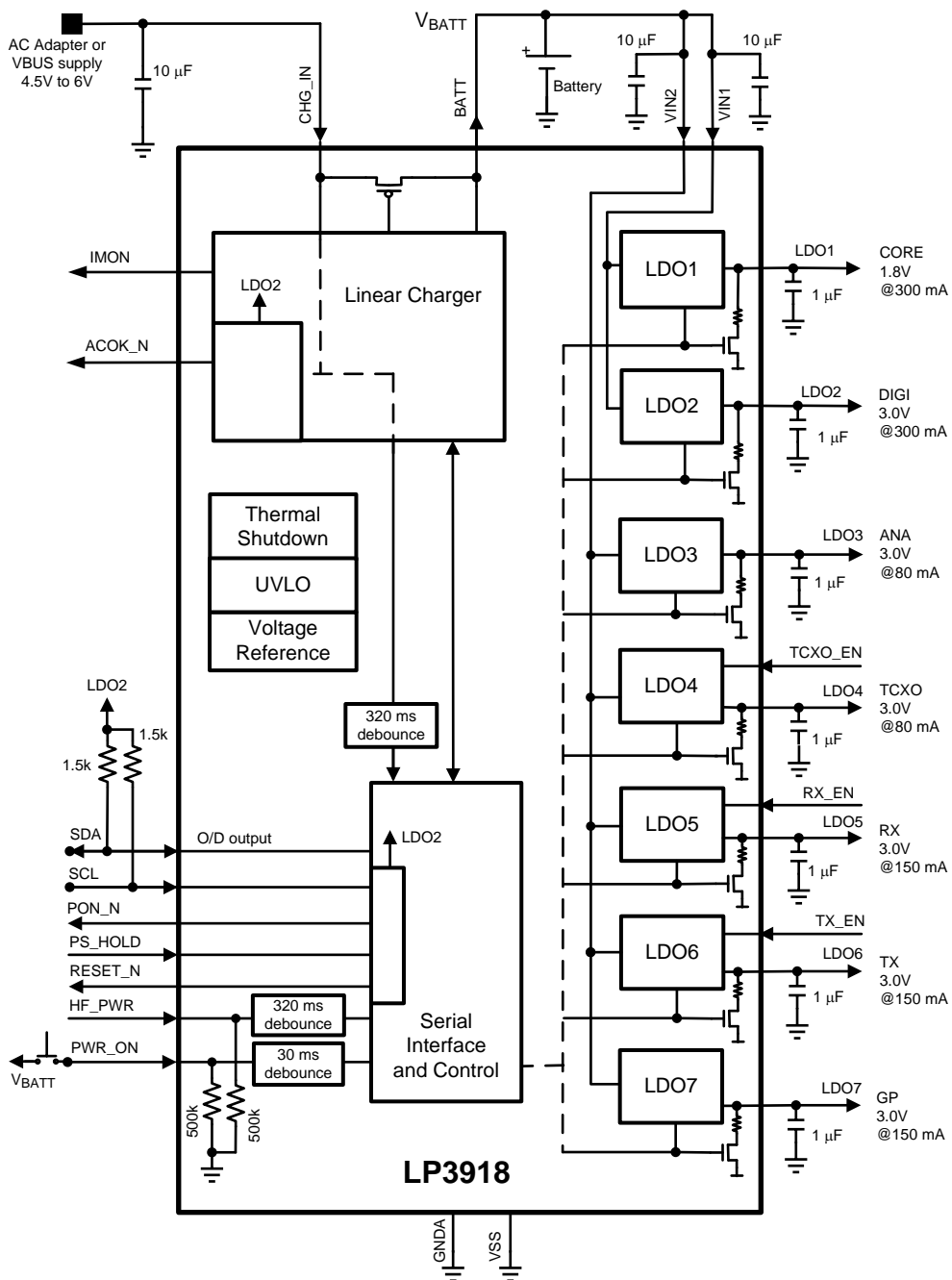

Figure 8. LP3918 Functional Block Diagram

TECHNICAL DESCRIPTION

BATTERY CHARGE MANAGEMENT

A charge management system allowing the safe charge and maintenance of a Li-Ion battery is implemented on the LP3918. This has a CC/CV linear charge capability with programmable battery regulation voltage and end of charge current threshold. The charge current in the constant current mode is programmable and a maintenance mode monitors for battery voltage drop to restart charging at a preset level. A USB charging mode is also available with 2 charge current levels.

CHARGER FUNCTION

Following the correct detection of an input voltage at the charger pin the charger enters a pre-charge mode. In this mode a constant current of 50mA is available to charge the battery to 3.0V. At this voltage level the charge management applies the default (100mA) full rate constant current to raise the battery voltage to the termination voltage level (default 4.2V). The full rate charge current may be programmed to a different level at this stage. When termination voltage (V_{TERM}) is reached, the charger is in constant voltage mode and a constant voltage of 4.2V is maintained. This mode is complete when the end of charge current (default 0.1C) is detected and the charge management enters the maintenance mode. In maintenance mode the battery voltage is monitored for the restart level (4.05V at the default settings) and the charge cycle is re-initiated to re-establish the termination voltage level.

For start up the EOC function is disabled. This function should be enabled once start up is complete and a battery has been detected. EOC is enabled via register CHGCNTL1, [Table 9](#).

The full rate constant current rate of charge may be programmed to 19 levels from 50mA to 950mA. These values are given in [Table 4](#), and [Table 11](#)

The charge mode may be programmed to USB mode when the charger input is applied and the battery voltage is above 3.0V. This provides two programmable current levels of 100mA and 450mA for a USB sourced supply input at CHG_IN. [Table 8](#)

LDO Mode on device option LP3918TL-L

The charger circuit automatically enters an LDO mode if no battery is detected on insertion of the charger input voltage. In LDO mode the battery pin is regulated to 4.2V and can source up to 1.0A of current. Normal operation with a battery connected can be re-established via the serial interface. The serial interface allows the device to switch between modes as required however care is required to ensure that LDO mode is not initiated while a battery is present.

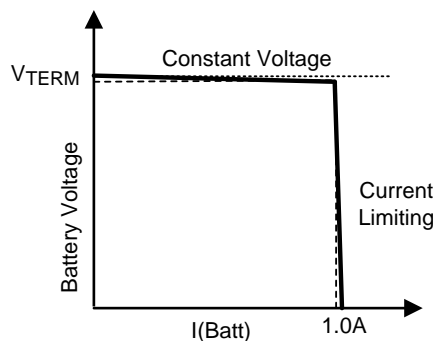

Figure 9. LDO Mode Diagram

EOC

EOC is disabled by default and should be enabled when the system processor is awake and the system detects that a battery is present.

Programming Information

Table 9. Register Address 8h'10: CHGCNTL1

BIT	NAME	FUNCTION
2	En_EOC	Enables the End Of Charge current level threshold detection. When set to '0' the EOC is disabled.

The **End Of Charge** current threshold default setting is at 0.1C. This EOC value is set relative to C the set full rate constant current. This threshold can be set to 0.1C, 0.15C, 0.2C or 0.25C by changing the contents of the PROG_EOC[1:0] register bits.

Table 10. Register Address 8h'12: CHGCNTL3

BIT	NAME	FUNCTION
2	Prog_EOC[0]	Set the End Of Charge Current. See Table 8
3	Prog_EOC[1]	

CHARGER FULL RATE CURRENT

Programming Information

Table 11. Register Address 8h'11: CHGCNTL2

Data BITS	HEX	NAME	FUNCTION
000[00000]	00	Prog_ICHG	50mA
000[00001]	01		100mA
000[00010]	02		150mA
000[00011]	03		200mA
000[00100]	04		250mA
000[00101]	05		300mA
000[00110]	06		350mA
000[00111]	07		400mA
000[01000]	08		450mA
000[01001]	09		500mA
000[01010]	0A		550mA
000[01011]	0B		600mA
000[01100]	0C		650mA
000[01101]	0D		700mA
000[01110]	0E		750mA
000[01111]	0F		800mA
000[10000]	10	850mA	
000[10001]	11	900mA	
000[10010]	12	950mA	

TERMINATION AND RESTART

The termination and restart voltage levels are determined by the data in the VTERM[1:0] and PROG_VSTRT[1:0] bits in the control register. The restart voltage is programmed relative to the selected termination voltage.

The Termination voltages available are 4.1V, 4.2V (default), 4.3V, and 4.4V.

The Restart voltages are determined relative to the termination voltage level and may be set to 50mV, 100mV, 150mV (default), and 200mV below the set termination voltage level.

Programming Information

Table 12. Register Address 8h'12: CHGCNTL3

BIT	NAME	FUNCTION
4	VTERM[0]	Set the charging termination voltage. See Table 5
5	VTERM[1]	

Table 13. Register Address 8h'12: CHGCNTL3

BIT	NAME	FUNCTION
0	VRSTRT[0]	Set the charging restart voltage. See Table 7
1	VRSTRT[1]	

Charger Operation

The operation of the charger with EOC enabled is shown in this simplified flow diagram.

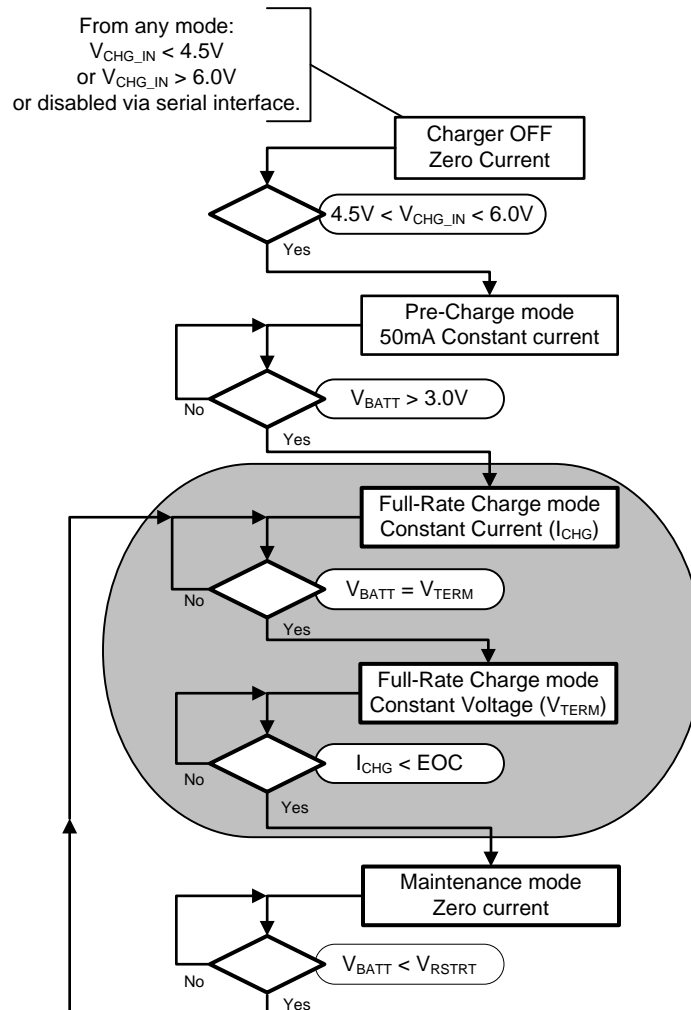

Figure 10. Simplified Charger Functional Flow Diagram (EOC is enabled)

The charger operation may be depicted by the following graphical representation of the voltage and current profiles.

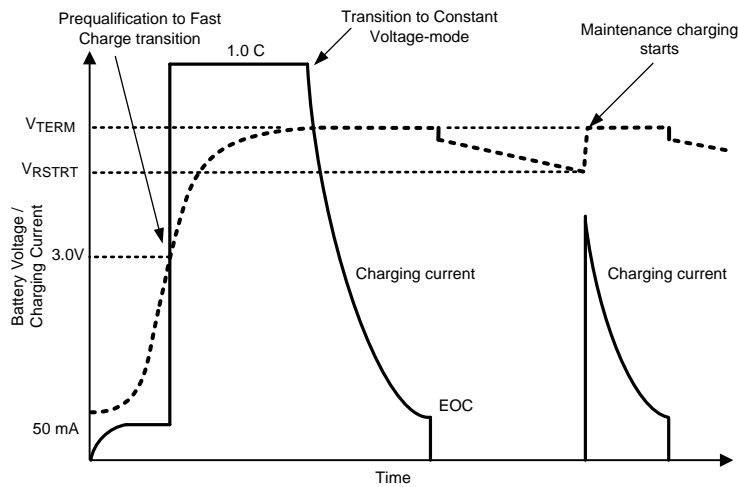

Figure 11. Charge Cycle Diagram

Further Charger Register Information

Charger Control Register 1

Table 14. Register Address 8h'10: CHGCNTL1

BIT	NAME	FUNCTION (if bit = '1')
7	USB_MODE_EN	Sets the Current Level in USB mode.
6	CHG_MODE_EN	Forces the charger into USB mode when active high. If low, charger is in normal charge mode.
5	FORCE_EOC	Forces an EOC event.
4	TOUT_Doubling	Doubles the timeout delays for all timeout signals.
3	EN_Tout	Enables the timeout counters. When set to '0' the timeout counters are disabled.
2	EN_EOC	Enables the End of Charge current level threshold detection. When set to '0' the functions are disabled.
1	Set_LDOmode	Forces the charger into LDO mode. Function available on LP3918TL_L.
0	EN_CHG	Charger enable.

Charger Status Register 1 Read only

Table 15. Register Address 8h'13: CHGSTATUS1

BIT	NAME	FUNCTION (if bit = '1')
7	BAT_OVER_OUT	Is set when battery voltage exceeds 4.7V.
6	CHGIN_OK_Out	Is set when a valid input voltage is detected at CHG_IN pin.
5	EOC	Is set when the charging current decreases below the programmed End Of Charge level.
4	Tout_Fullrate	Set after timeout on full rate charge.
3	Tout_Precharge	Set after timeout for precharge mode.
2	LDO_Mode	Only available on LP3918TL_L.

Table 15. Register Address 8h'13: CHGSTATUS1 (continued)

BIT	NAME	FUNCTION (if bit = '1')
1	Fullrate	Set when the charger is in CC/CV mode.
0	PRECHG	Set during precharge.

Charger Status Register 2 Read only

Table 16. Register Address 8h'13: CHGSTATUS2

BIT	NAME	FUNCTION (if bit = '1')
1	Tout_ ConstV	Set after timeout in CV phase.
0	BAD_ BATT	Set at bad battery state.

IMON CHARGE CURRENT MONITOR

Charge current is monitored within the charger section and a proportional voltage representation of the charge current is presented at the IMON output pin. The output voltage relationship to the actual charge current is represented in the following graph and by the equation:

$$V_{\text{IMON}}(\text{mV}) = (2.47 \times I_{\text{CHG}})(\text{mA})$$

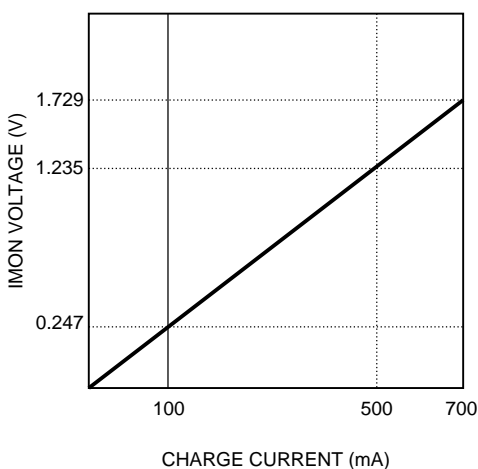

Figure 12. IMON Voltage vs Charge Current

Note that this function is not available if there is no input at CHG_IN or if the charger is off due to the input at CHG_IN being outwith the operating voltage range.

LDO Information

OPERATIONAL INFORMATION

The LP3918 has 7 LDO's of which 3 are enabled by default, LDO's 1,2 and 3 are powered up during the power up sequence. LDO4, 5 and 6 are separately, externally enabled and will follow LDO2 in start up if their respective enable pin is pulled high. LDO2, LDO3 and LDO7 can be enabled/disabled via the serial interface.

LDO2 must remain in regulation otherwise the device will power down. While LDO1 is enabled this must also be in regulation for the device to remain powered. If LDO1 is disabled via I2C interface the device will not shut down.

INPUT VOLTAGES

There are two input voltage pins used to power the 7LDO's on the LP3918. V_{IN2} is the supply for LDO3, LDO4, LDO5, LDO6 and LDO7. V_{IN1} is the supply for LDO1 and LDO2. These input voltages should be tied to the Batt pin in the application.

PROGRAMMING INFORMATION

Enable via Serial Interface

Table 17. Register Address 8h'00: OP_EN

BIT	NAME	FUNCTION
0	LDO1_EN	Bit set to '0' - LDO disabled Bit set to '1' - LDO enabled
2	LDO3_EN	
3	LDO7_EN	

Note that the default setting for this Register is **[0000 0101]**. This shows that LDO1 and 3 are enabled by default whereas LDO7 is not enabled by default on start up.

LDO OUTPUT PROGRAMMING

Table 18.

Register Add (hex)	NAME	Data Range (hex) ⁽¹⁾	Output Voltage
01	LDO1PGM O/P	03 - 0F	1.5V to 3.3V (def. 1.8V)
02	LDO2PGM O/P	00 - 0F	2.5V to 3.3V (def 3.0V)
03	LDO3PGM O/P	05 - 0C	2.7V to 3.05V (def 3.0V)
04	LDO4PGM O/P	00 - 0F	1.5V to 3.3V (def 3.0V)
05	LDO5PGM O/P	05 - 0C	2.7V to 3.05V (def 3.0V)
06	LDO6PGM O/P	05 - 0C	2.7V to 3.05V (def 3.0V)
07	LDO7PGM O/P	00 - 0F	1.5V to 3.3V (def 3.0V)

(1) See [Table 2](#) for full programmable range of values.

EXTERNAL CAPACITORS

The Low Drop Out Linear Voltage regulators on the LP3918 require external capacitors to ensure stable outputs. The LDO's on the LP3918 are specifically designed to use small surface mount ceramic capacitors which require minimum board space. These capacitors must be correctly selected for good performance

INPUT CAPACITOR

Input capacitors are required for correct operation. It is recommended that a 10 μ F capacitor be connected between each of the voltage input pins and ground (this capacitance value may be increased without limit). This capacitor must be located a distance of not more than 1cm from the input pin and returned to a clean analogue ground. A ceramic capacitor is recommended although a good quality tantalum or film capacitor may be used at the input.

Important: Tantalum capacitors can suffer catastrophic failures due to surge current when connected to a low-impedance source of power (like a battery or a very large capacitor). If a tantalum capacitor is used at the input, it must be specified by the manufacturer to have surge current rating sufficient for the application. There are no requirements for the ESR (Equivalent Series Resistance) on the input capacitor, but tolerance and temperature coefficient must be considered when selecting the capacitor to ensure the capacitance will remain within its operational range over the entire operating temperature range and conditions.

Output Capacitor

Correct selection of the output capacitor is critical to ensure stable operation in the intended application. The output capacitor must meet all the requirements specified in the recommended capacitor table over all conditions in the application. These conditions include DC-bias, frequency and temperature. Unstable operation will result if the capacitance drops below the minimum specified value. The LP3918 is designed specifically to work with very small ceramic output capacitors. The LDO's on the LP3918 are specifically designed to be used with X7R and X5R type capacitors. With these capacitors selection of the capacitor for the application is dependant on the range of operating conditions and temperature range for that application. (See section on [Capacitor Characteristics](#)). It is also recommended that the output capacitor be placed within 1cm from the output pin and returned to a clean ground line.

Capacitor Characteristics

The LDO's on the LP3918 are designed to work with ceramic capacitors on the input and output to take advantage of the benefits they offer. For capacitance values around 1 μ F, ceramic capacitors give the circuit designer the best design options in terms of low cost and minimal area. For both input and output capacitors careful interpretation of the capacitor specification is required to ensure correct device operation. The capacitor value can change greatly dependant on the conditions of operation and capacitor type. In particular to ensure stability, the output capacitor selection should take account of all the capacitor parameters to ensure that the specification is met within the application. Capacitance value can vary with DC bias conditions as well as temperature and frequency of operation. Capacitor values will also show some decrease over time due to aging. The capacitor parameters are also dependant on the particular case size with smaller sizes giving poorer performance figures in general.

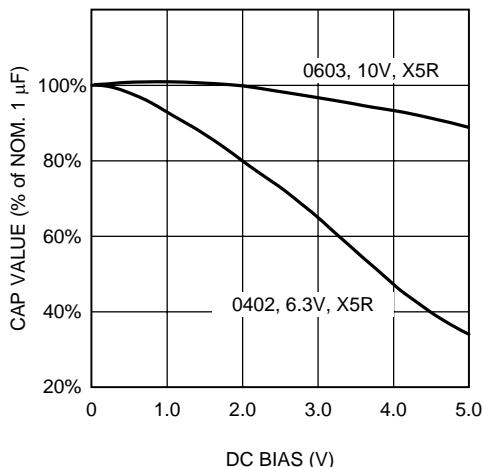

Figure 13. Graph Showing A Typical Variation in Capacitance vs DC Bias

As an example [Figure 13](#) shows a typical graph showing a comparison of capacitor case sizes in a Capacitance vs DC Bias plot. As shown in the graph, as a result of DC Bias condition the capacitance value may drop below minimum capacitance value given in the recommended capacitor table (0.7 μ F in this case). Note that the graph shows the capacitance out of spec for 0402 case size capacitor at higher bias voltages. It is therefore recommended that the capacitor manufacturers specifications for the nominal value capacitor are consulted for all conditions as some capacitor sizes (e.g 0402) may not be suitable in the actual application. Ceramic capacitors have the lowest ESR values, thus making them best for eliminating high frequency noise. The ESR of a typical 1 μ F ceramic capacitor is in the range of 20m Ω to 40m Ω , and also meets the ESR requirements for stability. The temperature performance of ceramic capacitors varies by type. Capacitor type X7R is specified with a tolerance of \pm 15% over temperature range -55 $^{\circ}$ C to +125 $^{\circ}$ C. The X5R has similar tolerance over the reduced temperature range -55 $^{\circ}$ C to +85 $^{\circ}$ C. Most large value ceramic capacitors (<2.2 μ F) are manufactured with Z5U or Y5V temperature characteristics, which results in the capacitance dropping by more than 50% as the temperature goes from 25 $^{\circ}$ C to 85 $^{\circ}$ C. Therefore X7R is recommended over these other capacitor types in applications where the temperature will change significantly above or below 25 $^{\circ}$ C.

No-Load Stability

The LDO's on the LP3918 will remain stable in regulation with no external load.

Table 19. LDO Output Capacitors Recommended Specification

Symbol	Parameter	Capacitor Type	Typ	Limit		Units
				Min	Max	
C _o (LDO1)	Capacitance	X5R. X74	1.0	0.7	2.2	μF
C _o (LDO2)	Capacitance	X5R. X74	1.0	0.7	2.2	μF
C _o (LDO3)	Capacitance	X5R. X74	1.0	0.7	2.2	μF
C _o (LDO4)	Capacitance	X5R. X74	1.0	0.7	2.2	μF
C _o (LDO5)	Capacitance	X5R. X74	1.0	0.7	2.2	μF
C _o (LDO6)	Capacitance	X5R. X74	1.0	0.7	2.2	μF
C _o (LDO7)	Capacitance	X5R. X74	1.0	0.7	2.2	μF

Note: The capacitor tolerance should be 30% or better over the full temperature range. X7R or X5R capacitors should be used. These specifications are given to ensure that the capacitance remains within these values over all conditions within the application. See [Capacitor Characteristics](#).

Thermal Shutdown

The LP3918 has internal limiting for high on-chip temperatures caused by high power dissipation etc. This Thermal Shutdown, TSD, function monitors the temperature with respect to a threshold and results in a device power-down.

If the threshold of +160°C has been exceeded then the device will power down. Recovery from this TSD event can only be initiated after the chip has cooled below +115°C. This device recovery is controlled by the APU_TSD_EN bit (bit 1) in control register MISC, 8h'1C. See [Table 21](#) If the APU_TSD_EN is set low then the device will shutdown requiring a new start up event initiated by PWR_ON, HF_PWR, or CHG_IN. If APU_TSD_EN is set high then the device will power up automatically when the shutdown condition clears. In this case the control register settings are preserved for the device restart.

The threshold temperature for the device to clear this TSD event is 115°C. This threshold applies for any start up thus the device temperature must be below this threshold to allow a start up event to initiate power up.

Further Register Information

STATUS REGISTER READ ONLY

Table 20. Register Address 8h'0C: Status⁽¹⁾

BIT	NAME	FUNCTION (if bit = '1')
7	PWR_ON_TRIG	PMU start up is initiated by PWR_ON.
6	HF_PWR_TRIG	PMU start up is initiated by HF_PWR.
5	CHG_IN_TRIG	PMU start up is initiated by CHG_IN.

(1) Bits <4..0> are not used.

MISC CONTROL REGISTER

Table 21. Register Address 8h'1C: Misc⁽¹⁾

BIT	NAME	FUNCTION (if bit = '1')
1	APU_TSD_EN	1b'0: Device will shutdown completely if thermal shutdown occurs. Requires a new start up event to restart the PMU. 1b'1: Device will start up automatically after thermal shutdown condition is removed. (Device tries to keep its internal state.)

(1) Bits <7..2> are not used.

Table 21. Register Address 8h'1C: Misc⁽¹⁾ (continued)

BIT	NAME	FUNCTION (if bit = '1')
0	PWR_HOLD DELAY	1b'0: If PWR_HOLD is low for 35ms the device will shutdown. (Default) 1b'1: If PWR_HOLD is low for 350ms the device will shutdown.

I²C Compatible Serial Bus Interface

INTERFACE BUS OVERVIEW

The I²C compatible synchronous serial interface provides access to the programmable functions and registers on the device.

This protocol uses a two-wire interface for bi-directional communications between the IC's connected to the bus. The two interface lines are the Serial Data Line (SDA), and the Serial Clock Line (SCL). These lines should be connected to a positive supply, via a pull-up resistor of 1.5KΩ, and remain HIGH even when the bus is idle.

Every device on the bus is assigned a unique address and acts as either a Master or a Slave depending on whether it generates or receives the serial clock (SCL).

DATA TRANSACTIONS

One data bit is transferred during each clock pulse. Data is sampled during the high state of the serial clock (SCL). Consequently, throughout the clock's high period, the data should remain stable. Any changes on the SDA line during the high state of the SCL and in the middle of a transaction, aborts the current transaction. New data should be sent during the low SCL state. This protocol permits a single data line to transfer both command/control information and data using the synchronous serial clock.

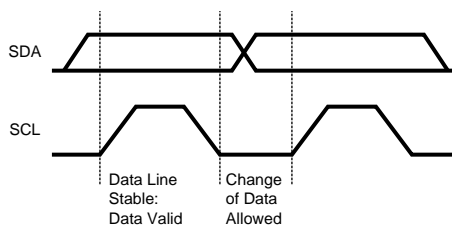

Figure 14. Bit Transfer

Each data transaction is composed of a Start Condition, a number of byte transfers (set by the software) and a Stop Condition to terminate the transaction. Every byte written to the SDA bus must be 8 bits long and is transferred with the most significant bit first. After each byte, an Acknowledge signal must follow. The following sections provide further details of this process.

START AND STOP

The Master device on the bus always generates the Start and Stop Conditions (control codes). After a Start Condition is generated, the bus is considered busy and it retains this status until a certain time after a Stop Condition is generated. A high-to-low transition of the data line (SDA) while the clock (SCL) is high indicates a Start Condition. A low-to-high transition of the SDA line while the SCL is high indicates a Stop Condition.

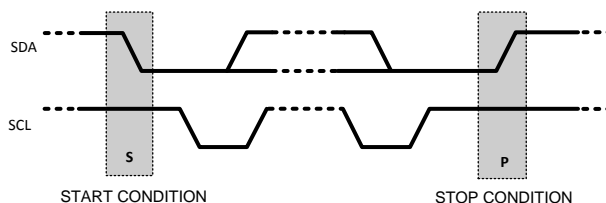

Figure 15. Start and Stop Conditions

In addition to the first Start Condition, a repeated Start Condition can be generated in the middle of a transaction. This allows another device to be accessed, or a register read cycle.

ACKNOWLEDGE CYCLE

The Acknowledge Cycle consists of two signals: the acknowledge clock pulse the master sends with each byte transferred, and the acknowledge signal sent by the receiving device.

The master generates the acknowledge clock pulse on the ninth clock pulse of the byte transfer. The transmitter releases the SDA line (permits it to go high) to allow the receiver to send the acknowledge signal. The receiver must pull down the SDA line during the acknowledge clock pulse and ensure that SDA remains low during the high period of the clock pulse, thus signaling the correct reception of the last data byte and its readiness to receive the next byte.

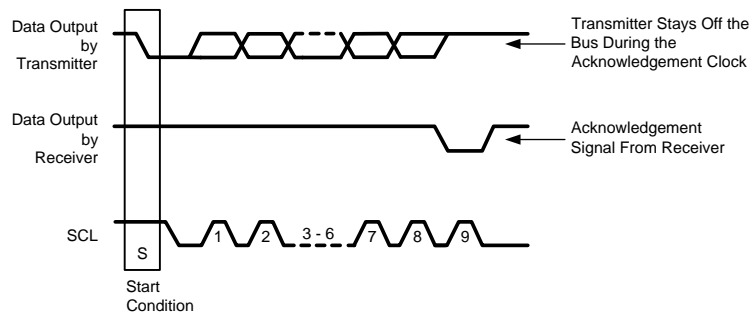

Figure 16. Bus Acknowledge Cycle

“ACKNOWLEDGE AFTER EVERY BYTE” RULE

The master generates an acknowledge clock pulse after each byte transfer. The receiver sends an acknowledge signal after every byte received.

There is one exception to the “acknowledge after every byte” rule.

When the master is the receiver, it must indicate to the transmitter an end of data by not-acknowledging (“negative acknowledge”) the last byte clocked out of the slave. This “negative acknowledge” still includes the acknowledge clock pulse (generated by the master), but the SDA line is not pulled down.

ADDRESSING TRANSFER FORMATS

Each device on the bus has a unique slave address. The LP3918 operates as a slave device with the address 7h'7E (binary 1111110). Before any data is transmitted, the master transmits the address of the slave being addressed. The slave device should send an acknowledge signal on the SDA line, once it recognizes its address.

The slave address is the first seven bits after a Start Condition. The direction of the data transfer (R/W) depends on the bit sent after the slave address — the eighth bit.

When the slave address is sent, each device in the system compares this slave address with its own. If there is a match, the device considers itself addressed and sends an acknowledge signal. Depending upon the state of the R/W bit (1:read, 0:write), the device acts as a transmitter or a receiver.

CONTROL REGISTER WRITE CYCLE

- Master device generates start condition.
- Master device sends slave address (7 bits) and the data direction bit (r/w = “0”).
- Slave device sends acknowledge signal if the slave address is correct.
- Master sends control register address (8 bits).
- Slave sends acknowledge signal.
- Master sends data byte to be written to the addressed register.
- Slave sends acknowledge signal.
- If master will send further data bytes the control register address will be incremented by one after acknowledge signal.

- Write cycle ends when the master creates stop condition.

CONTROL REGISTER READ CYCLE

- Master device generates a start condition.
- Master device sends slave address (7 bits) and the data direction bit (r/w = “0”).
- Slave device sends acknowledge signal if the slave address is correct.
- Master sends control register address (8 bits).
- Slave sends acknowledge signal.
- Master device generates repeated start condition.
- Master sends the slave address (7 bits) and the data direction bit (r/w = “1”).
- Slave sends acknowledge signal if the slave address is correct.
- Slave sends data byte from addressed register.
- If the master device sends acknowledge signal, the control register address will be incremented by one. Slave device sends data byte from addressed register.
- Read cycle ends when the master does not generate acknowledge signal after data byte and generates stop condition.

	Address Mode ⁽¹⁾
Data Read	<Start Condition> <Slave Address><r/w = '0'>[Ack] <Register Addr.>[Ack] <Repeated Start Condition> <Slave Address><r/w = '1'>[Ack] [Register Data]<Ack or nAck> ... additional reads from subsequent register address possible <Stop Condition>
Data Write	<Start Condition> <Slave Address><r/w = '0'>[Ack] <Register Addr.>[Ack] <Register Data>[Ack] ... additional writes to subsequent register address possible <Stop Condition>

(1) < > Data from master [] Data from slave

REGISTER READ AND WRITE DETAIL

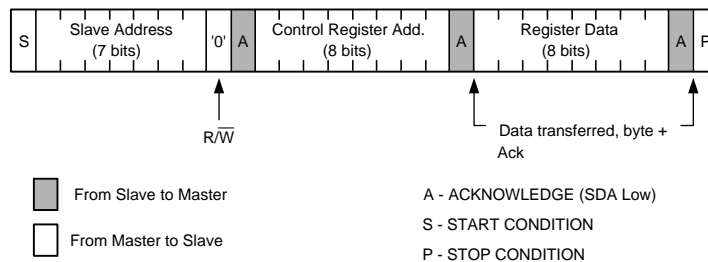

Figure 17. Register Write Format

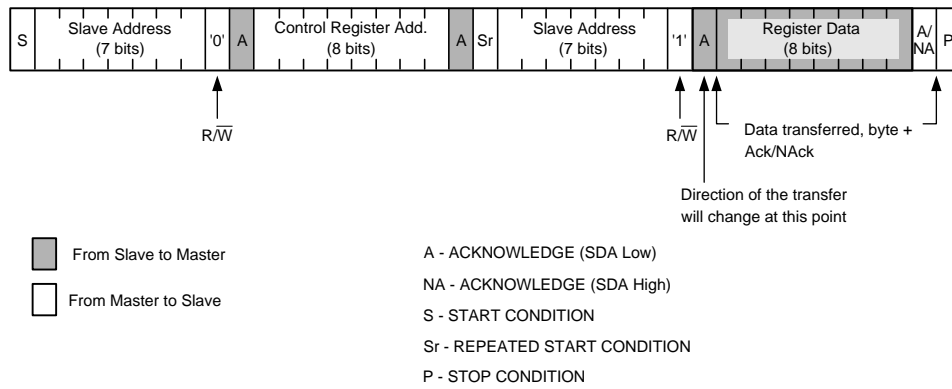

Figure 18. Register Read Format

REVISION HISTORY

Changes from Revision C (May 2013) to Revision D	Page
<hr/> <ul style="list-style-type: none">• Changed layout of National Data Sheet to TI format	<hr/> 31

PACKAGING INFORMATION

Orderable Device	Status (1)	Package Type	Package Drawing	Pins	Package Qty	Eco Plan (2)	Lead/Ball Finish (6)	MSL Peak Temp (3)	Op Temp (°C)	Device Marking (4/5)	Samples
LP3918TL-A/NOPB	NRND	DSBGA	YZR	25	250	Green (RoHS & no Sb/Br)	SNAGCU	Level-1-260C-UNLIM	-40 to 125	V011	
LP3918TL/NOPB	NRND	DSBGA	YZR	25	250	Green (RoHS & no Sb/Br)	SNAGCU	Level-1-260C-UNLIM	-40 to 125	3918	

(1) The marketing status values are defined as follows:

ACTIVE: Product device recommended for new designs.

LIFEBUY: TI has announced that the device will be discontinued, and a lifetime-buy period is in effect.

NRND: Not recommended for new designs. Device is in production to support existing customers, but TI does not recommend using this part in a new design.

PREVIEW: Device has been announced but is not in production. Samples may or may not be available.

OBSELETE: TI has discontinued the production of the device.

(2) **RoHS:** TI defines "RoHS" to mean semiconductor products that are compliant with the current EU RoHS requirements for all 10 RoHS substances, including the requirement that RoHS substance do not exceed 0.1% by weight in homogeneous materials. Where designed to be soldered at high temperatures, "RoHS" products are suitable for use in specified lead-free processes. TI may reference these types of products as "Pb-Free".

RoHS Exempt: TI defines "RoHS Exempt" to mean products that contain lead but are compliant with EU RoHS pursuant to a specific EU RoHS exemption.

Green: TI defines "Green" to mean the content of Chlorine (Cl) and Bromine (Br) based flame retardants meet JS709B low halogen requirements of <=1000ppm threshold. Antimony trioxide based flame retardants must also meet the <=1000ppm threshold requirement.

(3) MSL, Peak Temp. - The Moisture Sensitivity Level rating according to the JEDEC industry standard classifications, and peak solder temperature.

(4) There may be additional marking, which relates to the logo, the lot trace code information, or the environmental category on the device.

(5) Multiple Device Markings will be inside parentheses. Only one Device Marking contained in parentheses and separated by a "~" will appear on a device. If a line is indented then it is a continuation of the previous line and the two combined represent the entire Device Marking for that device.

(6) Lead/Ball Finish - Orderable Devices may have multiple material finish options. Finish options are separated by a vertical ruled line. Lead/Ball Finish values may wrap to two lines if the finish value exceeds the maximum column width.

Important Information and Disclaimer:The information provided on this page represents TI's knowledge and belief as of the date that it is provided. TI bases its knowledge and belief on information provided by third parties, and makes no representation or warranty as to the accuracy of such information. Efforts are underway to better integrate information from third parties. TI has taken and continues to take reasonable steps to provide representative and accurate information but may not have conducted destructive testing or chemical analysis on incoming materials and chemicals. TI and TI suppliers consider certain information to be proprietary, and thus CAS numbers and other limited information may not be available for release.

In no event shall TI's liability arising out of such information exceed the total purchase price of the TI part(s) at issue in this document sold by TI to Customer on an annual basis.

TAPE AND REEL INFORMATION



QUADRANT ASSIGNMENTS FOR PIN 1 ORIENTATION IN TAPE



*All dimensions are nominal

Device	Package Type	Package Drawing	Pins	SPQ	Reel Diameter (mm)	Reel Width W1 (mm)	A0 (mm)	B0 (mm)	K0 (mm)	P1 (mm)	W (mm)	Pin1 Quadrant
LP3918TL-A/NOPB	DSBGA	YZR	25	250	178.0	8.4	2.69	2.69	0.76	4.0	8.0	Q1
LP3918TL/NOPB	DSBGA	YZR	25	250	178.0	8.4	2.69	2.69	0.76	4.0	8.0	Q1

TAPE AND REEL BOX DIMENSIONS

*All dimensions are nominal

Device	Package Type	Package Drawing	Pins	SPQ	Length (mm)	Width (mm)	Height (mm)
LP3918TL-A/NOPB	DSBGA	YZR	25	250	210.0	185.0	35.0
LP3918TL/NOPB	DSBGA	YZR	25	250	210.0	185.0	35.0

YZR0025

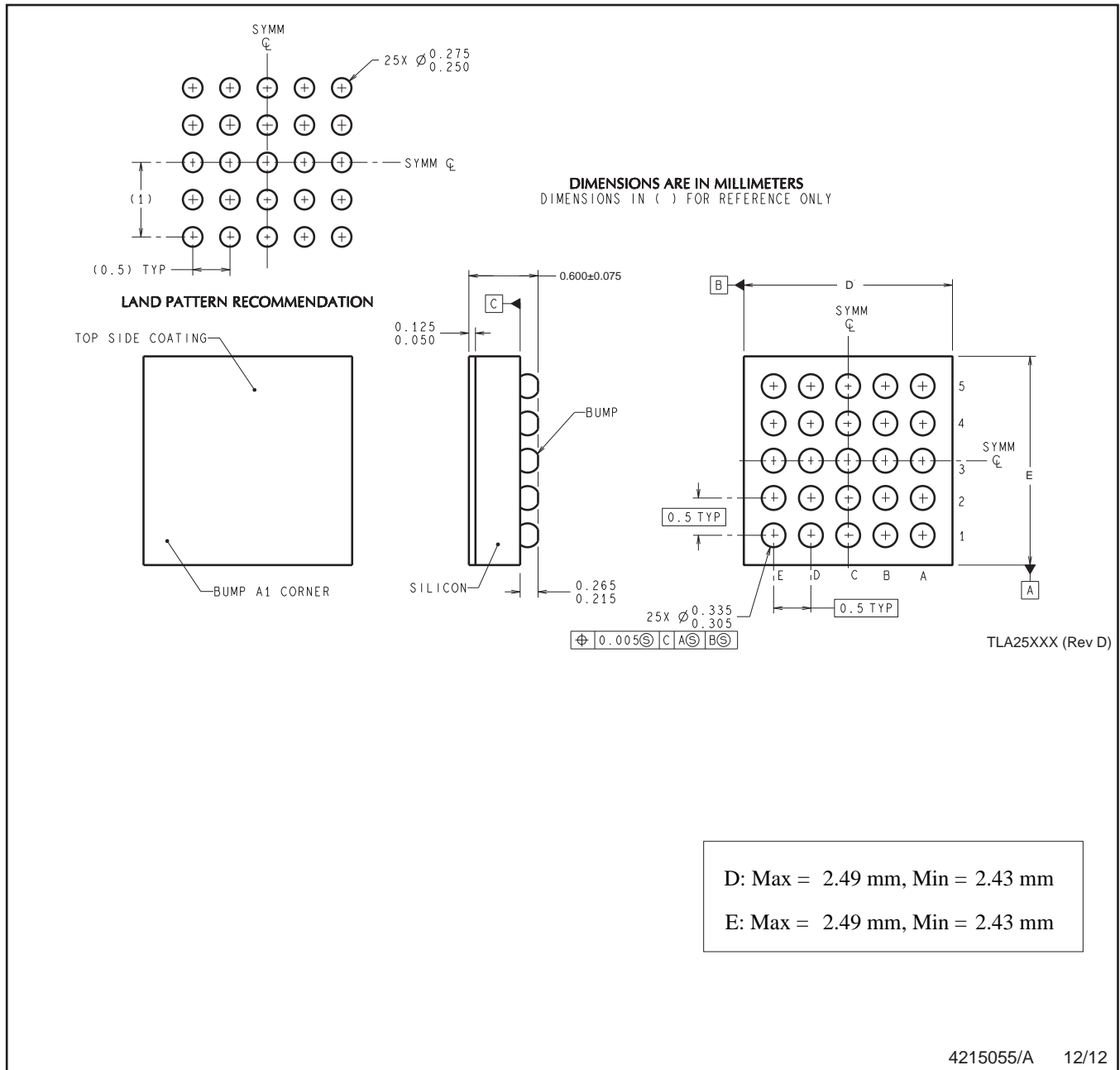

4215055/A 12/12

NOTES: A. All linear dimensions are in millimeters. Dimensioning and tolerancing per ASME Y14.5M-1994.
B. This drawing is subject to change without notice.

IMPORTANT NOTICE

Texas Instruments Incorporated (TI) reserves the right to make corrections, enhancements, improvements and other changes to its semiconductor products and services per JESD46, latest issue, and to discontinue any product or service per JESD48, latest issue. Buyers should obtain the latest relevant information before placing orders and should verify that such information is current and complete.

TI's published terms of sale for semiconductor products (<http://www.ti.com/sc/docs/stdterms.htm>) apply to the sale of packaged integrated circuit products that TI has qualified and released to market. Additional terms may apply to the use or sale of other types of TI products and services.

Reproduction of significant portions of TI information in TI data sheets is permissible only if reproduction is without alteration and is accompanied by all associated warranties, conditions, limitations, and notices. TI is not responsible or liable for such reproduced documentation. Information of third parties may be subject to additional restrictions. Resale of TI products or services with statements different from or beyond the parameters stated by TI for that product or service voids all express and any implied warranties for the associated TI product or service and is an unfair and deceptive business practice. TI is not responsible or liable for any such statements.

Buyers and others who are developing systems that incorporate TI products (collectively, "Designers") understand and agree that Designers remain responsible for using their independent analysis, evaluation and judgment in designing their applications and that Designers have full and exclusive responsibility to assure the safety of Designers' applications and compliance of their applications (and of all TI products used in or for Designers' applications) with all applicable regulations, laws and other applicable requirements. Designer represents that, with respect to their applications, Designer has all the necessary expertise to create and implement safeguards that (1) anticipate dangerous consequences of failures, (2) monitor failures and their consequences, and (3) lessen the likelihood of failures that might cause harm and take appropriate actions. Designer agrees that prior to using or distributing any applications that include TI products, Designer will thoroughly test such applications and the functionality of such TI products as used in such applications.

TI's provision of technical, application or other design advice, quality characterization, reliability data or other services or information, including, but not limited to, reference designs and materials relating to evaluation modules, (collectively, "TI Resources") are intended to assist designers who are developing applications that incorporate TI products; by downloading, accessing or using TI Resources in any way, Designer (individually or, if Designer is acting on behalf of a company, Designer's company) agrees to use any particular TI Resource solely for this purpose and subject to the terms of this Notice.

TI's provision of TI Resources does not expand or otherwise alter TI's applicable published warranties or warranty disclaimers for TI products, and no additional obligations or liabilities arise from TI providing such TI Resources. TI reserves the right to make corrections, enhancements, improvements and other changes to its TI Resources. TI has not conducted any testing other than that specifically described in the published documentation for a particular TI Resource.

Designer is authorized to use, copy and modify any individual TI Resource only in connection with the development of applications that include the TI product(s) identified in such TI Resource. NO OTHER LICENSE, EXPRESS OR IMPLIED, BY ESTOPPEL OR OTHERWISE TO ANY OTHER TI INTELLECTUAL PROPERTY RIGHT, AND NO LICENSE TO ANY TECHNOLOGY OR INTELLECTUAL PROPERTY RIGHT OF TI OR ANY THIRD PARTY IS GRANTED HEREIN, including but not limited to any patent right, copyright, mask work right, or other intellectual property right relating to any combination, machine, or process in which TI products or services are used. Information regarding or referencing third-party products or services does not constitute a license to use such products or services, or a warranty or endorsement thereof. Use of TI Resources may require a license from a third party under the patents or other intellectual property of the third party, or a license from TI under the patents or other intellectual property of TI.

TI RESOURCES ARE PROVIDED "AS IS" AND WITH ALL FAULTS. TI DISCLAIMS ALL OTHER WARRANTIES OR REPRESENTATIONS, EXPRESS OR IMPLIED, REGARDING RESOURCES OR USE THEREOF, INCLUDING BUT NOT LIMITED TO ACCURACY OR COMPLETENESS, TITLE, ANY EPIDEMIC FAILURE WARRANTY AND ANY IMPLIED WARRANTIES OF MERCHANTABILITY, FITNESS FOR A PARTICULAR PURPOSE, AND NON-INFRINGEMENT OF ANY THIRD PARTY INTELLECTUAL PROPERTY RIGHTS. TI SHALL NOT BE LIABLE FOR AND SHALL NOT DEFEND OR INDEMNIFY DESIGNER AGAINST ANY CLAIM, INCLUDING BUT NOT LIMITED TO ANY INFRINGEMENT CLAIM THAT RELATES TO OR IS BASED ON ANY COMBINATION OF PRODUCTS EVEN IF DESCRIBED IN TI RESOURCES OR OTHERWISE. IN NO EVENT SHALL TI BE LIABLE FOR ANY ACTUAL, DIRECT, SPECIAL, COLLATERAL, INDIRECT, PUNITIVE, INCIDENTAL, CONSEQUENTIAL OR EXEMPLARY DAMAGES IN CONNECTION WITH OR ARISING OUT OF TI RESOURCES OR USE THEREOF, AND REGARDLESS OF WHETHER TI HAS BEEN ADVISED OF THE POSSIBILITY OF SUCH DAMAGES.

Unless TI has explicitly designated an individual product as meeting the requirements of a particular industry standard (e.g., ISO/TS 16949 and ISO 26262), TI is not responsible for any failure to meet such industry standard requirements.

Where TI specifically promotes products as facilitating functional safety or as compliant with industry functional safety standards, such products are intended to help enable customers to design and create their own applications that meet applicable functional safety standards and requirements. Using products in an application does not by itself establish any safety features in the application. Designers must ensure compliance with safety-related requirements and standards applicable to their applications. Designer may not use any TI products in life-critical medical equipment unless authorized officers of the parties have executed a special contract specifically governing such use. Life-critical medical equipment is medical equipment where failure of such equipment would cause serious bodily injury or death (e.g., life support, pacemakers, defibrillators, heart pumps, neurostimulators, and implantables). Such equipment includes, without limitation, all medical devices identified by the U.S. Food and Drug Administration as Class III devices and equivalent classifications outside the U.S.

TI may expressly designate certain products as completing a particular qualification (e.g., Q100, Military Grade, or Enhanced Product). Designers agree that it has the necessary expertise to select the product with the appropriate qualification designation for their applications and that proper product selection is at Designers' own risk. Designers are solely responsible for compliance with all legal and regulatory requirements in connection with such selection.

Designer will fully indemnify TI and its representatives against any damages, costs, losses, and/or liabilities arising out of Designer's non-compliance with the terms and provisions of this Notice.

Looking for pricing, stock, or lifecycle information?

Click below to explore more details on WIN SOURCE:

- ⊖ [View LP3918TL-A/NOPB on WIN SOURCE](#)
- ⊖ [Texas Instruments](#) Information

Optimize Your Supply Chain with WIN SOURCE Solutions

- ✓ Global Sourcing Solution
- ✓ Obsolete Management
- ✓ Cost Control Management
- ✓ Shortage Management
- ✓ Alternative Solution
- ✓ Excess Inventory Management