



# THE DATASHEET OF LMV822IDT



## Low power, high accuracy, general-purpose operational amplifier

Datasheet — production data

### Features

- Low power consumption: 400  $\mu$ A max at 5 V
- Low power shutdown mode: 50 nA max
- Low offset voltage: 0.8 mV max at 25°C
- Tiny packages
- Extended temperature range: -40°C to +125°C
- Low supply voltage: 2.5 V - 5.5 V
- Gain bandwidth product: 5.5 MHz
- Automotive qualification

### Benefits

- Longer lifetime in battery-powered applications
- Higher accuracy without calibration
- Smaller form factor than equivalent competitor devices
- Application performances guaranteed over wide temperature range

### Related products

- See TSV85x series for lower power consumption (180  $\mu$ A max at 5 V)

### Applications

- Battery-powered applications
- Portable devices
- Automotive signal conditioning
- Active filtering
- Medical instrumentation

### Description

The LMV82x and LMV82xA series of single, dual, and quad operational amplifiers offer low voltage operation with rail-to-rail output swing. They outperform the industry standard LMV321, especially with regard to the gain bandwidth

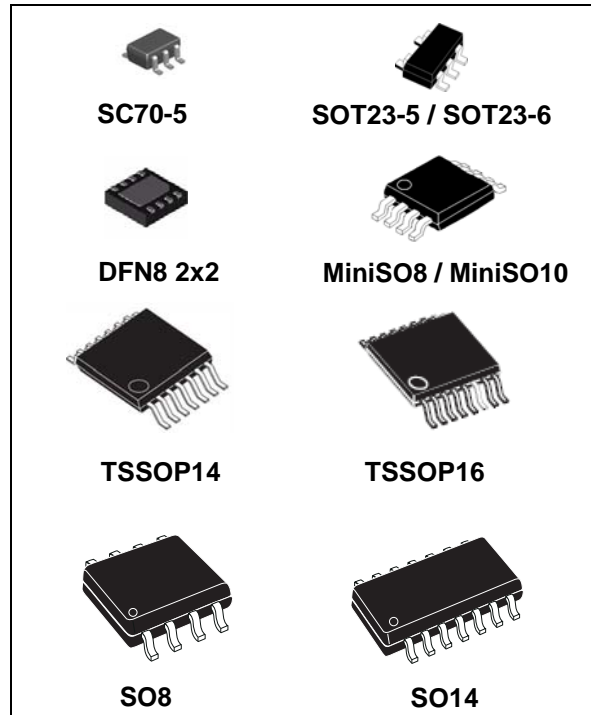

product (5.5 MHz). The LMV821, LMV822 and LMV824 are offered with standard pinouts.

The LMV820, LMV823, and LMV825 include a power-saving shutdown feature that reduces the supply current to a maximum of 50 nA at 25 °C.

The wide temperature range, high ESD tolerance, and automotive grade qualification make them particularly suitable for use in harsh automotive applications.

**Table 1. Device summary**

	Without shutdown		With shutdown	
	Standard Vio	Enhanced Vio	Standard Vio	Enhanced Vio
Single	LMV821	LMV821A	LMV820	LMV820A
Dual	LMV822	LMV822A	LMV823	LMV823A
Quad	LMV824	LMV824A	LMV825	LMV825A

# Contents

- 1 Package pin connections ..... 3**
- 2 Absolute maximum ratings and operating conditions ..... 4**
- 3 Electrical characteristics ..... 6**
- 4 Application information ..... 16**
  - 4.1 Operating voltages ..... 16
  - 4.2 Input common mode range ..... 16
  - 4.3 Rail-to-rail output ..... 16
  - 4.4 Input offset voltage drift over temperature ..... 16
  - 4.5 PCB layouts ..... 16
  - 4.6 Macromodel ..... 16
  - 4.7 Shutdown function ..... 17
- 5 Package information ..... 18**
  - 5.1 SC70-5 (or SOT323-5) package information ..... 19
  - 5.2 SOT23-5 package information ..... 20
  - 5.3 SOT23-6 package information ..... 21
  - 5.4 DFN8 2 x 2 mm package information ..... 22
  - 5.5 MiniSO-8 package information ..... 23
  - 5.6 MiniSO-10 package information ..... 24
  - 5.7 TSSOP14 package information ..... 25
  - 5.8 TSSOP16 package information ..... 26
  - 5.9 SO-8 package information ..... 27
  - 5.10 SO-14 package information ..... 28
- 6 Ordering information ..... 29**
- 7 Revision history ..... 31**

# 1 Package pin connections

Figure 1. Pin connections for each package (top view)

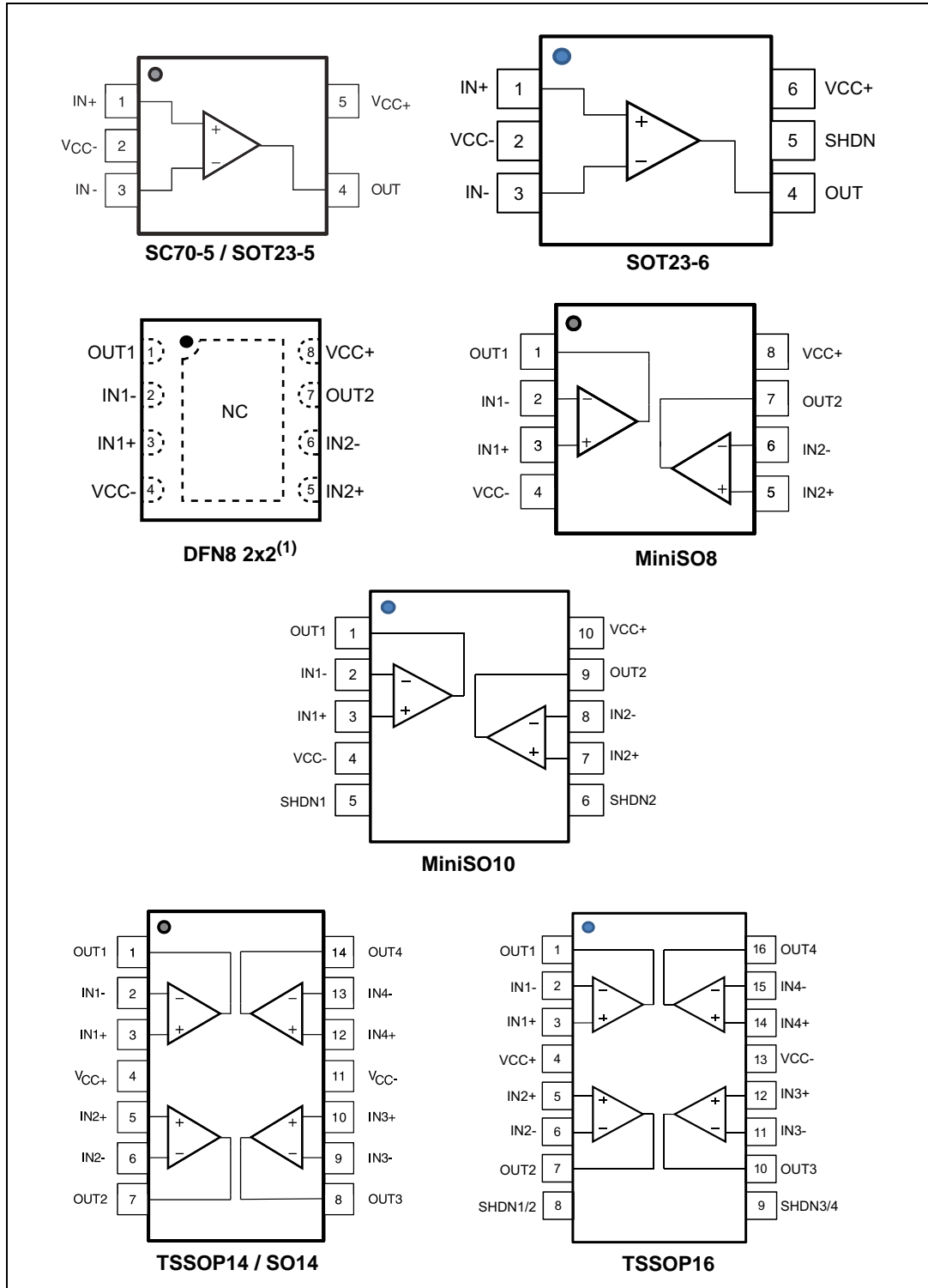

1. The exposed pad of DFN8 2x2 can be connected to VCC- or left floating.

## 2 Absolute maximum ratings and operating conditions

**Table 2. Absolute maximum ratings (AMR)**

Symbol	Parameter	Value	Unit
$V_{CC}$	Supply voltage <sup>(1)</sup>	6	V
$V_{id}$	Differential input voltage <sup>(2)</sup>	$\pm V_{CC}$	
$V_{in}$	Input pins (IN+ and IN- pins) voltage <sup>(3)</sup>	$V_{CC-} - 0.3$ to $V_{CC+} + 0.3$	
$I_{in}$	Input current <sup>(4)</sup>	10	mA
SHDN	Shutdown voltage <sup>(5)</sup>	$V_{CC-} - 0.2$ to $V_{CC+} + 0.2$	V
$T_{stg}$	Storage temperature	-65 to +150	°C
$R_{thja}$	Thermal resistance junction to ambient <sup>(6)(7)</sup>		°C/W
	– SC70-5	205	
	– SOT23-5	250	
	– DFN8 2x2	57	
	– MiniSO8	190	
	– SO8	125	
	– TSSOP14	100	
	– SO14	105	
	– SOT23-6	240	
	– MiniSO10	113	
– TSSOP16	95		
$T_j$	Maximum junction temperature	150	°C
ESD	HBM: human body model (except shutdown pin) <sup>(8)</sup>	4	kV
	HBM: human body model (shutdown pin) <sup>(8)</sup>	3.5	
	MM: machine model <sup>(9)</sup>	250	V
	CDM: charged device model <sup>(10)</sup>	1.3	kV
	CDM: charged device model LMV825 <sup>(10)</sup>	1	
	Latch-up immunity	200	mA

1. All voltage values, except the differential voltage are with respect to the network ground terminal.
2. Differential voltages are the non-inverting input terminal with respect to the inverting input terminal.
3.  $V_{CC-} - V_{in}$  must not exceed 6 V,  $V_{in}$  must not exceed 6 V.
4. The input current must be limited by a resistor in series with the inputs.
5.  $V_{CC-} - V_{shdn}$  must not exceed 6 V,  $V_{in}$  must not exceed 6 V.
6. Short-circuits can cause excessive heating and destructive dissipation.
7.  $R_{th}$  are typical values.
8. Human body model: a 100 pF capacitor is discharged through a 1.5 kΩ resistor between two pins of the device. This is done for all couples of pin combinations while other pins are floating.
9. Machine model: a 200 pF capacitor is charged to the specified voltage, then discharged directly between two pins of the device with no external series resistor (internal resistor < 5 Ω). This is done for all couples of pin combinations while other pins are floating.
10. Charged device model: all pins and package are charged together to the specified voltage and then discharged directly to ground.

Table 3. Operating conditions

Symbol	Parameter	Value	Unit
$V_{CC}$	Supply voltage	2.5 to 5.5	V
$V_{ICM}$	Common mode input voltage range	$V_{CC-} - 0.2$ to $V_{CC+} - 1$	
$T_{oper}$	Operating free air temperature range	-40 to +125	°C

### 3 Electrical characteristics

Table 4. Electrical characteristics at  $V_{CC+} = 2.5\text{ V}$  with  $V_{CC-} = 0\text{ V}$ ,  $V_{icm} = V_{CC}/2$ ,  $T_{amb} = 25^\circ\text{ C}$ , and  $R_L$  connected to  $V_{CC}/2$  (unless otherwise specified)

Symbol	Parameter	Conditions	Min.	Typ.	Max.	Unit
<b>DC performance</b>						
$V_{io}$	Input offset voltage	LMV82xA			0.8	mV
		LMV82x			3.5	
		LMV82xA, $-40^\circ\text{ C} < T < 125^\circ\text{ C}$			2	
		LMV82x, $-40^\circ\text{ C} < T < 125^\circ\text{ C}$			4	
$V_{CC-V_{OH}}$	High level output voltage	$R_L = 600\ \Omega$			220	
		$R_L = 600\ \Omega, -40^\circ\text{ C} < T < 125^\circ\text{ C}$			320	
		$R_L = 2\ \text{k}\Omega$			120	
		$R_L = 2\ \text{k}\Omega, -40^\circ\text{ C} < T < 125^\circ\text{ C}$			220	
$V_{OL}$	Low level output voltage	$R_L = 600\ \Omega$			220	
		$R_L = 600\ \Omega, -40^\circ\text{ C} < T < 125^\circ\text{ C}$			320	
		$R_L = 2\ \text{k}\Omega$			120	
		$R_L = 2\ \text{k}\Omega, -40^\circ\text{ C} < T < 125^\circ\text{ C}$			200	
$I_{out}$	$I_{sink} (V_{out} = V_{CC})$ $V_{id} = -1\text{ V}$		5			mA
		$-40^\circ\text{ C} < T < 125^\circ\text{ C}$	5			
	$I_{source} (V_{out} = 0\text{ V})$ $V_{id} = 1\text{ V}$		5			
		$-40^\circ\text{ C} < T < 125^\circ\text{ C}$	5			

Table 5. Shutdown characteristics  $V_{CC} = 2.5\text{ V}$ 

Symbol	Parameter	Conditions	Min.	Typ.	Max.	Unit
<b>DC performance</b>						
$I_{CC}$	Supply current in shutdown mode (all operators) $\overline{\text{SHDN}} = V_{CC-}$	$T = 25\text{ }^\circ\text{C}$		2.5	50	nA
		$-40\text{ }^\circ\text{C} < T < 85\text{ }^\circ\text{C}$			200	
		$-40\text{ }^\circ\text{C} < T < 125\text{ }^\circ\text{C}$				1.5
$t_{on}$	Amplifier turn-on time <sup>(1)</sup>	$R_L = 2\text{ k}\Omega$ , $V_{out} = V_{CC-}$ to $V_{CC-} + 0.2\text{ V}$		300		ns
$t_{off}$	Amplifier turn-off time <sup>(1)</sup>	$R_L = 2\text{ k}\Omega$ , $V_{out} = V_{CC+} - 1\text{ V}$ to $V_{CC+} - 1.2\text{ V}$		20		
$V_{IH}$	$\overline{\text{SHDN}}$ logic high		$V_{CC-0.5}$			V
$V_{IL}$	$\overline{\text{SHDN}}$ logic low				0.5	
$I_{IH}$	$\overline{\text{SHDN}}$ current high	$\overline{\text{SHDN}} = V_{CC+}$		10		pA
$I_{IL}$	$\overline{\text{SHDN}}$ current low	$\overline{\text{SHDN}} = V_{CC-}$		10		
$I_{OLeak}$	Output leakage in shutdown mode	$\overline{\text{SHDN}} = V_{CC-}$		50		
		$-40\text{ }^\circ\text{C} < T < 125\text{ }^\circ\text{C}$		1		nA

1. See [Section 4.7: Shutdown function on page 17](#).

**Table 6. Electrical characteristics at  $V_{CC+} = 2.7\text{ V}$  with  $V_{CC-} = 0\text{ V}$ ,  $V_{icm} = V_{CC}/2$ ,  $T_{amb} = 25^\circ\text{ C}$ , and  $R_L$  connected to  $V_{CC}/2$  (unless otherwise specified)**

Symbol	Parameter	Conditions	Min.	Typ.	Max.	Unit
<b>DC performance</b>						
$V_{io}$	Input offset voltage	LMV82xA			0.8	mV
		LMV82x			3.5	
		LMV82xA, $-40^\circ\text{ C} < T < 125^\circ\text{ C}$			2	
		LMV82x, $-40^\circ\text{ C} < T < 125^\circ\text{ C}$			4	
$\Delta V_{io}/\Delta T$	Input offset voltage drift <sup>(1)</sup>	$-40^\circ\text{ C} < T < 125^\circ\text{ C}$		1		$\mu\text{V}/^\circ\text{ C}$
$I_{io}$	Input offset current ( $V_{out} = V_{CC}/2$ )			0.5	30	nA
		$-40^\circ\text{ C} < T < 125^\circ\text{ C}$		1	50	
$I_{ib}$	Input bias current ( $V_{out} = V_{CC}/2$ )			60	120	
		$-40^\circ\text{ C} < T < 125^\circ\text{ C}$				
CMR	Common mode rejection ratio $20 \log (\Delta V_{icm}/\Delta V_{io})$ $V_{ic} = 0\text{ V}$ to $V_{CC}-1\text{ V}$ , $V_{out} = V_{CC}/2$		70	75		dB
		$-40^\circ\text{ C} < T < 125^\circ\text{ C}$	68			
$A_{vd}$	Large signal voltage gain $V_{out} = 0.5\text{ V}$ to $(V_{CC}-0.5\text{ V})$	$R_L = 600\ \Omega$	90	100		
		$R_L = 600\ \Omega$ , $-40^\circ\text{ C} < T < 125^\circ\text{ C}$	85			
		$R_L = 2\ \text{k}\Omega$	95	100		
		$R_L = 2\ \text{k}\Omega$ , $-40^\circ\text{ C} < T < 125^\circ\text{ C}$	90			
$V_{CC}-V_{OH}$	High level output voltage	$R_L = 600\ \Omega$			200	mV
		$R_L = 600\ \Omega$ , $-40^\circ\text{ C} < T < 125^\circ\text{ C}$			300	
		$R_L = 2\ \text{k}\Omega$			100	
		$R_L = 2\ \text{k}\Omega$ , $-40^\circ\text{ C} < T < 125^\circ\text{ C}$			200	
$V_{OL}$	Low level output voltage	$R_L = 600\ \Omega$			200	mV
		$R_L = 600\ \Omega$ , $-40^\circ\text{ C} < T < 125^\circ\text{ C}$			300	
		$R_L = 2\ \text{k}\Omega$			120	
		$R_L = 2\ \text{k}\Omega$ , $-40^\circ\text{ C} < T < 125^\circ\text{ C}$			200	
$I_{out}$	$I_{sink}$ ( $V_{out} = V_{CC}$ ) $V_{id} = -1\text{ V}$		15	26		mA
		$-40^\circ\text{ C} < T < 125^\circ\text{ C}$	12			
	$I_{source}$ ( $V_{out} = 0\text{ V}$ ) $V_{id} = 1\text{ V}$		15	21		
		$-40^\circ\text{ C} < T < 125^\circ\text{ C}$	12			
$I_{CC}$	Supply current (per channel) No load, $V_{out} = V_{CC}/2$			220	300	$\mu\text{A}$
		$-40^\circ\text{ C} < T < 125^\circ\text{ C}$			500	

**Table 6. Electrical characteristics at  $V_{CC+} = 2.7\text{ V}$  with  $V_{CC-} = 0\text{ V}$ ,  $V_{icm} = V_{CC}/2$ ,  $T_{amb} = 25^\circ\text{ C}$ , and  $R_L$  connected to  $V_{CC}/2$  (unless otherwise specified) (continued)**

Symbol	Parameter	Conditions	Min.	Typ.	Max.	Unit
<b>AC performance</b>						
GBP	Gain bandwidth product	$R_L > 1\text{ M}\Omega$ , $C_L = 22\text{ pF}$		5.5		MHz
$F_u$	Unity gain frequency			4.5		
$\Phi_m$	Phase margin			60		degrees
$G_m$	Gain margin			10		dB
SR	Slew rate	$R_L > 1\text{ M}\Omega$ , $C_L = 22\text{ pF}$ , $V_{out} = 0.5\text{ V to }V_{CC} - 0.5\text{ V}$	1.2	1.7		V/ $\mu\text{s}$
$e_n$	Equivalent input noise voltage	$f = 1\text{ kHz}$ $f = 10\text{ kHz}$		18 15		$\frac{\text{nV}}{\sqrt{\text{Hz}}}$
$i_n$	Equivalent input noise current	$f = 1\text{ kHz}$		0.30		$\frac{\text{pA}}{\sqrt{\text{Hz}}}$
THD+N	Total harmonic distortion + noise	$f_{in} = 1\text{ kHz}$ , $A_{CL} = 1$ , $R_L = 100\text{ k}\Omega$ $V_{icm} = V_{CC}/2$ , $BW = 22\text{ kHz}$ , $V_{out} = 3\text{ V}_{pp}$		0.001		%

**Table 7. Shutdown characteristics  $V_{CC} = 2.7\text{ V}$**

Symbol	Parameter	Conditions	Min.	Typ.	Max.	Unit
<b>DC performance</b>						
$I_{CC}$	Supply current in shutdown mode (all operators)	$\overline{\text{SHDN}} = V_{CC-}$		2.5	50	nA
		$-40^\circ\text{C} < T < 85^\circ\text{C}$			200	
		$-40^\circ\text{C} < T < 125^\circ\text{C}$				1.5
$t_{on}$	Amplifier turn-on time <sup>(1)</sup>	$R_L = 2\text{ k}\Omega$ , $V_{out} = V_{CC-}\text{ to }V_{CC} - 0.2\text{ V}$		300		ns
$t_{off}$	Amplifier turn-off time <sup>(1)</sup>	$R_L = 2\text{ k}\Omega$ , $V_{out} = V_{CC+} - 1\text{ V to }V_{CC+} - 1.2\text{ V}$		20		
$V_{IH}$	$\overline{\text{SHDN}}$ logic high		$V_{CC-}$ 0.5			V
$V_{IL}$	$\overline{\text{SHDN}}$ logic low				0.5	
$I_{IH}$	$\overline{\text{SHDN}}$ current high	$\overline{\text{SHDN}} = V_{CC+}$		10		pA
$I_{IL}$	$\overline{\text{SHDN}}$ current low	$\overline{\text{SHDN}} = V_{CC-}$		10		
$I_{OLeak}$	Output leakage in shutdown mode	$\overline{\text{SHDN}} = V_{CC-}$		50		
		$-40^\circ\text{C} < T < 125^\circ\text{C}$		1		nA

1. See [Section 4.7: Shutdown function on page 17](#).

**Table 8. Electrical characteristics at  $V_{CC+} = 5\text{ V}$  with  $V_{CC-} = 0\text{ V}$ ,  $V_{icm} = V_{CC}/2$ ,  $T_{amb} = 25^\circ\text{ C}$ , and  $R_L$  connected to  $V_{CC}/2$  (unless otherwise specified)**

Symbol	Parameter	Conditions	Min.	Typ.	Max.	Unit
<b>DC performance</b>						
$V_{io}$	Input offset voltage	LMV82xA			0.8	mV
		LMV82x			3.5	
		LMV82xA, $-40^\circ\text{ C} < T < 125^\circ\text{ C}$			2	
		LMV82x, $-40^\circ\text{ C} < T < 125^\circ\text{ C}$			4	
$\Delta V_{io}/\Delta T$	Input offset voltage drift <sup>(1)</sup>	$-40^\circ\text{ C} < T < 125^\circ\text{ C}$		1		$\mu\text{V}/^\circ\text{ C}$
$I_{io}$	Input offset current ( $V_{out} = V_{CC}/2$ )			0.5	30	nA
		$-40^\circ\text{ C} < T < 125^\circ\text{ C}$		1	50	
$I_{ib}$	Input bias current ( $V_{out} = V_{CC}/2$ )			60	120	nA
		$-40^\circ\text{ C} < T < 125^\circ\text{ C}$			180	
CMR	Common mode rejection ratio 20 $\log(\Delta V_{icm}/\Delta V_{io})$ $V_{ic} = 0\text{ V}$ to $V_{CC}-1\text{ V}$ , $V_{out} = V_{CC}/2$		72	90		dB
		$-40^\circ\text{ C} < T < 125^\circ\text{ C}$	70			
SVR	Supply voltage rejection ratio 20 $\log(\Delta V_{CC}/\Delta V_{io})$	$V_{CC} = 2.5$ to $5\text{ V}$				dB
			70	75		
		$-40^\circ\text{ C} < T < 125^\circ\text{ C}$	65			
$A_{vd}$	Large signal voltage gain $V_{out} = 0.5\text{ V}$ to $(V_{CC}-0.5\text{ V})$	$R_L = 600\ \Omega$	95	100		dB
		$R_L = 600\ \Omega$ , $-40^\circ\text{ C} < T < 125^\circ\text{ C}$	90			
		$R_L = 2\text{ k}\Omega$	95	100		
		$R_L = 2\text{ k}\Omega$ , $-40^\circ\text{ C} < T < 125^\circ\text{ C}$	90			
$V_{CC}-V_{OH}$	High level output voltage	$R_L = 600\ \Omega$			250	mV
		$R_L = 600\ \Omega$ , $-40^\circ\text{ C} < T < 125^\circ\text{ C}$			400	
		$R_L = 2\text{ k}\Omega$			150	
		$R_L = 2\text{ k}\Omega$ , $-40^\circ\text{ C} < T < 125^\circ\text{ C}$			200	
$V_{OL}$	Low level output voltage	$R_L = 600\ \Omega$			250	mV
		$R_L = 600\ \Omega$ , $-40^\circ\text{ C} < T < 125^\circ\text{ C}$			300	
		$R_L = 2\text{ k}\Omega$			150	
		$R_L = 2\text{ k}\Omega$ , $-40^\circ\text{ C} < T < 125^\circ\text{ C}$			200	
$I_{out}$	$I_{sink}$ ( $V_{out} = V_{CC}$ ) $V_{id} = -1\text{ V}$		35	43		mA
		$-40^\circ\text{ C} < T < 125^\circ\text{ C}$	25			
	$I_{source}$ ( $V_{out} = 0\text{ V}$ ) $V_{id} = 1\text{ V}$		60	70		
		$-40^\circ\text{ C} < T < 125^\circ\text{ C}$	50			
$I_{CC}$	Supply current (per channel) No load, $V_{out} = V_{CC}/2$			300	400	$\mu\text{ A}$
		$-40^\circ\text{ C} < T < 125^\circ\text{ C}$			600	

**Table 8. Electrical characteristics at  $V_{CC+} = 5\text{ V}$  with  $V_{CC-} = 0\text{ V}$ ,  $V_{icm} = V_{CC-}/2$ ,  $T_{amb} = 25^\circ\text{ C}$ , and  $R_L$  connected to  $V_{CC-}/2$  (unless otherwise specified) (continued)**

Symbol	Parameter	Conditions	Min.	Typ.	Max.	Unit
<b>AC performance</b>						
GBP	Gain bandwidth product	$R_L > 1\text{ M}\Omega$ , $C_L = 22\text{ pF}$		5.5		MHz
$F_u$	Unity gain frequency			4.5		
$\Phi_m$	Phase margin			60		degrees
$G_m$	Gain margin			10		dB
SR	Slew rate	$R_L > 1\text{ M}\Omega$ , $C_L = 22\text{ pF}$ , $V_{out} = 0.5\text{ V}$ to $V_{CC-} - 0.5\text{ V}$	1.4	1.9		V/ $\mu\text{s}$
$e_n$	Equivalent input noise voltage	$f = 1\text{ kHz}$ $f = 10\text{ kHz}$		16 13		$\frac{\text{nV}}{\sqrt{\text{Hz}}}$
$i_n$	Equivalent input noise current	$f = 1\text{ kHz}$		0.30		$\frac{\text{pA}}{\sqrt{\text{Hz}}}$
THD+N	Total harmonic distortion + noise	$f_{in} = 1\text{ kHz}$ , $A_{CL} = 1$ , $R_L = 100\text{ k}\Omega$ , $V_{icm} = V_{CC-}/2$ , $BW = 22\text{ kHz}$ , $V_{out} = 3\text{ Vpp}$		0.001		%

1. See [Section 4.4: Input offset voltage drift over temperature](#).

**Table 9. Shutdown characteristics  $V_{CC} = 5\text{ V}$**

Symbol	Parameter	Conditions	Min.	Typ.	Max.	Unit
<b>DC performance</b>						
$I_{CC}$	Supply current in shutdown mode (all operators) $\overline{\text{SHDN}} = V_{CC-}$	$T = 25^\circ\text{C}$		2.5	50	nA
		$-40^\circ\text{C} < T < 85^\circ\text{C}$			200	
		$-40^\circ\text{C} < T < 125^\circ\text{C}$				1.5
$t_{on}$	Amplifier turn-on time <sup>(1)</sup>	$R_L = 2\text{ k}\Omega$ , $V_{out} = V_{CC-}$ to $V_{CC+} + 0.2\text{ V}$		300		ns
$t_{off}$	Amplifier turn-off time <sup>(1)</sup>	$R_L = 2\text{ k}\Omega$ , $V_{out} = V_{CC+} - 1\text{ V}$ to $V_{CC+} - 1.2\text{ V}$		20		
$V_{IH}$	$\overline{\text{SHDN}}$ logic high		$V_{CC-}$ 0.5			V
$V_{IL}$	$\overline{\text{SHDN}}$ logic low				0.5	
$I_{IH}$	$\overline{\text{SHDN}}$ current high	$\overline{\text{SHDN}} = V_{CC+}$		10		pA
$I_{IL}$	$\overline{\text{SHDN}}$ current low	$\overline{\text{SHDN}} = V_{CC-}$		10		
$I_{OLeak}$	Output leakage in shutdown mode	$\overline{\text{SHDN}} = V_{CC-}$		50		
		$-40^\circ\text{C} < T < 125^\circ\text{C}$		1		nA

1. See [Section 4.7: Shutdown function on page 17](#).

Figure 2. Supply current vs. supply voltage at  $V_{icm} = V_{CC}/2$

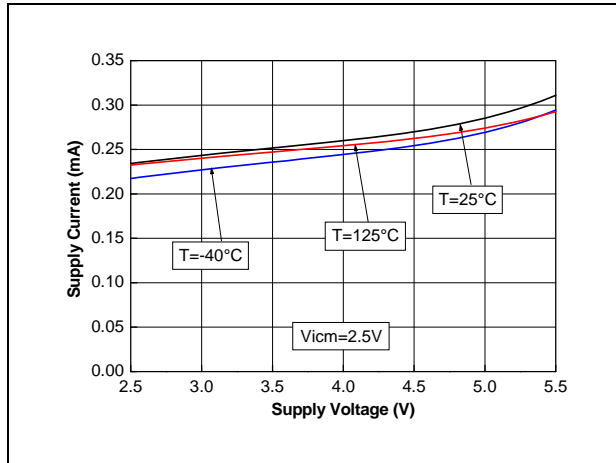

Figure 3. Supply current vs.  $V_{icm}$  at  $V_{CC} = 5V$

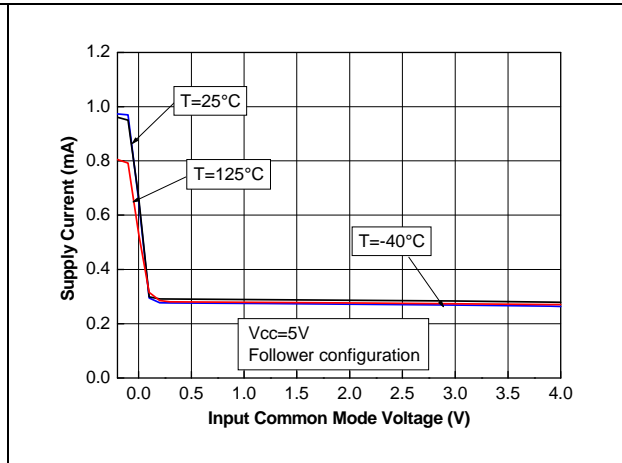

Figure 4.  $V_{io}$  distribution at  $V_{CC} = 5V$

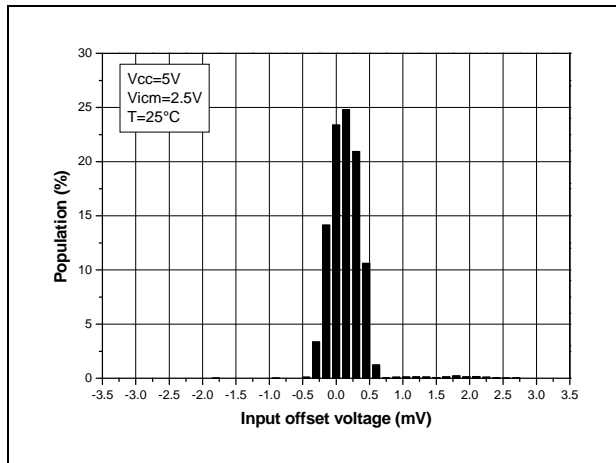

Figure 5. Input offset voltage vs. input common mode voltage at  $V_{CC} = 5V$

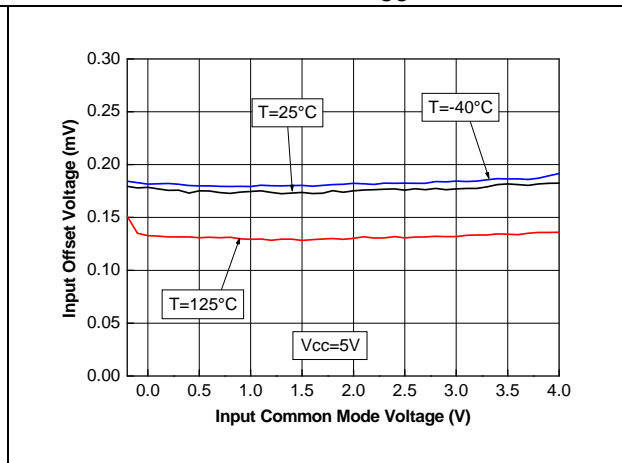

Figure 6. Output current vs. output voltage at  $V_{CC} = 2.7V$

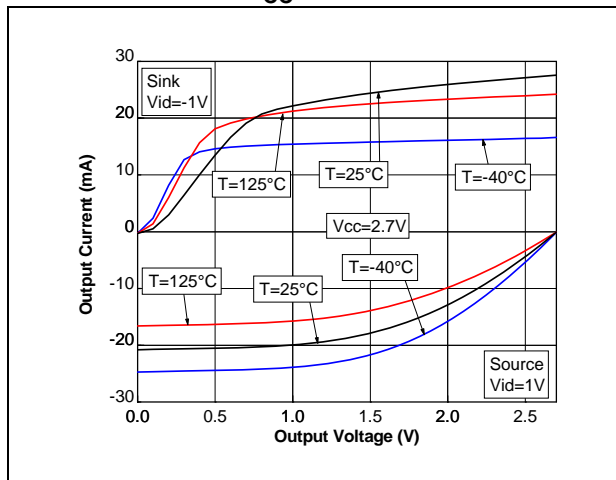

Figure 7. Output current vs. output voltage at  $V_{CC} = 5V$

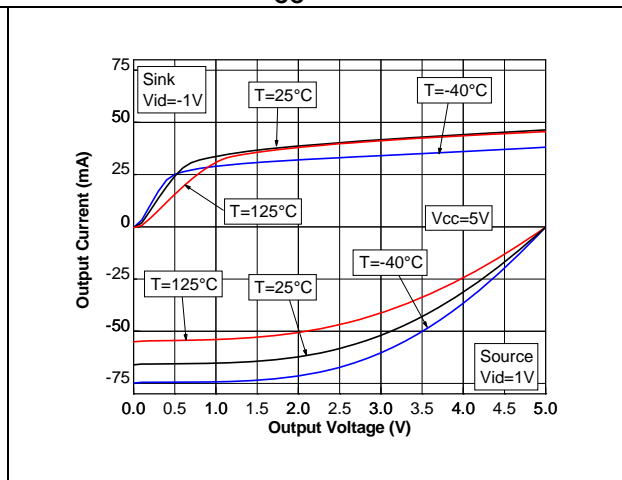

Figure 8. Output current vs. supply voltage at  $V_{icm} = V_{CC}/2$

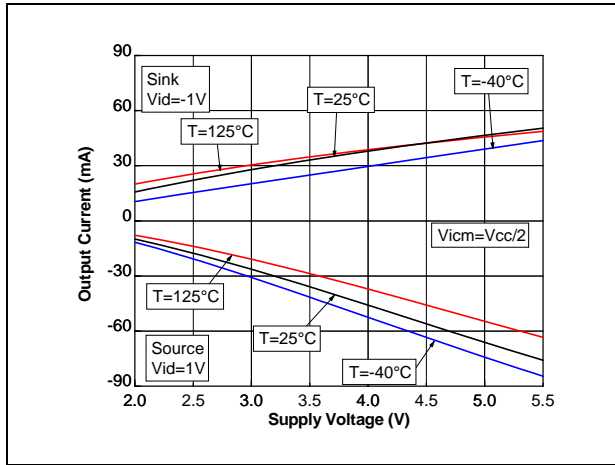

Figure 9. Voltage gain and phase with  $C_L = 40 \text{ pF}$

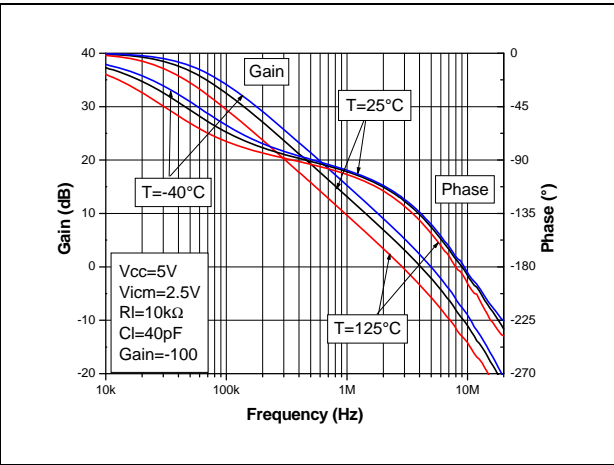

Figure 10. Voltage gain and phase with  $C_L = 100 \text{ pF}$

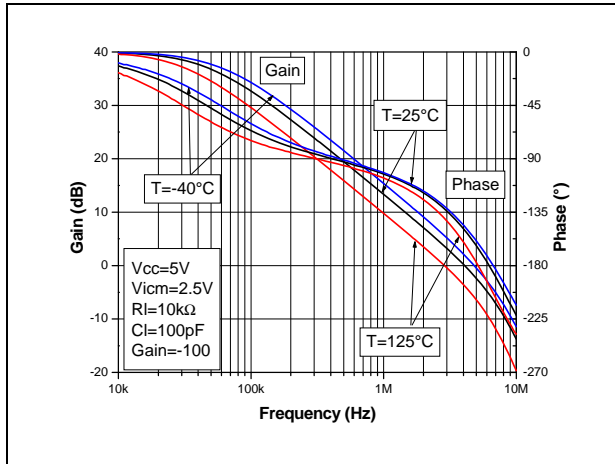

Figure 11. Voltage gain and phase with  $C_L = 200 \text{ pF}$

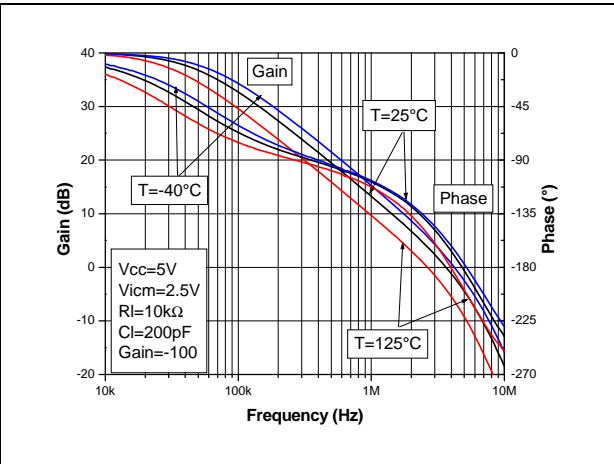

Figure 12. Phase margin vs. output current at  $V_{CC} = 5 \text{ V}$

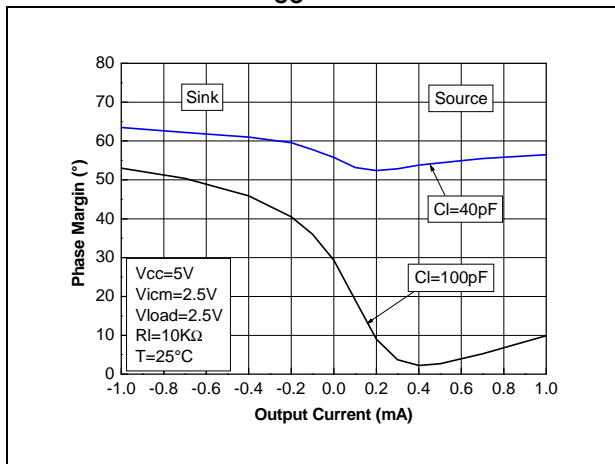

Figure 13. Stability in follower configuration

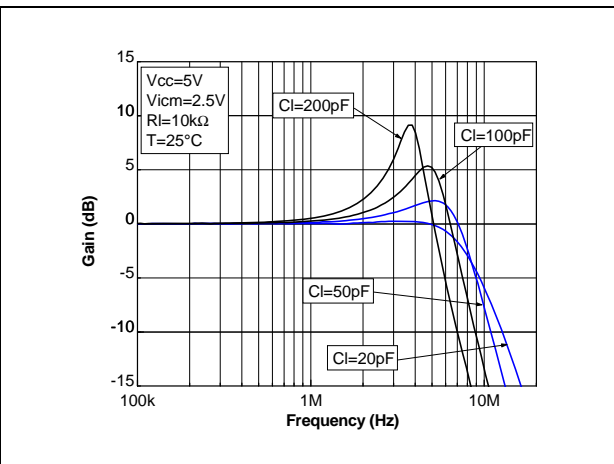

Figure 14. Positive and negative slew rate vs. supply voltage

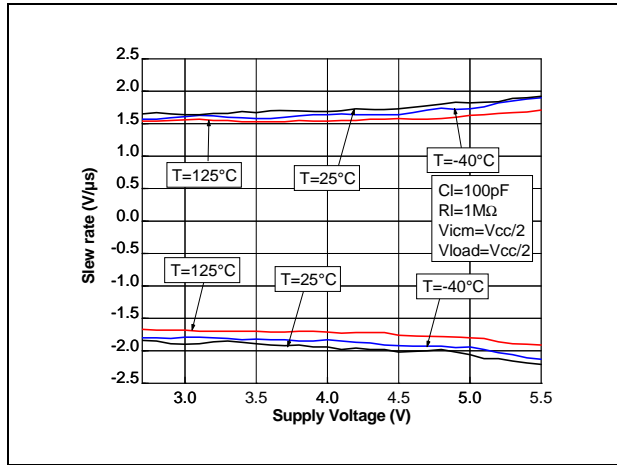

Figure 15. Positive slew rate at V<sub>CC</sub> = 5 V with C<sub>L</sub> = 100 pF

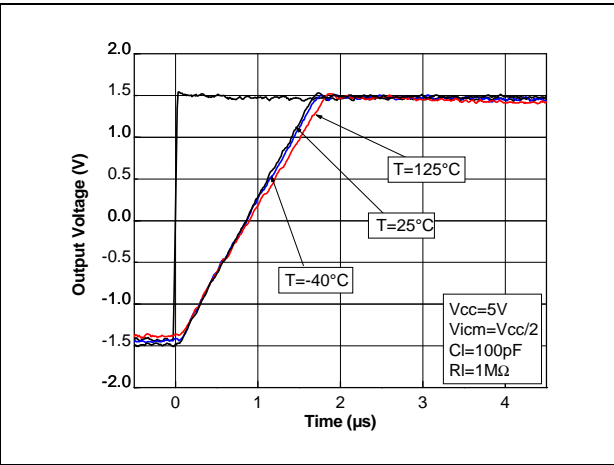

Figure 16. Negative slew rate at V<sub>CC</sub> = 5 V with C<sub>L</sub> = 100 pF

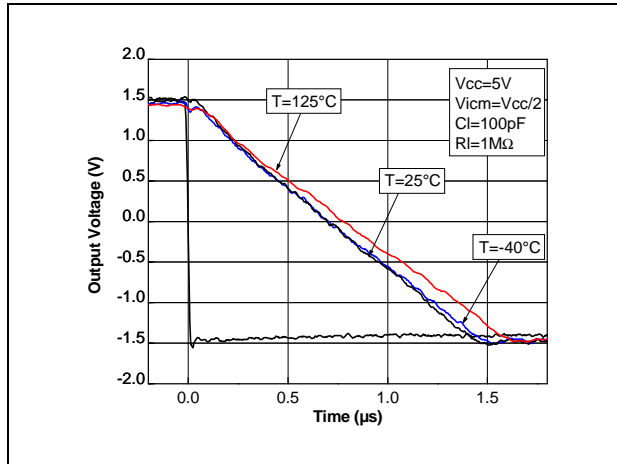

Figure 17. Noise vs. frequency at V<sub>CC</sub> = 5 V

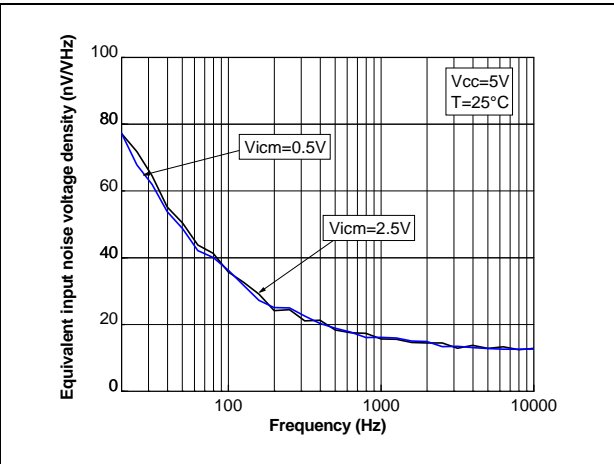

Figure 18. 0.1 Hz to 10 Hz noise at V<sub>CC</sub> = 5 V

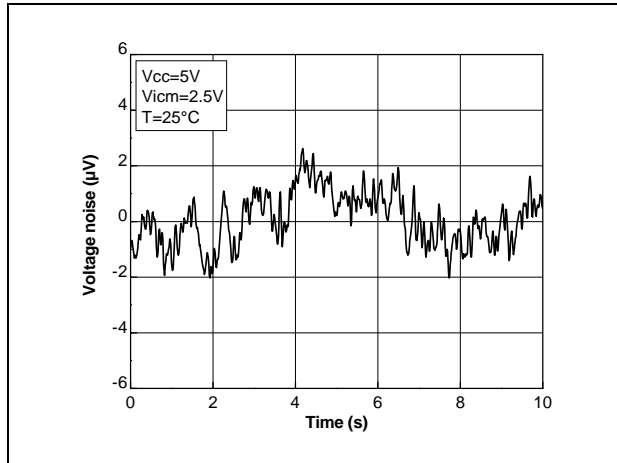

Figure 19. Distortion + noise vs. frequency

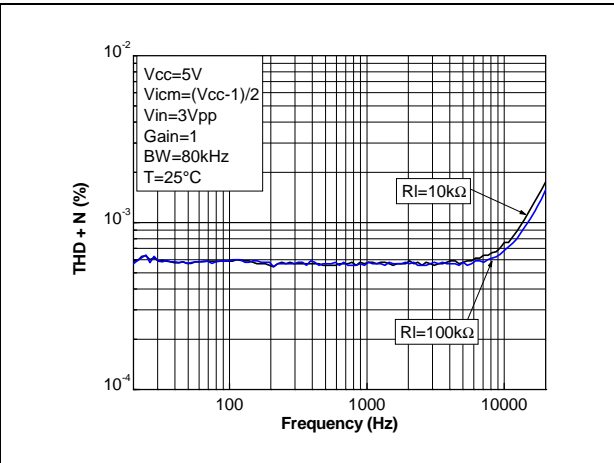
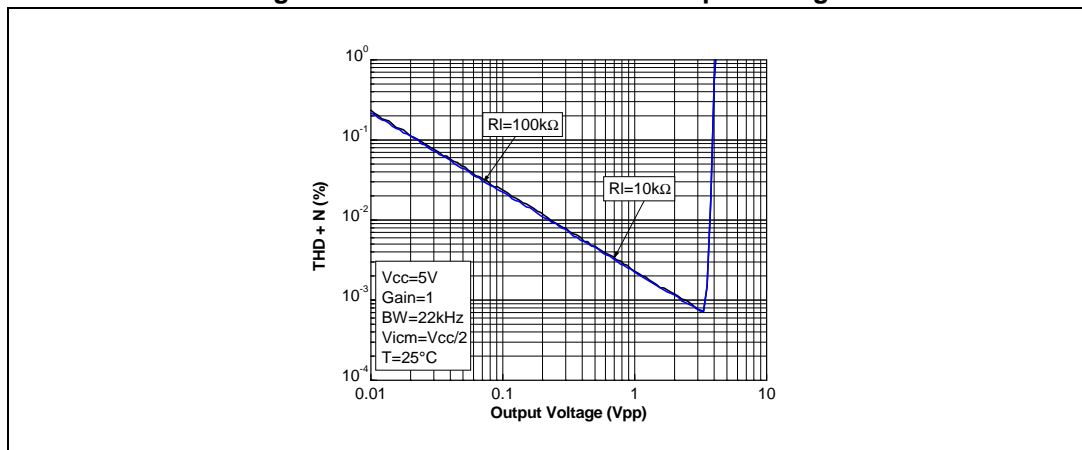

Figure 20. Distortion + noise vs. output voltage



## 4 Application information

### 4.1 Operating voltages

The LMV82x and LMV82xA can operate from 2.5 to 5.5 V. The devices' parameters are fully specified for 2.5, 2.7, and 5 V power supplies. Additionally, the main specifications are guaranteed at extended temperature ranges from -40° C to +125° C.

### 4.2 Input common mode range

The LMV82x and LMV82xA devices have an input common mode range that includes ground. The input common mode range is extended from  $V_{CC-} - 0.2$  V to  $V_{CC+} - 1$  V, with no output phase reversal.

### 4.3 Rail-to-rail output

The operational amplifiers' output levels can go close to the rails: 150 mV maximum above and below the rail when connected to a 2 k $\Omega$  resistive load to  $V_{CC}/2$ .

### 4.4 Input offset voltage drift over temperature

The maximum input voltage drift over temperature variation is defined in [Equation 1](#).

#### Equation 1

$$\frac{\Delta V_{io}}{\Delta T} = \max \left| \frac{V_{io}(T) - V_{io}(25^{\circ}\text{C})}{T - 25^{\circ}\text{C}} \right|$$

for  $T_{\min} < T < T_{\max}$ .

### 4.5 PCB layouts

For correct operation, it is advised to add 10 nF decoupling capacitors as close as possible to the power supply pins.

### 4.6 Macromodel

Accurate macromodels of the LMV82x and LMV82xA are available on STMicroelectronics' web site at [www.st.com](http://www.st.com). These models are a trade-off between accuracy and complexity (that is, time simulation) of the LMV82x and LMV82xA operational amplifiers. They emulate the nominal performances of a typical device within the specified operating conditions mentioned in the datasheet. They also help to validate a design approach and to select the right operational amplifier, *but they do not replace on-board measurements*.

### 4.7 Shutdown function

The operational amplifier is enabled when the  $\overline{\text{SHDN}}$  pin is pulled high. To disable the amplifier, the SHDN pin must be pulled down to  $V_{CC-}$ . When in shutdown mode, the amplifier output is in a high impedance state. The SHDN pin must never be left floating but tied to  $V_{CC+}$  or  $V_{CC-}$ .

The turn-on and turn-off times are calculated for an output variation of  $\pm 200$  mV. *Figure 21* and *Figure 22* show the test configurations. *Figure 23* and *Figure 24* show the respective results with these test configurations.

**Figure 21. Test configuration for turn-on time (Vout pulled down)**

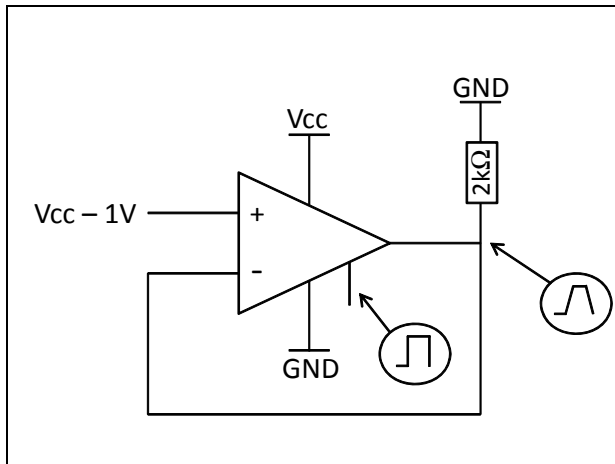

**Figure 22. Test configuration for turn-off time (Vout pulled down)**

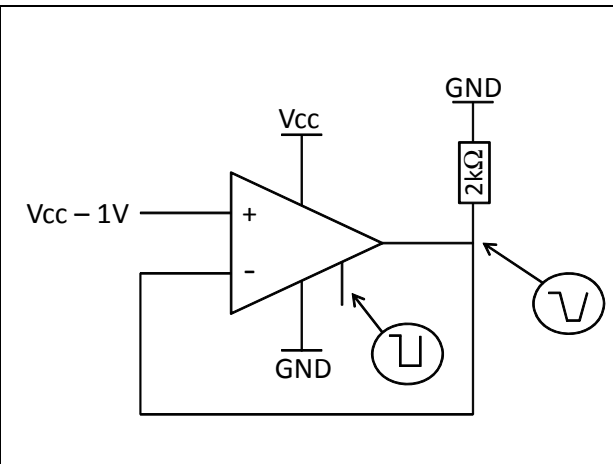

**Figure 23. Turn-on time,  $V_{CC} = 5$  V, Vout pulled down,  $T = 25$  °C**

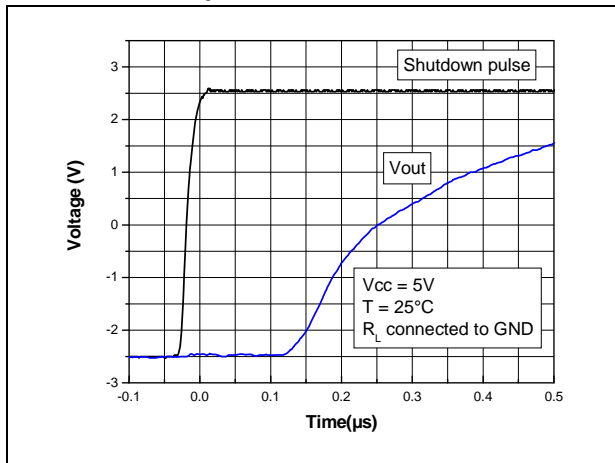

**Figure 24. Turn-off time,  $V_{CC} = 5$  V, Vout pulled down,  $T = 25$  °C**

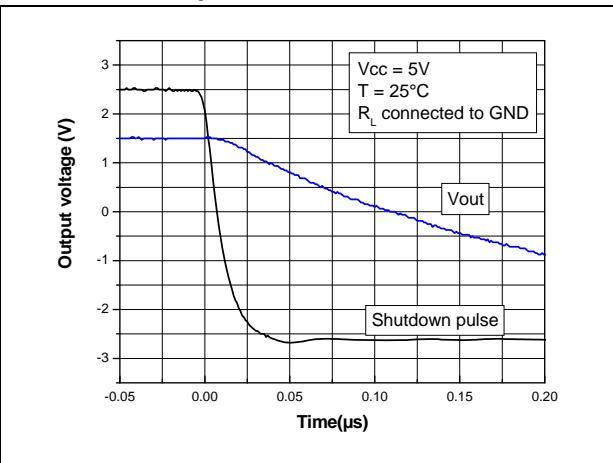

## 5 Package information

In order to meet environmental requirements, ST offers these devices in different grades of ECOPACK<sup>®</sup> packages, depending on their level of environmental compliance. ECOPACK<sup>®</sup> specifications, grade definitions and product status are available at: [www.st.com](http://www.st.com). ECOPACK<sup>®</sup> is an ST trademark.

### 5.1 SC70-5 (or SOT323-5) package information

Figure 25. SC70-5 (or SOT323-5) package mechanical drawing

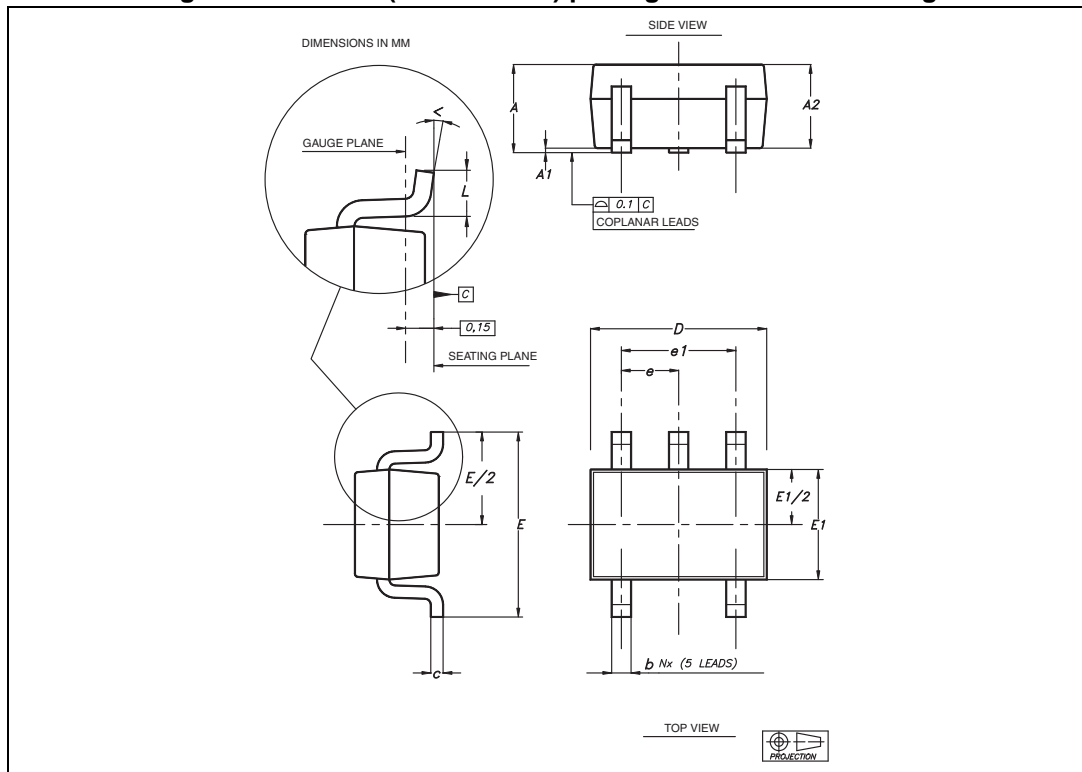

Table 10. SC70-5 (or SOT323-5) package mechanical data

Ref	Dimensions					
	Millimeters			Inches		
	Min	Typ	Max	Min	Typ	Max
A	0.80		1.10	0.032		0.043
A1			0.10			0.004
A2	0.80	0.90	1.00	0.032	0.035	0.039
b	0.15		0.30	0.006		0.012
c	0.10		0.22	0.004		0.009
D	1.80	2.00	2.20	0.071	0.079	0.087
E	1.80	2.10	2.40	0.071	0.083	0.094
E1	1.15	1.25	1.35	0.045	0.049	0.053
e		0.65			0.025	
e1		1.30			0.051	
L	0.26	0.36	0.46	0.010	0.014	0.018
<	0 °		8 °	0 °		8 °

## 5.2 SOT23-5 package information

Figure 26. SOT23-5 package mechanical drawing

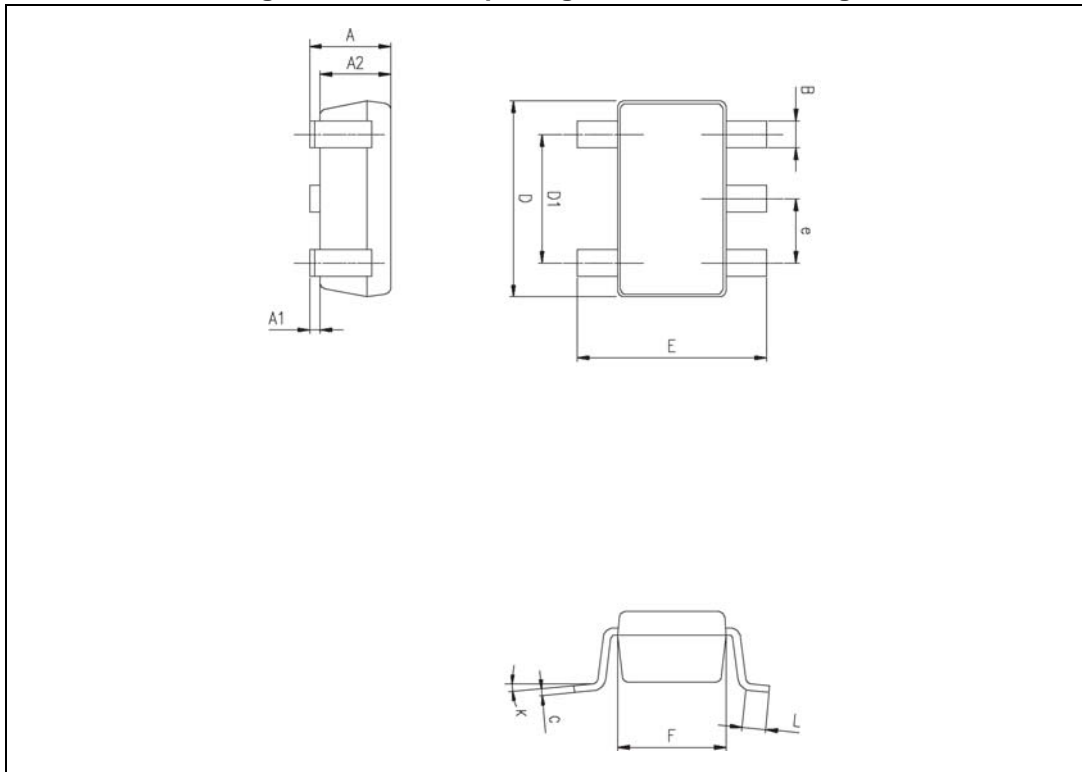

Table 11. SOT23-5 package mechanical data

Ref.	Dimensions					
	Millimeters			Inches		
	Min.	Typ.	Max.	Min.	Typ.	Max.
A	0.90	1.20	1.45	0.035	0.047	0.057
A1			0.15			0.006
A2	0.90	1.05	1.30	0.035	0.041	0.051
B	0.35	0.40	0.50	0.013	0.015	0.019
C	0.09	0.15	0.20	0.003	0.006	0.008
D	2.80	2.90	3.00	0.110	0.114	0.118
D1		1.90			0.075	
e		0.95			0.037	
E	2.60	2.80	3.00	0.102	0.110	0.118
F	1.50	1.60	1.75	0.059	0.063	0.069
L	0.10	0.35	0.60	0.004	0.013	0.023
K	0 °		10 °	0 °		10 °

### 5.3 SOT23-6 package information

Figure 27. SOT23-6 package mechanical drawing

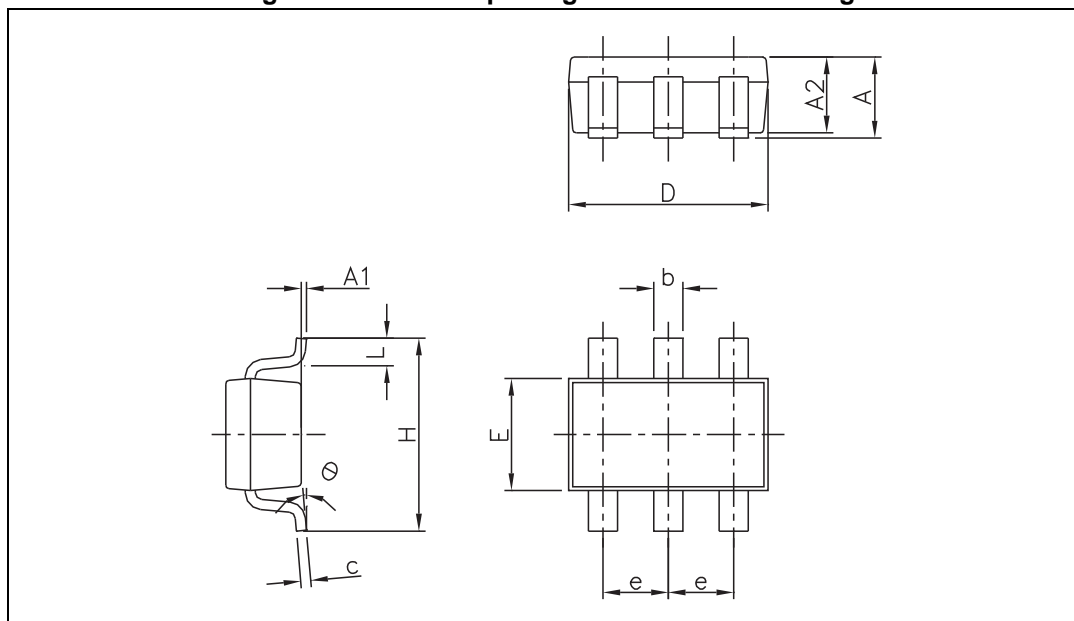

Table 12. SOT23-6 package mechanical data

Ref.	Dimensions					
	Millimeters			Inches		
	Min.	Typ.	Max.	Min.	Typ.	Max.
A	0.90		1.45	0.035		0.057
A1			0.10			0.004
A2	0.90		1.30	0.035		0.051
b	0.35		0.50	0.013		0.019
c	0.09		0.20	0.003		0.008
D	2.80		3.05	0.110		0.120
E	1.50		1.75	0.060		0.069
e		0.95			0.037	
H	2.60		3.00	0.102		0.118
L	0.10		0.60	0.004		0.024
θ	0 °		10 °	0 °		10 °

### 5.4 DFN8 2 x 2 mm package information

Figure 28. DFN8 2 x 2 mm package mechanical drawing (pitch 0.5 mm)

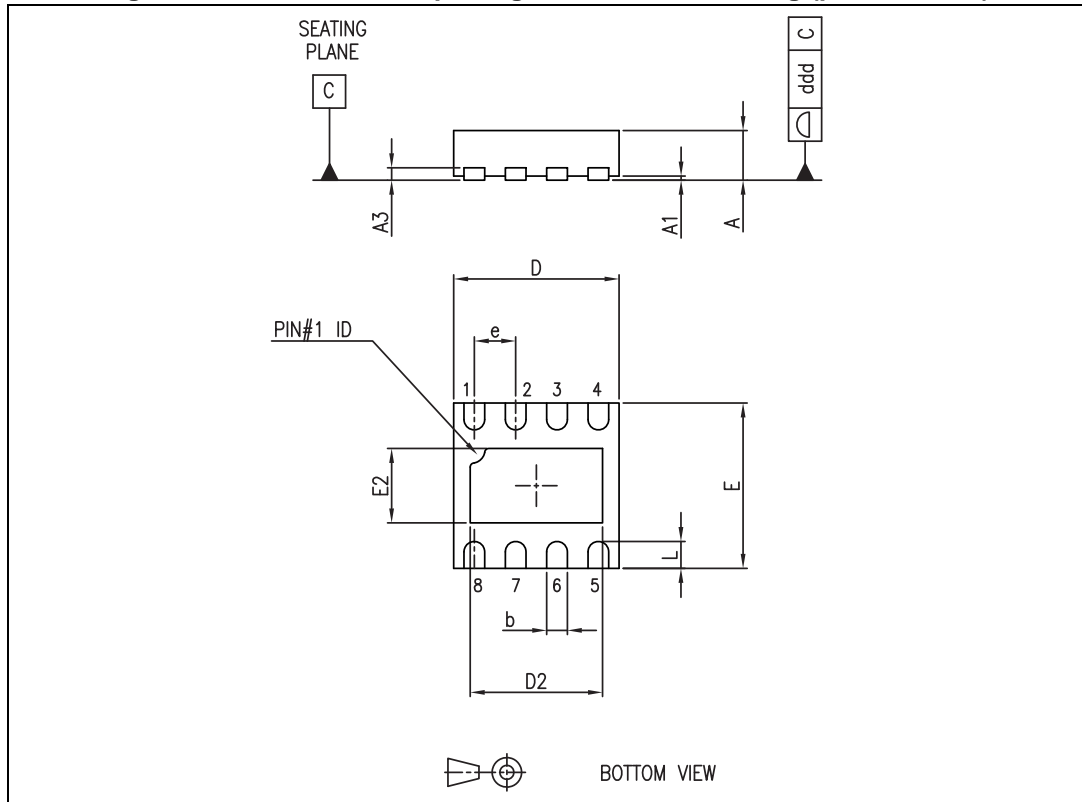

Table 13. DFN8 2 x 2 mm package mechanical data (pitch 0.5 mm)

Ref.	Dimensions					
	Millimeters			Inches		
	Min.	Typ.	Max.	Min.	Typ.	Max.
A	0.51	0.55	0.60	0.020	0.022	0.024
A1			0.05			0.002
A3		0.15			0.006	
b	0.18	0.25	0.30	0.007	0.010	0.012
D	1.85	2.00	2.15	0.073	0.079	0.085
D2	1.45	1.60	1.70	0.057	0.063	0.067
E	1.85	2.00	2.15	0.073	0.079	0.085
E2	0.75	0.90	1.00	0.030	0.035	0.040
e		0.50			0.020	
L			0.425			0.017
ddd			0.08			0.003

### 5.5 MiniSO-8 package information

Figure 29. MiniSO-8 package mechanical drawing

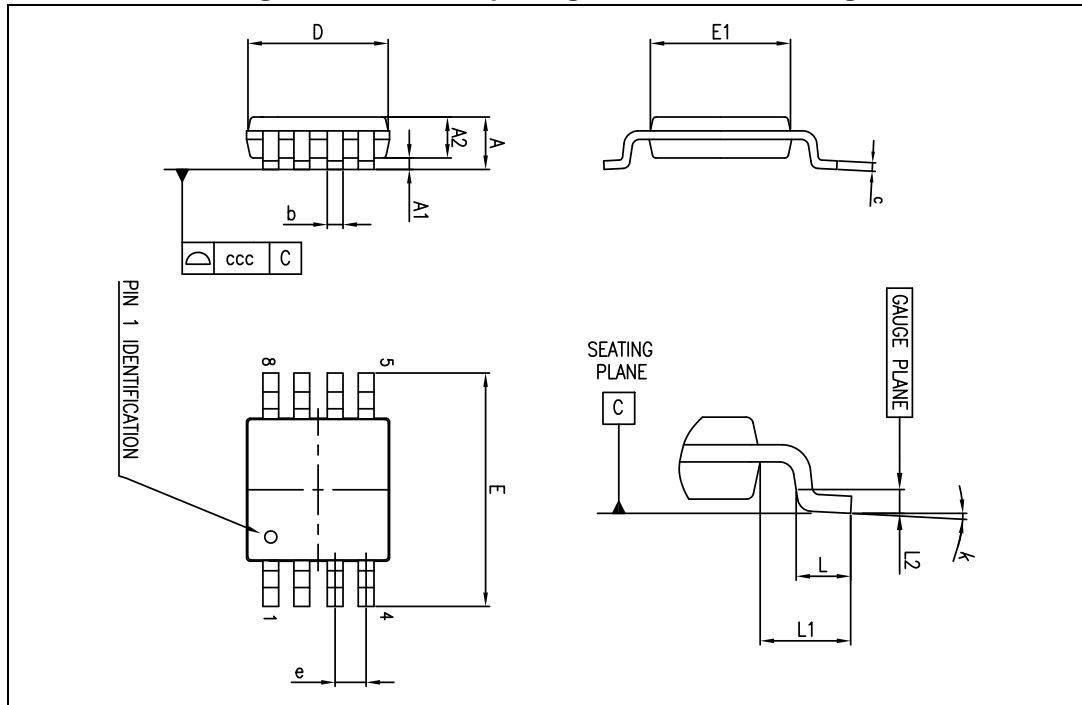

Table 14. MiniSO-8 package mechanical data

Ref.	Dimensions					
	Millimeters			Inches		
	Min.	Typ.	Max.	Min.	Typ.	Max.
A			1.1			0.043
A1	0		0.15	0		0.006
A2	0.75	0.85	0.95	0.030	0.033	0.037
b	0.22		0.40	0.009		0.016
c	0.08		0.23	0.003		0.009
D	2.80	3.00	3.20	0.11	0.118	0.126
E	4.65	4.90	5.15	0.183	0.193	0.203
E1	2.80	3.00	3.10	0.11	0.118	0.122
e		0.65			0.026	
L	0.40	0.60	0.80	0.016	0.024	0.031
L1		0.95			0.037	
L2		0.25			0.010	
k	0°		8°	0°		8°
ccc			0.10			0.004

### 5.6 MiniSO-10 package information

Figure 30. MiniSO-10 package mechanical drawing

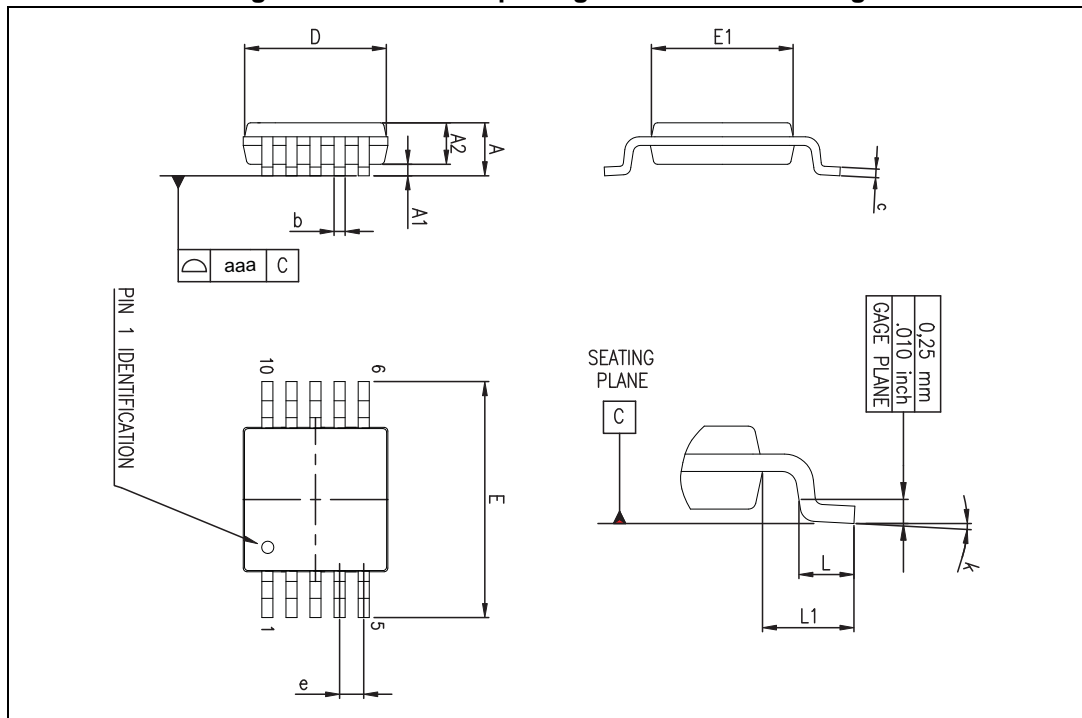

Table 15. MiniSO-10 package mechanical data

Ref.	Dimensions					
	Millimeters			Inches		
	Min.	Typ.	Max.	Min.	Typ.	Max.
A			1.10			0.043
A1	0.05	0.10	0.15	0.002	0.004	0.006
A2	0.78	0.86	0.94	0.031	0.034	0.037
b	0.25	0.33	0.40	0.010	0.013	0.016
c	0.15	0.23	0.30	0.006	0.009	0.012
D	2.90	3.00	3.10	0.114	0.118	0.122
E	4.75	4.90	5.05	0.187	0.193	0.199
E1	2.90	3.00	3.10	0.114	0.118	0.122
e		0.50			0.020	
L	0.40	0.55	0.70	0.016	0.022	0.028
L1		0.95			0.037	
k	0°	3°	6°	0°	3°	6°
aaa			0.10			0.004

### 5.7 TSSOP14 package information

Figure 31. TSSOP14 package mechanical drawing

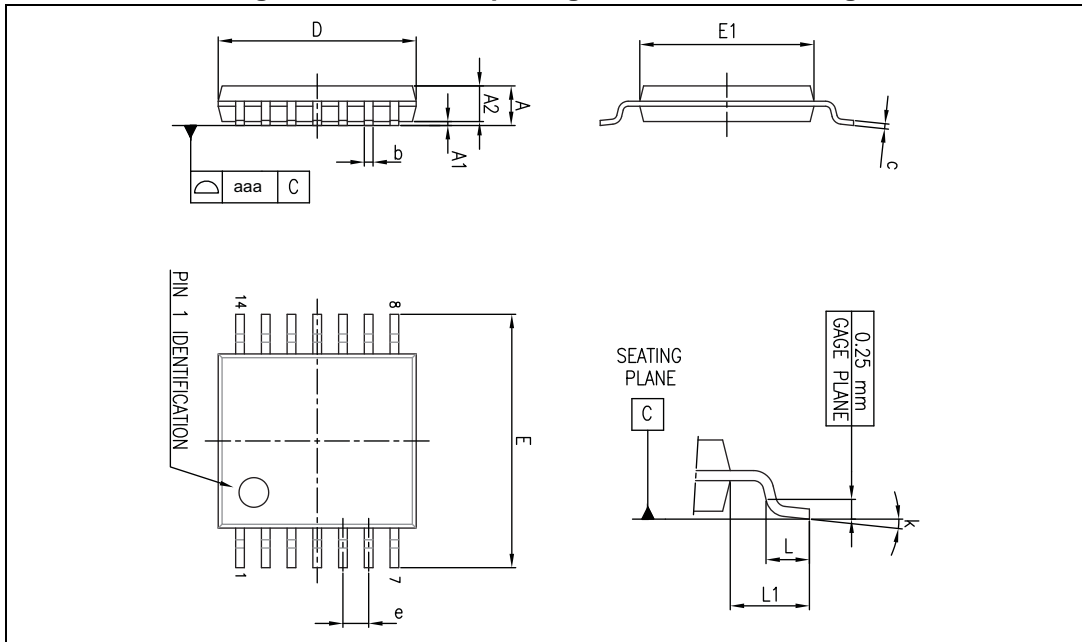

Table 16. TSSOP14 package mechanical data

Ref.	Dimensions					
	Millimeters			Inches		
	Min.	Typ.	Max.	Min.	Typ.	Max.
A			1.20			0.047
A1	0.05		0.15	0.002	0.004	0.006
A2	0.80	1.00	1.05	0.031	0.039	0.041
b	0.19		0.30	0.007		0.012
c	0.09		0.20	0.004		0.0089
D	4.90	5.00	5.10	0.193	0.197	0.201
E	6.20	6.40	6.60	0.244	0.252	0.260
E1	4.30	4.40	4.50	0.169	0.173	0.176
e		0.65			0.0256	
L	0.45	0.60	0.75	0.018	0.024	0.030
L1		1.00			0.039	
k	0°		8°	0°		8°
aaa			0.10			0.004

### 5.8 TSSOP16 package information

Figure 32. TSSOP16 package mechanical drawing

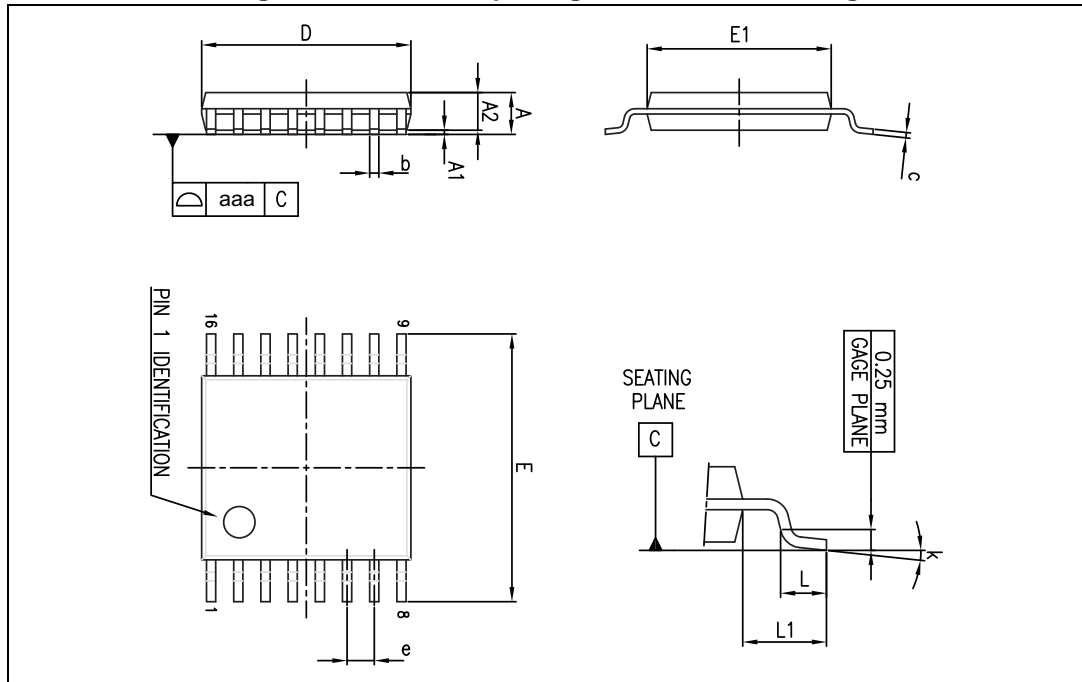

Table 17. TSSOP16 package mechanical data

Ref.	Dimensions					
	Millimeters			Inches		
	Min.	Typ.	Max.	Min.	Typ.	Max.
A			1.20			0.047
A1	0.05		0.15	0.002		0.006
A2	0.80	1.00	1.05	0.031	0.039	0.041
b	0.19		0.30	0.007		0.012
c	0.09		0.20	0.004		0.008
D	4.90	5.00	5.10	0.193	0.197	0.201
E	6.20	6.40	6.60	0.244	0.252	0.260
E1	4.30	4.40	4.50	0.169	0.173	0.177
e		0.65			0.0256	
k	0 °		8 °	0 °		8 °
L	0.45	0.60	0.75	0.018	0.024	0.030
L1		1.00			0.039	
aaa			0.10			0.004

### 5.9 SO-8 package information

Figure 33. SO-8 package mechanical drawing

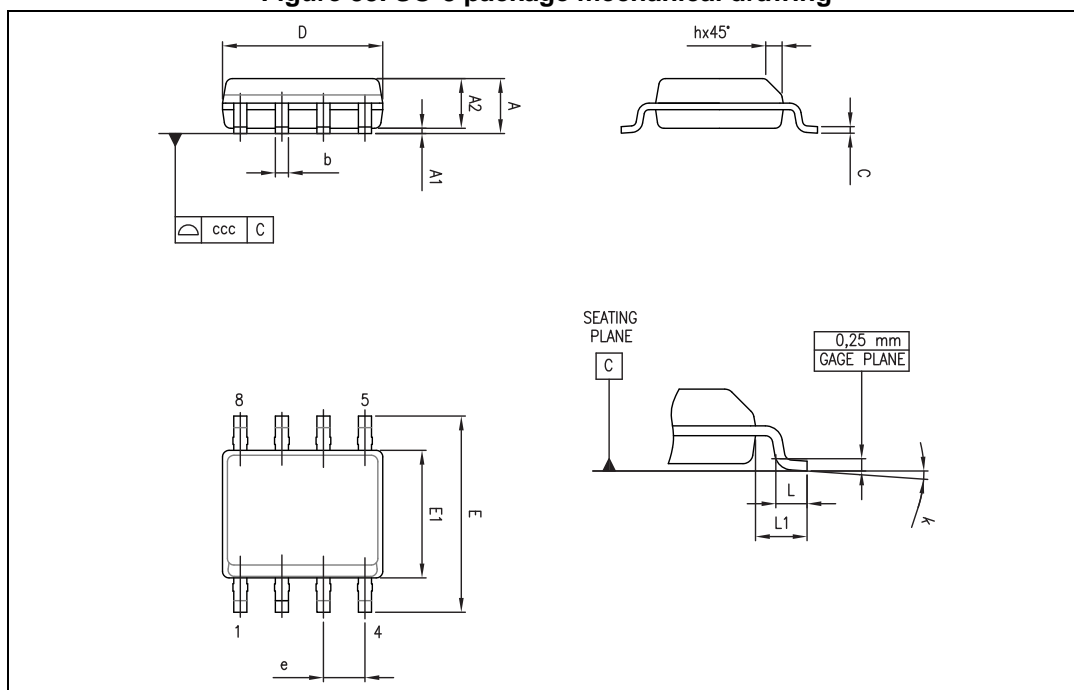

Table 18. SO-8 package mechanical data

Ref.	Dimensions					
	Millimeters			Inches		
	Min.	Typ.	Max.	Min.	Typ.	Max.
A			1.75			0.069
A1	0.10		0.25	0.004		0.010
A2	1.25			0.049		
b	0.28		0.48	0.011		0.019
c	0.17		0.23	0.007		0.010
D	4.80	4.90	5.00	0.189	0.193	0.197
E	5.80	6.00	6.20	0.228	0.236	0.244
E1	3.80	3.90	4.00	0.150	0.154	0.157
e		1.27			0.050	
h	0.25		0.50	0.010		0.020
L	0.40		1.27	0.016		0.050
L1		1.04			0.040	
k	1 °		8 °	1 °		8 °
ccc			0.10			0.004

### 5.10 SO-14 package information

Figure 34. SO-14 package mechanical drawing

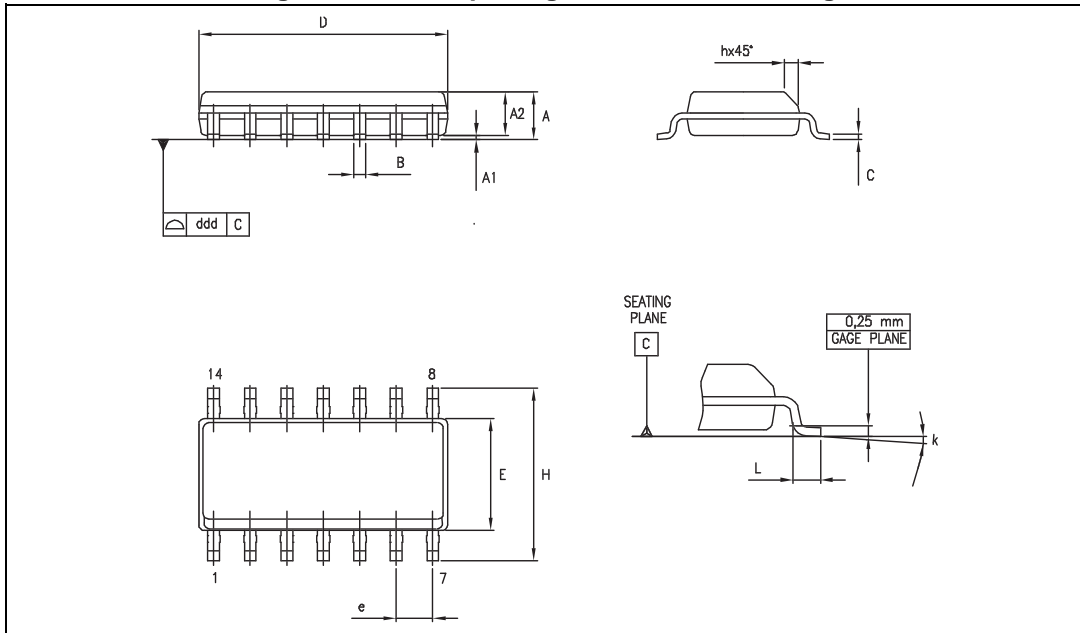

Table 19. SO-14 package mechanical data

Dimensions						
Ref.	Millimeters			Inches		
	Min.	Typ.	Max.	Min.	Typ.	Max.
A	1.35		1.75	0.05		0.068
A1	0.10		0.25	0.004		0.009
A2	1.10		1.65	0.04		0.06
B	0.33		0.51	0.01		0.02
C	0.19		0.25	0.007		0.009
D	8.55		8.75	0.33		0.34
E	3.80		4.0	0.15		0.15
e		1.27			0.05	
H	5.80		6.20	0.22		0.24
h	0.25		0.50	0.009		0.02
L	0.40		1.27	0.015		0.05
k	8° (max.)					
ddd			0.10			0.004

## 6 Ordering information

**Table 20. Order codes**

Order code	Temperature range	Package	Packing	Marking
LMV821ICT	-40 °C to +125 °C	SC70-5	Tape & reel	K1S
LMV821ILT		SOT23-5		K155
LMV822IQ2T		DFN8 2x2		K1S
LMV822IST		MiniSO8		K155
LMV822IDT		SO8		LMV822I
LMV824IPT		TSSOP14		LMV824I
LMV824IDT		SO14		LMV824I
LMV821AICT	-40 °C to +125 °C	SC70-5	Tape & reel	K1T
LMV821AILT		SOT23-5		K156
LMV822AIST		MiniSO8		K156
LMV822AIDT		SO8		LMV822AI
LMV824AIPT		TSSOP14		LMV824AI
LMV824AIDT		SO14		LMV824AI

**Table 21. Order codes (with shutdown pin)**

Order code	Temperature range	Package	Packing	Marking
LMV820ILT	-40 °C to +125 °C	SOT23-6	Tape & reel	K155
LMV823IST		MiniSO10		K155
LMV825IPT		TSSOP16		LMV825I
LMV820AILT	-40 °C to +125 °C	SOT23-6	Tape & reel	K156
LMV823AIST		MiniSO10		K156
LMV825AIPT		TSSOP16		LMV825AI

Table 22. Order codes (automotive grade parts)

Order code	Temperature range	Package	Packing	Marking
LMV821IYLT	-40 ° C to +125 ° C Automotive grade <sup>(1)</sup>	SOT23-5	Tape & reel	K167
LMV822IYST		MiniSO8		K167
LMV822IYDT		SO8		LMV822IY
LMV824IYDT		SO14		LMV824IY
LMV824IYPT		TSSOP14		
LMV821AIYLT	-40 ° C to +125 ° C Automotive grade <sup>(1)</sup>	SOT23-5	Tape & reel	K168
LMV822AIYST		MiniSO8		K168
LMV822AIYDT		SO8		LMV822AY
LMV824AIYDT		SO14		
LMV824AIYPT		TSSOP14		LMV824AIY

1. Qualification and characterization according to AEC Q100 and Q003 or equivalent, advanced screening according to AEC Q001 & Q002 or equivalent.

## 7 Revision history

**Table 23. Document revision history**

Date	Revision	Changes
10-Nov-2011	1	Initial release.
06-Jul-2012	2	Addition of automotive grade parts.
29-Jan-2013	3	<i>Description</i> and <i>Section 4.6: Macromodel</i> : small text changes. Updated <i>Figure 1</i> . Updated titles of <i>Figure 3</i> , <i>Figure 13</i> , and <i>Figure 27</i> . Updated <i>Table 10</i> , <i>Table 11</i> , <i>Table 12</i> , and <i>Table 22: Order codes</i> (automotive grade parts). <i>Section 4.7: Shutdown function</i> : added explanation of <i>Figure 23</i> and <i>Figure 24</i> .
10-Apr-2017	4	Updated <a href="#">Table 13</a> : "L" dimension changed from 0.5 mm to 0.425 mm. Minor text revisions throughout the document,

**IMPORTANT NOTICE – PLEASE READ CAREFULLY**

STMicroelectronics NV and its subsidiaries ("ST") reserve the right to make changes, corrections, enhancements, modifications, and improvements to ST products and/or to this document at any time without notice. Purchasers should obtain the latest relevant information on ST products before placing orders. ST products are sold pursuant to ST's terms and conditions of sale in place at the time of order acknowledgement.

Purchasers are solely responsible for the choice, selection, and use of ST products and ST assumes no liability for application assistance or the design of Purchasers' products.

No license, express or implied, to any intellectual property right is granted by ST herein.

Resale of ST products with provisions different from the information set forth herein shall void any warranty granted by ST for such product.



ST and the ST logo are trademarks of ST. All other product or service names are the property of their respective owners.

Information in this document supersedes and replaces information previously supplied in any prior versions of this document.

© 2017 STMicroelectronics – All rights reserved

## Looking for pricing, stock, or lifecycle information?

Click below to explore more details on WIN SOURCE:

-  [View LMV822IDT on WIN SOURCE](#)
-  [STMicroelectronics Information](#)

## Optimize Your Supply Chain with WIN SOURCE Solutions

-  Global Sourcing Solution
-  Obsolete Management
-  Cost Control Management
-  Shortage Management
-  Alternative Solution
-  Excess Inventory Management