



THE DATASHEET OF LMV716MMX/NOPB



LMV716 5 MHz, Low Noise, RRO, Dual Operational Amplifier with CMOS Input

Check for Samples: [LMV716](#)

FEATURES

- (Typical Values, $V^+ = 3.3V$, $T_A = 25^\circ C$, unless Otherwise Specified)
- Input Noise Voltage 12.8 nV/ \sqrt{Hz}
- Input Bias Current 0.6 pA
- Offset Voltage 1.6 mV
- CMRR 80 dB
- Open Loop Gain 122 dB
- Rail-to-Rail Output
- GBW 5 MHz
- Slew Rate 5.8 V/ μs
- Supply Current 1.6 mA
- Supply Voltage Range 2.7V to 5V
- Operating Temperature $-40^\circ C$ to $85^\circ C$
- 8-pin VSSOP Package

APPLICATIONS

- Active Filters
- Transimpedance Amplifiers
- Audio Preamp
- HDD Vibration Cancellation Circuitry

Typical Application Circuit

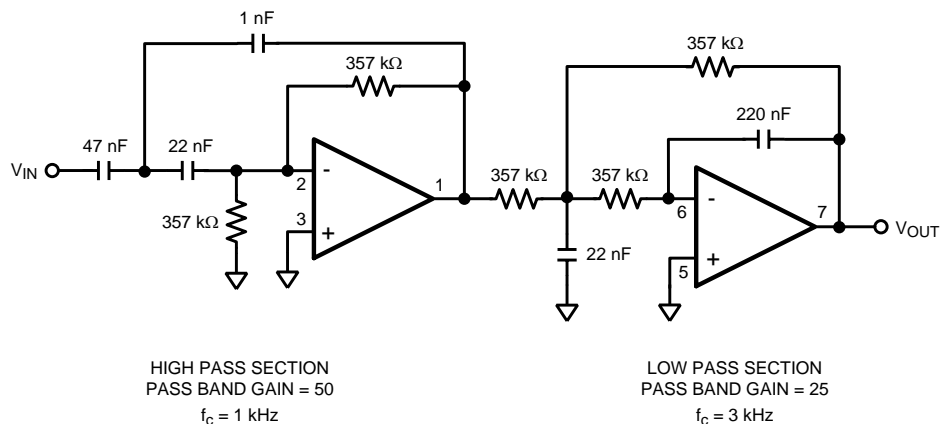
Figure 1. High Gain Band Pass Filter

DESCRIPTION

The LMV716 is a dual operational amplifier with both low supply voltage and low supply current, making it ideal for portable applications. The LMV716 CMOS input stage drives the I_{BIAS} current down to 0.6 pA; this coupled with the low noise voltage of 12.8 nV/ \sqrt{Hz} makes the LMV716 perfect for applications requiring active filters, transimpedance amplifiers, and HDD vibration cancellation circuitry.

Along with great noise sensitivity, small signal applications will benefit from the large gain bandwidth of 5 MHz coupled with the minimal supply current of 1.6 mA and a slew rate of 5.8 V/ μs .

The LMV716 provides rail-to-rail output swing into heavy loads. The input common-mode voltage range includes ground, which is ideal for ground sensing applications.

The LMV716 has a supply voltage spanning 2.7V to 5V and is offered in an 8-pin VSSOP package that functions across the wide temperature range of $-40^\circ C$ to $85^\circ C$. This small package makes it possible to place the LMV716 next to sensors, thus reducing external noise pickup.



Please be aware that an important notice concerning availability, standard warranty, and use in critical applications of Texas Instruments semiconductor products and disclaimers thereto appears at the end of this data sheet.

All trademarks are the property of their respective owners.



These devices have limited built-in ESD protection. The leads should be shorted together or the device placed in conductive foam during storage or handling to prevent electrostatic damage to the MOS gates.

Absolute Maximum Ratings ⁽¹⁾⁽²⁾

ESD Tolerance ⁽³⁾	
Human Body Model	2000V
Machine Model	200V
Supply Voltage (V ⁺ – V ⁻)	5.5V
Storage Temperature Range	-65°C to 150°C
Junction Temperature ⁽⁴⁾	150°C max
Mounting Temperature	
Infrared or Convection (20 sec)	260°C

- (1) Absolute Maximum Ratings indicate limits beyond which damage to the device may occur. Operating Ratings indicate conditions for which the device is intended to be functional, but specific performance is not ensured. For ensured specifications and the test conditions, see the Electrical Characteristics.
- (2) If Military/Aerospace specified devices are required, please contact the Texas Instruments Sales Office/ Distributors for availability and specifications.
- (3) Human Body Model is 1.5 kΩ in series with 100 pF. Machine Model is 0Ω in series with 100 pF.
- (4) The maximum power dissipation is a function of T_{J(MAX)}, θ_{JA} and T_A. The maximum allowable power dissipation at any ambient temperature is P_D = (T_{J(MAX)} - T_A) / θ_{JA}. All numbers apply for packages soldered directly into a PC board.

Operating Ratings ⁽¹⁾

Supply Voltage	2.7V to 5V
Temperature Range	-40°C to 85°C
Thermal Resistance (θ _{JA})	
8-Pin VSSOP	195°C/W

- (1) Absolute Maximum Ratings indicate limits beyond which damage to the device may occur. Operating Ratings indicate conditions for which the device is intended to be functional, but specific performance is not ensured. For ensured specifications and the test conditions, see the Electrical Characteristics.

3.3V Electrical Characteristics ⁽¹⁾

Unless otherwise specified, all limits are ensured for $T_J = 25^\circ\text{C}$, $V^+ = 3.3\text{V}$, $V^- = 0\text{V}$. $V_{\text{CM}} = V^+/2$. **Boldface** limits apply at the temperature extremes ⁽²⁾.

Symbol	Parameter	Condition	Min ⁽³⁾	Typ ⁽⁴⁾	Max ⁽³⁾	Units
V_{OS}	Input Offset Voltage	$V_{\text{CM}} = 1\text{V}$		1.6	5 6	mV
I_{B}	Input Bias Current	⁽⁵⁾		0.6	115 130	pA
I_{OS}	Input Offset Current			1		pA
CMRR	Common Mode Rejection Ratio	$0 \leq V_{\text{CM}} \leq 2.1\text{V}$	60 50	80		dB
PSRR	Power Supply Rejection Ratio	$2.7\text{V} \leq V^+ \leq 5\text{V}$, $V_{\text{CM}} = 1\text{V}$	70 60	82		dB
CMVR	Common Mode Voltage Range	For CMRR ≥ 50 dB	-0.2		2.2	V
A_{VOL}	Open Loop Voltage Gain	Sourcing $R_{\text{L}} = 10\text{ k}\Omega$ to $V^+/2$, $V_{\text{O}} = 1.65\text{V}$ to 2.9V	80 76	122		dB
		Sinking $R_{\text{L}} = 10\text{ k}\Omega$ to $V^+/2$, $V_{\text{O}} = 0.4\text{V}$ to 1.65V	80 76	122		
		Sourcing $R_{\text{L}} = 600\Omega$ to $V^+/2$, $V_{\text{O}} = 1.65\text{V}$ to 2.8V	80 76	105		
		Sinking $R_{\text{L}} = 600\Omega$ to $V^+/2$, $V_{\text{O}} = 0.5\text{V}$ to 1.65V	80 76	112		
V_{O}	Output Swing High	$R_{\text{L}} = 10\text{ k}\Omega$ to $V^+/2$	3.22 3.17	3.29		V
		$R_{\text{L}} = 600\Omega$ to $V^+/2$	3.12 3.07	3.22		
	Output Swing Low	$R_{\text{L}} = 10\text{ k}\Omega$ to $V^+/2$		0.03	0.12 0.16	
		$R_{\text{L}} = 600\Omega$ to $V^+/2$		0.07	0.23 0.27	
I_{OUT}	Output Current	Sourcing, $V_{\text{O}} = 0\text{V}$	20 15	31		mA
		Sinking, $V_{\text{O}} = 3.3\text{V}$	30 25	41		
I_{S}	Supply Current	$V_{\text{CM}} = 1\text{V}$		1.6	2.0 3	mA
SR	Slew Rate	⁽⁶⁾		5.8		V/ μs
GBW	Gain Bandwidth			5		MHz
e_{n}	Input-Referred Voltage Noise	$f = 1\text{ kHz}$		12.8		nV/ $\sqrt{\text{Hz}}$
i_{n}	Input-Referred Current Noise	$f = 1\text{ kHz}$		0.01		pA/ $\sqrt{\text{Hz}}$

(1) Electrical Table values apply only for factory testing conditions at the temperature indicated. Factor testing conditions result in very limited self-heating of the device such that $T_J = T_A$. No ensured specification of parametric performance is indicated in the electrical tables under conditions of internal self-heating where $T_J > T_A$. Absolute Maximum Ratings indicate junction temperature limits beyond which the device may be permanently degraded, either mechanically or electrically.

(2) Boldface limits apply to temperature range of -40°C to 85°C .

(3) All limits are specified by testing or statistical analysis.

(4) Typical values represent the most likely parametric norm.

(5) Input bias current is specified by design.

(6) Number specified is the lower of the positive and negative slew rates.

CONNECTION DIAGRAM

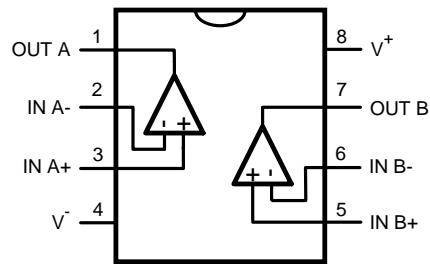
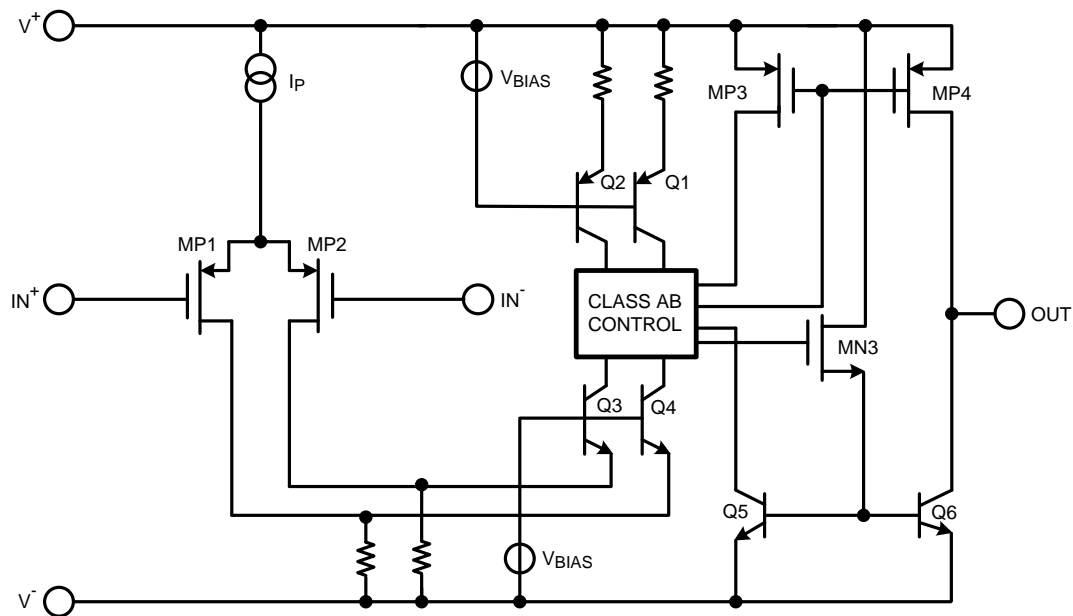

Figure 2. Top View - 8-Pin VSSOP

Simplified Schematic



Typical Performance Characteristics

Unless otherwise specified, $V^+ = 3.3V$, $T_J = 25^\circ C$.

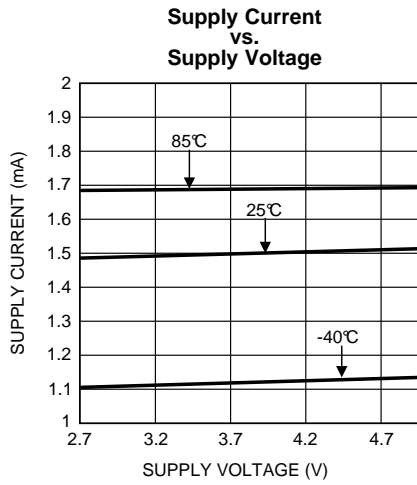

Figure 3.

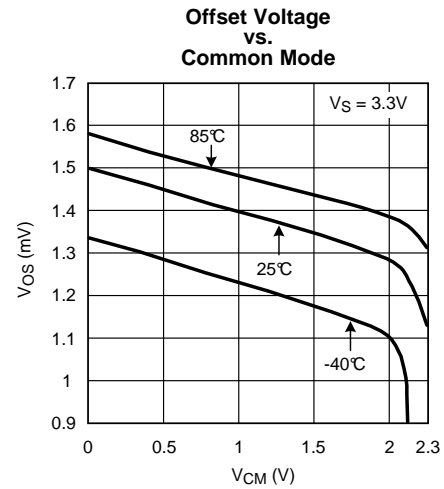

Figure 4.

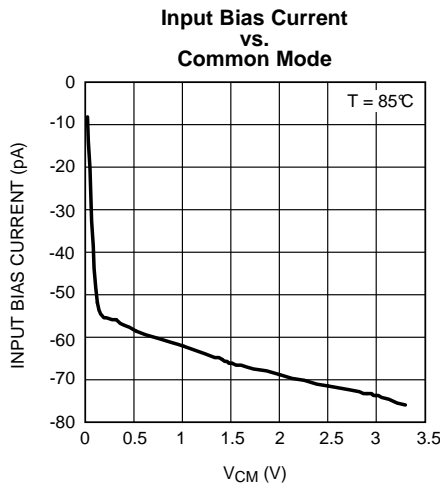

Figure 5.

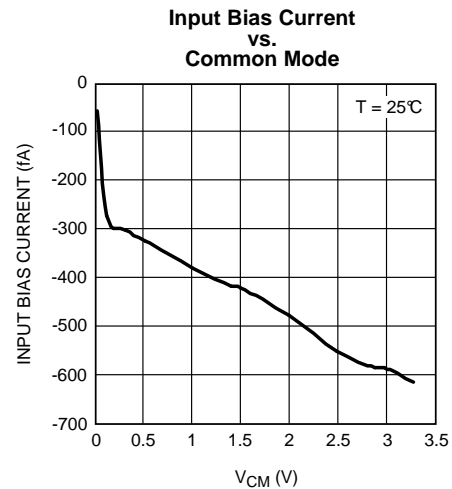

Figure 6.

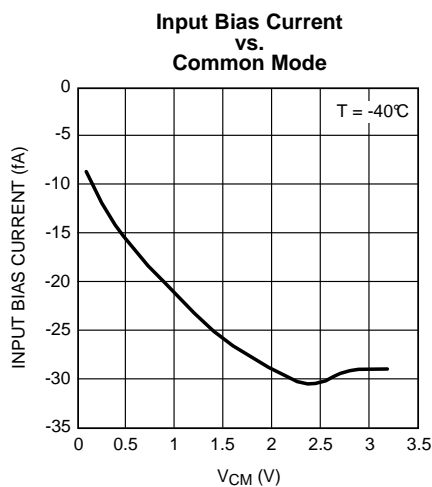

Figure 7.

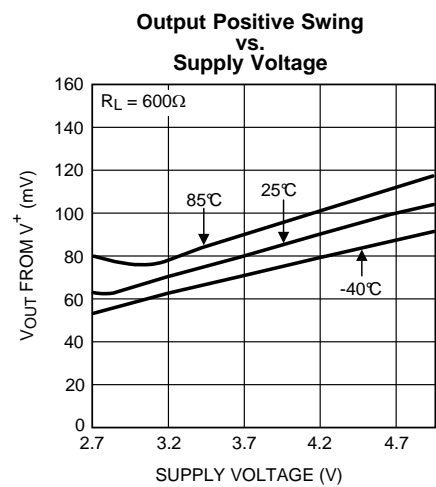

Figure 8.

Typical Performance Characteristics (continued)

Unless otherwise specified, $V^+ = 3.3V$, $T_J = 25^\circ C$.

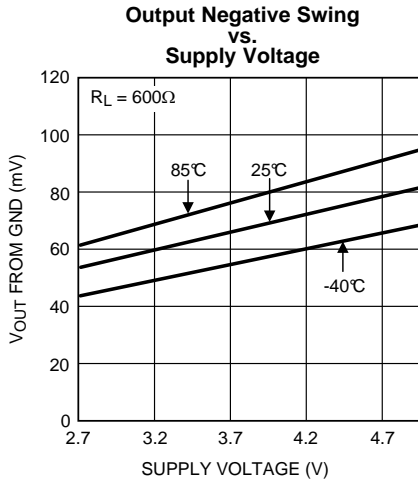

Figure 9.

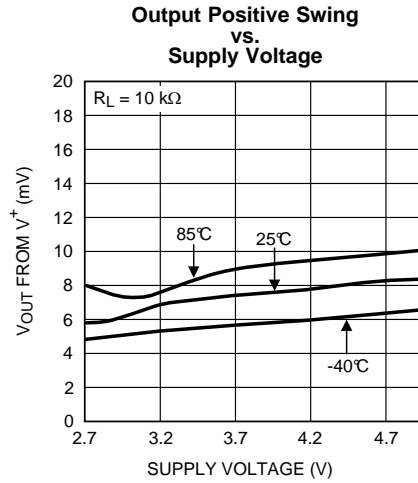

Figure 10.

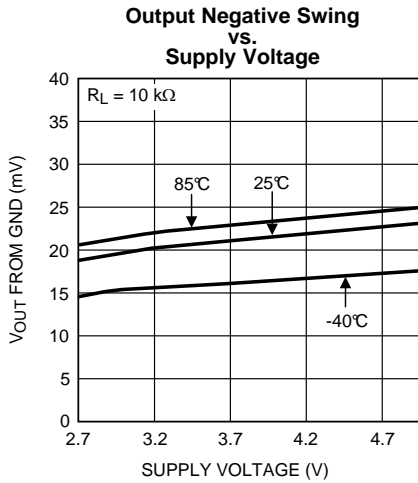

Figure 11.

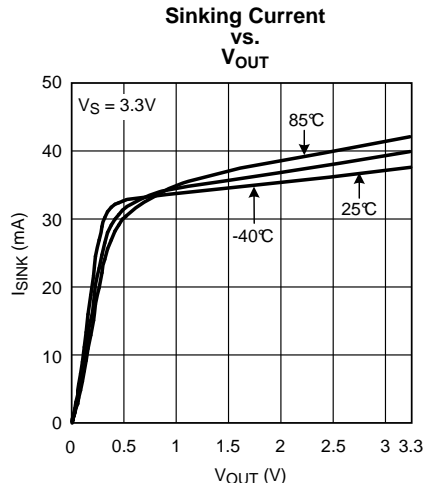

Figure 12.

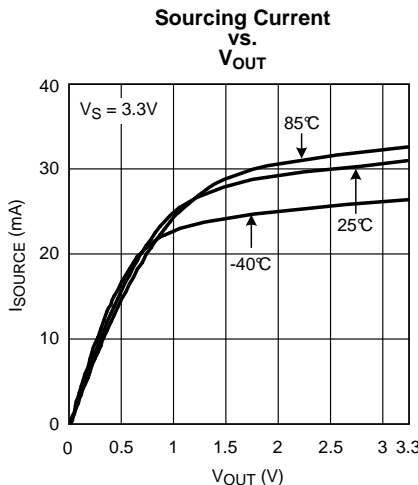

Figure 13.

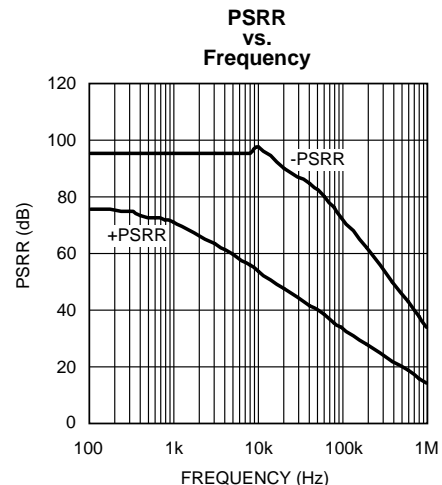

Figure 14.

Typical Performance Characteristics (continued)

Unless otherwise specified, $V^+ = 3.3V$, $T_J = 25^\circ C$.

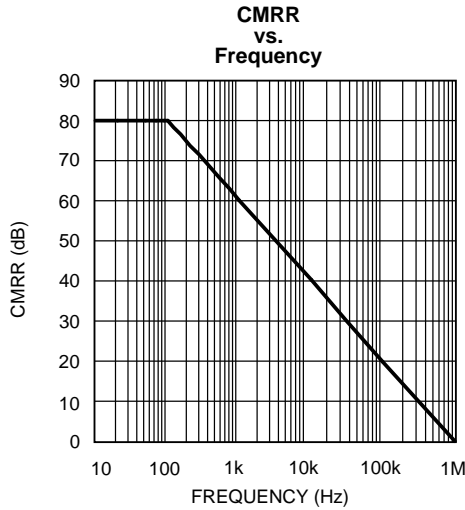

Figure 15.

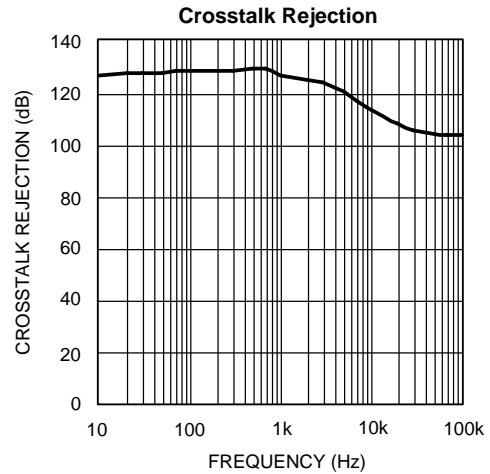

Figure 16.

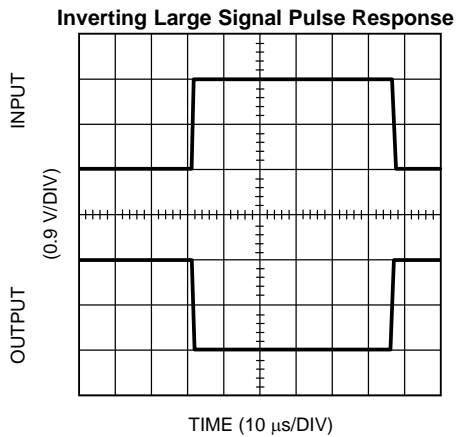

Figure 17.

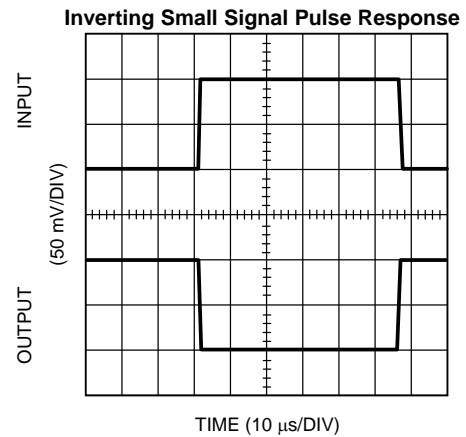

Figure 18.

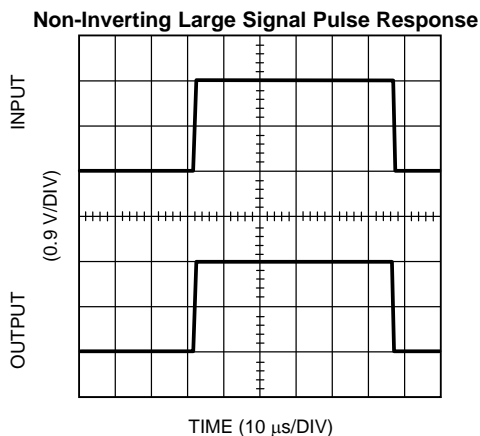

Figure 19.

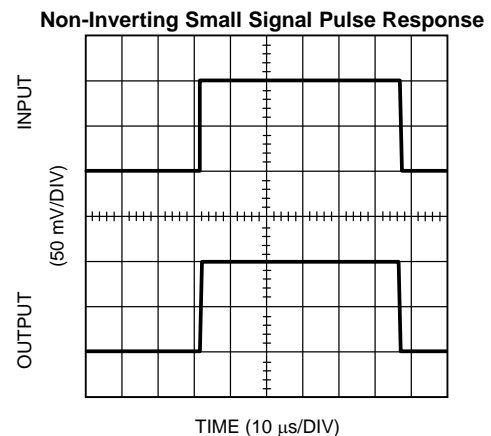

Figure 20.

Typical Performance Characteristics (continued)

Unless otherwise specified, $V^+ = 3.3V$, $T_J = 25^\circ C$.

Open Loop Frequency vs. R_L

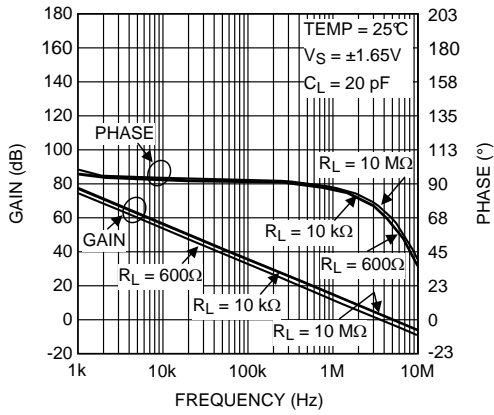

Figure 21.

Open Loop Frequency Response over Temperature

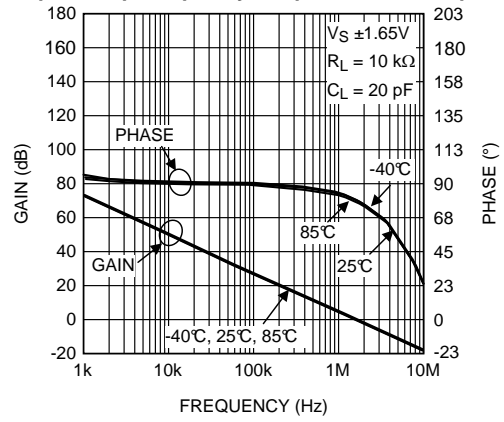

Figure 22.

Open Loop Frequency Response vs. C_L

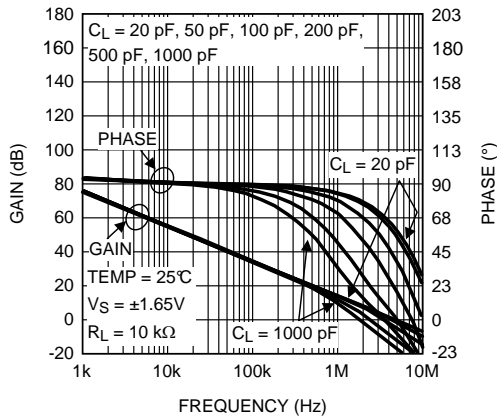

Figure 23.

Open Loop Frequency Response vs. C_L

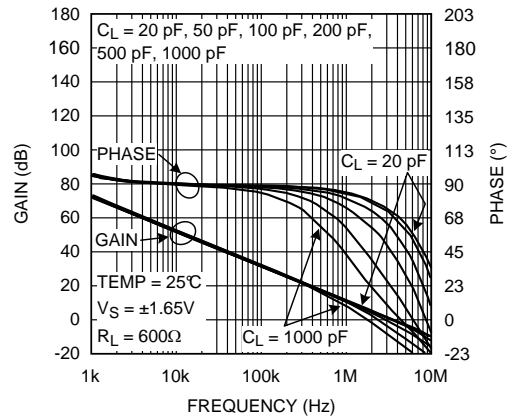

Figure 24.

Voltage Noise vs. Frequency

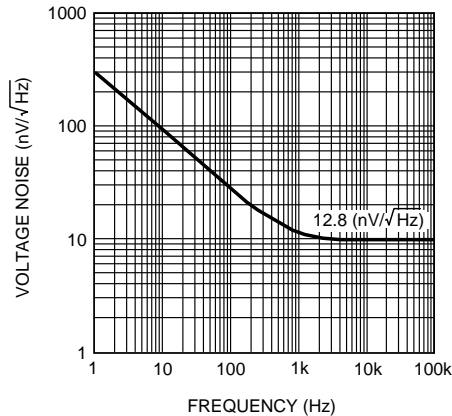

Figure 25.

APPLICATION INFORMATION

With the low supply current of only 1.6 mA, the LMV716 offers users the ability to maximize battery life. This makes the LMV716 ideal for battery powered systems. The LMV716's rail-to-rail output swing provides the maximum possible dynamic range at the output. This is particularly important when operating on low supply voltages.

CAPACITIVE LOAD TOLERANCE

The LMV716, when in a unity-gain configuration, can directly drive large capacitive loads in unity-gain without oscillation. The unity-gain follower is the most sensitive configuration to capacitive loading; direct capacitive loading reduces the phase margin of amplifiers. The combination of the amplifier's output impedance and the capacitive load induces phase lag. This results in either an underdamped pulse response or oscillation. To drive a heavier capacitive load, the circuit in [Figure 26](#) can be used.

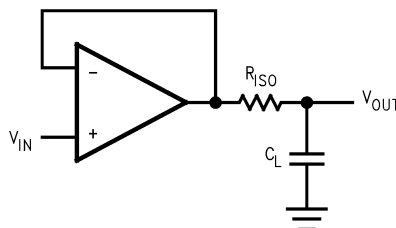

Figure 26. Indirectly Driving a Capacitive Load using Resistive Isolation

In [Figure 26](#), the isolation resistor R_{ISO} and the load capacitor C_L form a pole to increase stability by adding more phase margin to the overall system. The desired performance depends on the value of R_{ISO} . The bigger the R_{ISO} resistor value, the more stable V_{OUT} will be.

The circuit in [Figure 27](#) is an improvement to the one in [Figure 26](#) because it provides DC accuracy as well as AC stability. If there were a load resistor in [Figure 26](#), the output would be voltage divided by R_{ISO} and the load resistor. Instead, in [Figure 27](#), R_F provides the DC accuracy by using feed-forward techniques to connect V_{IN} to R_L . Due to the input bias current of the LMV716, the designer must be cautious when choosing the value of R_F . C_F and R_{ISO} serve to counteract the loss of phase margin by feeding the high frequency component of the output signal back to the amplifier's inverting input, thereby preserving phase margin in the overall feedback loop. Increased capacitive drive is possible by increasing the value of C_F . This in turn will slow down the pulse response.

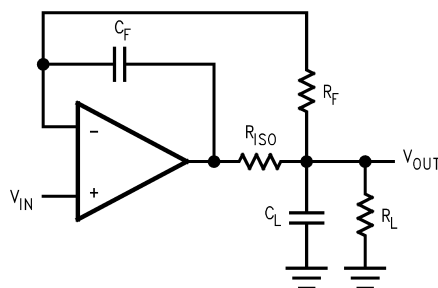

Figure 27. Indirectly Driving a Capacitive Load with DC Accuracy

DIFFERENCE AMPLIFIER

The difference amplifier allows the subtraction of two voltages or, as a special case, the cancellation of a signal common to two inputs. It is useful as a computational amplifier in making a differential to single-ended conversion or in rejecting a common mode signal.

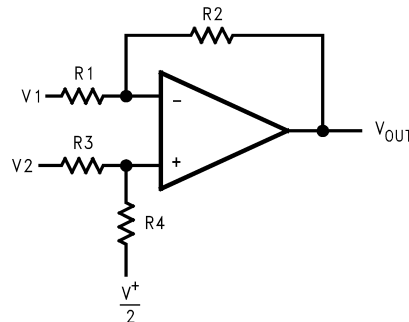

Figure 28. Difference Amplifier

$$V_{OUT} = \left(\frac{R1 + R2}{R3 + R4} \right) \frac{R4}{R1} V_2 - \frac{R2}{R1} V_1 + \left(\frac{R1 + R2}{R3 + R4} \right) \frac{R3}{R1} \cdot \frac{V^+}{2}$$

for $R1 = R3$ and $R2 = R4$

$$V_{OUT} = \frac{R2}{R1} (V_2 - V_1) + \frac{V^+}{2}$$

(1)

SINGLE-SUPPLY INVERTING AMPLIFIER

There may be cases where the input signal going into the amplifier is negative. Because the amplifier is operating in single supply voltage, a voltage divider using R_3 and R_4 is implemented to bias the amplifier so the inverting input signal is within the input common voltage range of the amplifier. The capacitor C_1 is placed between the inverting input and resistor R_1 to block the DC signal going into the AC signal source, V_{IN} . The values of R_1 and C_1 affect the cutoff frequency, $f_c = \frac{1}{2\pi R_1 C_1}$. As a result, the output signal is centered around mid-supply (if the voltage divider provides $V^+/2$ at the non-inverting input). The output can swing to both rails, maximizing the signal-to-noise ratio in a low voltage system.

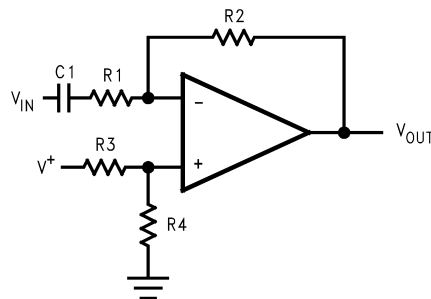

Figure 29. Single-supply Inverting Amplifier

$$V_{OUT} = -\frac{R2}{R1} V_{IN}$$

(2)

INSTRUMENTATION AMPLIFIER

Measurement of very small signals with an amplifier requires close attention to the input impedance of the amplifier, the overall signal gain from both inputs to the output, as well as, the gain from each input to the output. This is because we are only interested in the difference of the two inputs and the common signal is considered noise. A classic solution is an instrumentation amplifier. Instrumentation amplifiers have a finite, accurate, and stable gain. Also they have extremely high input impedances and very low output impedances. Finally they have an extremely high CMRR so that the amplifier can only respond to the differential signal.

Three-Op-Amp Instrumentation Amplifier

A typical instrumentation amplifier is shown in [Figure 30](#).

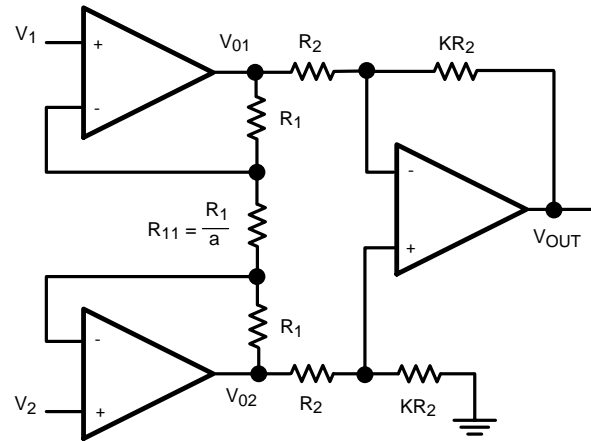

Figure 30. Three-Op-Amp Instrumentation Amplifier

There are two stages in this configuration. The last stage, the output stage, is a differential amplifier. In an ideal case the two amplifiers of the first stage, the input stage, would be set up as buffers to isolate the inputs. However they cannot be connected as followers due to the mismatch of real amplifiers. The circuit in [Figure 30](#) utilizes a balancing resistor between the two amplifiers to compensate for this mismatch. The product of the two stages of gain will be the gain of the instrumentation amplifier circuit. Ideally, the CMRR should be infinite. However the output stage has a small non-zero common mode gain which results from resistor mismatch.

In the input stage of the circuit, current is the same across all resistors. This is due to the high input impedance and low input bias current of the LMV716. With the node equations we have:

$$\text{GIVEN: } I_{R1} = I_{R11} \tag{3}$$

By Ohm's Law:

$$\begin{aligned} V_{O1} - V_{O2} &= (2R_1 + R_{11}) I_{R11} \\ &= (2a + 1) R_{11} \cdot I_{R11} \\ &= (2a + 1) V_{R11} \end{aligned} \tag{4}$$

However:

$$V_{R11} = V_1 - V_2 \tag{5}$$

So we have:

$$V_{O1} - V_{O2} = (2a + 1) (V_1 - V_2) \tag{6}$$

Now looking at the output of the instrumentation amplifier:

$$\begin{aligned} V_O &= \frac{KR_2}{R_2} (V_{O2} - V_{O1}) \\ &= -K (V_{O1} - V_{O2}) \end{aligned} \tag{7}$$

Substituting from [Equation 6](#):

$$V_O = -K (2a + 1) (V_1 - V_2) \tag{8}$$

This shows the gain of the instrumentation amplifier to be:

$$-K(2a+1) \quad (9)$$

Typical values for this circuit can be obtained by setting: $a = 12$ and $K = 4$. This results in an overall gain of -100 .

Three LMV716 amplifiers are used along with 1% resistors to minimize resistor mismatch. Resistors used to build the circuit are: $R_1 = 21.6 \text{ k}\Omega$, $R_{11} = 1.8 \text{ k}\Omega$, $R_2 = 2.5 \text{ k}\Omega$ with $K = 40$ and $a = 12$. This results in an overall gain of $-K(2a+1) = -1000$.

Two-Op-Amp Instrumentation Amplifier

A two-op-amp instrumentation amplifier can also be used to make a high-input impedance DC differential amplifier (Figure 31). As in the three op amp circuit, this instrumentation amplifier requires precise resistor matching for good CMRR. R_4 should be equal to R_1 , and R_3 should equal R_2 .

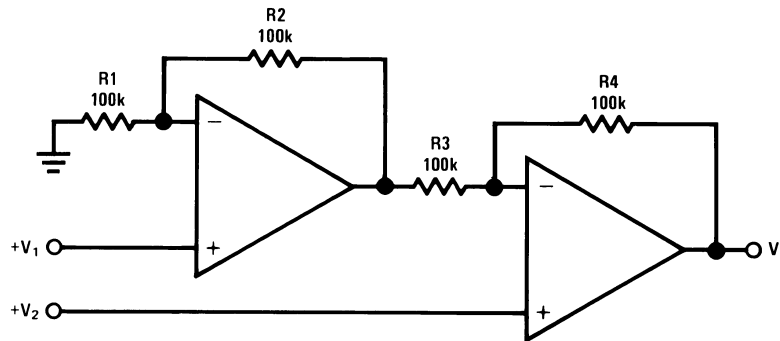

Figure 31. Two-Op-Amp Instrumentation Amplifier

$$V_0 = \left(1 + \frac{R_4}{R_3}\right)(V_2 - V_1), \text{ where } R_1 = R_4 \text{ and } R_2 = R_3$$

$$\text{As shown: } V_0 = 2(V_2 - V_1) \quad (10)$$

ACTIVE FILTERS

Active filters are circuits with amplifiers, resistors, and capacitors. The use of amplifiers instead of inductors, which are used in passive filters, enhances the circuit performance while reducing the size and complexity of the filter. The simplest active filters are designed using an inverting op amp configuration where at least one reactive element has been added to the configuration. This means that the op amp will provide "frequency-dependent" amplification, since reactive elements are frequency dependent devices.

Low Pass Filter

The following shows a very simple low pass filter.

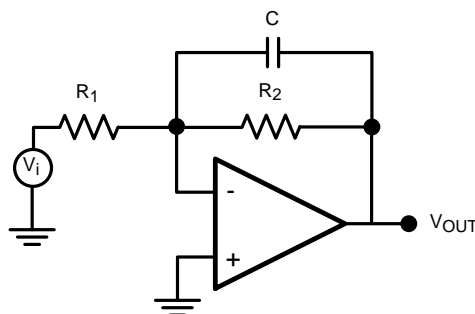

Figure 32. Low Pass Filter

The transfer function can be expressed as follows:

By KCL:

$$\frac{-V_i}{R_1} - \frac{V_O}{\left[\frac{1}{j\omega C} \right]} - \frac{V_O}{R_2} = 0 \quad (11)$$

Simplifying this further results in:

$$V_O = \frac{-R_2}{R_1} \left[\frac{1}{j\omega C R_2 + 1} \right] V_i \quad (12)$$

or

$$\frac{V_O}{V_i} = \frac{-R_2}{R_1} \left[\frac{1}{j\omega C R_2 + 1} \right] \quad (13)$$

Now, substituting $\omega = 2\pi f$, so that the calculations are in $f(\text{Hz})$ rather than in $\omega(\text{rad/s})$, and setting the DC gain

$$\left[\frac{-R_2}{R_1} = H_0 \right] \text{ and } H = \frac{V_O}{V_i}$$

$$H = H_0 \left[\frac{1}{j2\pi f C R_2 + 1} \right] \quad (14)$$

$$f_0 = \frac{1}{2\pi R_1 C}$$

set:

$$H = H_0 \left[\frac{1}{1 + j(f/f_0)} \right] \quad (15)$$

Low pass filters are known as lossy integrators because they only behave as integrators at higher frequencies. The general form of the bode plot can be predicted just by looking at the transfer function. When the f/f_0 ratio is small, the capacitor is, in effect, an open circuit and the amplifier behaves at a set DC gain. Starting at f_0 , which is the -3 dB corner, the capacitor will have the dominant impedance and hence the circuit will behave as an integrator and the signal will be attenuated and eventually cut. The bode plot for this filter is shown in [Figure 33](#).

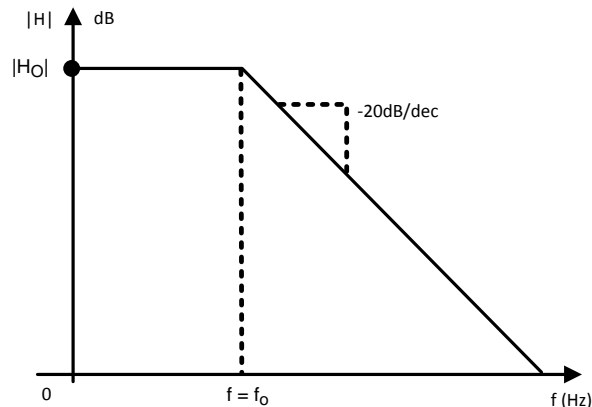

Figure 33. Low Pass Filter Transfer Function

High Pass Filter

The transfer function of a high pass filter can be derived in much the same way as the previous example. A typical first order high pass filter is shown below:

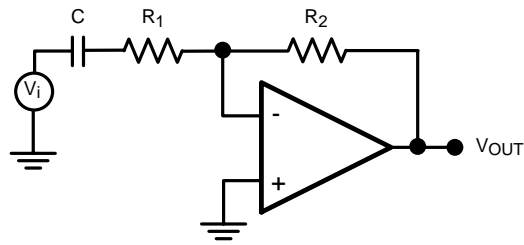

Figure 34. High Pass Filter

Writing the KCL for this circuit :

(V_1 denotes the voltage between C and R_1)

$$\frac{V_1 - V_i}{\frac{1}{j\omega C}} = \frac{V_1 - \bar{V}}{R_1} \quad (16)$$

$$\frac{\bar{V} + V_1}{R_1} = \frac{\bar{V} + V_O}{R_2} \quad (17)$$

Solving these two equations to find the transfer function and using:

$$f_0 = \frac{1}{2\pi R_1 C} \quad (18)$$

(high frequency gain) $H_0 = \frac{-R_2}{R_1}$ and $H = \frac{V_O}{V_i}$

Which gives:

$$H = H_0 \frac{j(f/f_0)}{1 + j(f/f_0)} \quad (19)$$

Looking at the transfer function, it is clear that when f/f_0 is small, the capacitor is open and therefore, no signal is getting to the amplifier. As the frequency increases the amplifier starts operating. At $f = f_0$ the capacitor behaves like a short circuit and the amplifier will have a constant, high frequency gain of H_0 . [Figure 35](#) shows the transfer function of this high pass filter.

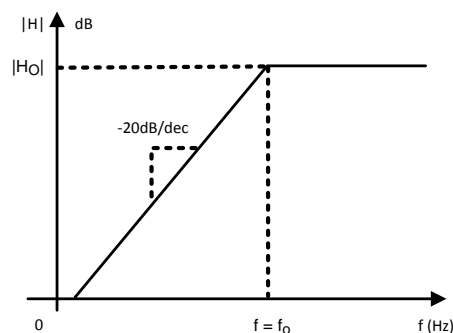

Figure 35. High Pass Filter Transfer Function

Band Pass Filter

Combining a low pass filter and a high pass filter will generate a band pass filter. Figure 36 offers an example of this type of circuit.

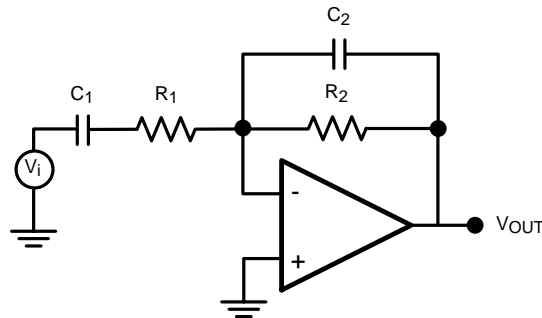

Figure 36. Band Pass Filter

In this network the input impedance forms the high pass filter while the feedback impedance forms the low pass filter. If the designer chooses the corner frequencies so that $f_1 < f_2$, then all the frequencies between, $f_1 \leq f \leq f_2$, will pass through the filter while frequencies below f_1 and above f_2 will be cut off.

The transfer function can be easily calculated using the same methodology as before and is shown in Figure 37.

$$H = H_0 \frac{j(f/f_1)}{[1 + j(f/f_1)] [1 + j(f/f_2)]} \quad (20)$$

Where

$$f_1 = \frac{1}{2\pi R_1 C_1}$$

$$f_2 = \frac{1}{2\pi R_2 C_2}$$

$$H_0 = \frac{-R_2}{R_1}$$

(21)

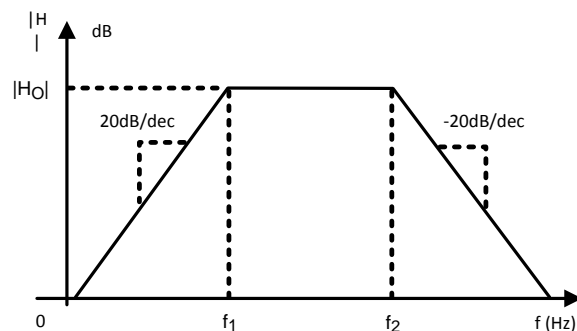

Figure 37. Band Pass Filter Transfer Function

STATE VARIABLE ACTIVE FILTER

State variable active filters are circuits that can simultaneously represent high pass, band pass, and low pass filters. The state variable active filter uses three separate amplifiers to achieve this task. A typical state variable active filter is shown in Figure 38. The first amplifier in the circuit is connected as a gain stage. The second and third amplifiers are connected as integrators, which means they behave as low pass filters. The feedback path from the output of the third amplifier to the first amplifier enables this low frequency signal to be fed back with a

finite and fairly low closed loop gain. This is while the high frequency signal on the input is still gained up by the open loop gain of the first amplifier. This makes the first amplifier a high pass filter. The high pass signal is then fed into a low pass filter. The outcome is a band pass signal, meaning the second amplifier is a band pass filter. This signal is then fed into the third amplifiers input and so, the third amplifier behaves as a simple low pass filter.

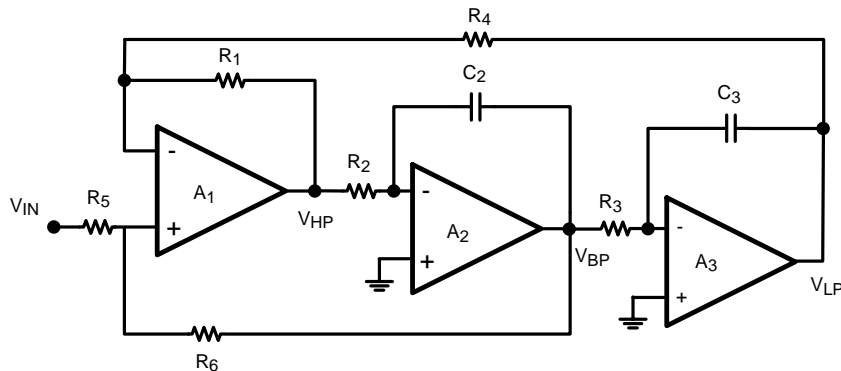
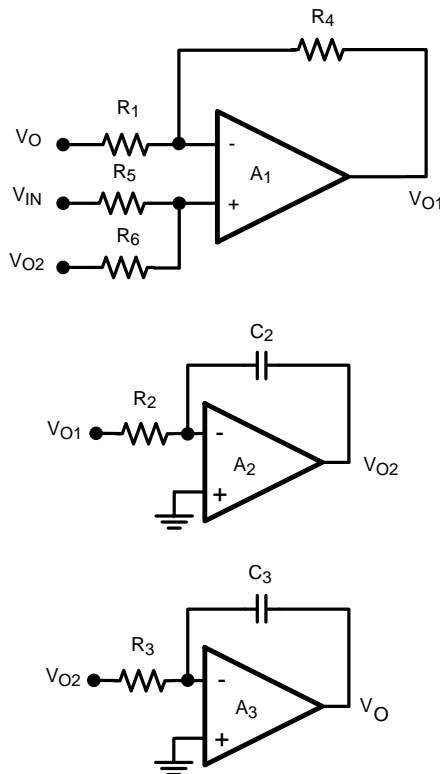

Figure 38. State Variable Active Filter

The transfer function of each filter needs to be calculated. The derivations will be more trivial if each stage of the filter is shown on its own.

The three components are:



For A₁ the relationship between input and output is:

$$V_{O1} = \frac{-R_4}{R_1} V_0 + \left[\frac{R_6}{R_5 + R_6} \right] \left[\frac{R_1 + R_4}{R_1} \right] V_{IN} + \left[\frac{R_5}{R_5 + R_6} \right] \left[\frac{R_1 + R_4}{R_1} \right] V_{O2} \tag{22}$$

This relationship depends on the output of all the filters. The input-output relationship for A_2 can be expressed as:

$$V_{O2} = \frac{-1}{s C_2 R_2} V_{O1} \quad (23)$$

And finally this relationship for A_3 is as follows:

$$V_O = \frac{-1}{s C_3 R_3} V_{O2} \quad (24)$$

Re-arranging these equations, one can find the relationship between V_O and V_{IN} (transfer function of the low pass filter), V_{O1} and V_{IN} (transfer function of the high pass filter), and V_{O2} and V_{IN} (transfer function of the band pass filter) These relationships are as follows:

Low Pass Filter

$$\frac{V_O}{V_{IN}} = \frac{\left[\frac{R_1 + R_4}{R_1} \right] \left[\frac{R_6}{R_5 + R_6} \right] \left[\frac{1}{C_2 C_3 R_2 R_3} \right]}{s^2 + s \left[\frac{1}{C_2 R_2} \right] \left[\frac{R_5}{R_5 + R_6} \right] \left[\frac{R_1 + R_4}{R_1} \right] + \left[\frac{1}{C_2 C_3 R_2 R_3} \right]} \quad (25)$$

(26)

High Pass Filter

$$\frac{V_{O1}}{V_{IN}} = \frac{s^2 \left[\frac{R_1 + R_4}{R_1} \right] \left[\frac{R_6}{R_5 + R_6} \right]}{s^2 + s \left[\frac{1}{C_2 R_2} \right] \left[\frac{R_5}{R_5 + R_6} \right] \left[\frac{R_1 + R_4}{R_1} \right] + \left[\frac{1}{C_2 C_3 R_2 R_3} \right]} \quad (27)$$

Band Pass Filter

$$\frac{V_{O2}}{V_{IN}} = \frac{s \left[\frac{1}{C_2 R_2} \right] \left[\frac{R_1 + R_4}{R_1} \right] \left[\frac{R_6}{R_5 + R_6} \right]}{s^2 + s \left[\frac{1}{C_2 R_2} \right] \left[\frac{R_5}{R_5 + R_6} \right] \left[\frac{R_1 + R_4}{R_1} \right] + \left[\frac{1}{C_2 C_3 R_2 R_3} \right]} \quad (28)$$

The center frequency and Quality Factor for all of these filters is the same. The values can be calculated in the following manner:

$$\omega_c = \sqrt{\frac{1}{C_2 C_3 R_2 R_3}}$$

and

$$Q = \sqrt{\frac{C_2 R_2}{C_3 R_3} \left[\frac{R_5 + R_6}{R_6} \right] \left[\frac{R_1}{R_1 + R_4} \right]} \quad (29)$$

Designing a band pass filter with a center frequency of 10 kHz and Quality Factor of 5.5

To do this, first consider the Quality Factor. It is best to pick convenient values for the capacitors. $C_2 = C_3 = 1000$ pF. Also, choose $R_1 = R_4 = 30$ k Ω . Now values of R_5 and R_6 need to be calculated. With the chosen values for the capacitors and resistors, Q reduces to:

$$Q = \frac{11}{2} = \frac{1}{2} \left[\frac{R_5 + R_6}{R_6} \right] \quad (30)$$

or

$$R_5 = 10R_6 \quad R_6 = 1.5 \text{ k}\Omega \quad R_5 = 15 \text{ k}\Omega \quad (31)$$

Also, for $f = 10 \text{ kHz}$, the center frequency is $\omega c = 2\pi f = 62.8 \text{ kHz}$.

Using the expressions above, the appropriate resistor values will be $R_2 = R_3 = 16 \text{ k}\Omega$.

The DC gain of this circuit is:

$$\text{DC GAIN} = \left[\frac{R_1 + R_4}{R_1} \right] \left[\frac{R_6}{R_5 + R_6} \right] = -14.8 \text{ dB} \quad (32)$$

REVISION HISTORY

Changes from Revision A (March 2013) to Revision B	Page
<hr/> <ul style="list-style-type: none">• Changed layout of National Data Sheet to TI format	<hr/> 18

PACKAGING INFORMATION

Orderable Device	Status (1)	Package Type	Package Drawing	Pins	Package Qty	Eco Plan (2)	Lead/Ball Finish (6)	MSL Peak Temp (3)	Op Temp (°C)	Device Marking (4/5)	Samples
LMV716MM/NOPB	ACTIVE	VSSOP	DGK	8	1000	Green (RoHS & no Sb/Br)	CU SN	Level-1-260C-UNLIM	-40 to 85	AR3A	Samples

(1) The marketing status values are defined as follows:

ACTIVE: Product device recommended for new designs.

LIFEBUY: TI has announced that the device will be discontinued, and a lifetime-buy period is in effect.

NRND: Not recommended for new designs. Device is in production to support existing customers, but TI does not recommend using this part in a new design.

PREVIEW: Device has been announced but is not in production. Samples may or may not be available.

OBSOLETE: TI has discontinued the production of the device.

(2) **RoHS:** TI defines "RoHS" to mean semiconductor products that are compliant with the current EU RoHS requirements for all 10 RoHS substances, including the requirement that RoHS substance do not exceed 0.1% by weight in homogeneous materials. Where designed to be soldered at high temperatures, "RoHS" products are suitable for use in specified lead-free processes. TI may reference these types of products as "Pb-Free".

RoHS Exempt: TI defines "RoHS Exempt" to mean products that contain lead but are compliant with EU RoHS pursuant to a specific EU RoHS exemption.

Green: TI defines "Green" to mean the content of Chlorine (Cl) and Bromine (Br) based flame retardants meet JS709B low halogen requirements of <=1000ppm threshold. Antimony trioxide based flame retardants must also meet the <=1000ppm threshold requirement.

(3) MSL, Peak Temp. - The Moisture Sensitivity Level rating according to the JEDEC industry standard classifications, and peak solder temperature.

(4) There may be additional marking, which relates to the logo, the lot trace code information, or the environmental category on the device.

(5) Multiple Device Markings will be inside parentheses. Only one Device Marking contained in parentheses and separated by a "~" will appear on a device. If a line is indented then it is a continuation of the previous line and the two combined represent the entire Device Marking for that device.

(6) Lead/Ball Finish - Orderable Devices may have multiple material finish options. Finish options are separated by a vertical ruled line. Lead/Ball Finish values may wrap to two lines if the finish value exceeds the maximum column width.

Important Information and Disclaimer:The information provided on this page represents TI's knowledge and belief as of the date that it is provided. TI bases its knowledge and belief on information provided by third parties, and makes no representation or warranty as to the accuracy of such information. Efforts are underway to better integrate information from third parties. TI has taken and continues to take reasonable steps to provide representative and accurate information but may not have conducted destructive testing or chemical analysis on incoming materials and chemicals. TI and TI suppliers consider certain information to be proprietary, and thus CAS numbers and other limited information may not be available for release.

In no event shall TI's liability arising out of such information exceed the total purchase price of the TI part(s) at issue in this document sold by TI to Customer on an annual basis.

TAPE AND REEL INFORMATION



QUADRANT ASSIGNMENTS FOR PIN 1 ORIENTATION IN TAPE



*All dimensions are nominal

Device	Package Type	Package Drawing	Pins	SPQ	Reel Diameter (mm)	Reel Width W1 (mm)	A0 (mm)	B0 (mm)	K0 (mm)	P1 (mm)	W (mm)	Pin1 Quadrant
LMV716MM/NOPB	VSSOP	DGK	8	1000	178.0	12.4	5.3	3.4	1.4	8.0	12.0	Q1

TAPE AND REEL BOX DIMENSIONS



*All dimensions are nominal

Device	Package Type	Package Drawing	Pins	SPQ	Length (mm)	Width (mm)	Height (mm)
LMV716MM/NOPB	VSSOP	DGK	8	1000	210.0	185.0	35.0

DGK (S-PDSO-G8)

PLASTIC SMALL-OUTLINE PACKAGE

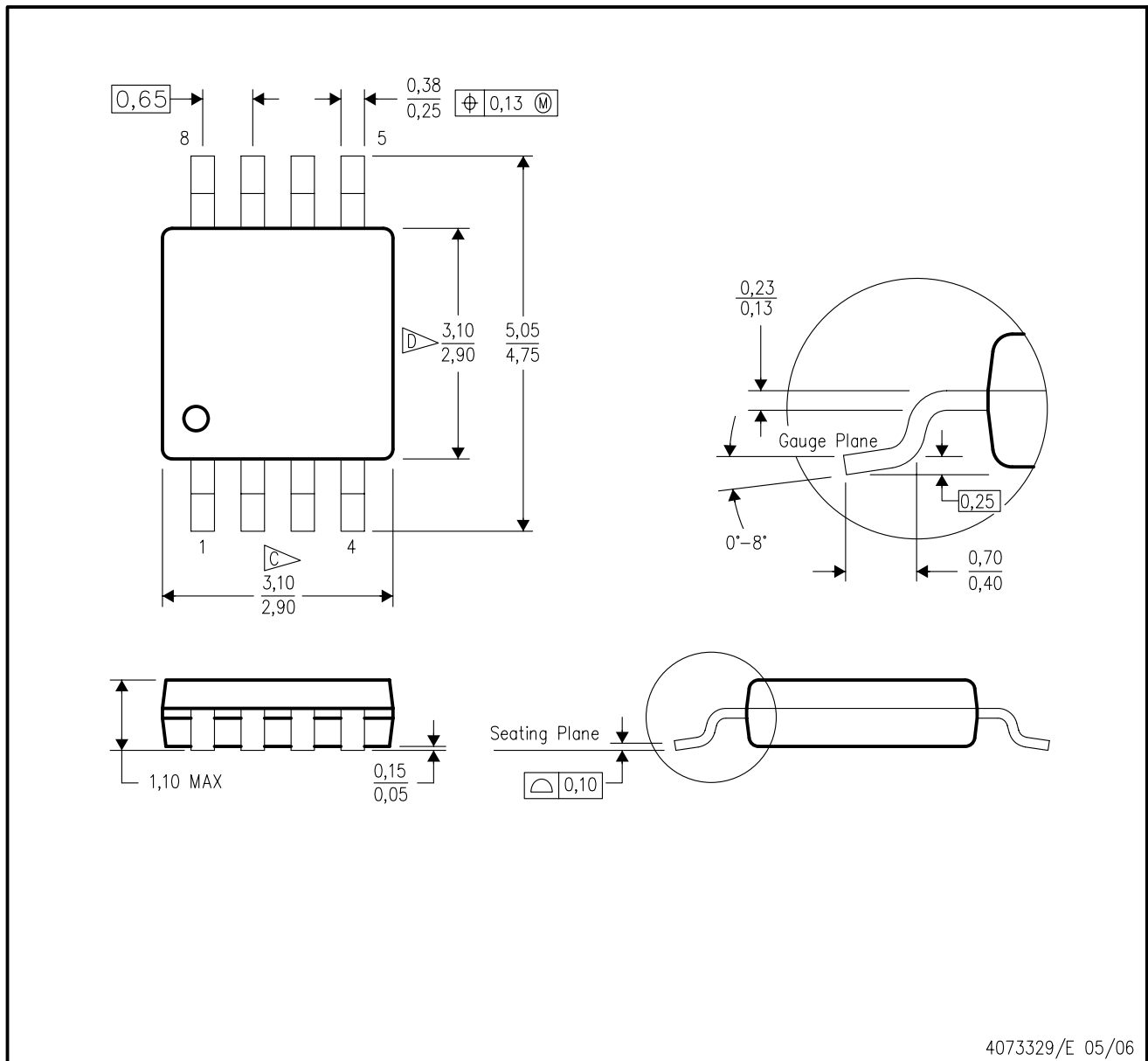

4073329/E 05/06

- NOTES:
- A. All linear dimensions are in millimeters.
 - B. This drawing is subject to change without notice.
 - C. Body length does not include mold flash, protrusions, or gate burrs. Mold flash, protrusions, or gate burrs shall not exceed 0.15 per end.
 - D. Body width does not include interlead flash. Interlead flash shall not exceed 0.50 per side.
 - E. Falls within JEDEC MO-187 variation AA, except interlead flash.



- NOTES:
- A. All linear dimensions are in millimeters.
 - B. This drawing is subject to change without notice.
 - C. Publication IPC-7351 is recommended for alternate designs.
 - D. Laser cutting apertures with trapezoidal walls and also rounding corners will offer better paste release. Customers should contact their board assembly site for stencil design recommendations. Refer to IPC-7525 for other stencil recommendations.
 - E. Customers should contact their board fabrication site for solder mask tolerances between and around signal pads.

IMPORTANT NOTICE

Texas Instruments Incorporated (TI) reserves the right to make corrections, enhancements, improvements and other changes to its semiconductor products and services per JESD46, latest issue, and to discontinue any product or service per JESD48, latest issue. Buyers should obtain the latest relevant information before placing orders and should verify that such information is current and complete.

TI's published terms of sale for semiconductor products (<http://www.ti.com/sc/docs/stdterms.htm>) apply to the sale of packaged integrated circuit products that TI has qualified and released to market. Additional terms may apply to the use or sale of other types of TI products and services.

Reproduction of significant portions of TI information in TI data sheets is permissible only if reproduction is without alteration and is accompanied by all associated warranties, conditions, limitations, and notices. TI is not responsible or liable for such reproduced documentation. Information of third parties may be subject to additional restrictions. Resale of TI products or services with statements different from or beyond the parameters stated by TI for that product or service voids all express and any implied warranties for the associated TI product or service and is an unfair and deceptive business practice. TI is not responsible or liable for any such statements.

Buyers and others who are developing systems that incorporate TI products (collectively, "Designers") understand and agree that Designers remain responsible for using their independent analysis, evaluation and judgment in designing their applications and that Designers have full and exclusive responsibility to assure the safety of Designers' applications and compliance of their applications (and of all TI products used in or for Designers' applications) with all applicable regulations, laws and other applicable requirements. Designer represents that, with respect to their applications, Designer has all the necessary expertise to create and implement safeguards that (1) anticipate dangerous consequences of failures, (2) monitor failures and their consequences, and (3) lessen the likelihood of failures that might cause harm and take appropriate actions. Designer agrees that prior to using or distributing any applications that include TI products, Designer will thoroughly test such applications and the functionality of such TI products as used in such applications.

TI's provision of technical, application or other design advice, quality characterization, reliability data or other services or information, including, but not limited to, reference designs and materials relating to evaluation modules, (collectively, "TI Resources") are intended to assist designers who are developing applications that incorporate TI products; by downloading, accessing or using TI Resources in any way, Designer (individually or, if Designer is acting on behalf of a company, Designer's company) agrees to use any particular TI Resource solely for this purpose and subject to the terms of this Notice.

TI's provision of TI Resources does not expand or otherwise alter TI's applicable published warranties or warranty disclaimers for TI products, and no additional obligations or liabilities arise from TI providing such TI Resources. TI reserves the right to make corrections, enhancements, improvements and other changes to its TI Resources. TI has not conducted any testing other than that specifically described in the published documentation for a particular TI Resource.

Designer is authorized to use, copy and modify any individual TI Resource only in connection with the development of applications that include the TI product(s) identified in such TI Resource. NO OTHER LICENSE, EXPRESS OR IMPLIED, BY ESTOPPEL OR OTHERWISE TO ANY OTHER TI INTELLECTUAL PROPERTY RIGHT, AND NO LICENSE TO ANY TECHNOLOGY OR INTELLECTUAL PROPERTY RIGHT OF TI OR ANY THIRD PARTY IS GRANTED HEREIN, including but not limited to any patent right, copyright, mask work right, or other intellectual property right relating to any combination, machine, or process in which TI products or services are used. Information regarding or referencing third-party products or services does not constitute a license to use such products or services, or a warranty or endorsement thereof. Use of TI Resources may require a license from a third party under the patents or other intellectual property of the third party, or a license from TI under the patents or other intellectual property of TI.

TI RESOURCES ARE PROVIDED "AS IS" AND WITH ALL FAULTS. TI DISCLAIMS ALL OTHER WARRANTIES OR REPRESENTATIONS, EXPRESS OR IMPLIED, REGARDING RESOURCES OR USE THEREOF, INCLUDING BUT NOT LIMITED TO ACCURACY OR COMPLETENESS, TITLE, ANY EPIDEMIC FAILURE WARRANTY AND ANY IMPLIED WARRANTIES OF MERCHANTABILITY, FITNESS FOR A PARTICULAR PURPOSE, AND NON-INFRINGEMENT OF ANY THIRD PARTY INTELLECTUAL PROPERTY RIGHTS. TI SHALL NOT BE LIABLE FOR AND SHALL NOT DEFEND OR INDEMNIFY DESIGNER AGAINST ANY CLAIM, INCLUDING BUT NOT LIMITED TO ANY INFRINGEMENT CLAIM THAT RELATES TO OR IS BASED ON ANY COMBINATION OF PRODUCTS EVEN IF DESCRIBED IN TI RESOURCES OR OTHERWISE. IN NO EVENT SHALL TI BE LIABLE FOR ANY ACTUAL, DIRECT, SPECIAL, COLLATERAL, INDIRECT, PUNITIVE, INCIDENTAL, CONSEQUENTIAL OR EXEMPLARY DAMAGES IN CONNECTION WITH OR ARISING OUT OF TI RESOURCES OR USE THEREOF, AND REGARDLESS OF WHETHER TI HAS BEEN ADVISED OF THE POSSIBILITY OF SUCH DAMAGES.

Unless TI has explicitly designated an individual product as meeting the requirements of a particular industry standard (e.g., ISO/TS 16949 and ISO 26262), TI is not responsible for any failure to meet such industry standard requirements.

Where TI specifically promotes products as facilitating functional safety or as compliant with industry functional safety standards, such products are intended to help enable customers to design and create their own applications that meet applicable functional safety standards and requirements. Using products in an application does not by itself establish any safety features in the application. Designers must ensure compliance with safety-related requirements and standards applicable to their applications. Designer may not use any TI products in life-critical medical equipment unless authorized officers of the parties have executed a special contract specifically governing such use. Life-critical medical equipment is medical equipment where failure of such equipment would cause serious bodily injury or death (e.g., life support, pacemakers, defibrillators, heart pumps, neurostimulators, and implantables). Such equipment includes, without limitation, all medical devices identified by the U.S. Food and Drug Administration as Class III devices and equivalent classifications outside the U.S.

TI may expressly designate certain products as completing a particular qualification (e.g., Q100, Military Grade, or Enhanced Product). Designers agree that it has the necessary expertise to select the product with the appropriate qualification designation for their applications and that proper product selection is at Designers' own risk. Designers are solely responsible for compliance with all legal and regulatory requirements in connection with such selection.

Designer will fully indemnify TI and its representatives against any damages, costs, losses, and/or liabilities arising out of Designer's non-compliance with the terms and provisions of this Notice.

Looking for pricing, stock, or lifecycle information?

Click below to explore more details on WIN SOURCE:

 [View LMV716MMX/NOPB on WIN SOURCE](#)

 [Texas Instruments](#) Information

Optimize Your Supply Chain with WIN SOURCE Solutions

-  Global Sourcing Solution
-  Obsolete Management
-  Cost Control Management
-  Shortage Management
-  Alternative Solution
-  Excess Inventory Management