



**THE DATASHEET OF
LMV1091TM/NOPB**



LMV1091 Dual Input, Far Field Noise Suppression Microphone Amplifier

Check for Samples: [LMV1091](#)

FEATURES

- **No Loss of Voice Intelligibility**
- **Low Power Consumption**
- **Shutdown Function**
- **No added Processing Delay**
- **Differential Outputs**
- **Adjustable 12 - 54dB Gain**
- **Excellent RF Immunity**
- **Available in a 25-Bump DSBGA Package**

APPLICATIONS

- **Mobile Headset**
- **Mobile and Handheld Two-way Radios**
- **Bluetooth and Other Powered Headsets**
- **Hand-held Voice Microphones**

KEY SPECIFICATIONS

- **Far Field Noise Suppression Electrical (FFNS_E at f = 1kHz): 34dB (typ)**
- **SNRI_E: 26dB (typ)**
- **Supply Voltage: 2.7V to 5.5V**
- **Supply Current: 600μA (typ)**
- **Standby Current: 0.1μA (typ)**
- **Signal-to-Noise Ratio (Voice band): 65dB (typ)**
- **Total Harmonic Distortion + Noise: 0.1% (typ)**
- **PSRR (217Hz): 99dB (typ)**

DESCRIPTION

The LMV1091 is a fully analog dual differential input, differential output, microphone array amplifier designed to reduce background acoustic noise, while delivering superb speech clarity in voice communication applications.

The LMV1091 preserves near-field voice signals within 4cm of the microphones while rejecting far-field acoustic noise greater than 50cm from the microphones. Up to 20dB of far-field rejection is possible in a properly configured and using ±0.5dB matched microphones.

Part of the Powerwise™ family of energy efficient solutions, the LMV1091 consumes only 600μA of supply current providing superior performance over DSP solutions consuming greater than ten times the power.

The dual microphone inputs and the processed signal output are differential to provide excellent noise immunity. The microphones are biased with an internal low-noise bias supply.



Please be aware that an important notice concerning availability, standard warranty, and use in critical applications of Texas Instruments semiconductor products and disclaimers thereto appears at the end of this data sheet.

All trademarks are the property of their respective owners.

System Diagram

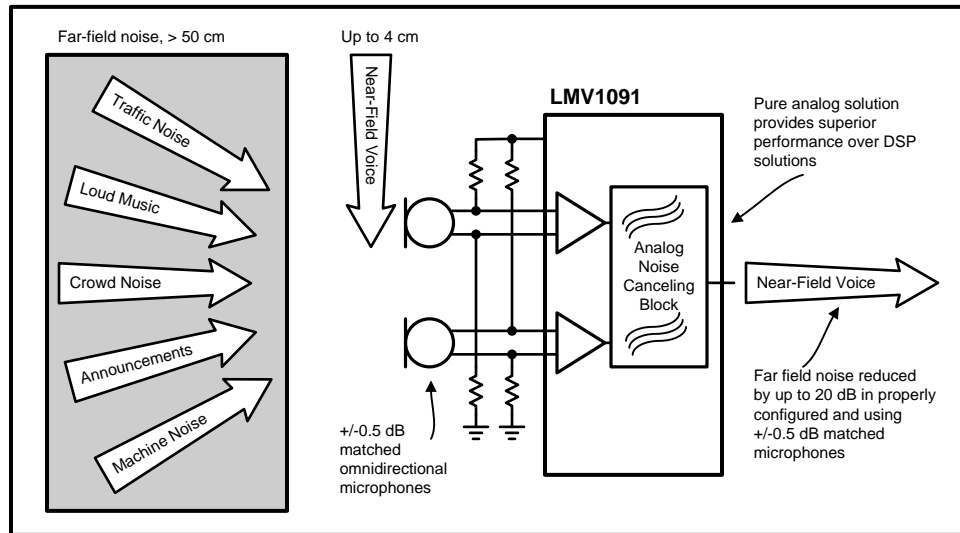

Typical Application

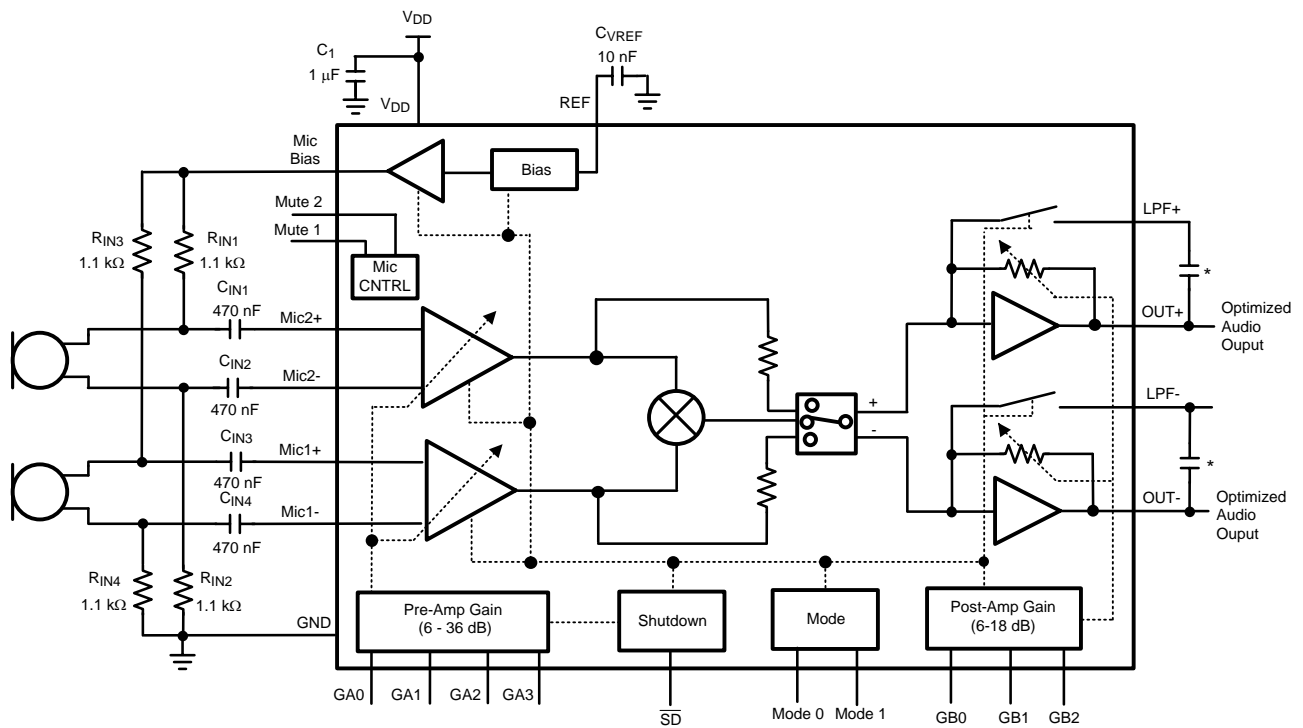

* The value of the low-pass filter capacitor is application dependent, see the application section for additional information.

Figure 1. Typical Dual Microphone Far Field noise Cancelling Application

Connection Diagram

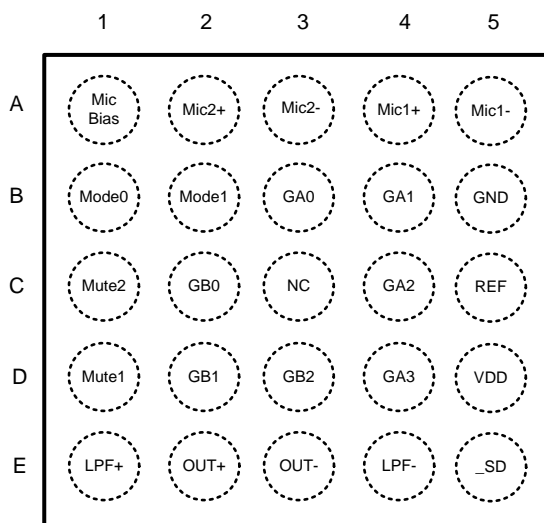

**Figure 2. 25-Bump DSBGA (Top View)
See YFQ0025 Package**

PIN NAME AND FUNCTION

Bump Number	Pin Name	Pin Function	Pin Type
A1	MIC BIAS	Microphone Bias	Analog Output
A2	MIC2+	Microphone 2 positive input	Analog Input
A3	MIC2-	Microphone 2 negative input	Analog Input
A4	MIC1+	Microphone 1 positive input	Analog Input
A5	MIC1-	Microphone 1 negative input	Analog Input
B1	MODE0	Mic mode select pin	Digital Input
B2	MODE1	Mic mode select pin	Digital Input
B3	GA0	Pre-Amplifier Gain select pin	Digital Input
B4	GA1	Pre-Amplifier Gain select pin	Digital Input
B5	GND	Ground	Ground
C1	MUTE2	Mute select pin	Digital Input
C2	GB0	Post-Amplifier Gain select pin	Digital Input
C3	NC	No Connect	
C4	GA2	Pre-Amplifier Gain select pin	Digital Input
C5	REF	Reference voltage de-coupling	Analog Ref
D1	MUTE1	Mute select pin	Digital Input
D2	GB1	Post-Amp Gain select pin	Digital Input
D3	GB2	Post-Amp Gain select pin	Digital Input
D4	GA3	Pre-Amp Gain select pin	Digital Input
D5	VDD	Power Supply	Supply
E1	LPF+	Low pass Filter for positive output	Analog Input
E2	OUT+	Positive optimized audio output	Analog Output
E3	OUT-	Negative optimized audio output	Analog Output
E4	LPF-	Low pass Filter for negative output	Analog Input
E5	$\overline{\text{SD}}$	Chip enable	Digital Input



These devices have limited built-in ESD protection. The leads should be shorted together or the device placed in conductive foam during storage or handling to prevent electrostatic damage to the MOS gates.

Absolute Maximum Ratings⁽¹⁾⁽²⁾

Supply Voltage	6.0V	
Storage Temperature	-85°C to +150°C	
Power Dissipation ⁽³⁾	Internally Limited	
ESD Rating ⁽⁴⁾	2000V	
ESD Rating ⁽⁵⁾	200V	
CDM	500V	
Junction Temperature (T _{JMAX})	150°C	
Mounting Temperature	Infrared or Convection (20 sec.)	235°C
Thermal Resistance	θ _{JA} (DSBGA)	70°C/W
Soldering Information See SNVA009A “microSMD Wafer Level Chip Scale Package.”		

- (1) “*Absolute Maximum Ratings*” indicate limits beyond which damage to the device may occur, including inoperability and degradation of device reliability and/or performance. Functional operation of the device and/or non-degradation at the *Absolute Maximum Ratings* or other conditions beyond those indicated in the *Recommended Operating Conditions* is not implied. The *Recommended Operating Conditions* indicate conditions at which the device is functional and the device should not be operated beyond such conditions. All voltages are measured with respect to the ground pin, unless otherwise specified.
- (2) If Military/Aerospace specified devices are required, please contact the Texas Instruments Sales Office/Distributors for availability and specifications.
- (3) The maximum power dissipation must be de-rated at elevated temperatures and is dictated by T_{JMAX}, θ_{JC}, and the ambient temperature T_A. The maximum allowable power dissipation is P_{DMAX} = (T_{JMAX} – T_A) / θ_{JA} or the number given in the *Absolute Maximum Ratings*, whichever is lower. For the LMV1091, T_{JMAX} = 150°C and the typical θ_{JA} for this DSBGA package is 70°C/W. Refer to the *Thermal Considerations* section for more information.
- (4) Human body model, applicable std. JESD22-A114C.
- (5) Machine model, applicable std. JESD22-A115-A.

Operating Ratings⁽¹⁾

Supply Voltage	2.7V ≤ V _{DD} ≤ 5.5V
T _{MIN} ≤ T _A ≤ T _{MAX}	-40°C ≤ T _A ≤ +85°C

- (1) “*Absolute Maximum Ratings*” indicate limits beyond which damage to the device may occur, including inoperability and degradation of device reliability and/or performance. Functional operation of the device and/or non-degradation at the *Absolute Maximum Ratings* or other conditions beyond those indicated in the *Recommended Operating Conditions* is not implied. The *Recommended Operating Conditions* indicate conditions at which the device is functional and the device should not be operated beyond such conditions. All voltages are measured with respect to the ground pin, unless otherwise specified.

Electrical Characteristics 3.3V⁽¹⁾⁽²⁾

Unless otherwise specified, all limits ensured for T_A = 25°C, V_{DD} = 3.3V, V_{IN} = 18mV_{P-P}, f = 1kHz, \overline{SD} = V_{DD}, Pre Amp gain = 20dB, Post Amp gain = 6dB, R_L = 100kΩ, and C_L = 4.7pF, f = 1kHz pass through mode.

Symbol	Parameter	Conditions	LMV1091		Units (Limits)
			Typical ⁽³⁾	Limits ⁽⁴⁾	
SNR	Signal-to-Noise Ratio	V _{IN} = 18mV _{P-P} , A-weighted, Audio band	63		dB
		V _{OUT} = 18V _{P-P} , voice band (300–3400Hz)	65		dB
e _N	Input Referred Noise level	A-Weighted	5		μV _{RMS}

- (1) “*Absolute Maximum Ratings*” indicate limits beyond which damage to the device may occur, including inoperability and degradation of device reliability and/or performance. Functional operation of the device and/or non-degradation at the *Absolute Maximum Ratings* or other conditions beyond those indicated in the *Recommended Operating Conditions* is not implied. The *Recommended Operating Conditions* indicate conditions at which the device is functional and the device should not be operated beyond such conditions. All voltages are measured with respect to the ground pin, unless otherwise specified.
- (2) The *Electrical Characteristics* tables list ensured specifications under the listed *Recommended Operating Conditions* except as otherwise modified or specified by the *Electrical Characteristics Conditions* and/or Notes. Typical specifications are estimations only and are not ensured.
- (3) Typical values represent most likely parametric norms at T_A = +25°C, and at the *Recommended Operation Conditions* at the time of product characterization and are not ensured.
- (4) Datasheet min/max specification limits are specified by test, or statistical analysis.

Electrical Characteristics 3.3V⁽¹⁾⁽²⁾ (continued)

Unless otherwise specified, all limits ensured for $T_A = 25^\circ\text{C}$, $V_{DD} = 3.3\text{V}$, $V_{IN} = 18\text{mV}_{P-P}$, $f = 1\text{kHz}$, $\overline{SD} = V_{DD}$, Pre Amp gain = 20dB, Post Amp gain = 6dB, $R_L = 100\text{k}\Omega$, and $C_L = 4.7\text{pF}$, $f = 1\text{kHz}$ pass through mode.

V_{IN}	Maximum Input Signal	THD+N < 1%, Pre Amp Gain = 6dB	880	820	mV_{P-P} (min)
V_{OUT}	Maximum AC Output Voltage	Differential Out+, Out- THD+N < 1%	1.2	1.1	V_{RMS} (min)
	DC Level at Outputs	Out+, Out-	820		mV
THD+N	Total Harmonic Distortion + Noise	Differential Out+ and Out-	0.1	0.2	% (max)
Z_{IN}	Input Impedance		142		$\text{k}\Omega$
Z_{OUT}	Output Impedance		220		Ω
Z_{LOAD}	Load Impedance (Out+, Out-) ⁽⁵⁾	R_{LOAD} C_{LOAD}		10 100	$\text{k}\Omega$ (min) pF (max)
A_M	Microphone Preamp Gain Range	Minimum	6		dB
		Maximum	36		dB
A_{MR}	Microphone Preamp Gain Adjustment Resolution		2	1.7 2.3	dB (min) dB (max)
A_P	Post Amplifier Gain Range	Minimum	6		dB
		Maximum	18		dB
A_{PR}	Post Amplifier Gain Resolution		3	2.6 3.4	dB (min) dB (max)
FFNS _E	Far Field Noise Suppression Electrical	$f = 1\text{kHz}$ (See Test Methods)	34	26	dB
		$f = 300\text{Hz}$ (See Test Methods)	42		
SNRI _E	Signal-to-Noise Ratio Improvement Electrical	$f = 1\text{kHz}$ (See Test Methods)	26	18	dB
		$f = 300\text{Hz}$ (See Test Methods)	33		
PSRR	Power Supply Rejection Ratio	Input Referred, Input AC grounded			
		$f_{RIPPLE} = 217\text{Hz}$ ($V_{RIPPLE} = 100\text{mV}_{P-P}$)	99	85	dB (min)
		$f_{RIPPLE} = 1\text{kHz}$ ($V_{RIPPLE} = 100\text{mV}_{P-P}$)	95	80	dB (min)
CMRR	Common Mode Rejection Ratio	Input referred	60		dB
V_{BM}	Microphone Bias Supply Voltage	$I_{BIAS} = 1.2\text{mA}$	2.0	1.85 2.15	V (min) V (max)
e_{VBM}	Mic bias noise voltage on V_{REF} pin	A-Weighted, $C_B = 10\text{nF}$	7		μV_{RMS}
I_{DDQ}	Supply Quiescent Current	$V_{IN} = 0\text{V}$	0.60	0.8	mA (max)
I_{DD}	Supply Current	$V_{IN} = 25\text{mV}_{P-P}$ both inputs Noise cancelling mode	0.60		mA
I_{SD}	Shut Down Current	\overline{SD} pin = GND	0.1	0.7	μA (max)
T_{ON}	Turn-On Time ⁽⁶⁾			40	ms (max)
T_{OFF}	Turn-Off Time ⁽⁶⁾			60	ms (max)
V_{IH}	Logic High Input Threshold	GA0, GA1, GA2, GA3, GB0, GB1, GB2, Mute1, Mute2, Mode 0, Mode 1, \overline{SD}		1.4	V (min)
V_{IL}	Logic Low Input Threshold	GA0, GA1, GA2, GA3, GB0, GB1, GB2, Mute1, Mute2, Mode 0, Mode 1, \overline{SD}		0.4	V (max)

(5) Specified by design.

(6) Specified by design.

Electrical Characteristics 5.0V⁽¹⁾

Unless otherwise specified, all limits ensured for $T_A = 25^\circ\text{C}$, $V_{DD} = 5\text{V}$, $V_{IN} = 18\text{mV}_{P-P}$, $\overline{SD} = V_{DD}$, Pre Amp gain = 20dB, Post Amp gain = 6dB, $R_L = 100\text{k}\Omega$, and $C_L = 4.7\text{pF}$, $f = 1\text{kHz}$ pass through mode.

Symbol	Parameter	Conditions	LMV1091		Units (Limits)
			Typical ⁽²⁾	Limit ⁽³⁾	
SNR	Signal-to-Noise Ratio	$V_{IN} = 18\text{mV}_{P-P}$, A-weighted, Audio band	63		dB
		$V_{OUT} = 18\text{mV}_{P-P}$, voice band (300–3400Hz)	65		dB
e_N	Input Referred Noise level	A-Weighted	5		μV_{RMS}
V_{IN}	Maximum Input Signal	THD+N < 1%	880	820	mV_{P-P} (min)
V_{OUT}	Maximum AC Output Voltage	$f = 1\text{kHz}$, THD+N < 1% between differential output	1.2	1.1	V_{RMS} (min)
	DC Output Voltage		820		mV
THD+N	Total Harmonic Distortion + Noise	Differential Out+ and Out-	0.1	0.2	% (max)
Z_{IN}	Input Impedance		142		$\text{k}\Omega$
Z_{OUT}	Output Impedance		220		Ω
A_M	Microphone Preamplifier Gain Range	Minimum	6		dB
		Maximum	36		dB
A_{MR}	Microphone Preamplifier Gain Adjustment Resolution		2	1.7 2.3	dB (min) dB (max)
A_P	Post Amplifier Gain Range	Minimum	6		dB
		Maximum	18		dB
A_{PR}	Post Amplifier Gain Adjustment Resolution		3	2.6 3.4	dB (min) dB (max)
FFNS _E	Far Field Noise Suppression Electrical	$f = 1\text{kHz}$ (See Test Methods)	34	26	dB
		$f = 300\text{Hz}$ (See Test Methods)	42		
SNRI _E	Signal-to-Noise Ratio Improvement Electrical	$f = 1\text{kHz}$ (See Test Methods)	26	18	dB
		$f = 300\text{Hz}$ (See Test Methods)	33		
PSRR	Power Supply Rejection Ratio	Input Referred, Input AC grounded			
		$f_{RIPPLE} = 217\text{Hz}$ ($V_{RIPPLE} = 100\text{mV}_{P-P}$)	99	85	dB (min)
		$f_{RIPPLE} = 1\text{kHz}$ ($V_{RIPPLE} = 100\text{mV}_{P-P}$)	95	80	dB (min)
CMRR	Common Mode Rejection Ratio	Input referred	60		dB
V_{BM}	Microphone Bias Supply Voltage	$I_{BIAS} = 1.2\text{mA}$	2.0	1.85 2.15	V (min) V (max)
e_{VBM}	Microphone bias noise voltage on V_{REF} pin	A-Weighted, $C_B = 10\text{nF}$	7		μV_{RMS}
I_{DDQ}	Supply Quiescent Current	$V_{IN} = 0\text{V}$	0.60	0.8	mA (max)
I_{DD}	Supply Current	$V_{IN} = 25\text{mV}_{P-P}$ both inputs Noise cancelling mode	0.60		mA
I_{SD}	Shut Down Current	\overline{SD} pin = GND	0.1		μA
T_{ON}	Turn On Time			40	ms (max)
T_{OFF}	Turn Off Time			60	ms (max)
V_{IH}	Logic High Input Threshold	GA0, GA1, GA2, GA3, GB0, GB1, GB2, Mute1, Mute2, Mode 0, Mode 1, \overline{SD}		1.4	V (min)
V_{IL}	Logic Low Input Threshold	GA0, GA1, GA2, GA3, GB0, GB1, GB2, Mute1, Mute2, Mode 0, Mode 1, \overline{SD}		0.4	V (max)

- (1) "Absolute Maximum Ratings" indicate limits beyond which damage to the device may occur, including inoperability and degradation of device reliability and/or performance. Functional operation of the device and/or non-degradation at the Absolute Maximum Ratings or other conditions beyond those indicated in the Recommended Operating Conditions is not implied. The Recommended Operating Conditions indicate conditions at which the device is functional and the device should not be operated beyond such conditions. All voltages are measured with respect to the ground pin, unless otherwise specified.
- (2) Typical values represent most likely parametric norms at $T_A = +25^\circ\text{C}$, and at the Recommended Operation Conditions at the time of product characterization and are not ensured.
- (3) Datasheet min/max specification limits are specified by test, or statistical analysis.

Test Methods

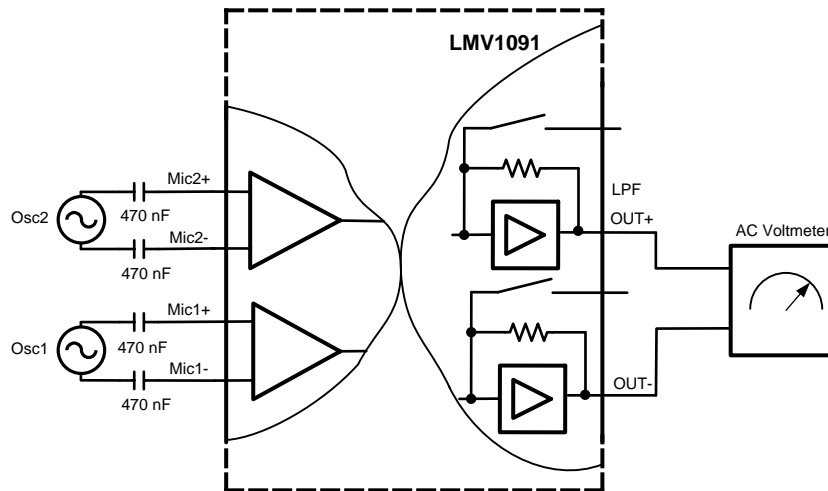

Figure 3. $FFNS_E$, $NFSL_E$, $SNRI_E$ Test Circuit

FAR FIELD NOISE SUPPRESSION ($FFNS_E$)

For optimum noise suppression the far field noise should be in a broadside array configuration from the two microphones (see Figure 20). Which means the far field sound source is equidistance from the two microphones. This configuration allows the amplitude of the far field signal to be equal at the two microphone inputs, however a slight phase difference may still exist. To simulate a real world application a slight phase delay was added to the $FFNS_E$ test. The block diagram from Figure 18 is used with the following procedure to measure the $FFNS_E$.

1. A sine wave with equal frequency and amplitude ($25mV_{P-P}$) is applied to Mic1 and Mic2. Using a signal generator, the phase of Mic 2 is delayed by 1.1° when compared with Mic1.
2. Measure the output level in dBV (X)
3. Mute the signal from Mic2
4. Measure the output level in dBV (Y)
5. $FFNS_E = Y - X$ dB

NEAR FIELD SPEECH LOSS ($NFSL_E$)

For optimum near field speech preservation, the sound source should be in an endfire array configuration from the two microphones (see Figure 21). In this configuration the speech signal at the microphone closest to the sound source will have greater amplitude than the microphone further away. Additionally the signal at microphone further away will experience a phase lag when compared with the closer microphone. To simulate this, phase delay as well as amplitude shift was added to the $NFSL_E$ test. The schematic from Figure 18 is used with the following procedure to measure the $NFSL_E$.

1. A $25mV_{P-P}$ and $17.25mV_{P-P}$ ($0.69 * 25mV_{P-P}$) sine wave is applied to Mic1 and Mic2 respectively. Once again, a signal generator is used to delay the phase of Mic2 by 15.9° when compared with Mic1.
2. Measure the output level in dBV (X)
3. Mute the signal from Mic2
4. Measure the output level in dBV (Y)
5. $NFSL_E = Y - X$ dB

SIGNAL TO NOISE RATIO IMPROVEMENT ELECTRICAL ($SNRI_E$)

The $SNRI_E$ is the ratio of $FFNS_E$ to $NFSL_E$ and is defined as:

$$SNRI_E = FFNS_E - NFSL_E$$

Measuring Noise and SNR

The overall noise of the LMV1091 is measured within the frequency band from 10Hz to 22kHz using an A-weighted filter. The Mic+ and Mic- inputs of the LMV1091 are AC shorted between the input capacitors, see Figure 4.

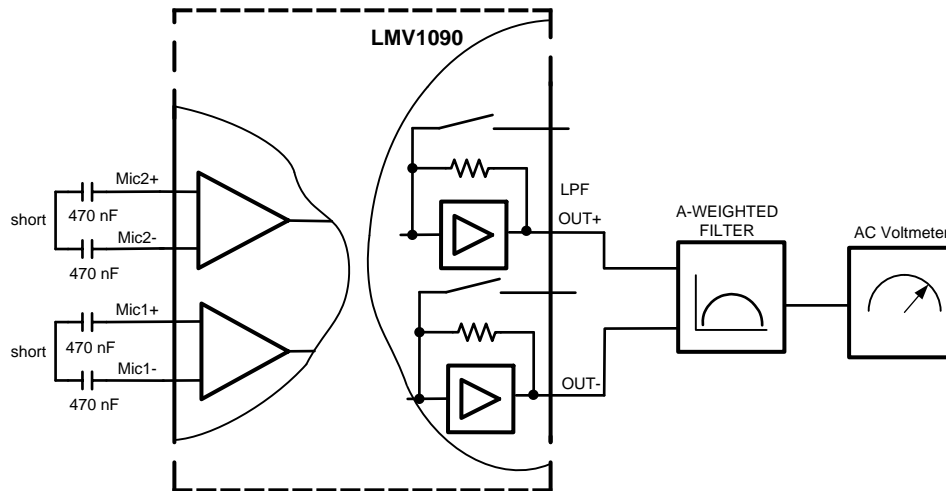

Figure 4. Noise Measurement Setup

For the signal to noise ratio (SNR) the signal level at the output is measured with a 1kHz input signal of 18mV_{p-p} using an A-weighted filter. This voltage represents the output voltage of a typical electret condenser microphone at a sound pressure level of 94dB SPL, which is the standard level for these measurements. The LMV1091 is programmed for 26dB of total gain (20dB preamplifier and 6dB postamplifier) with only Mic1 or Mic2 used.

The input signal is applied differentially between the Mic+ and Mic-. Because the part is in Pass Through mode the low-pass filter at the output of the LMV1091 is disabled.

Typical Performance Characteristics

Unless otherwise specified, $T_J = 25^\circ\text{C}$, $V_{DD} = 3.3\text{V}$, Input Voltage = $18\text{mV}_{\text{p-p}}$, $f = 1\text{kHz}$, pass through mode, Pre Amp gain = 20dB, Post Amp gain = 6dB, $R_L = 100\text{k}\Omega$, and $C_L = 4.7\text{pF}$.

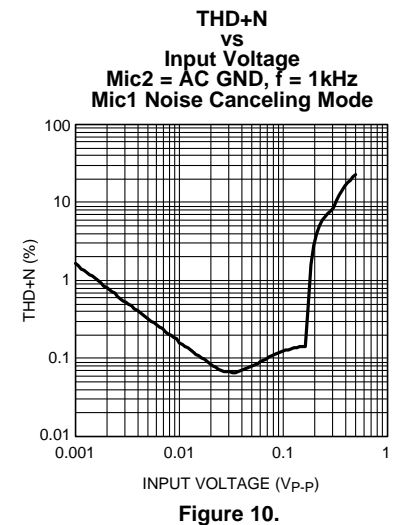
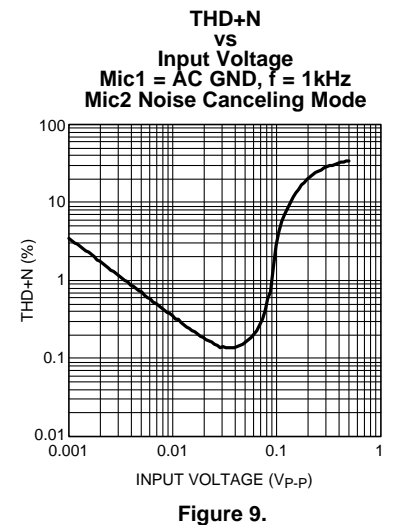
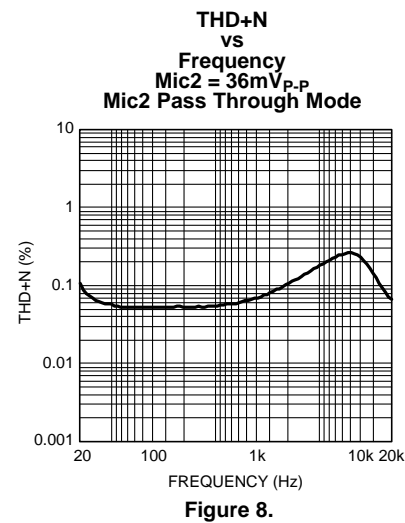
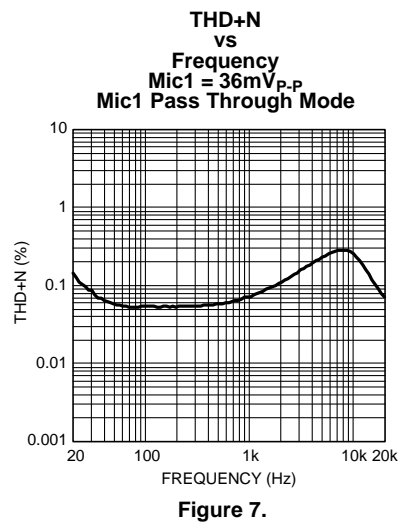
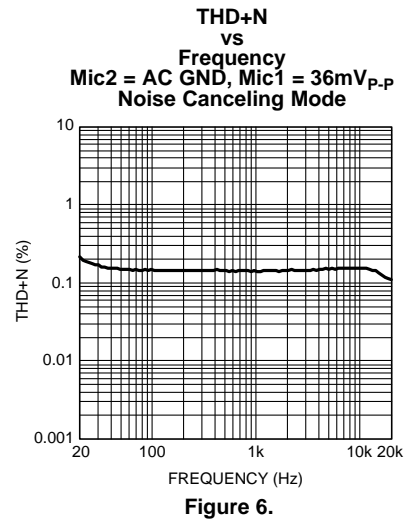
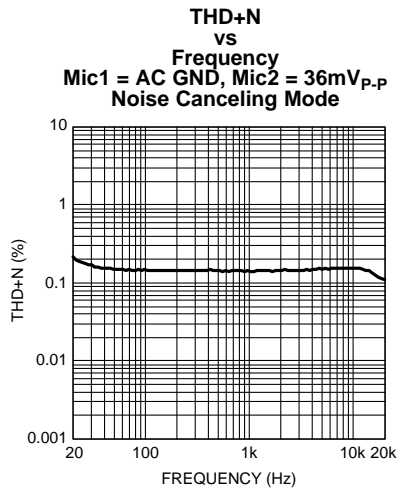

Typical Performance Characteristics (continued)

Unless otherwise specified, $T_J = 25^\circ\text{C}$, $V_{DD} = 3.3\text{V}$, Input Voltage = $18\text{mV}_{p,p}$, $f = 1\text{kHz}$, pass through mode, Pre Amp gain = 20dB , Post Amp gain = 6dB , $R_L = 100\text{k}\Omega$, and $C_L = 4.7\text{pF}$.

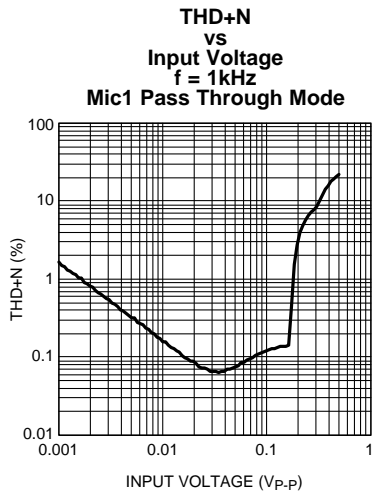

Figure 11.

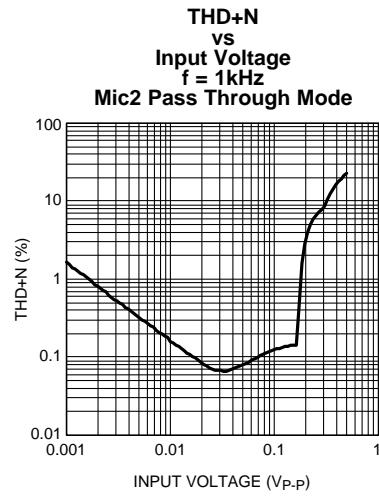

Figure 12.

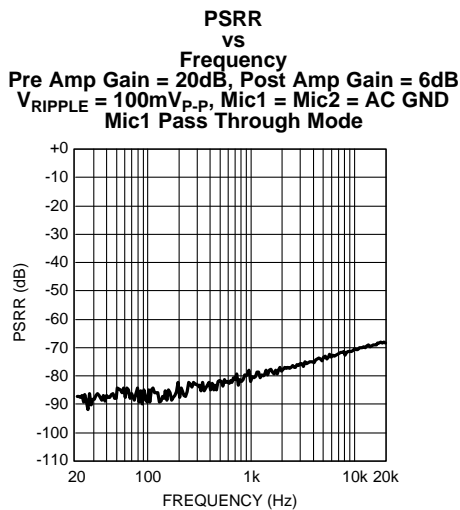

Figure 13.

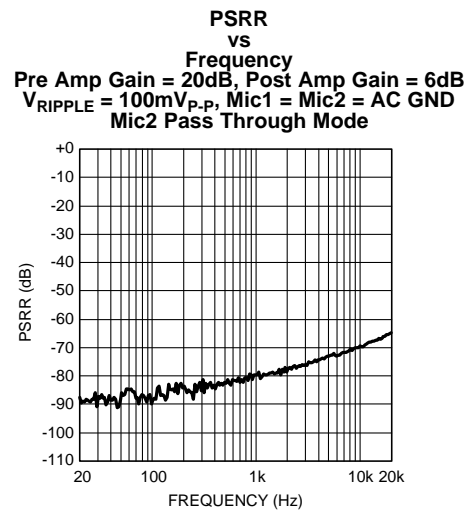

Figure 14.

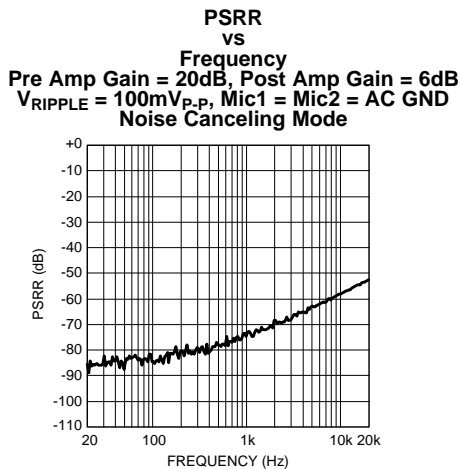

Figure 15.

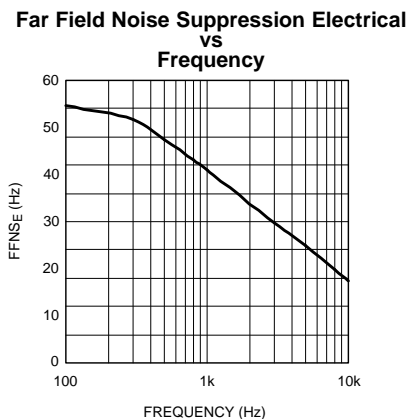

Figure 16.

Typical Performance Characteristics (continued)

Unless otherwise specified, $T_J = 25^\circ\text{C}$, $V_{DD} = 3.3\text{V}$, Input Voltage = $18\text{mV}_{\text{p-p}}$, $f = 1\text{kHz}$, pass through mode, Pre Amp gain = 20dB , Post Amp gain = 6dB , $R_L = 100\text{k}\Omega$, and $C_L = 4.7\text{pF}$.

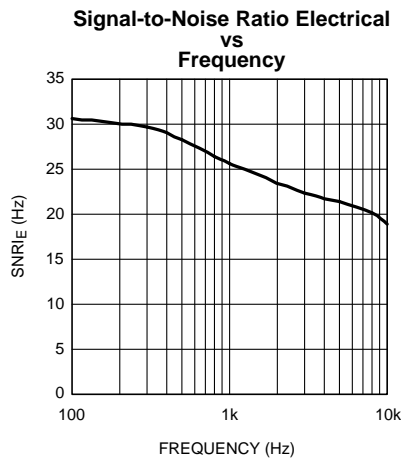

Figure 17.

APPLICATION DATA

INTRODUCTION

The LMV1091 is a fully analog single chip solution to reduce the far field noise picked up by microphones in a communication system. A simplified block diagram is provided in [Figure 18](#).

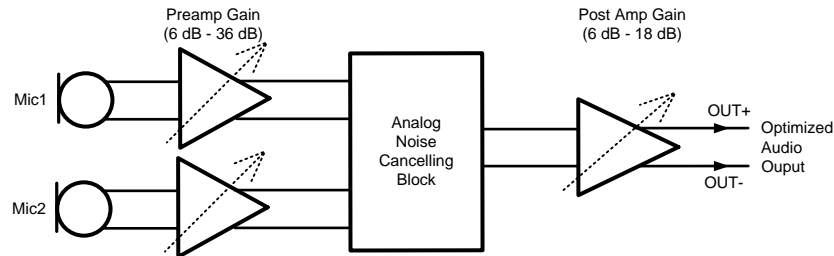

Figure 18. Simplified Block Diagram of the LMV1091

The output signal of the microphones is amplified by a pre-amplifier with adjustable gain between 6dB and 36dB. After the signals are matched the analog noise cancelling suppresses the far field noise signal. The output of the analog noise cancelling processor is amplified in the post amplifier with adjustable gain between 6dB and 18dB. For optimum noise and EMI immunity, the microphones have a differential connection to the LMV1091 and the output of the LMV1091 is also differential. The adjustable gain functions can be controlled via GA0–GA3 and GB0–GB2 pins.

Power Supply Circuits

A low drop-out (LDO) voltage regulator in the LMV1091 allows the device to be independent of supply voltage variations.

The Power On Reset (POR) circuitry in the LMV1091 requires the supply voltage to rise from 0V to V_{DD} in less than 100ms.

The Mic Bias output is provided as a low noise supply source for the electret microphones. The noise voltage on the Mic Bias microphone supply output pin depends on the noise voltage on the internal the reference node. The de-coupling capacitor on the V_{REF} pin determines the noise voltage on this internal reference. This capacitor should be larger than 1nF; having a larger capacitor value will result in a lower noise voltage on the Mic Bias output.

Gain Balance and Gain Budget

In systems where input signals have a high dynamic range, critical noise levels or where the dynamic range of the output voltage is also limited, careful gain balancing is essential for the best performance. Too low of a gain setting in the preamplifier can result in higher noise levels while too high of a gain setting in the preamplifier will result in clipping and saturation in the noise cancelling processor and output stages.

The gain ranges and maximum signal levels for the different functional blocks are shown in [Figure 19](#). Two examples are given as a guideline on how to select proper gain settings.

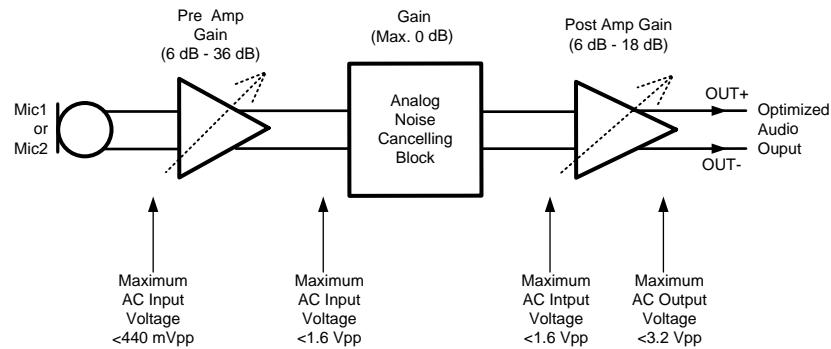

Figure 19. Maximum Signal Levels

Example 1

An application using microphones with $50\text{mV}_{\text{P-P}}$ maximum output voltage, and a baseband chip after the LMV1091 with $1.5\text{V}_{\text{P-P}}$ maximum input voltage.

For optimum noise performance, the gain of the input stage should be set to the maximum.

- $50\text{mV}_{\text{P-P}} + 36\text{dB} = 3.1\text{V}_{\text{P-P}}$.
- $3.1\text{V}_{\text{P-P}}$ is higher than the maximum $1.5\text{V}_{\text{P-P}}$ allowed for the Noise Cancelling Block (NCB). This means a gain lower than 29.5dB should be selected.
- Select the nearest lower gain from the gain settings shown in Table 1, 28dB is selected. This will prevent the NCB from being overloaded by the microphone. With this setting, the resulting output level of the Pre Amplifier will be $1.26\text{V}_{\text{P-P}}$.
- The NCB has a gain of 0dB which will result in $1.26\text{V}_{\text{P-P}}$ at the output of the LMV1091. This level is less than maximum level that is allowed at the input of the post amp of the LMV1091.
- The baseband chip limits the maximum output voltage to $1.5\text{V}_{\text{P-P}}$ with the minimum of 6dB post amp gain, this results in requiring a lower level at the input of the post amp of $0.75\text{V}_{\text{P-P}}$. Now calculating this for a maximum preamp gain, the output of the preamp must be no more than $0.75\text{mV}_{\text{P-P}}$.
- Calculating the new gain for the preamp will result in <math><23.5\text{dB}</math> gain.
- The nearest lower gain will be 22dB.

So using preamp gain = 22dB and postamp gain = 6dB is the optimum for this application.

Example 2

An application using microphones with $10\text{mV}_{\text{P-P}}$ maximum output voltage, and a baseband chip after the LMV1091 with $3.3\text{V}_{\text{P-P}}$ maximum input voltage.

For optimum noise performance we would like to have the maximum gain at the input stage.

- $10\text{mV}_{\text{P-P}} + 36\text{dB} = 631\text{mV}_{\text{P-P}}$.
- This is lower than the maximum $1.5\text{V}_{\text{P-P}}$, so this is OK.
- The NCB has a gain of 0dB which will result in $1.5\text{V}_{\text{P-P}}$ at the output of the LMV1091. This level is lower than the maximum level that is allowed at the input of the Post Amp of the LMV1091.
- With a Post Amp gain setting of 6dB the output of the Post Amp will be $3\text{V}_{\text{P-P}}$ which is OK for the baseband.
- The nearest lower Post Amp gain will be 6dB.

So using preamp gain = 36dB and postamp gain = 6dB is optimum for this application.

Pre-Amp/Post-Amp Gains

The Pre-amplifier gain of the LMV1091TM can be controlled using the GA0-GA3 pins. See Table 1 below for Pre-amplifier gain control. The Post-Amp gain can be controlled using the GB0-GB2 pins. See Table 2 below for Post-amplifier gain control.

Table 1. Mic Pre-Amp Gain Settings

GA3	GA2	GA1	GA0	Pre-Amplifier Gain
0	0	0	0	6dB
0	0	0	1	8dB
0	0	1	0	10dB
0	0	1	1	12dB
0	1	0	0	14dB
0	1	0	1	16dB
0	1	1	0	18dB
0	1	1	1	20dB
1	0	0	0	22dB
1	0	0	1	24dB
1	0	1	0	26dB
1	0	1	1	28dB
1	1	0	0	30dB
1	1	0	1	32dB
1	1	1	0	34dB
1	1	1	1	36dB

Table 2. Post-Amp Gain Settings

GB2	GB1	GB0	Post-Amplifier Gain
0	0	0	6dB
0	0	1	9dB
0	1	0	12dB
0	1	1	15dB
1	0	0	18dB
1	0	1	18dB
1	1	0	18dB
1	1	1	18dB

Noise Reduction Mode Settings

The LMV1091TM has four mode settings. It can be placed in noise cancellation mode, mic 1 on with mic 2 off, mic 1 off with mic 2 on, and mic1 and mic2. See [Table 3](#) for control settings.

Table 3. Noise Reduction Mode Settings

Mode 1	Mode 0	Noise Reduction Mode Selection
0	0	Noise cancelling mode
0	1	Only Mic 1 On
1	0	Only Mic 2 On
1	1	Mic 1 + Mic 2

Mute Section

Mic 1 and Mic 2 can be muted independently, using the Mute 1 and Mute 2 pins. See [Table 4](#) for control settings.

Table 4. Noise Reduction Mode Settings

Mute 2	Mute 1	Mute Mode Selection
0	0	Mic 1 and Mic 2 on
0	1	Mic 1 mute
1	0	Mic 2 mute
1	1	Mic 1 and Mic 2 mute

Microphone Placement

Because the LMV1091 is a microphone array Far Field Noise Reduction solution, proper microphone placement is critical for optimum performance. Two things need to be considered: The spacing between the two microphones and the position of the two microphones relative to near field source

If the spacing between the two microphones is too small near field speech will be canceled along with the far field noise. Conversely, if the spacing between the two microphones is large, the far field noise reduction performance will be degraded. The optimum spacing between Mic 1 and Mic 2 is 1.5-2.5cm. This range provides a balance of minimal near field speech loss and maximum far field noise reduction. The microphones should be in line with the desired sound source 'near speech' and configured in an endfire array (see Figure 21) orientation from the sound source. If the 'near speech' (desired sound source) is equidistant to the source like a broadside array (see Figure 20) the result will be a great deal of near field speech loss.

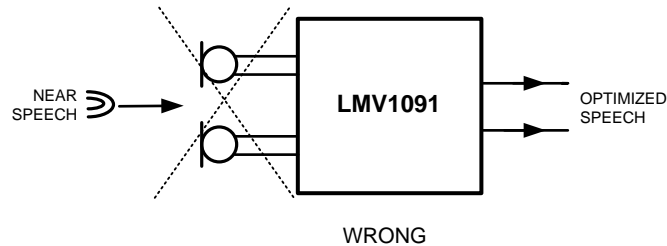

Figure 20. Broadside Array (WRONG)

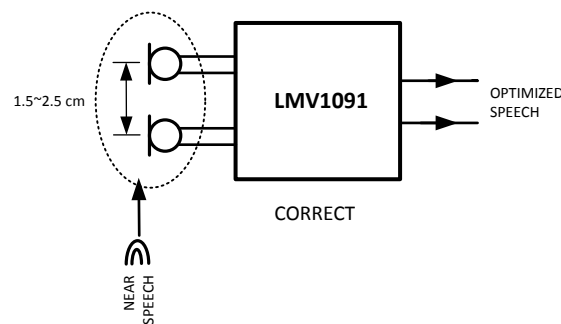

Figure 21. Endfire Array (CORRECT)

Low-Pass Filter At The Output

At the output of the LMV1091 there is a provision to create a 1st order low-pass filter (only enabled in 'Noise Cancelling' mode). This low-pass filter can be used to compensate for the change in frequency response that results from the noise cancellation process. The change in frequency response resembles a first-order high-pass filter, and for many of the applications it can be compensated by a first-order low-pass filter with cutoff frequency between 1.5kHz and 2.5kHz.

The transfer function of the low-pass filter is derived as:

$$H(s) = \frac{\text{Post Amplifier gain}}{sR_f C_f + 1} \quad (1)$$

This low-pass filter is created by connecting a capacitor between the LPF pin and the OUT pin of the LMV1091. The value of this capacitor also depends on the selected output gain. For different gains the feedback resistance in the low-pass filter network changes as shown in [Table 5](#).

This will result in the following values for a cutoff frequency of 2000 Hz:

Table 5. Low-Pass Filter Capacitor For 2kHz

Post Amplifier Gain Setting (dB)	R _f (kΩ)	C _f (nF)
6	20	3.9
9	29	2.7
12	40	2.0
15	57	1.3
18	80	1.0

A-Weighted Filter

The human ear is sensitive for acoustic signals within a frequency range from about 20Hz to 20kHz. Within this range the sensitivity of the human ear is not equal for each frequency. To approach the hearing response, weighting filters are introduced. One of those filters is the A-weighted filter.

The A-weighted filter is used in signal to noise measurements, where the wanted audio signal is compared to device noise and distortion.

The use of this filter improves the correlation of the measured values to the way these ratios are perceived by the human ear.

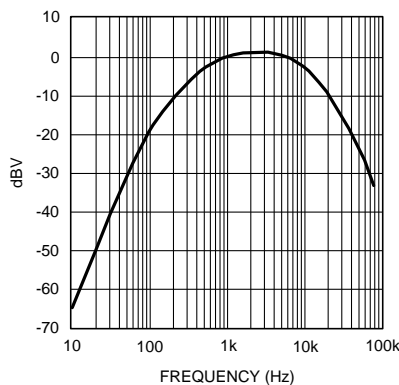

Figure 22. A-Weighted Filter

Table 6. Revision History

Rev	Date	Description
1.0	10/28/09	Initial released.
1.01	05/17/10	Changed the unit measure of the X1, X2, and X3 (under the Physical Dimension) from mm to μm .
1.02	01/13/11	Fixed typos on Figure 1 (Typical Application diagram).
C	05/02/13	Changed layout of National Data Sheet to TI format

PACKAGING INFORMATION

Orderable Device	Status (1)	Package Type	Package Drawing	Pins	Package Qty	Eco Plan (2)	Lead/Ball Finish (6)	MSL Peak Temp (3)	Op Temp (°C)	Device Marking (4/5)	Samples
LMV1091TM/NOPB	ACTIVE	DSBGA	YFQ	25	250	Green (RoHS & no Sb/Br)	SNAGCU	Level-1-260C-UNLIM	-40 to 85	ZA4	Samples
LMV1091TMX/NOPB	ACTIVE	DSBGA	YFQ	25	3000	Green (RoHS & no Sb/Br)	SNAGCU	Level-1-260C-UNLIM	-40 to 85	ZA4	Samples

(1) The marketing status values are defined as follows:

ACTIVE: Product device recommended for new designs.

LIFEBUY: TI has announced that the device will be discontinued, and a lifetime-buy period is in effect.

NRND: Not recommended for new designs. Device is in production to support existing customers, but TI does not recommend using this part in a new design.

PREVIEW: Device has been announced but is not in production. Samples may or may not be available.

OBsolete: TI has discontinued the production of the device.

(2) **RoHS:** TI defines "RoHS" to mean semiconductor products that are compliant with the current EU RoHS requirements for all 10 RoHS substances, including the requirement that RoHS substance do not exceed 0.1% by weight in homogeneous materials. Where designed to be soldered at high temperatures, "RoHS" products are suitable for use in specified lead-free processes. TI may reference these types of products as "Pb-Free".

RoHS Exempt: TI defines "RoHS Exempt" to mean products that contain lead but are compliant with EU RoHS pursuant to a specific EU RoHS exemption.

Green: TI defines "Green" to mean the content of Chlorine (Cl) and Bromine (Br) based flame retardants meet JS709B low halogen requirements of <=1000ppm threshold. Antimony trioxide based flame retardants must also meet the <=1000ppm threshold requirement.

(3) MSL, Peak Temp. - The Moisture Sensitivity Level rating according to the JEDEC industry standard classifications, and peak solder temperature.

(4) There may be additional marking, which relates to the logo, the lot trace code information, or the environmental category on the device.

(5) Multiple Device Markings will be inside parentheses. Only one Device Marking contained in parentheses and separated by a "-" will appear on a device. If a line is indented then it is a continuation of the previous line and the two combined represent the entire Device Marking for that device.

(6) Lead/Ball Finish - Orderable Devices may have multiple material finish options. Finish options are separated by a vertical ruled line. Lead/Ball Finish values may wrap to two lines if the finish value exceeds the maximum column width.

Important Information and Disclaimer:The information provided on this page represents TI's knowledge and belief as of the date that it is provided. TI bases its knowledge and belief on information provided by third parties, and makes no representation or warranty as to the accuracy of such information. Efforts are underway to better integrate information from third parties. TI has taken and continues to take reasonable steps to provide representative and accurate information but may not have conducted destructive testing or chemical analysis on incoming materials and chemicals. TI and TI suppliers consider certain information to be proprietary, and thus CAS numbers and other limited information may not be available for release.

In no event shall TI's liability arising out of such information exceed the total purchase price of the TI part(s) at issue in this document sold by TI to Customer on an annual basis.

TAPE AND REEL INFORMATION



QUADRANT ASSIGNMENTS FOR PIN 1 ORIENTATION IN TAPE



*All dimensions are nominal

Device	Package Type	Package Drawing	Pins	SPQ	Reel Diameter (mm)	Reel Width W1 (mm)	A0 (mm)	B0 (mm)	K0 (mm)	P1 (mm)	W (mm)	Pin1 Quadrant
LMV1091TM/NOPB	DSBGA	YFQ	25	250	178.0	8.4	2.18	2.18	0.76	4.0	8.0	Q1
LMV1091TMX/NOPB	DSBGA	YFQ	25	3000	178.0	8.4	2.18	2.18	0.76	4.0	8.0	Q1

TAPE AND REEL BOX DIMENSIONS

*All dimensions are nominal

Device	Package Type	Package Drawing	Pins	SPQ	Length (mm)	Width (mm)	Height (mm)
LMV1091TM/NOPB	DSBGA	YFQ	25	250	210.0	185.0	35.0
LMV1091TMX/NOPB	DSBGA	YFQ	25	3000	210.0	185.0	35.0

YFQ0025

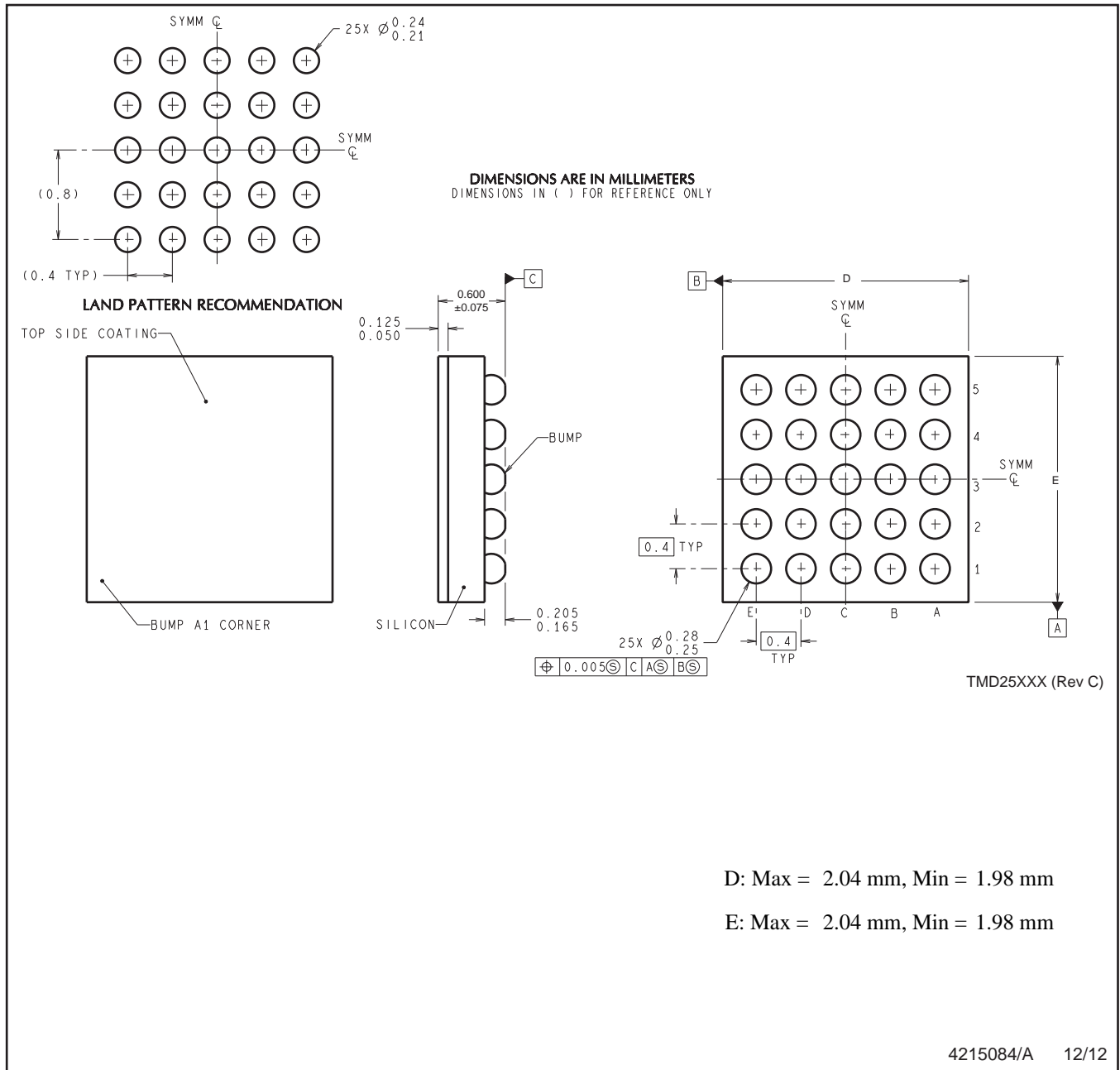

NOTES: A. All linear dimensions are in millimeters. Dimensioning and tolerancing per ASME Y14.5M-1994.
B. This drawing is subject to change without notice.

IMPORTANT NOTICE

Texas Instruments Incorporated (TI) reserves the right to make corrections, enhancements, improvements and other changes to its semiconductor products and services per JESD46, latest issue, and to discontinue any product or service per JESD48, latest issue. Buyers should obtain the latest relevant information before placing orders and should verify that such information is current and complete.

TI's published terms of sale for semiconductor products (<http://www.ti.com/sc/docs/stdterms.htm>) apply to the sale of packaged integrated circuit products that TI has qualified and released to market. Additional terms may apply to the use or sale of other types of TI products and services.

Reproduction of significant portions of TI information in TI data sheets is permissible only if reproduction is without alteration and is accompanied by all associated warranties, conditions, limitations, and notices. TI is not responsible or liable for such reproduced documentation. Information of third parties may be subject to additional restrictions. Resale of TI products or services with statements different from or beyond the parameters stated by TI for that product or service voids all express and any implied warranties for the associated TI product or service and is an unfair and deceptive business practice. TI is not responsible or liable for any such statements.

Buyers and others who are developing systems that incorporate TI products (collectively, "Designers") understand and agree that Designers remain responsible for using their independent analysis, evaluation and judgment in designing their applications and that Designers have full and exclusive responsibility to assure the safety of Designers' applications and compliance of their applications (and of all TI products used in or for Designers' applications) with all applicable regulations, laws and other applicable requirements. Designer represents that, with respect to their applications, Designer has all the necessary expertise to create and implement safeguards that (1) anticipate dangerous consequences of failures, (2) monitor failures and their consequences, and (3) lessen the likelihood of failures that might cause harm and take appropriate actions. Designer agrees that prior to using or distributing any applications that include TI products, Designer will thoroughly test such applications and the functionality of such TI products as used in such applications.

TI's provision of technical, application or other design advice, quality characterization, reliability data or other services or information, including, but not limited to, reference designs and materials relating to evaluation modules, (collectively, "TI Resources") are intended to assist designers who are developing applications that incorporate TI products; by downloading, accessing or using TI Resources in any way, Designer (individually or, if Designer is acting on behalf of a company, Designer's company) agrees to use any particular TI Resource solely for this purpose and subject to the terms of this Notice.

TI's provision of TI Resources does not expand or otherwise alter TI's applicable published warranties or warranty disclaimers for TI products, and no additional obligations or liabilities arise from TI providing such TI Resources. TI reserves the right to make corrections, enhancements, improvements and other changes to its TI Resources. TI has not conducted any testing other than that specifically described in the published documentation for a particular TI Resource.

Designer is authorized to use, copy and modify any individual TI Resource only in connection with the development of applications that include the TI product(s) identified in such TI Resource. NO OTHER LICENSE, EXPRESS OR IMPLIED, BY ESTOPPEL OR OTHERWISE TO ANY OTHER TI INTELLECTUAL PROPERTY RIGHT, AND NO LICENSE TO ANY TECHNOLOGY OR INTELLECTUAL PROPERTY RIGHT OF TI OR ANY THIRD PARTY IS GRANTED HEREIN, including but not limited to any patent right, copyright, mask work right, or other intellectual property right relating to any combination, machine, or process in which TI products or services are used. Information regarding or referencing third-party products or services does not constitute a license to use such products or services, or a warranty or endorsement thereof. Use of TI Resources may require a license from a third party under the patents or other intellectual property of the third party, or a license from TI under the patents or other intellectual property of TI.

TI RESOURCES ARE PROVIDED "AS IS" AND WITH ALL FAULTS. TI DISCLAIMS ALL OTHER WARRANTIES OR REPRESENTATIONS, EXPRESS OR IMPLIED, REGARDING RESOURCES OR USE THEREOF, INCLUDING BUT NOT LIMITED TO ACCURACY OR COMPLETENESS, TITLE, ANY EPIDEMIC FAILURE WARRANTY AND ANY IMPLIED WARRANTIES OF MERCHANTABILITY, FITNESS FOR A PARTICULAR PURPOSE, AND NON-INFRINGEMENT OF ANY THIRD PARTY INTELLECTUAL PROPERTY RIGHTS. TI SHALL NOT BE LIABLE FOR AND SHALL NOT DEFEND OR INDEMNIFY DESIGNER AGAINST ANY CLAIM, INCLUDING BUT NOT LIMITED TO ANY INFRINGEMENT CLAIM THAT RELATES TO OR IS BASED ON ANY COMBINATION OF PRODUCTS EVEN IF DESCRIBED IN TI RESOURCES OR OTHERWISE. IN NO EVENT SHALL TI BE LIABLE FOR ANY ACTUAL, DIRECT, SPECIAL, COLLATERAL, INDIRECT, PUNITIVE, INCIDENTAL, CONSEQUENTIAL OR EXEMPLARY DAMAGES IN CONNECTION WITH OR ARISING OUT OF TI RESOURCES OR USE THEREOF, AND REGARDLESS OF WHETHER TI HAS BEEN ADVISED OF THE POSSIBILITY OF SUCH DAMAGES.

Unless TI has explicitly designated an individual product as meeting the requirements of a particular industry standard (e.g., ISO/TS 16949 and ISO 26262), TI is not responsible for any failure to meet such industry standard requirements.

Where TI specifically promotes products as facilitating functional safety or as compliant with industry functional safety standards, such products are intended to help enable customers to design and create their own applications that meet applicable functional safety standards and requirements. Using products in an application does not by itself establish any safety features in the application. Designers must ensure compliance with safety-related requirements and standards applicable to their applications. Designer may not use any TI products in life-critical medical equipment unless authorized officers of the parties have executed a special contract specifically governing such use. Life-critical medical equipment is medical equipment where failure of such equipment would cause serious bodily injury or death (e.g., life support, pacemakers, defibrillators, heart pumps, neurostimulators, and implantables). Such equipment includes, without limitation, all medical devices identified by the U.S. Food and Drug Administration as Class III devices and equivalent classifications outside the U.S.

TI may expressly designate certain products as completing a particular qualification (e.g., Q100, Military Grade, or Enhanced Product). Designers agree that it has the necessary expertise to select the product with the appropriate qualification designation for their applications and that proper product selection is at Designers' own risk. Designers are solely responsible for compliance with all legal and regulatory requirements in connection with such selection.

Designer will fully indemnify TI and its representatives against any damages, costs, losses, and/or liabilities arising out of Designer's non-compliance with the terms and provisions of this Notice.

Looking for pricing, stock, or lifecycle information?

Click below to explore more details on WIN SOURCE:

 [View LMV1091TM/NOPB on WIN SOURCE](#)

 [Texas Instruments](#) Information

Optimize Your Supply Chain with WIN SOURCE Solutions

-  Global Sourcing Solution
-  Obsolete Management
-  Cost Control Management
-  Shortage Management
-  Alternative Solution
-  Excess Inventory Management