

LMT89 2.4-V, 10- μ A, SC70 Temperature Sensor

1 Features

- Cost-Effective Alternative to Thermistors
- Rated for full -55°C to 130°C Range
- Available in an SC70 Package
- Predictable Curvature Error
- Suitable for Remote Applications

2 Applications

- Industrial
- HVAC
- Automotive
- Disk Drives
- Portable Medical Instruments
- Computers
- Battery Management
- Printers
- Power Supply Modules
- FAX Machines
- Mobile Phones
- Automotive

3 Description

The LMT89 device is a precision analog output CMOS integrated-circuit temperature sensor that operates over a -55°C to 130°C temperature range. The power supply operating range is 2.4 V to 5.5 V. The transfer function of LMT89 device is predominately linear, yet has a slight predictable parabolic curvature. The accuracy of the LMT89 device, when specified to a parabolic transfer function, is typically $\pm 1.5^{\circ}\text{C}$ at an ambient temperature of 30°C . The temperature error increases linearly and reaches a maximum of $\pm 2.5^{\circ}\text{C}$ at the temperature range extremes. The temperature range is affected by the power supply voltage. At a power supply voltage of 2.7 V to 5.5 V, the temperature range extremes are 130°C and -55°C . Decreasing the power supply voltage to 2.4 V changes the negative extreme to -30°C , while the positive remains at 130°C .

The quiescent current of the LMT89 device is less than $10\ \mu\text{A}$. Therefore, self-heating is less than 0.02°C in still air. Shutdown capability for the LMT89 device is intrinsic because its inherent low power consumption allows it to be powered directly from the output of many logic gates or does not necessitate shutdown at all.

The LMT89 device is a cost-competitive alternative to thermistors.

Device Information⁽¹⁾

PART NUMBER	PACKAGE	BODY SIZE (NOM)
LMT89	SOT (5)	2.00 mm x 1.25 mm

(1) For all available packages, see the orderable addendum at the end of the datasheet.

Simplified Schematic

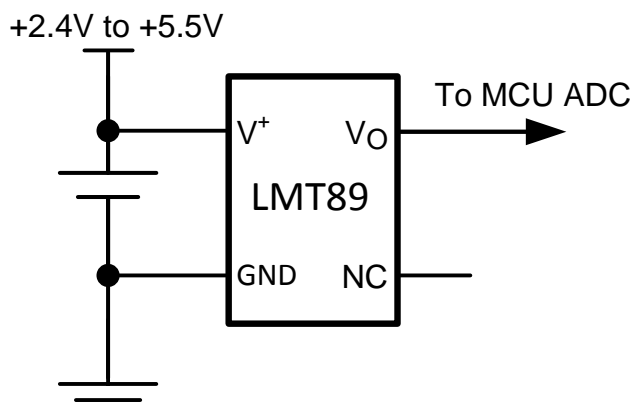

Output Voltage vs Temperature

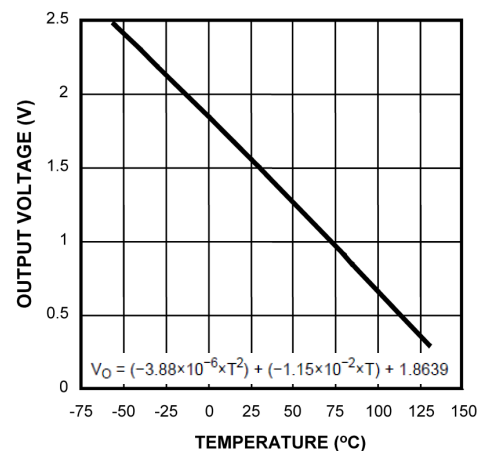

Table of Contents

1 Features	1	7.3 Feature Description	6
2 Applications	1	7.4 Device Functional Modes	7
3 Description	1	8 Application and Implementation	8
4 Revision History	2	8.1 Application Information	8
5 Pin Configuration and Functions	3	8.2 Typical Applications	9
6 Specifications	4	8.3 System Examples	11
6.1 Absolute Maximum Ratings	4	9 Power Supply Recommendations	12
6.2 ESD Ratings	4	10 Layout	12
6.3 Recommended Operating Conditions	4	10.1 Layout Guidelines	12
6.4 Thermal Information	4	10.2 Layout Example	13
6.5 Electrical Characteristics	5	11 Device and Documentation Support	14
6.6 Typical Characteristics	5	11.1 Trademarks	14
7 Detailed Description	6	11.2 Electrostatic Discharge Caution	14
7.1 Overview	6	11.3 Glossary	14
7.2 Functional Block Diagram	6	12 Mechanical, Packaging, and Orderable Information	14

4 Revision History

Changes from Original (March 2013) to Revision A

Page

- Added *Pin Configuration and Functions* section, *ESD Ratings* table, *Feature Description* section, *Device Functional Modes*, *Application and Implementation* section, *Power Supply Recommendations* section, *Layout* section, *Device and Documentation Support* section, and *Mechanical, Packaging, and Orderable Information* section **1**

5 Pin Configuration and Functions

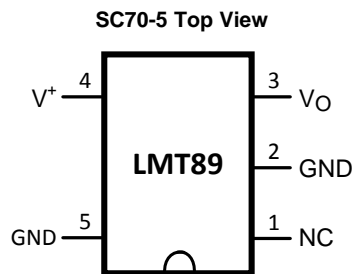

Pin Functions

PIN		I/O	DESCRIPTION
NO.	NAME		
1	NC	—	NC (pin 1) must be left floating or grounded. Other signal traces must not be connected to this pin.
2	GND	GND	Device substrate and die attach paddle, connect to power supply negative terminal. For optimum thermal conductivity to the PC board ground plane, pin 2 must be grounded. This pin may also be left floating.
3	V_O	Analog Output	Temperature sensor analog output
4	V^+	Power	Positive power supply pin
5	GND	GND	Device ground pin, connect to power supply negative terminal.

6 Specifications

6.1 Absolute Maximum Ratings

 over operating free-air temperature range (unless otherwise noted)⁽¹⁾⁽²⁾

	MIN	MAX	UNIT
Supply Voltage	-0.2	6.5	V
Output Voltage	(V ⁺ + 0.6 V)	-0.6	V
Output Current		10	mA
Input Current at any pin ⁽³⁾	5		mA
Maximum Junction Temperature (T _{JMAX})		150	°C
Storage temperature (T _{stg})	-65	150	°C

- (1) Stresses beyond those listed under *Absolute Maximum Ratings* may cause permanent damage to the device. These are stress ratings only, which do not imply functional operation of the device at these or any other conditions beyond those indicated under *Recommended Operating Conditions*. Exposure to absolute-maximum-rated conditions for extended periods may affect device reliability.
- (2) Soldering process must comply with the Reflow Temperature Profile specifications. Refer to <http://www.ti.com/packaging>. Reflow temperature profiles are different for lead-free and non-lead-free packages.
- (3) When the input voltage (V_I) at any pin exceeds power supplies (V_I < GND or V_I > V⁺), the current at that pin should be limited to 5 mA.

6.2 ESD Ratings

		VALUE	UNIT
V _(ESD) ⁽¹⁾ Electrostatic discharge	Human-body model (HBM), per ANSI/ESDA/JEDEC JS-001 ⁽²⁾	±2500	V
	Charged-device model (CDM), per JEDEC specification JESD22-C101 ⁽³⁾	±250	

- (1) Accuracy is defined as the error between the measured and calculated output voltage at the specified conditions of voltage, current, and temperature (expressed in °C).
- (2) JEDEC document JEP155 states that 500-V HBM allows safe manufacturing with a standard ESD control process.
- (3) JEDEC document JEP157 states that 250-V CDM allows safe manufacturing with a standard ESD control process.

6.3 Recommended Operating Conditions

over operating free-air temperature range (unless otherwise noted)

	MIN	MAX	UNIT
LMT89 with 2.4 V ≤ V ⁺ ≤ 2.7 V	-30	130	°C
LMT89 with 2.7 V ≤ V ⁺ ≤ 5.5 V	-55	130	°C
Supply Voltage Range (V ⁺)	2.4	5.5	V

6.4 Thermal Information

THERMAL METRIC ⁽¹⁾		LMT89	UNIT
		SOT	
		5 PINS	
R _{θJA}	Junction-to-ambient thermal resistance	282	°C/W
R _{θJC(top)}	Junction-to-case (top) thermal resistance	93	
R _{θJB}	Junction-to-board thermal resistance	62	
Ψ _{JT}	Junction-to-top characterization parameter	1.6	
Ψ _{JB}	Junction-to-board characterization parameter	62	
R _{θJC(bot)}	Junction-to-case (bottom) thermal resistance	—	

- (1) For more information about traditional and new thermal metrics, see the *IC Package Thermal Metrics* application report, [SPRA953](http://www.ti.com/lit/zip/SRA953). For measured thermal resistance using specific printed circuit board layouts for the LMT89, see [Layout](#).

6.5 Electrical Characteristics

Unless otherwise noted, these specifications apply for $V^+ = 2.7 V_{DC}$. All limits $T_A = T_J = T_{MIN}$ to T_{MAX} , unless otherwise noted.

PARAMETER	TEST CONDITIONS	MIN ⁽¹⁾	TYP ⁽²⁾	MAX ⁽¹⁾	UNIT
Temperature to Voltage Error $V_O = (-3.88 \times 10^{-6} \times T^2) + (-1.15 \times 10^{-2} \times T) + 1.8639 V^{(3)}$		-2.5	±1.5	2.5	°C
Output Voltage at 0°C			1.8639		V
Variance from Curve			±1.0		°C
Non-Linearity ⁽⁴⁾	$-20^\circ\text{C} \leq T_A \leq 80^\circ\text{C}$		±0.4%		
Sensor Gain (Temperature Sensitivity or Average Slope) to equation: $V_O = -11.77 \text{ mV}/^\circ\text{C} \times T + 1.860 \text{ V}$	$-30^\circ\text{C} \leq T_A \leq 100^\circ\text{C}$	-12.2	-11.77	-11.4	mV/°C
Output Impedance	Sourcing I_L 0 μA to 16 μA ⁽⁵⁾⁽⁶⁾			160	Ω
Load Regulation ⁽⁷⁾	Sourcing I_L 0 μA to 16 μA ⁽⁵⁾⁽⁶⁾			-2.5	mV
Line Regulation ⁽⁸⁾	$2.4 \text{ V} \leq V^+ \leq 5.0 \text{ V}$			3.3	mV/V
	$5.0 \text{ V} \leq V^+ \leq 5.5 \text{ V}$			11	mV
Quiescent Current	$2.4 \text{ V} \leq V^+ \leq 5.0 \text{ V}; T_A = 25^\circ\text{C}$		4.5	7	μA
	$5.0 \text{ V} \leq V^+ \leq 5.5 \text{ V}; T_A = 25^\circ\text{C}$		4.5	9	μA
	$2.4 \text{ V} \leq V^+ \leq 5.0 \text{ V}$		4.5	10	μA
Change of Quiescent Current	$2.4 \text{ V} \leq V^+ \leq 5.5 \text{ V}$		0.7		μA
Temperature Coefficient of Quiescent Current			-11		nA/°C
Shutdown Current	$V^+ \leq 0.8 \text{ V}$		0.02		μA

- (1) Limits are specified to TI's AOQL (Average Outgoing Quality Level).
- (2) Typical values are at $T_J = T_A = 25^\circ\text{C}$ and represent most likely parametric norm.
- (3) Accuracy is defined as the error between the measured and calculated output voltage at the specified conditions of voltage, current, and temperature (expressed in °C).
- (4) Non-Linearity is defined as the deviation of the calculated output-voltage-versus-temperature curve from the best-fit straight line, over the temperature range specified.
- (5) The LMT89 can at most sink 1 μA and source 16 μA .
- (6) Load regulation or output impedance specifications apply over the supply voltage range of 2.4 V to 5.5 V.
- (7) Regulation is measured at constant junction temperature, using pulse testing with a low duty cycle. Changes in output due to heating effects can be computed by multiplying the internal dissipation by the thermal resistance.
- (8) Line regulation is calculated by subtracting the output voltage at the highest supply input voltage from the output voltage at the lowest supply input voltage.

6.6 Typical Characteristics

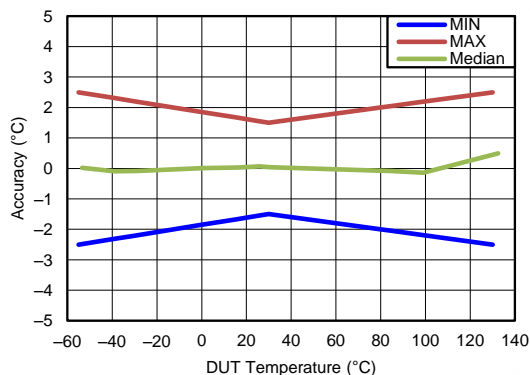

Figure 1. Temperature Sensor Accuracy

7 Detailed Description

7.1 Overview

The LMT89 device is a precision analog output CMOS integrated-circuit temperature sensor that operates over a temperature range of -55°C to 130°C . The power supply operating range is 2.4 V to 5.5 V. The transfer function of LMT89 is predominately linear, yet has a slight predictable parabolic curvature. The accuracy of the LMT89 device, when specified to a parabolic transfer function, is typically $\pm 1.5^{\circ}\text{C}$ at an ambient temperature of 30°C . The temperature error increases linearly and reaches a maximum of $\pm 5^{\circ}\text{C}$ at the temperature range extremes. The temperature range is affected by the power supply voltage. At a power supply voltage of 2.7 V to 5.5 V, the temperature range extremes are 130°C and -55°C . Decreasing the power supply voltage to 2.4 V changes the negative extreme to -30°C , while the positive remains at 130°C .

The LMT89 quiescent current is less than $10\ \mu\text{A}$. Therefore, self-heating is less than 0.02°C in still air. Shutdown capability for the LMT89 is intrinsic because its inherent low power consumption allows it to be powered directly from the output of many logic gates or does not necessitate shutdown at all.

The temperature sensing element is comprised of a simple base emitter junction that is forward biased by a current source. The temperature sensing element is then buffered by an amplifier and provided to the OUT pin. The amplifier has a simple class A output stage thus providing a low impedance output that can source $16\ \mu\text{A}$ and sink $1\ \mu\text{A}$.

7.2 Functional Block Diagram

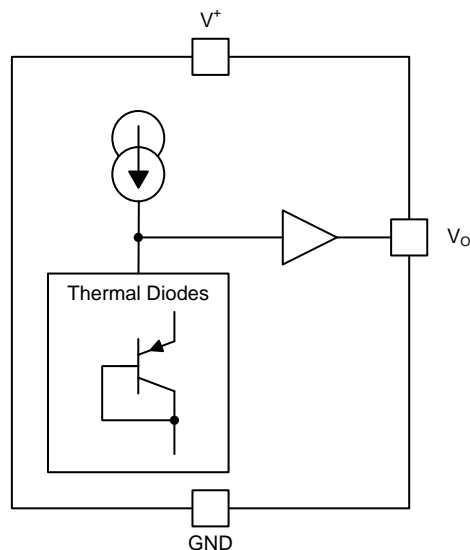

7.3 Feature Description

7.3.1 LMT89 Transfer Function

The transfer function of the LMT89 device can be described in different ways with varying levels of precision. A simple linear transfer function with good accuracy near 25°C is shown in [Equation 1](#).

$$V_o = -11.69\ \text{mV}/^{\circ}\text{C} \times T + 1.8663\ \text{V} \quad (1)$$

Over the full operating temperature range of -55°C to 130°C , best accuracy can be obtained by using the parabolic transfer function.

$$V_o = (-3.88 \times 10^{-6} \times T^2) + (-1.15 \times 10^{-2} \times T) + 1.8639 \quad (2)$$

Using [Equation 2](#) the following temperature to voltage output characteristic table can be generated.

Feature Description (continued)
Table 1. Temperature to Voltage Output Characteristic Table

TEMP (°C)	VOUT (V)	TEMP (°C)	VOUT (V)	TEMP (°C)	VOUT (V)	TEMP (°C)	VOUT (V)	TEMP (°C)	VOUT (V)	TEMP (°C)	VOUT (V)	TEMP (°C)	VOUT (V)
-55	2.4847	-28	2.1829	-1	1.8754	26	1.5623	53	1.2435	80	0.9191	107	0.5890
-54	2.4736	-27	2.1716	0	1.8639	27	1.5506	54	1.2316	81	0.9069	108	0.5766
-53	2.4625	-26	2.1603	1	1.8524	28	1.5389	55	1.2197	82	0.8948	109	0.5643
-52	2.4514	-25	2.1490	2	1.8409	29	1.5271	56	1.2077	83	0.8827	110	0.5520
-51	2.4403	-24	2.1377	3	1.8294	30	1.5154	57	1.1958	84	0.8705	111	0.5396
-50	2.4292	-23	2.1263	4	1.8178	31	1.5037	58	1.1838	85	0.8584	112	0.5272
-49	2.4181	-22	2.1150	5	1.8063	32	1.4919	59	1.1719	86	0.8462	113	0.5149
-48	2.4070	-21	2.1037	6	1.7948	33	1.4802	60	1.1599	87	0.8340	114	0.5025
-47	2.3958	-20	2.0923	7	1.7832	34	1.4684	61	1.1480	88	0.8219	115	0.4901
-46	2.3847	-19	2.0810	8	1.7717	35	1.4566	62	1.1360	89	0.8097	116	0.4777
-45	2.3735	-18	2.0696	9	1.7601	36	1.4449	63	1.1240	90	0.7975	117	0.4653
-44	2.3624	-17	2.0583	10	1.7485	37	1.4331	64	1.1120	91	0.7853	118	0.4529
-43	2.3512	-16	2.0469	11	1.7369	38	1.4213	65	1.1000	92	0.7731	119	0.4405
-42	2.3401	-15	2.0355	12	1.7253	39	1.4095	66	1.0880	93	0.7608	120	0.4280
-41	2.3289	-14	2.0241	13	1.7137	40	1.3977	67	1.0760	94	0.7486	121	0.4156
-40	2.3177	-13	2.0127	14	1.7021	41	1.3859	68	1.0640	95	0.7364	122	0.4032
-39	2.3065	-12	2.0013	15	1.6905	42	1.3741	69	1.0519	96	0.7241	123	0.3907
-38	2.2953	-11	1.9899	16	1.6789	43	1.3622	70	1.0399	97	0.7119	124	0.3782
-37	2.2841	-10	1.9785	17	1.6673	44	1.3504	71	1.0278	98	0.6996	125	0.3658
-36	2.2729	-9	1.9671	18	1.6556	45	1.3385	72	1.0158	99	0.6874	126	0.3533
-35	2.2616	-8	1.9557	19	1.6440	46	1.3267	73	1.0037	100	0.6751	127	0.3408
-34	2.2504	-7	1.9442	20	1.6323	47	1.3148	74	0.9917	101	0.6628	128	0.3283
-33	2.2392	-6	1.9328	21	1.6207	48	1.3030	75	0.9796	102	0.6505	129	0.3158
-32	2.2279	-5	1.9213	22	1.6090	49	1.2911	76	0.9675	103	0.6382	130	0.3033
-31	2.2167	-4	1.9098	23	1.5973	50	1.2792	77	0.9554	104	0.6259	—	—
-30	2.2054	-3	1.8984	24	1.5857	51	1.2673	78	0.9433	105	0.6136	—	—
-29	2.1941	-2	1.8869	25	1.5740	52	1.2554	79	0.9312	106	0.6013	—	—

Solving Equation 2 for T:

$$T = -1481.96 + \sqrt{2.1962 \times 10^6 + \frac{(1.8639 - V_O)}{3.88 \times 10^{-6}}} \quad (3)$$

For other methods of calculating T, see [Detailed Design Procedure](#).

7.4 Device Functional Modes

The only functional mode of the LMT89 device is that it has an analog output inversely proportional to temperature.

8 Application and Implementation

NOTE

Information in the following applications sections is not part of the TI component specification, and TI does not warrant its accuracy or completeness. TI's customers are responsible for determining suitability of components for their purposes. Customers should validate and test their design implementation to confirm system functionality.

8.1 Application Information

The LMT89 has a very low supply current and a wide supply range therefore it can easily be driven by a battery as shown in [Figure 4](#).

8.1.1 Capacitive Loads

The LMT89 device handles capacitive loading well. Without any precautions, the LMT89 device can drive any capacitive load less than 300 pF as shown in [Figure 2](#). The specified temperature range the LMT89 device has a maximum output impedance of 160 Ω. In an extremely noisy environment it may be necessary to add some filtering to minimize noise pickup. TI recommends that 0.1 μF be added from V⁺ to GND to bypass the power supply voltage, as shown in [Figure 2](#). In a noisy environment it may even be necessary to add a capacitor from the output to ground with a series resistor as shown in [Figure 2](#). A 1-μF output capacitor with the 160-Ω maximum output impedance and a 200-Ω series resistor will form a 442-Hz lowpass filter. Because the thermal time constant of the LMT89 device is much slower, the overall response time of the LMT89 device will not be significantly affected.

In situations where a transient load current is placed on the circuit output, the series resistance value may be increased to compensate for any ringing that may be observed.

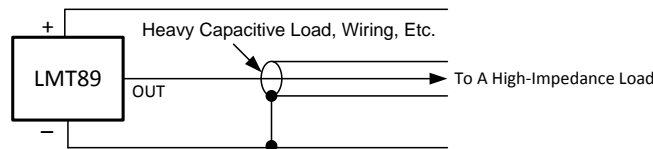

Figure 2. LMT89 No Decoupling Required for Capacitive Loads Less Than 300 pF

Table 2. Design Parameters

Minimum R (Ω)	C (μF)
200	1
470	0.1
680	0.01
1 k	0.001

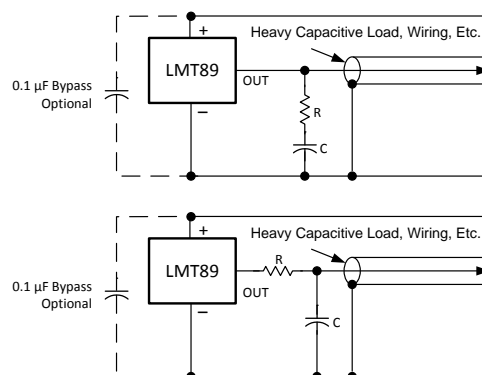

Figure 3. LMT89 With Filter for Noisy Environment and Capacitive Loading Greater Than 300 pF

NOTE

Either placement of resistor, as shown in [Figure 2](#) and [Figure 3](#), is just as effective.

8.2 Typical Applications

8.2.1 Full-Range Centigrade Temperature Sensor

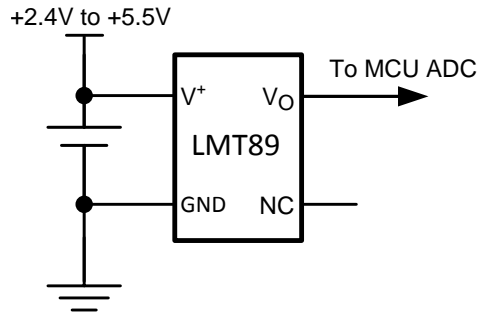

Figure 4. Full-Range Celsius (Centigrade) Temperature Sensor (–55°C to 130°C) Operating from a Single Li-Ion Battery Cell

8.2.1.1 Design Requirements

Design requirements related to layout are also important because the LMT89 device is a simple temperature sensor that provides an analog output, refer to [Layout](#) for a detailed description.

8.2.1.2 Detailed Design Procedure

The LMT89 device output is shown in [Equation 4](#).

$$V_O = (-3.88 \times 10^{-6} \times T^2) + (-1.15 \times 10^{-2} \times T) + 1.8639 \quad (4)$$

Solve for T as shown in [Equation 5](#):

$$T = -1481.96 + \sqrt{2.1962 \times 10^6 + \frac{(1.8639 - V_O)}{3.88 \times 10^{-6}}}$$

where

- T is temperature, and V_O is the measured output voltage of the LMT89 device. [Equation 5](#) is the most accurate equation that can be used to calculate the temperature of the LMT89 device. (5)

An alternative to the quadratic equation a second order transfer function can be determined using the least squares method shown in [Equation 6](#).

$$T = (-2.3654 \times V_O^2) + (-78.154 \times V_O) + 153.857$$

where

- T is temperature expressed in °C and V_O is the output voltage expressed in volts. (6)

A linear transfer function can be used over a limited temperature range by calculating a slope and offset that give best results over that range. A linear transfer function can be calculated from the parabolic transfer function of the LMT89 device. The slope of the linear transfer function can be calculated using [Equation 7](#).

$$m = -7.76 \times 10^{-6} \times T - 0.0115,$$

where

- T is the middle of the temperature range of interest and m is in V/°C. For example for the temperature range of $T_{MIN} = -30$ to $T_{MAX} = 100$ °C (7)

$$T = 35^\circ\text{C} \quad (8)$$

and

$$m = -11.77 \text{ mV}/^\circ\text{C} \quad (9)$$

Typical Applications (continued)

The offset of the linear transfer function can be calculated using Equation 10.

$$b = (V_{OP}(T_{MAX}) + V_{OP}(T) - m \times (T_{MAX}+T)) / 2$$

where

- $V_{OP}(T_{MAX})$ is the calculated output voltage at T_{MAX} using the parabolic transfer function for V_O .
- $V_{OP}(T)$ is the calculated output voltage at T using the parabolic transfer function for V_O . (10)

The best fit linear transfer function for many popular temperature ranges was calculated in Table 3. As shown in Table 3, the error introduced by the linear transfer function increases with wider temperature ranges.

Table 3. First Order Equations Optimized for Different Temperature Ranges

TEMPERATURE RANGE		LINEAR EQUATION	MAXIMUM DEVIATION OF LINEAR EQUATION FROM PARABOLIC EQUATION (°C)
T _{min} (°C)	T _{max} (°C)		
-55	130	$V_O = -11.79 \text{ mV/}^\circ\text{C} \times T + 1.8528 \text{ V}$	±1.41
-40	110	$V_O = -11.77 \text{ mV/}^\circ\text{C} \times T + 1.8577 \text{ V}$	±0.93
-30	100	$V_O = -11.77 \text{ mV/}^\circ\text{C} \times T + 1.8605 \text{ V}$	±0.70
-40	85	$V_O = -11.67 \text{ mV/}^\circ\text{C} \times T + 1.8583 \text{ V}$	±0.65
-10	65	$V_O = -11.71 \text{ mV/}^\circ\text{C} \times T + 1.8641 \text{ V}$	±0.23
35	45	$V_O = -11.81 \text{ mV/}^\circ\text{C} \times T + 1.8701 \text{ V}$	±0.004
20	30	$V_O = -11.69 \text{ mV/}^\circ\text{C} \times T + 1.8663 \text{ V}$	±0.004

8.2.1.3 Application Curve

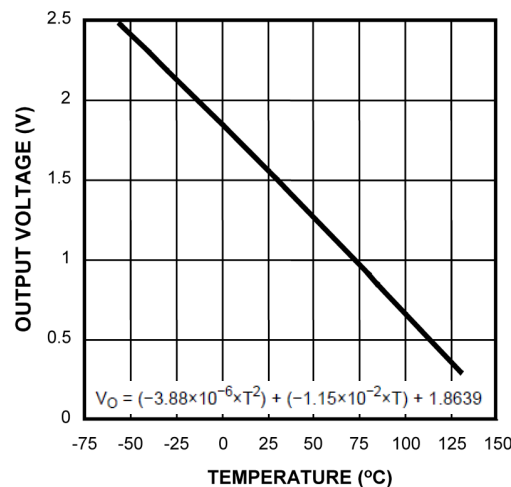

Figure 5. Output Voltage vs Temperature

8.2.2 Centigrade Thermostat

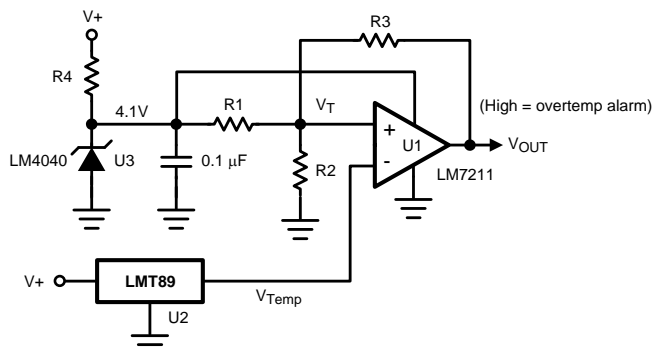

Figure 6. Centigrade Thermostat

8.2.2.1 Design Requirements

A simple thermostat can be created by using a reference (LM4040) and a comparator (LM7211) as shown in Figure 6.

8.2.2.2 Detailed Design Procedure

The threshold values can be calculated using Equation 11 and Equation 12.

$$V_{T1} = \frac{(4.1)R2}{R2 + R1 \parallel R3} \quad (11)$$

$$V_{T2} = \frac{(4.1)R2 \parallel R3}{R1 + R2 \parallel R3} \quad (12)$$

8.2.2.3 Application Curve

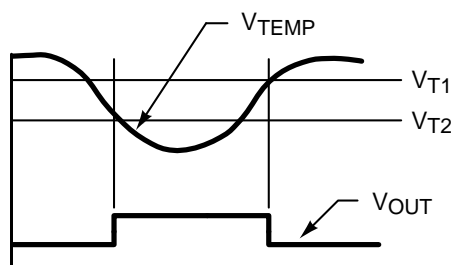

Figure 7. Thermostat Output Waveform

8.3 System Examples

8.3.1 Conserving Power Dissipation With Shutdown

The LMT89 device draws very little power therefore it can simply be shutdown by driving its supply pin with the output of an logic gate as shown in Figure 8.

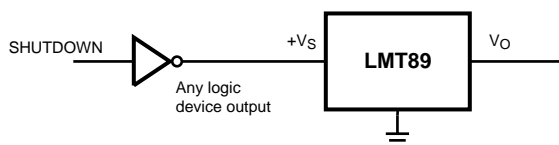

Figure 8. Conserving Power Dissipation With Shutdown

System Examples (continued)

8.3.2 Analog-to-Digital Converter Input Stage

Most CMOS ADCs found in ASICs have a sampled data comparator input structure that is notorious for causing problems for analog output devices, such as the LMT89 and many op amps. The cause of this difficulty is the requirement of instantaneous charge of the input sampling capacitor in the ADC. This requirement is easily accommodated by the addition of a capacitor. Because not all ADCs have identical input stages, the charge requirements will vary necessitating a different value of compensating capacitor. This ADC is shown as an example only. If a digital output temperature is required, refer to devices such as the LM74 device.

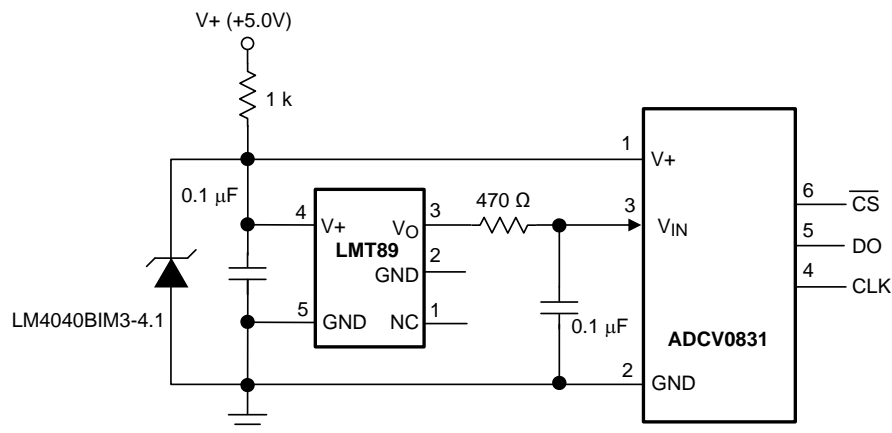

Figure 9. Suggested Connection to a Sampling Analog-to-Digital Converter Input Stage

9 Power Supply Recommendations

The LMT89 device has a very wide 2.4-V to 5.5-V power supply voltage range making it ideal for many applications. In noisy environments, TI recommends adding at minimum 0.1 μ F from V⁺ to GND to bypass the power supply voltage. Larger capacitances maybe required and are dependent on the power supply noise.

10 Layout

10.1 Layout Guidelines

The LMT89 device can be applied easily in the same way as other integrated-circuit temperature sensors. It can be glued or cemented to a surface. The temperature that the LMT89 device is sensing will be within about 0.02°C of the surface temperature to which the leads of the LMT89 device are attached.

This presumes that the ambient air temperature is almost the same as the surface temperature; if the air temperature were much higher or lower than the surface temperature, the actual temperature measured would be at an intermediate temperature between the surface temperature and the air temperature.

To ensure good thermal conductivity the backside of the LMT89 die is directly attached to the pin 2 GND pin. The temperatures of the lands and traces to the other leads of the LMT89 will also affect the temperature that is being sensed.

Alternatively, the LMT89 device can be mounted inside a sealed-end metal tube, and can then be dipped into a bath or screwed into a threaded hole in a tank. As with any IC, the LMT89 device and accompanying wiring and circuits must be kept insulated and dry, to avoid leakage and corrosion. This is especially true if the circuit may operate at cold temperatures where condensation can occur. Printed-circuit coatings and varnishes such as Humiseal and epoxy paints or dips are often used to ensure that moisture cannot corrode the LMT89 or its connections.

Layout Guidelines (continued)

The thermal resistance junction to ambient ($R_{\theta JA}$) is the parameter used to calculate the rise of a device junction temperature due to its power dissipation. Equation 13 is used to calculate the rise in the die temperature.

$$T_J = T_A + R_{\theta JA} [(V^+ I_Q) + (V^+ - V_O) I_L]$$

where

- I_Q is the quiescent current and I_L is the load current on the output. Because the junction temperature of the LMT89 is the actual temperature being measured, take care to minimize the load current that the LMT89 device is required to drive. (13)

Table 4 summarizes the rise in die temperature of the LMT89 device (without any loading), and the thermal resistance for different conditions.

Table 4. Temperature Rise of LMT89 Due to Self-Heating and Thermal Resistance ($R_{\theta JA}$)⁽¹⁾

	SC70-5		SC70-5	
	NO HEAT SINK		SMALL HEAT SINK	
	$R_{\theta JA}$ (°C/W)	$T_J - T_A$ (°C)	$R_{\theta JA}$ (°C/W)	$T_J - T_A$ (°C)
Still air	412	0.2	350	0.19
Moving air	312	0.17	266	0.15

(1) See [Layout Examples](#) for PCB layout samples.

10.2 Layout Example

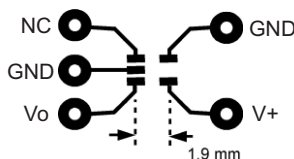

Figure 10. Layout Used for No Heat Sink Measurements

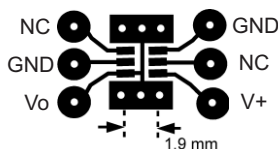

Figure 11. Layout Used for Measurements With Small Heat Sink

11 Device and Documentation Support

11.1 Trademarks

All trademarks are the property of their respective owners.

11.2 Electrostatic Discharge Caution



These devices have limited built-in ESD protection. The leads should be shorted together or the device placed in conductive foam during storage or handling to prevent electrostatic damage to the MOS gates.

11.3 Glossary

[SLYZ022](#) — *TI Glossary*.

This glossary lists and explains terms, acronyms, and definitions.

12 Mechanical, Packaging, and Orderable Information

The following pages include mechanical, packaging, and orderable information. This information is the most current data available for the designated devices. This data is subject to change without notice and revision of this document. For browser-based versions of this data sheet, refer to the left-hand navigation.

PACKAGING INFORMATION

Orderable Device	Status (1)	Package Type	Package Drawing	Pins	Package Qty	Eco Plan (2)	Lead/Ball Finish (6)	MSL Peak Temp (3)	Op Temp (°C)	Device Marking (4/5)	Samples
LMT89DCKR	ACTIVE	SC70	DCK	5	3000	Green (RoHS & no Sb/Br)	CU SN	Level-1-260C-UNLIM	-55 to 130	T3B	Samples
LMT89DCKT	ACTIVE	SC70	DCK	5	250	Green (RoHS & no Sb/Br)	CU SN	Level-1-260C-UNLIM	-55 to 130	T3B	Samples

(1) The marketing status values are defined as follows:

ACTIVE: Product device recommended for new designs.

LIFEBUY: TI has announced that the device will be discontinued, and a lifetime-buy period is in effect.

NRND: Not recommended for new designs. Device is in production to support existing customers, but TI does not recommend using this part in a new design.

PREVIEW: Device has been announced but is not in production. Samples may or may not be available.

OBsolete: TI has discontinued the production of the device.

(2) Eco Plan - The planned eco-friendly classification: Pb-Free (RoHS), Pb-Free (RoHS Exempt), or Green (RoHS & no Sb/Br) - please check <http://www.ti.com/productcontent> for the latest availability information and additional product content details.

TBD: The Pb-Free/Green conversion plan has not been defined.

Pb-Free (RoHS): TI's terms "Lead-Free" or "Pb-Free" mean semiconductor products that are compatible with the current RoHS requirements for all 6 substances, including the requirement that lead not exceed 0.1% by weight in homogeneous materials. Where designed to be soldered at high temperatures, TI Pb-Free products are suitable for use in specified lead-free processes.

Pb-Free (RoHS Exempt): This component has a RoHS exemption for either 1) lead-based flip-chip solder bumps used between the die and package, or 2) lead-based die adhesive used between the die and leadframe. The component is otherwise considered Pb-Free (RoHS compatible) as defined above.

Green (RoHS & no Sb/Br): TI defines "Green" to mean Pb-Free (RoHS compatible), and free of Bromine (Br) and Antimony (Sb) based flame retardants (Br or Sb do not exceed 0.1% by weight in homogeneous material)

(3) MSL, Peak Temp. - The Moisture Sensitivity Level rating according to the JEDEC industry standard classifications, and peak solder temperature.

(4) There may be additional marking, which relates to the logo, the lot trace code information, or the environmental category on the device.

(5) Multiple Device Markings will be inside parentheses. Only one Device Marking contained in parentheses and separated by a "~" will appear on a device. If a line is indented then it is a continuation of the previous line and the two combined represent the entire Device Marking for that device.

(6) Lead/Ball Finish - Orderable Devices may have multiple material finish options. Finish options are separated by a vertical ruled line. Lead/Ball Finish values may wrap to two lines if the finish value exceeds the maximum column width.

Important Information and Disclaimer: The information provided on this page represents TI's knowledge and belief as of the date that it is provided. TI bases its knowledge and belief on information provided by third parties, and makes no representation or warranty as to the accuracy of such information. Efforts are underway to better integrate information from third parties. TI has taken and continues to take reasonable steps to provide representative and accurate information but may not have conducted destructive testing or chemical analysis on incoming materials and chemicals. TI and TI suppliers consider certain information to be proprietary, and thus CAS numbers and other limited information may not be available for release.

In no event shall TI's liability arising out of such information exceed the total purchase price of the TI part(s) at issue in this document sold by TI to Customer on an annual basis.

TAPE AND REEL INFORMATION



QUADRANT ASSIGNMENTS FOR PIN 1 ORIENTATION IN TAPE



*All dimensions are nominal

Device	Package Type	Package Drawing	Pins	SPQ	Reel Diameter (mm)	Reel Width W1 (mm)	A0 (mm)	B0 (mm)	K0 (mm)	P1 (mm)	W (mm)	Pin1 Quadrant
LMT89DCKR	SC70	DCK	5	3000	178.0	8.4	2.25	2.45	1.2	4.0	8.0	Q3
LMT89DCKT	SC70	DCK	5	250	178.0	8.4	2.25	2.45	1.2	4.0	8.0	Q3

TAPE AND REEL BOX DIMENSIONS

*All dimensions are nominal

Device	Package Type	Package Drawing	Pins	SPQ	Length (mm)	Width (mm)	Height (mm)
LMT89DCKR	SC70	DCK	5	3000	210.0	185.0	35.0
LMT89DCKT	SC70	DCK	5	250	210.0	185.0	35.0

DCK (R-PDSO-G5)

PLASTIC SMALL-OUTLINE PACKAGE



- NOTES:
- A. All linear dimensions are in millimeters.
 - B. This drawing is subject to change without notice.
 - C. Body dimensions do not include mold flash or protrusion. Mold flash and protrusion shall not exceed 0.15 per side.
 - D. Falls within JEDEC MO-203 variation AA.

DCK (R-PDSO-G5)

PLASTIC SMALL OUTLINE



- NOTES:
- All linear dimensions are in millimeters.
 - This drawing is subject to change without notice.
 - Customers should place a note on the circuit board fabrication drawing not to alter the center solder mask defined pad.
 - Publication IPC-7351 is recommended for alternate designs.
 - Laser cutting apertures with trapezoidal walls and also rounding corners will offer better paste release. Customers should contact their board assembly site for stencil design recommendations. Example stencil design based on a 50% volumetric metal load solder paste. Refer to IPC-7525 for other stencil recommendations.

IMPORTANT NOTICE

Texas Instruments Incorporated and its subsidiaries (TI) reserve the right to make corrections, enhancements, improvements and other changes to its semiconductor products and services per JESD46, latest issue, and to discontinue any product or service per JESD48, latest issue. Buyers should obtain the latest relevant information before placing orders and should verify that such information is current and complete. All semiconductor products (also referred to herein as "components") are sold subject to TI's terms and conditions of sale supplied at the time of order acknowledgment.

TI warrants performance of its components to the specifications applicable at the time of sale, in accordance with the warranty in TI's terms and conditions of sale of semiconductor products. Testing and other quality control techniques are used to the extent TI deems necessary to support this warranty. Except where mandated by applicable law, testing of all parameters of each component is not necessarily performed.

TI assumes no liability for applications assistance or the design of Buyers' products. Buyers are responsible for their products and applications using TI components. To minimize the risks associated with Buyers' products and applications, Buyers should provide adequate design and operating safeguards.

TI does not warrant or represent that any license, either express or implied, is granted under any patent right, copyright, mask work right, or other intellectual property right relating to any combination, machine, or process in which TI components or services are used. Information published by TI regarding third-party products or services does not constitute a license to use such products or services or a warranty or endorsement thereof. Use of such information may require a license from a third party under the patents or other intellectual property of the third party, or a license from TI under the patents or other intellectual property of TI.

Reproduction of significant portions of TI information in TI data books or data sheets is permissible only if reproduction is without alteration and is accompanied by all associated warranties, conditions, limitations, and notices. TI is not responsible or liable for such altered documentation. Information of third parties may be subject to additional restrictions.

Resale of TI components or services with statements different from or beyond the parameters stated by TI for that component or service voids all express and any implied warranties for the associated TI component or service and is an unfair and deceptive business practice. TI is not responsible or liable for any such statements.

Buyer acknowledges and agrees that it is solely responsible for compliance with all legal, regulatory and safety-related requirements concerning its products, and any use of TI components in its applications, notwithstanding any applications-related information or support that may be provided by TI. Buyer represents and agrees that it has all the necessary expertise to create and implement safeguards which anticipate dangerous consequences of failures, monitor failures and their consequences, lessen the likelihood of failures that might cause harm and take appropriate remedial actions. Buyer will fully indemnify TI and its representatives against any damages arising out of the use of any TI components in safety-critical applications.

In some cases, TI components may be promoted specifically to facilitate safety-related applications. With such components, TI's goal is to help enable customers to design and create their own end-product solutions that meet applicable functional safety standards and requirements. Nonetheless, such components are subject to these terms.

No TI components are authorized for use in FDA Class III (or similar life-critical medical equipment) unless authorized officers of the parties have executed a special agreement specifically governing such use.

Only those TI components which TI has specifically designated as military grade or "enhanced plastic" are designed and intended for use in military/aerospace applications or environments. Buyer acknowledges and agrees that any military or aerospace use of TI components which have **not** been so designated is solely at the Buyer's risk, and that Buyer is solely responsible for compliance with all legal and regulatory requirements in connection with such use.

TI has specifically designated certain components as meeting ISO/TS16949 requirements, mainly for automotive use. In any case of use of non-designated products, TI will not be responsible for any failure to meet ISO/TS16949.

Products

Audio	www.ti.com/audio
Amplifiers	amplifier.ti.com
Data Converters	dataconverter.ti.com
DLP® Products	www.dlp.com
DSP	dsp.ti.com
Clocks and Timers	www.ti.com/clocks
Interface	interface.ti.com
Logic	logic.ti.com
Power Mgmt	power.ti.com
Microcontrollers	microcontroller.ti.com
RFID	www.ti-rfid.com
OMAP Applications Processors	www.ti.com/omap
Wireless Connectivity	www.ti.com/wirelessconnectivity

Applications

Automotive and Transportation	www.ti.com/automotive
Communications and Telecom	www.ti.com/communications
Computers and Peripherals	www.ti.com/computers
Consumer Electronics	www.ti.com/consumer-apps
Energy and Lighting	www.ti.com/energy
Industrial	www.ti.com/industrial
Medical	www.ti.com/medical
Security	www.ti.com/security
Space, Avionics and Defense	www.ti.com/space-avionics-defense
Video and Imaging	www.ti.com/video

TI E2E Community

e2e.ti.com

Looking for pricing, stock, or lifecycle information?

Click below to explore more details on WIN SOURCE:

-  [View LMT89DCKT on WIN SOURCE](#)
-  [Texas Instruments](#) Information

Optimize Your Supply Chain with WIN SOURCE Solutions

-  Global Sourcing Solution
-  Obsolete Management
-  Cost Control Management
-  Shortage Management
-  Alternative Solution
-  Excess Inventory Management