



**THE DATASHEET OF
LMK03001CISQ/NOPB**



LMK03000 Family Precision Clock Conditioner with Integrated VCO

 Check for Samples: [LMK03000](#), [LMK03000C](#), [LMK03000D](#), [LMK03001](#), [LMK03001C](#), [LMK03001D](#), [LMK03033](#), [LMK03033C](#)

1 FEATURES

- Integrated VCO with Very Low Phase Noise Floor
- Integrated Integer-N PLL with Outstanding Normalized Phase Noise Contribution of -224 dBc/Hz
- VCO Divider Values of 2 to 8 (All Divides)
- Channel Divider Values of 1, 2 to 510 (even divides)
- LVDS and LVPECL Clock Outputs
- Partially Integrated Loop Filter
- Dedicated Divider and Delay Blocks on Each Clock Output
- Pin Compatible Family of Clocking Devices
- 3.15 to 3.45 V Operation
- Package: 48 Pin WQFN (7.0 x 7.0 x 0.8 mm)
- 200 fs RMS Clock Generator Performance (10 Hz to 20 MHz) with a Clean Input Clock

1.1 TARGET APPLICATIONS

- Data Converter Clocking
- Networking, SONET/SDH, DSLAM
- Wireless Infrastructure
- Medical
- Test and Measurement
- Military / Aerospace

Device	Outputs	VCO	
		Tuning Range (MHz)	RMS Jitter (fs)
LMK03000C	3 LVDS 5 LVPECL	1185 - 1296	400
LMK03000			800
LMK03000D			1200
LMK03001C		1470 - 1570	400
LMK03001			800
LMK03001D			1200
LMK03033C	4 LVDS	1843 - 2160	500
LMK03033	4 LVPECL		800

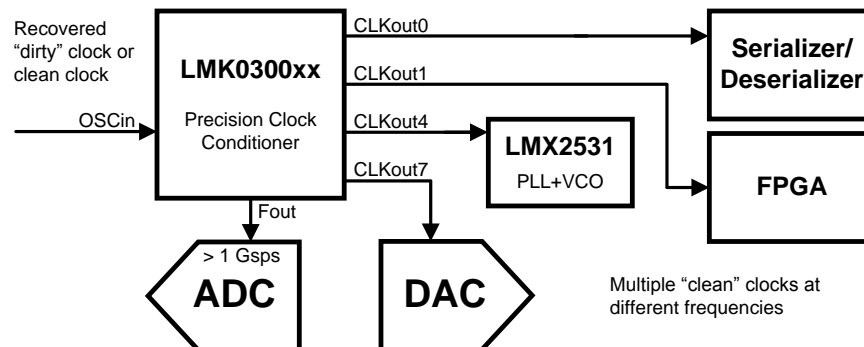

Please be aware that an important notice concerning availability, standard warranty, and use in critical applications of Texas Instruments semiconductor products and disclaimers thereto appears at the end of this data sheet.

All trademarks are the property of their respective owners.

1.2 DESCRIPTION

The LMK03000 family of precision clock conditioners combine the functions of jitter cleaning/reconditioning, multiplication, and distribution of a reference clock. The devices integrate a Voltage Controlled Oscillator (VCO), a high performance Integer-N Phase Locked Loop (PLL), a partially integrated loop filter, and up to eight outputs in various LVDS and LVPECL combinations.

The VCO output is optionally accessible on the Fout port. Internally, the VCO output goes through a VCO Divider to feed the various clock distribution blocks.

Each clock distribution block includes a programmable divider, a phase synchronization circuit, a programmable delay, a clock output mux, and an LVDS or LVPECL output buffer. This allows multiple integer-related and phase-adjusted copies of the reference to be distributed to eight system components.

The clock conditioners come in a 48-pin WQFN package and are footprint compatible with other clocking devices in the same family.

1	FEATURES	1	6.10	POWER ON RESET	17
1.1	TARGET APPLICATIONS	1	6.11	DIGITAL LOCK DETECT	18
1.2	DESCRIPTION	2	7	General Programming Information	19
2	Device Information	3	7.1	RECOMMENDED PROGRAMMING SEQUENCE	19
2.1	Functional Block Diagram	3	7.2	REGISTER R0 to R7	22
2.2	Connection Diagram	4	7.3	REGISTER R8	24
3	Electrical Specifications	6	7.4	REGISTER R9	24
3.1	Absolute Maximum Ratings	6	7.5	REGISTER R11	24
3.2	Recommended Operating Conditions	6	7.6	REGISTER R13	24
3.3	Package Thermal Resistance	6	7.7	REGISTER R14	25
3.4	Electrical Characteristics	7	7.8	REGISTER R15	27
3.5	Serial Data Timing Diagram	11	8	Application Information	28
4	Measurement Definitions	12	8.1	SYSTEM LEVEL DIAGRAM	28
4.1	Charge Pump Current Specification Definitions	12	8.2	BIAS PIN	28
5	Typical Performance Characteristics	13	8.3	LDO BYPASS	28
6	Functional Description	15	8.4	LOOP FILTER	29
6.1	BIAS PIN	15	8.5	CURRENT CONSUMPTION / POWER DISSIPATION CALCULATIONS	30
6.2	LDO BYPASS	15	8.6	THERMAL MANAGEMENT	31
6.3	OSCILLATOR INPUT PORT (OSCin, OSCin*)	15	8.7	TERMINATION AND USE OF CLOCK OUTPUTS (DRIVERS)	32
6.4	LOW NOISE, FULLY INTEGRATED VCO	15	8.8	OSCin INPUT	36
6.5	CLKout DELAYS	15	8.9	MORE THAN EIGHT OUTPUTS WITH AN LMK03000 FAMILY DEVICE	37
6.6	LVDS/LVPECL OUTPUTS	16	Revision History	38	
6.7	GLOBAL CLOCK OUTPUT SYNCHRONIZATION	16			
6.8	CLKout OUTPUT STATES	17			
6.9	GLOBAL OUTPUT ENABLE AND LOCK DETECT	17			

2 Device Information

2.1 Functional Block Diagram

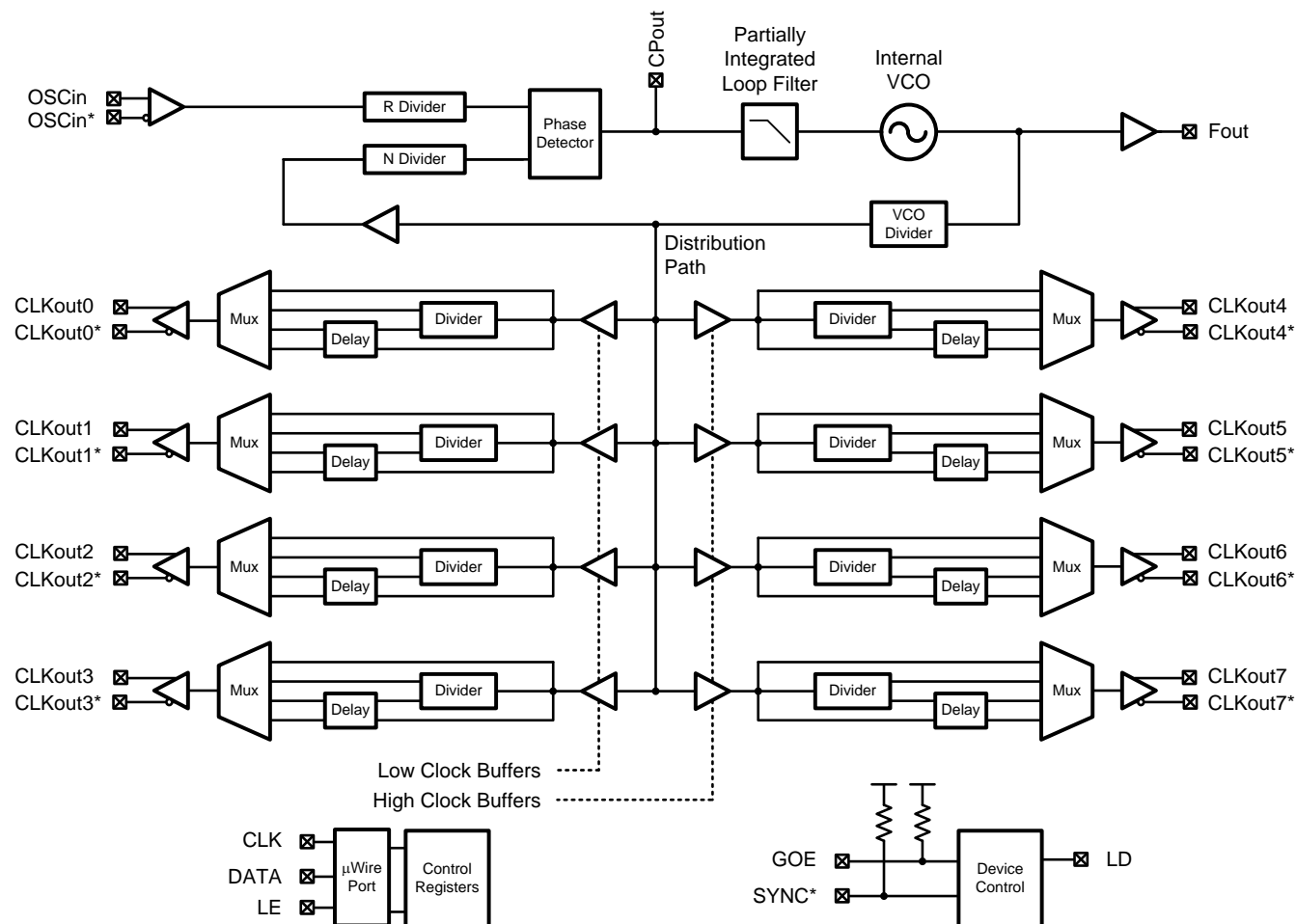

2.2 Connection Diagram

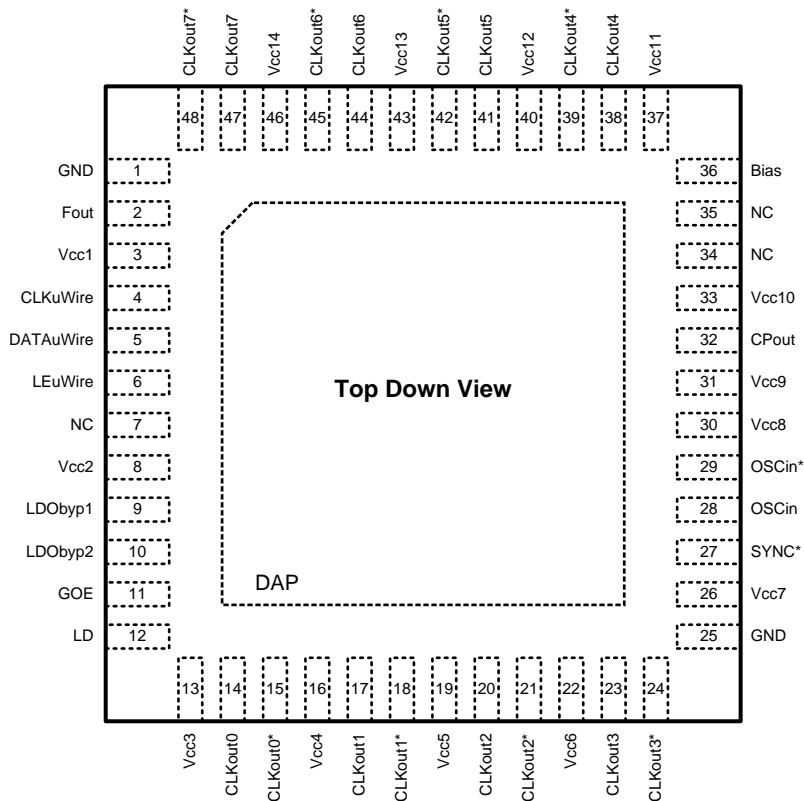

Figure 2-1. 48-Pin WQFN Package

Table 2-1. PIN DESCRIPTIONS

Pin #	Pin Name	I/O	Description
1, 25	GND	-	Ground
2	Fout	O	Internal VCO Frequency Output
3, 8, 13, 16, 19, 22, 26, 30, 31, 33, 37, 40, 43, 46	Vcc1, Vcc2, Vcc3, Vcc4, Vcc5, Vcc6, Vcc7, Vcc8, Vcc9, Vcc10, Vcc11, Vcc12, Vcc13, Vcc14	-	Power Supply
4	CLKuWire	I	MICROWIRE Clock Input
5	DATAuWire	I	MICROWIRE Data Input
6	LEuWire	I	MICROWIRE Latch Enable Input
7, 34, 35	NC	-	No Connection to these pins
9, 10	LDObyp1, LDObyp2	-	LDO Bypass
11	GOE	I	Global Output Enable
12	LD	O	Lock Detect and Test Output
14, 15	CLKout0, CLKout0*	O	LVDS Clock Output 0
17, 18	CLKout1, CLKout1*	O	LVDS Clock Output 1
20, 21	CLKout2, CLKout2*	O	LVDS Clock Output 2
23, 24	CLKout3, CLKout3*	O	Clock Output 3 (LVDS for LMK03033C/LMK03033 LVPECL for all other parts)
27	SYNC*	I	Global Clock Output Synchronization
28, 29	OScin, OSCin*	I	Oscillator Clock Input; Should be AC coupled
32	CPout	O	Charge Pump Output
36	Bias	I	Bias Bypass
38, 39	CLKout4, CLKout4*	O	LVPECL Clock Output 4
41, 42	CLKout5, CLKout5*	O	LVPECL Clock Output 5
44, 45	CLKout6, CLKout6*	O	LVPECL Clock Output 6
47, 48	CLKout7, CLKout7*	O	LVPECL Clock Output 7
DAP	DAP	-	Die Attach Pad is Ground



These devices have limited built-in ESD protection. The leads should be shorted together or the device placed in conductive foam during storage or handling to prevent electrostatic damage to the MOS gates.

3 Electrical Specifications

3.1 Absolute Maximum Ratings⁽¹⁾⁽²⁾⁽³⁾

Parameter	Symbol	Ratings	Units
Power Supply Voltage	V_{CC}	-0.3 to 3.6	V
Input Voltage	V_{IN}	-0.3 to ($V_{CC} + 0.3$)	V
Storage Temperature Range	T_{STG}	-65 to 150	°C
Lead Temperature (solder 4 s)	T_L	+260	°C
Junction Temperature	T_J	125	°C

- (1) "Absolute Maximum Ratings" indicate limits beyond which damage to the device may occur, including inoperability and degradation of device reliability and/or performance. Functional operation of the device and/or non-degradation at the Absolute Maximum Ratings or other conditions beyond those indicated in the Recommended Operating Conditions is not implied. The Recommended Operating Conditions indicate conditions at which the device is functional and the device should not be operated beyond such conditions.
- (2) This device is a high performance integrated circuit with ESD handling precautions. Handling of this device should only be done at ESD protected work stations. The device is rated to a HBM-ESD of > 2 kV, a MM-ESD of > 200 V, and a CDM-ESD of > 1.2 kV.
- (3) If Military/Aerospace specified devices are required, please contact the Texas Instruments Sales Office/Distributors for availability and specifications.

3.2 Recommended Operating Conditions

Parameter	Symbol	Min	Typ	Max	Units
Ambient Temperature	T_A	-40	25	85	°C
Power Supply Voltage	V_{CC}	3.15	3.3	3.45	V

3.3 Package Thermal Resistance

Package	θ_{JA}	θ_{J-PAD} (Thermal Pad)
48-Lead WQFN ⁽¹⁾	27.4° C/W	5.8° C/W

- (1) Specification assumes 16 thermal vias connect the die attach pad to the embedded copper plane on the 4-layer JEDEC board. These vias play a key role in improving the thermal performance of the WQFN. It is recommended that the maximum number of vias be used in the board layout.

3.4 Electrical Characteristics ⁽¹⁾

(3.15 V ≤ V_{CC} ≤ 3.45 V, -40 °C ≤ T_A ≤ 85 °C, Differential Inputs/Outputs; V_{boost}=0; except as specified. Typical values represent most likely parametric norms at V_{CC} = 3.3 V, T_A = 25 °C, and at the Recommended Operation Conditions at the time of product characterization and are not ensured).

Symbol	Parameter	Conditions	Min	Typ	Max	Units
Current Consumption						
I _{CC}	Power Supply Current ⁽²⁾	Entire device; one LVDS and one LVPECL clock enabled; no divide; no delay.		161.8		mA
		Entire device; All Outputs Off (no emitter resistors placed)		86		
I _{CCPD}	Power Down Current	POWERDOWN = 1		1		mA
Reference Oscillator						
f _{OSCin} square	Reference Oscillator Input Frequency Range for Square Wave	AC coupled; Differential (V _{OD})	1		200	MHz
V _{OSCin} square	Square Wave Input Voltage for OSCin and OSCin*		0.2		1.6	V _{pp}
PLL						
f _{PD}	Phase Detector Frequency				40	MHz
I _{SOURCEPout}	Charge Pump Source Current	V _{CPout} = V _{CC} /2, PLL_CP_GAIN = 1x		100		μA
		V _{CPout} = V _{CC} /2, PLL_CP_GAIN = 4x		400		
		V _{CPout} = V _{CC} /2, PLL_CP_GAIN = 16x		1600		
		V _{CPout} = V _{CC} /2, PLL_CP_GAIN = 32x		3200		
I _{SINKCPout}	Charge Pump Sink Current	V _{CPout} = V _{CC} /2, PLL_CP_GAIN = 1x		-100		μA
		V _{CPout} = V _{CC} /2, PLL_CP_GAIN = 4x		-400		
		V _{CPout} = V _{CC} /2, PLL_CP_GAIN = 16x		-1600		
		V _{CPout} = V _{CC} /2, PLL_CP_GAIN = 32x		-3200		
I _{CPout} TRI	Charge Pump TRI-STATE Current	0.5 V < V _{CPout} < V _{CC} - 0.5 V		2	10	nA
I _{CPout} %MIS	Magnitude of Charge Pump Sink vs. Source Current Mismatch	V _{CPout} = V _{CC} / 2 T _A = 25°C		3		%
I _{CPout} VTUNE	Magnitude of Charge Pump Current vs. Charge Pump Voltage Variation	0.5 V < V _{CPout} < V _{CC} - 0.5 V T _A = 25°C		4		%
I _{CPout} TEMP	Magnitude of Charge Pump Current vs. Temperature Variation			4		%
PN10kHz	PLL 1/f Noise at 10 kHz Offset ⁽³⁾ Normalized to 1 GHz Output Frequency	PLL_CP_GAIN = 1x		-117		dBc/Hz
		PLL_CP_GAIN = 32x		-122		
PN1Hz	Normalized Phase Noise Contribution ⁽⁴⁾	PLL_CP_GAIN = 1x		-219		dBc/Hz
		PLL_CP_GAIN = 32x		-224		

- (1) The Electrical Characteristics table lists ensured specifications under the listed Recommended Operating Conditions except as otherwise modified or specified by the Electrical Characteristics Conditions and/or Notes. Typical specifications are estimations only and are not ensured.
- (2) See [Section 8.5](#) for more current consumption / power dissipation calculation information.
- (3) A specification in modeling PLL in-band phase noise is the 1/f flicker noise, L_{PLL_flicker}(f), which is dominant close to the carrier. Flicker noise has a 10 dB/decade slope. PN10kHz is normalized to a 10 kHz offset and a 1 GHz carrier frequency. PN10kHz = L_{PLL_flicker}(10 kHz) - 20log(Fout / 1 GHz), where L_{PLL_flicker}(f) is the single side band phase noise of only the flicker noise's contribution to total noise, L(f). To measure L_{PLL_flicker}(f) it is important to be on the 10 dB/decade slope close to the carrier. A high compare frequency and a clean crystal are important to isolating this noise source from the total phase noise, L(f). L_{PLL_flicker}(f) can be masked by the reference oscillator performance if a low power or noisy source is used. The total PLL inband phase noise performance is the sum of L_{PLL_flicker}(f) and L_{PLL_flat}(f).
- (4) A specification in modeling PLL in-band phase noise is the Normalized Phase Noise Contribution, L_{PLL_flat}(f), of the PLL and is defined as PN1Hz = L_{PLL_flat}(f) - 20log(N) - 10log(f_{COMP}). L_{PLL_flat}(f) is the single side band phase noise measured at an offset frequency, f, in a 1 Hz Bandwidth and f_{COMP} is the phase detector frequency of the synthesizer. L_{PLL_flat}(f) contributes to the total noise, L(f). To measure L_{PLL_flat}(f) the offset frequency, f, must be chosen sufficiently smaller than the loop bandwidth of the PLL, and yet large enough to avoid a substantial noise contribution from the reference and flicker noise. L_{PLL_flat}(f) can be masked by the reference oscillator performance if a low power or noisy source is used.

Electrical Characteristics ⁽¹⁾ (continued)

(3.15 V ≤ V_{CC} ≤ 3.45 V, -40 °C ≤ T_A ≤ 85 °C, Differential Inputs/Outputs; V_{boost}=0; except as specified. Typical values represent most likely parametric norms at V_{CC} = 3.3 V, T_A = 25 °C, and at the Recommended Operation Conditions at the time of product characterization and are not ensured).

Symbol	Parameter	Conditions	Min	Typ	Max	Units
VCO						
f _{Fout}	VCO Tuning Range	LMK03000C/LMK03000/LMK03000D	1185		1296	MHz
		LMK03001C/LMK03001/LMK03001D	1470		1570	
		LMK03033C/LMK03033	1843		2160	
ΔT _{CL}	Allowable Temperature Drift for Continuous Lock	After programming R15 for lock, no changes to output configuration are permitted to ensure continuous lock. ⁽¹⁾			125	°C
P _{Fout}	Output Power to a 50 Ω load driven by F _{out} ⁽²⁾	LMK03000C/LMK03000/LMK03000D; T _A = 25 °C		3.3		dBm
		LMK03001C/LMK03001/LMK03001D; T _A = 25 °C		2.7		
		LMK03033C/LMK03033; T _A = 25 °C		-5 to 0		
K _{VCO}	Fine Tuning Sensitivity ⁽³⁾	LMK03000C/LMK03000/LMK03000D		7 to 9		MHz/V
		LMK03001C/LMK03001/LMK03001D		9 to 11		
		LMK03033C/LMK03033		14 to 26		
J _{RMS} F _{out}	F _{out} RMS Period Jitter (12 kHz to 20 MHz bandwidth)	LMK03000C/LMK03001C		400		fs
		LMK03000/LMK03001		800		
		LMK03000D/LMK03001D		1200		
		LMK03033C		500		
		LMK03033		800		

- (1) Allowable Temperature Drift for Continuous Lock is how far the temperature can drift in either direction and stay in lock from the ambient temperature and programmed state at which the device was when register R15 was programmed. The action of programming the R15 register, even to the same value, activates a frequency calibration routine. This implies that the device will work over the entire frequency range, but if the temperature drifts more than the maximum allowable drift for continuous lock, then it will be necessary to reprogram the R15 register to ensure that the device stays in lock. Regardless of what temperature the device was initially programmed at, the ambient temperature can never drift outside the range of -40 °C ≤ T_A ≤ 85 °C without violating specifications. For this specification to be valid, the programmed state of the device must not change after R15 is programmed.
- (2) Output power varies as a function of frequency. When a range is shown, the higher output power applies to the lower frequency and the lower output power applies to the higher frequency.
- (3) The lower sensitivity indicates the typical sensitivity at the lower end of the tuning range, the higher sensitivity at the higher end of the tuning range

Electrical Characteristics ⁽¹⁾ (continued)

(3.15 V ≤ V_{CC} ≤ 3.45 V, -40 °C ≤ T_A ≤ 85 °C, Differential Inputs/Outputs; V_{boost}=0; except as specified. Typical values represent most likely parametric norms at V_{CC} = 3.3 V, T_A = 25 °C, and at the Recommended Operation Conditions at the time of product characterization and are not ensured).

Symbol	Parameter	Conditions	Min	Typ	Max	Units
VCO (Continued)						
L(f) _{Fout}	F _{out} Single Side Band Phase Noise	LMK03000C f _{Fout} = 1296 MHz ⁽¹⁾	10 kHz Offset	-91.4		dBc/Hz
			100 kHz Offset	-116.8		
			1 MHz Offset	-137.8		
			10 MHz Offset	-156.9		
		LMK03000C f _{Fout} = 1185 MHz ⁽¹⁾	10 kHz Offset	-93.5		
			100 kHz Offset	-118.5		
			1 MHz Offset	-139.4		
			10 MHz Offset	-158.4		
		LMK03001C f _{Fout} = 1570 MHz ⁽¹⁾	10 kHz Offset	-89.6		
			100 kHz Offset	-115.2		
			1 MHz Offset	-136.5		
			10 MHz Offset	-156.0		
		LMK03001C f _{Fout} = 1470 MHz ⁽¹⁾	10 kHz Offset	-91.6		
			100 kHz Offset	-116.0		
			1 MHz Offset	-137.9		
			10 MHz Offset	-156.2		
		LMK03033C f _{Fout} = 2160 MHz ⁽¹⁾	10 kHz Offset	-83		
			100 kHz Offset	-109		
			1 MHz Offset	-131		
			10 MHz Offset	-152		
		LMK03033C f _{Fout} = 1843 MHz ⁽¹⁾	10 kHz Offset	-86		
			100 kHz Offset	-111		
			1 MHz Offset	-134		
			10 MHz Offset	-153		

(1) VCO phase noise is measured assuming the VCO is the dominant noise source due to a 75 Hz loop bandwidth. Over frequency, the phase noise typically varies by 1 to 2 dB, with the worst case performance typically occurring at the highest frequency. Over temperature, the phase noise typically varies by 1 to 2 dB, assuming the device is not reprogrammed. Reprogramming R15 will run the frequency calibration routine for optimum phase noise.

Electrical Characteristics ⁽¹⁾ (continued)

(3.15 V ≤ V_{CC} ≤ 3.45 V, -40 °C ≤ T_A ≤ 85 °C, Differential Inputs/Outputs; V_{boost}=0; except as specified. Typical values represent most likely parametric norms at V_{CC} = 3.3 V, T_A = 25 °C, and at the Recommended Operation Conditions at the time of product characterization and are not ensured).

Symbol	Parameter	Conditions	Min	Typ	Max	Units
Clock Distribution Section ⁽¹⁾ (2) - LVDS Clock Outputs						
Jitter _{ADD}	Additive RMS Jitter ⁽¹⁾	R _L = 100 Ω Distribution Path = 765 MHz Bandwidth = 12 kHz to 20 MHz		20		fs
		CLKoutX_MUX = Bypass (no divide or delay) CLKoutX_MUX = Divided (no delay) CLKoutX_DIV = 4		75		
t _{SKEW}	CLKoutX to CLKoutY ⁽³⁾	Equal loading and identical clock configuration R _L = 100 Ω	-30	±4	30	ps
V _{OD}	Differential Output Voltage	R _L = 100 Ω	250	350	450	mV
ΔV _{OD}	Change in magnitude of V _{OD} for complementary output states	R _L = 100 Ω	-50		50	mV
V _{OS}	Output Offset Voltage	R _L = 100 Ω	1.070	1.25	1.370	V
ΔV _{OS}	Change in magnitude of V _{OS} for complementary output states	R _L = 100 Ω	-35		35	mV
I _{SA} I _{SB}	Clock Output Short Circuit Current single-ended	Single-ended outputs shorted to GND	-24		24	mA
I _{SAB}	Clock Output Short Circuit Current differential	Complementary outputs tied together	-12		12	mA
Clock Distribution Section ⁽¹⁾ (2) - LVPECL Clock Outputs						
Jitter _{ADD}	Additive RMS Jitter ⁽¹⁾	R _L = 100 Ω Distribution Path = 765 MHz Bandwidth = 12 kHz to 20 MHz		20		fs
		CLKoutX_MUX = Bypass (no divide or delay) CLKoutX_MUX = Divided (no delay) CLKoutX_DIV = 4		75		
t _{SKEW}	CLKoutX to CLKoutY ⁽³⁾	Equal loading and identical clock configuration Termination = 50 Ω to V _{CC} - 2 V	-30	±3	30	ps
V _{OH}	Output High Voltage	Termination = 50 Ω to V _{CC} - 2 V		V _{CC} - 0.98		V
V _{OL}	Output Low Voltage			V _{CC} - 1.8		V
V _{OD}	Differential Output Voltage	R _L = 100 Ω	660	810	965	mV
Digital LVTTTL Interfaces ⁽⁴⁾						
V _{IH}	High-Level Input Voltage		2.0		V _{CC}	V
V _{IL}	Low-Level Input Voltage				0.8	V
I _{IH}	High-Level Input Current	V _{IH} = V _{CC}	-5.0		5.0	μA
I _{IL}	Low-Level Input Current	V _{IL} = 0	-40.0		5.0	μA
V _{OH}	High-Level Output Voltage	I _{OH} = +500 μA	V _{CC} - 0.4			V
V _{OL}	Low-Level Output Voltage	I _{OL} = -500 μA			0.4	V

- (1) The Clock Distribution Section includes all parts of the device except the PLL and VCO sections. Typical Additive Jitter specifications apply to the clock distribution section only and this adds in an RMS fashion to the shaped jitter of the PLL and the VCO.
- (2) For CLKout frequencies above 1 GHz, the delay should be limited to one half of a period. For 1 GHz and below, the maximum delay can be used.
- (3) Specification is ensured by characterization and is not tested in production.
- (4) Applies to GOE, LD, and SYNC*.

Electrical Characteristics ⁽¹⁾ (continued)

(3.15 V ≤ V_{CC} ≤ 3.45 V, -40 °C ≤ T_A ≤ 85 °C, Differential Inputs/Outputs; V_{boost}=0; except as specified. Typical values represent most likely parametric norms at V_{CC} = 3.3 V, T_A = 25 °C, and at the Recommended Operation Conditions at the time of product characterization and are not ensured).

Symbol	Parameter	Conditions	Min	Typ	Max	Units
Digital MICROWIRE Interfaces ⁽¹⁾						
V _{IH}	High-Level Input Voltage		1.6		V _{CC}	V
V _{IL}	Low-Level Input Voltage				0.4	V
I _{IH}	High-Level Input Current	V _{IH} = V _{CC}	-5.0		5.0	μA
I _{IL}	Low-Level Input Current	V _{IL} = 0	-5.0		5.0	μA
MICROWIRE Timing						
t _{CS}	Data to Clock Set Up Time	See Data Input Timing	25			ns
t _{CH}	Data to Clock Hold Time	See Data Input Timing	8			ns
t _{CWH}	Clock Pulse Width High	See Data Input Timing	25			ns
t _{CWL}	Clock Pulse Width Low	See Data Input Timing	25			ns
t _{ES}	Clock to Enable Set Up Time	See Data Input Timing	25			ns
t _{CES}	Enable to Clock Set Up Time	See Data Input Timing	25			ns
t _{EWH}	Enable Pulse Width High	See Data Input Timing	25			ns

(1) Applies to CLKuWire, DATAuWire, and LEuWire.

3.5 Serial Data Timing Diagram

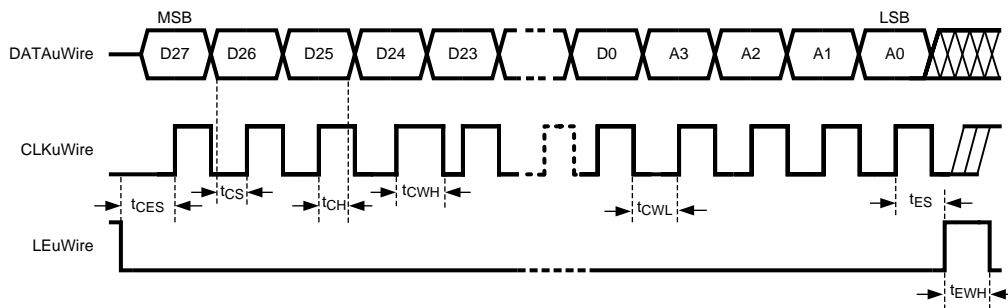

Data bits set on the DATAuWire signal are clocked into a shift register, MSB first, on each rising edge of the CLKuWire signal. On the rising edge of the LEuWire signal, the data is sent from the shift register to the addressed register determined by the LSB bits. After the programming is complete the CLKuWire, DATAuWire, and LEuWire signals should be returned to a low state. It is recommended that the slew rate of CLKuWire, DATAuWire, and LEuWire should be at least 30 V/μs.

4 Measurement Definitions

4.1 Charge Pump Current Specification Definitions

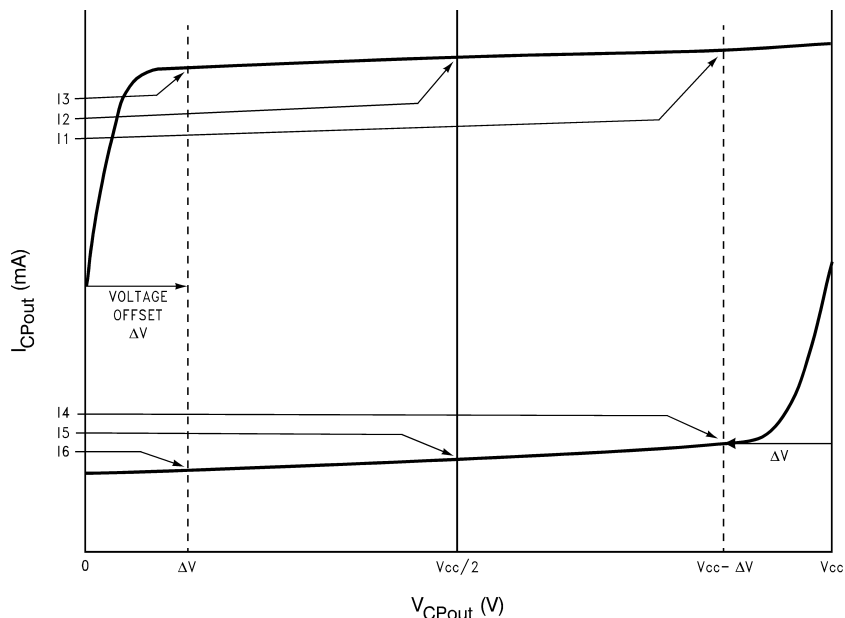

I1 = Charge Pump Sink Current at $V_{CPout} = V_{CC} - \Delta V$

I2 = Charge Pump Sink Current at $V_{CPout} = V_{CC}/2$

I3 = Charge Pump Sink Current at $V_{CPout} = \Delta V$

I4 = Charge Pump Source Current at $V_{CPout} = V_{CC} - \Delta V$

I5 = Charge Pump Source Current at $V_{CPout} = V_{CC}/2$

I6 = Charge Pump Source Current at $V_{CPout} = \Delta V$

ΔV = Voltage offset from the positive and negative supply rails. Defined to be 0.5 V for this device.

4.1.1 Charge Pump Output Current Magnitude Variation vs. Charge Pump Output Voltage

$$I_{CPout} \text{ Vs } V_{CPout} = \frac{|I1| - |I3|}{|I1| + |I3|} \times 100\%$$

$$= \frac{|I4| - |I6|}{|I4| + |I6|} \times 100\%$$

4.1.2 Charge Pump Sink Current vs. Charge Pump Output Source Current Mismatch

$$I_{CPout} \text{ Sink Vs } I_{CPout} \text{ Source} = \frac{|I2| - |I5|}{|I2| + |I5|} \times 100\%$$

4.1.3 Charge Pump Output Current Magnitude Variation vs. Temperature

$$I_{CPout} \text{ Vs } T_A = \frac{|I2|_{T_A} - |I2|_{T_A=25^\circ C}}{|I2|_{T_A=25^\circ C}} \times 100\%$$

$$= \frac{|I5|_{T_A} - |I5|_{T_A=25^\circ C}}{|I5|_{T_A=25^\circ C}} \times 100\%$$

5 Typical Performance Characteristics

NOTE

These plots show performance at frequencies beyond what the part is ensured to operate at to give the user an idea of the capabilities of the part, but they do not imply any sort of ensured specification.

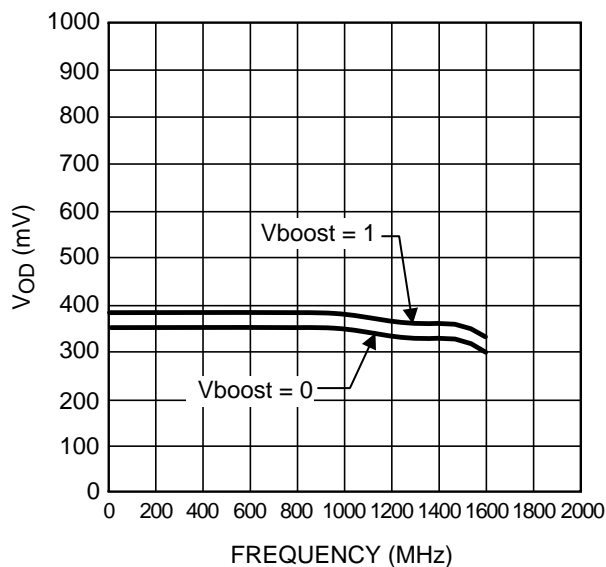

Figure 5-1. LVDS Differential Output Voltage (V_{od})

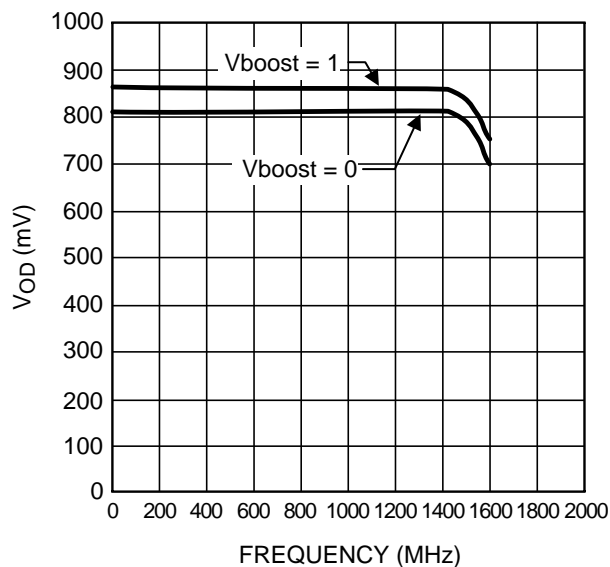

Figure 5-2. LVPECL Differential Output Voltage (V_{od})

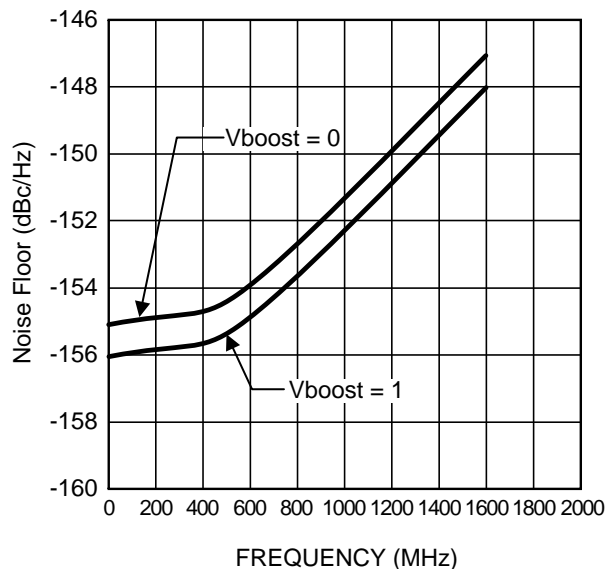

Figure 5-3. LVDS Output Buffer Noise Floor

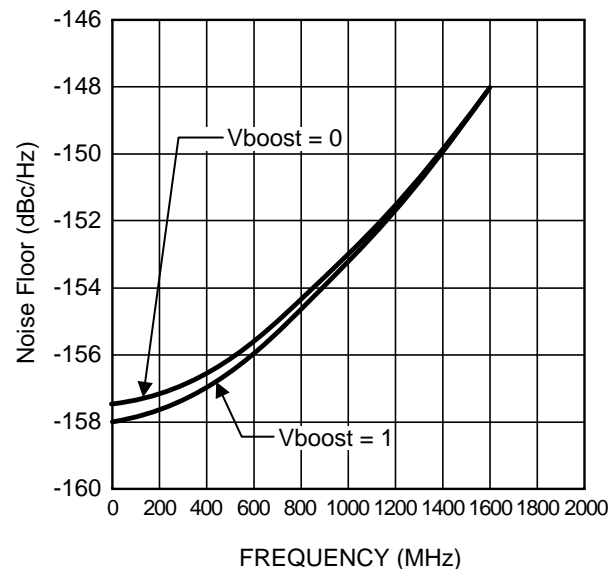
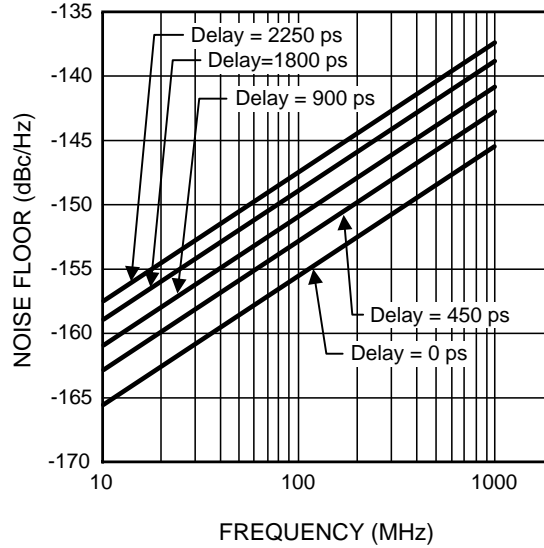

Figure 5-4. LVPECL Output Buffer Noise Floor

To estimate this noise, only the output frequency is required. Divide value and input frequency are not integral.

To estimate this noise, only the output frequency is required. Divide value and input frequency are not integral.



To estimate this noise, only the output frequency is required. Divide value and input frequency are not integral. The noise of the delay block is independent of output type and only applies if the delay is enabled. The noise floor due to the distribution section accounting for the delay noise can be calculated as: Total Output Noise = $10 \times \log(10^{\text{Output Buffer Noise}/10} + 10^{\text{Delay Noise Floor}/10})$.

Figure 5-5. Delay Noise Floor (Adds to Output Noise Floor)

6 Functional Description

The LMK03000 family of precision clock conditioners combine the functions of jitter cleaning/reconditioning, multiplication, and distribution of a reference clock. The devices integrate a Voltage Controlled Oscillator (VCO), a high performance Integer-N Phase Locked Loop (PLL), a partially integrated loop filter, three LVDS, and five LVPECL clock output distribution blocks.

The devices include internal 3rd and 4th order poles to simplify loop filter design and improve spurious performance. The 1st and 2nd order poles are off-chip to provide flexibility for the design of various loop filter bandwidths.

The LMK03000 family has multiple options for VCO frequencies. The VCO output is optionally accessible on the Fout port. Internally, the VCO output goes through an VCO Divider to feed the various clock distribution blocks.

Each clock distribution block includes a programmable divider, a phase synchronization circuit, a programmable delay, a clock output mux, and an LVDS or LVPECL output buffer. This allows multiple integer-related and phase-adjusted copies of the reference to be distributed to eight system components.

The clock conditioners come in a 48-pin WQFN package and are footprint compatible with other clocking devices in the same family.

6.1 BIAS PIN

To properly use the device, bypass Bias (pin 36) with a low leakage 1 μ F capacitor connected to Vcc. This is important for low noise performance.

6.2 LDO BYPASS

To properly use the device, bypass LDObyp1 (pin 9) with a 10 μ F capacitor and LDObyp2 (pin 10) with a 0.1 μ F capacitor.

6.3 OSCILLATOR INPUT PORT (OSCI_{in}, OSCI_{in}*)

The purpose of OSCI_{in} is to provide the PLL with a reference signal. Due to an internal DC bias the OSCI_{in} port should be AC coupled, refer to the [Section 8.1](#) in the [Section 8](#) section. The OSCI_{in} port may be driven single-endedly by AC grounding OSCI_{in}* with a 0.1 μ F capacitor.

6.4 LOW NOISE, FULLY INTEGRATED VCO

The LMK03000 family of devices contain a fully integrated VCO. In order for proper operation the VCO uses a frequency calibration algorithm. The frequency calibration algorithm is activated any time that the R15 register is programmed. Once R15 is programmed the temperature may not drift more than the maximum allowable drift for continuous lock, ΔT_{CL} , or else the VCO is not ensured to stay in lock.

For the frequency calibration algorithm to work properly OSCI_{in} must be driven by a valid signal when R15 is programmed.

6.5 CLKout DELAYS

Each individual clock output includes a delay adjustment. Clock output delay registers (CLKoutX_DLY) support a 150 ps step size and range from 0 to 2250 ps of total delay.

6.6 LVDS/LVPECL OUTPUTS

By default all the clock outputs are disabled until programmed.

Each LVDS or LVPECL output may be disabled individually by programming the CLKoutX_EN bits. All the outputs may be disabled simultaneously by pulling the GOE pin low or programming EN_CLKout_Global to 0.

The duty cycle of the LVDS and LVPECL clock outputs are shown in the table below.

VCO_DIV	CLKoutX_MUX	Duty Cycle
Any	Divided, or Divided and Delayed	50%
2, 4, 6, 8	Any	50%
3	Bypassed, or Delayed	33%
5	Bypassed, or Delayed	40%
7	Bypassed, or Delayed	43%

6.7 GLOBAL CLOCK OUTPUT SYNCHRONIZATION

The SYNC* pin synchronizes the clock outputs. When the SYNC* pin is held in a logic low state, the divided outputs are also held in a logic low state. The bypassed outputs will continue to operate normally. Shortly after the SYNC* pin goes high, the divided clock outputs are activated and will all transition to a high state simultaneously. All the outputs, divided and bypassed, will now be synchronized. Clocks in the bypassed state are not affected by SYNC* and are always synchronized with the divided outputs.

The SYNC* pin must be held low for greater than one clock cycle of the output of the VCO Divider, also known as the distribution path. Once this low event has been registered, the outputs will not reflect the low state for four more cycles. This means that the outputs will be low on the fifth rising edge of the distribution path. Similarly once the SYNC* pin becomes high, the outputs will not simultaneously transition high until four more distribution path clock cycles have passed, which is the fifth rising edge of the distribution path. See the timing diagram in Figure 6-1 for further detail. The clocks are programmed as CLKout0_MUX = Bypassed, CLKout1_MUX = Divided, CLKout1_DIV = 2, CLKout2_MUX = Divided, and CLKout2_DIV = 4. To synchronize the outputs, after the low SYNC* event has been registered, it is not required to wait for the outputs to go low before SYNC* is set high.

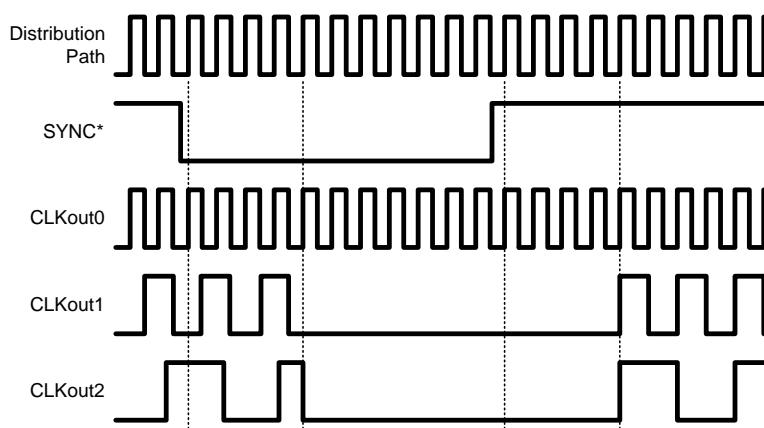

Figure 6-1. SYNC* Timing Diagram

The SYNC* pin provides an internal pull-up resistor as shown on the functional block diagram. If the SYNC* pin is not terminated externally the clock outputs will operate normally. If the SYNC* function is not used, clock output synchronization is not ensured.

6.8 CLKout OUTPUT STATES

Each clock output may be individually enabled with the CLKoutX_EN bits. Each individual output enable control bit is gated with the Global Output Enable input pin (GOE) and the Global Output Enable bit (EN_CLKout_Global).

All clock outputs can be disabled simultaneously if the GOE pin is pulled low by an external signal or EN_CLKout_Global is set to 0.

CLKoutX_EN bit	EN_CLKout_Global bit	GOE pin	CLKoutX Output State
1	1	Low	Low
Don't care	0	Don't care	Off
0	Don't care	Don't care	Off
1	1	High / No Connect	Enabled

When an LVDS output is in the Off state, the outputs are at a voltage of approximately 1.5 volts. When an LVPECL output is in the Off state, the outputs are at a voltage of approximately 1 volt.

6.9 GLOBAL OUTPUT ENABLE AND LOCK DETECT

The GOE pin provides an internal pull-up resistor as shown on the functional block diagram. If it is not terminated externally, the clock output states are determined by the Clock Output Enable bits (CLKoutX_EN) and the EN_CLKout_Global bit.

By programming the PLL_MUX register to Digital Lock Detect Active High, the Lock Detect (LD) pin can be connected to the GOE pin in which case all outputs are set low automatically if the synthesizer is not locked.

6.10 POWER ON RESET

When supply voltage to the device increases monotonically from ground to Vcc, the power on reset circuit sets all registers to their default values, see the [Section 7](#) section for more information on default register values. Voltage should be applied to all Vcc pins simultaneously.

6.11 DIGITAL LOCK DETECT

The PLL digital lock detect circuitry compares the difference between the phase of the inputs of the phase detector to a RC generated delay of ϵ . To indicate a locked state the phase error must be less than the ϵ RC delay for 5 consecutive reference cycles. Once in lock, the RC delay is changed to approximately δ . To indicate an out of lock state, the phase error must become greater δ . The values of ϵ and δ are shown in the table below:

ϵ	δ
10 ns	20 ns

To utilize the digital lock detect feature, PLL_MUX must be programmed for "Digital Lock Detect (Active High)" or "Digital Lock Detect (Active Low)." When one of these modes is programmed the state of the LD pin will be set high or low as determined by the description above as shown in Figure 6-2.

When the device is in power down mode and the LD pin is programmed for a digital lock detect function, LD will show a "no lock detected" condition which is low or high given active high or active low circuitry respectively.

The accuracy of this circuit degrades at higher comparison frequencies. To compensate for this, the DIV4 word should be set to one if the comparison frequency exceeds 20 MHz. The function of this word is to divide the comparison frequency presented to the lock detect circuit by 4.

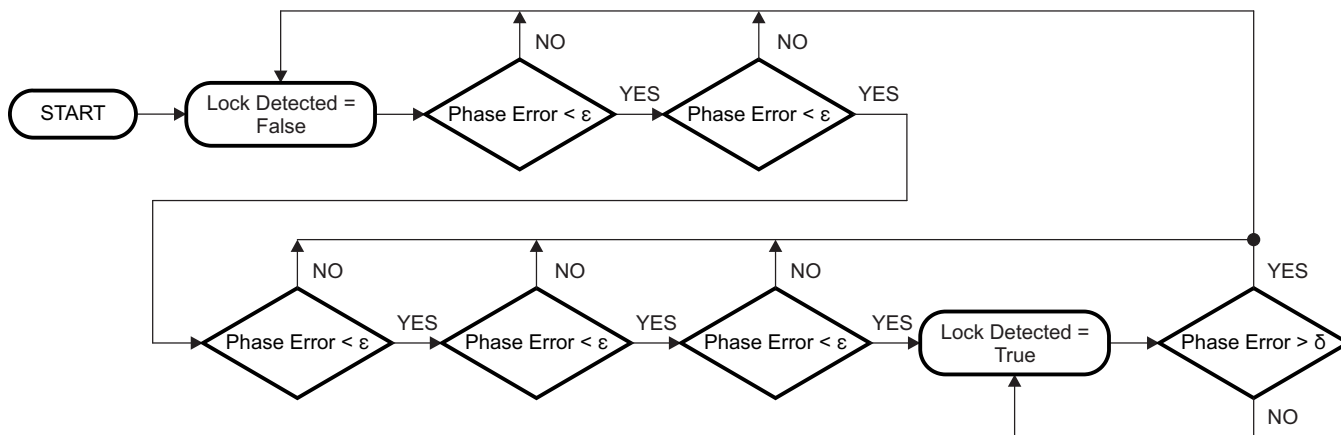

Figure 6-2. Digital Lock Detect Flowchart

7 General Programming Information

The LMK03000 family of devices are programmed using several 32-bit registers which control the device's operation. The registers consist of a data field and an address field. The last 4 register bits, ADDR[3:0] form the address field. The remaining 28 bits form the data field DATA[27:0].

During programming, LEuWire is low and serial data is clocked in on the rising edge of CLKuWire (MSB first). When LE goes high, data is transferred to the register bank selected by the address field. Only registers R0 to R7, R11, and R13 to R15 need to be programmed for proper device operation.

For the frequency calibration algorithm to work properly OSCin must be driven by a valid signal when R15 is programmed. Any changes to the PLL R divider or OSCin require R15 to be programmed again to activate the frequency calibration routine.

7.1 RECOMMENDED PROGRAMMING SEQUENCE

The recommended programming sequence involves programming R0 with the reset bit set (RESET = 1) to ensure the device is in a default state. It is not necessary to program R0 again, but if R0 is programmed again, the reset bit is programmed clear (RESET = 0). Registers are programmed in order with R15 being the last register programmed. An example programming sequence is shown below.

- Program R0 with the reset bit set (RESET = 1). This ensures the device is in a default state. When the reset bit is set in R0, the other R0 bits are ignored.
 - If R0 is programmed again, the reset bit is programmed clear (RESET = 0).
- Program R0 to R7 as necessary with desired clocks with appropriate enable, mux, divider, and delay settings.
- Program R8 for optimum phase noise performance.
- Program R9 with Vboost setting if necessary. Optional, only needed to set Vboost = 1.
- Program R11 with DIV4 setting if necessary.
- Program R13 with oscillator input frequency and internal loop filter values
- Program R14 with Fout enable bit, global clock output bit, power down setting, PLL mux setting, and PLL R divider.
- Program R15 with PLL charge pump gain, VCO divider, and PLL N divider. Also starts frequency calibration routine.

Table 7-1. REGISTER MAP

Register	31	30	29	28	27	26	25	24	23	22	21	20	19	18	17	16	15	14	13	12	11	10	9	8	7	6	5	4	3	2	1	0
	Data [27:0]																											A3	A2	A1	A0	
R0	RESET	0	0	0	0	0	0	0	0	0	0	0	0	0	0	0	0	0	0	0	0	0	0	0	0	0	0	0	0	0	0	0
R1	0	0	0	0	0	0	0	0	0	0	0	0	0	0	0	0	0	0	0	0	0	0	0	0	0	0	0	0	0	0	0	1
R2	0	0	0	0	0	0	0	0	0	0	0	0	0	0	0	0	0	0	0	0	0	0	0	0	0	0	0	0	0	1	0	0
R3	0	0	0	0	0	0	0	0	0	0	0	0	0	0	0	0	0	0	0	0	0	0	0	0	0	0	0	0	0	1	1	0
R4	0	0	0	0	0	0	0	0	0	0	0	0	0	0	0	0	0	0	0	0	0	0	0	0	0	0	0	0	0	1	0	0
R5	0	0	0	0	0	0	0	0	0	0	0	0	0	0	0	0	0	0	0	0	0	0	0	0	0	0	0	0	0	1	0	1
R6	0	0	0	0	0	0	0	0	0	0	0	0	0	0	0	0	0	0	0	0	0	0	0	0	0	0	0	0	0	1	1	0
R7	0	0	0	0	0	0	0	0	0	0	0	0	0	0	0	0	0	0	0	0	0	0	0	0	0	0	0	0	0	1	1	1
R8	0	0	0	1	0	0	0	0	0	0	0	0	0	0	0	0	0	0	0	0	1	0	0	1	0	0	0	0	1	0	0	0

Table 7-1. REGISTER MAP (continued)

Register	31	30	29	28	27	26	25	24	23	22	21	20	19	18	17	16	15	14	13	12	11	10	9	8	7	6	5	4	3	2	1	0	
R9	1	0	1	0	0	0	0	0	0	0	0	0	0	0	1	Vboost	0	0	1	0	1	0	1	0	0	0	0	0	0	1	0	0	1
R11	0	0	0	0	0	0	0	0	1	0	0	0	0	0	1	0	DIV4	0	0	0	0	0	0	0	0	0	0	0	1	0	1	1	
R13	0	0	0	0	0	0	1	0	1	0	OSC _{in} _FREQ [7:0]							VCO_R4_LF [2:0]		VCO_R3_LF [2:0]		VCO_C3_C4_LF [3:0]			1	1	0	1					
R14	0	0	0	EN_Fout	EN_CLKout_Global	POWERDOWN	0	0	PLL_MUX [3:0]				PLL_R [11:0]											0	0	0	0	1	1	1	0		
R15	PLL_CP_GAIN [1:0]		VCO_DIV [3:0]			PLL_N [17:0]											0	0	0	0	1	1	1	1									

7.2 REGISTER R0 to R7

Registers R0 through R7 control the eight clock outputs. Register R0 controls CLKout0, Register R1 controls CLKout1, and so on. There is one additional bit in register R0 called RESET. Aside from this, the functions of these bits are identical. The X in CLKoutX_MUX, CLKoutX_DIV, CLKoutX_DLY, and CLKoutX_EN denote the actual clock output which may be from 0 to 7.

Table 7-2. Default Register Settings after Power on Reset

Bit Name	Default Bit Value	Bit State	Bit Description	Register	Bit Location
RESET	0	No reset, normal operation	Reset to power on defaults	R0	31
CLKoutX_MUX	0	Bypassed	CLKoutX mux mode	R0 to R7	18:17
CLKoutX_EN	0	Disabled	CLKoutX enable		16
CLKoutX_DIV	1	Divide by 2	CLKoutX clock divide		15:8
CLKoutX_DLY	0	0 ps	CLKoutX clock delay		7:4
Vboost	0	Normal Mode	Output Power Control	R9	16
DIV4	0	PDF \leq 20 MHz	Phase Detector Frequency	R11	15
OSCI _n _FREQ	10	10 MHz OSC _{in}	OSCI _n Frequency in MHz	R13	21:14
VCO_R4_LF	0	Low (~200 Ω)	R4 internal loop filter values		13:11
VCO_R3_LF	0	Low (~600 Ω)	R3 internal loop filter values		10:8
VCO_C3_C4_LF	0	C3 = 0 pF, C4 = 10 pF	C3 and C4 internal loop filter values		7:4
EN_Fout	0	Fout disabled	Fout enable	R14	28
EN_CLKout_Global	1	Normal - CLKouts normal	Global clock output enable		27
POWERDOWN	0	Normal - Device active	Device power down		26
PLL_MUX	0	Disabled	Multiplexer control for LD pin		23:20
PLL_R	10	R divider = 10	PLL R divide value	R15	19:8
PLL_CP_GAIN	0	100 μ A	Charge pump current		31:30
VCO_DIV	2	Divide by 2	VCO divide value		29:26
PLL_N	760	N divider = 760	PLL N divide value		25:8

7.2.1 RESET bit -- R0 only

This bit is only in register R0. The use of this bit is optional and it should be set to '0' if not used. Setting this bit to a '1' forces all registers to their power on reset condition and therefore automatically clears this bit. If this bit is set, all other R0 bits are ignored and R0 needs to be programmed again if used with its proper values and RESET = 0.

7.2.2 CLKoutX_MUX[1:0] -- Clock Output Multiplexers

These bits control the Clock Output Multiplexer for each clock output. Changing between the different modes changes the blocks in the signal path and therefore incurs a delay relative to the bypass mode. The different MUX modes and associated delays are listed below.

CLKoutX_MUX[1:0]	Mode	Added Delay Relative to Bypass Mode
0	Bypassed (default)	0 ps
1	Divided	100 ps
2	Delayed	400 ps (In addition to the programmed delay)
3	Divided and Delayed	500 ps (In addition to the programmed delay)

7.2.3 CLKoutX_DIV[7:0] -- Clock Output Dividers

These bits control the clock output divider value. In order for these dividers to be active, the respective CLKoutX_MUX bit must be set to either "Divided" or "Divided and Delayed" mode. After all the dividers are programmed, the SYNC* pin must be used to ensure that all edges of the clock outputs are aligned. The Clock Output Dividers follow the VCO Divider so the final clock divide for an output is VCO Divider × Clock Output Divider. By adding the divider block to the output path a fixed delay of approximately 100 ps is incurred.

The actual Clock Output Divide value is twice the binary value programmed as listed in the table below.

CLKoutX_DIV[7:0]								Clock Output Divider value
0	0	0	0	0	0	0	0	Invalid
0	0	0	0	0	0	0	1	2 (default)
0	0	0	0	0	0	1	0	4
0	0	0	0	0	0	1	1	6
0	0	0	0	0	1	0	0	8
0	0	0	0	0	1	0	1	10
.
1	1	1	1	1	1	1	1	510

7.2.4 CLKoutX_DLY[3:0] -- Clock Output Delays

These bits control the delay stages for each clock output. In order for these delays to be active, the respective CLKoutX_MUX (See [Section 7.2.2](#)) bit must be set to either "Delayed" or "Divided and Delayed" mode. By adding the delay block to the output path a fixed delay of approximately 400 ps is incurred in addition to the delay shown in the table below.

CLKoutX_DLY[3:0]	Delay (ps)
0	0 (default)
1	150
2	300
3	450
4	600
5	750
6	900
7	1050
8	1200
9	1350
10	1500
11	1650
12	1800
13	1950
14	2100
15	2250

7.2.5 CLKoutX_EN bit -- Clock Output Enables

These bits control whether an individual clock output is enabled or not. If the EN_CLKout_Global bit (See [Section 7.7.4](#)) is set to zero or if GOE pin is held low, all CLKoutX_EN bit states will be ignored and all clock outputs will be disabled.

CLKoutX_EN bit	Conditions	CLKoutX State
0	EN_CLKout_Global bit = 1 GOE pin = High / No Connect	Disabled (default)
1		Enabled

7.3 REGISTER R8

The programming of register R8 provides optimum phase noise performance.

7.4 REGISTER R9

The programming of register R9 is optional. If it is not programmed the bit Vboost will be defaulted to 0, which is the test condition for all electrical characteristics.

7.4.1 Vboost -- Voltage Boost

By enabling this bit, the voltage output levels for all clock outputs is increased. Also, the noise floor is improved

Vboost	Typical LVDS Voltage Output (mV)	Typical LVPECL Voltage Output (mV)
0	350	810
1	390	865

7.5 REGISTER R11

This register only has one bit and only needs to be programmed in the case that the phase detector frequency is greater than 20 MHz and digital lock detect is used. Otherwise, it is automatically defaulted to the correct values.

7.5.1 DIV4 -- High Phase Detector Frequencies and Lock Detect

This bit divides the frequency presented to the digital lock detect circuitry by 4. It is necessary to get a reliable output from the digital lock detect output in the case of a phase detector frequency frequency greater than 20 MHz.

DIV4	Digital Lock Detect Circuitry Mode
0	Not divided Phase Detector Frequency \leq 20 MHz (default)
1	Divided by 4 Phase Detector Frequency $>$ 20 MHz

7.6 REGISTER R13

7.6.1 VCO_C3_C4_LF[3:0] -- Value for Internal Loop Filter Capacitors C3 and C4

These bits control the capacitor values for C3 and C4 in the internal loop filter.

VCO_C3_C4_LF[3:0]	Loop Filter Capacitors	
	C3 (pF)	C4 (pF)
0	0 (default)	10 (default)
1	0	60
2	50	10
3	0	110
4	50	110
5	100	110
6	0	160
7	50	160
8	100	10
9	100	60
10	150	110
11	150	60
12 to 15	Invalid	

7.6.2 VCO_R3_LF[2:0] -- Value for Internal Loop Filter Resistor R3

These bits control the R3 resistor value in the internal loop filter. The recommended setting for VCO_R3_LF[2:0] = 0 for optimum phase noise and jitter.

VCO_R3_LF[2:0]	R3 Value (kΩ)
0	Low (~600 Ω) (default)
1	10
2	20
3	30
4	40
5 to 7	Invalid

7.6.3 VCO_R4_LF[2:0] -- Value for Internal Loop Filter Resistor R4

These bits control the R4 resistor value in the internal loop filter. The recommended setting for VCO_R4_LF[2:0] = 0 for optimum phase noise and jitter.

VCO_R4_LF[2:0]	R4 Value (kΩ)
0	Low (~200 Ω) (default)
1	10
2	20
3	30
4	40
5 to 7	Invalid

7.6.4 OSCin_FREQ[7:0] -- Oscillator Input Calibration Adjustment

These bits are to be programmed to the OSCin frequency. If the OSCin frequency is not an integral multiple of 1 MHz, then round to the closest value.

OSCin_FREQ[7:0]	OSCin Frequency
1	1 MHz
2	2 MHz
...	...
10	10 MHz (default)
...	...
200	200 MHz
201 to 255	Invalid

7.7 REGISTER R14

7.7.1 PLL_R[11:0] -- R Divider Value

These bits program the PLL R Divider and are programmed in binary fashion. Any changes to PLL_R require R15 to be programmed again to active the frequency calibration routine.

PLL_R[11:0]											PLL R Divide Value	
0	0	0	0	0	0	0	0	0	0	0	0	Invalid
0	0	0	0	0	0	0	0	0	0	0	1	1
0	0	0	0	0	0	0	0	0	0	1	0	2
.
0	0	0	0	0	0	0	0	1	0	1	0	10 (default)
.
1	1	1	1	1	1	1	1	1	1	1	1	4095

7.7.2 PLL_MUX[3:0] -- Multiplexer Control for LD Pin

These bits set the output mode of the LD pin. The table below lists several different modes.

PLL_MUX[3:0]	Output Type	LD Pin Function
0	Hi-Z	Disabled (default)
1	Push-Pull	Logic High
2	Push-Pull	Logic Low
3	Push-Pull	Digital Lock Detect (Active High)
4	Push-Pull	Digital Lock Detect (Active Low)
5	Push-Pull	Analog Lock Detect
6	Open Drain NMOS	Analog Lock Detect
7	Open Drain PMOS	Analog Lock Detect
8		Invalid
9	Push-Pull	N Divider Output/2 (50% Duty Cycle)
10		Invalid
11	Push-Pull	R Divider Output/2 (50% Duty Cycle)
12 to 15		Invalid

7.7.3 POWERDOWN bit -- Device Power Down

This bit can power down the device. Enabling this bit powers down the entire device and all blocks, regardless of the state of any of the other bits or pins.

POWERDOWN bit	Mode
0	Normal Operation (default)
1	Entire Device Powered Down

7.7.4 EN_CLKout_Global bit -- Global Clock Output Enable

This bit overrides the individual CLKoutX_EN bits. When this bit is set to 0, all clock outputs are disabled, regardless of the state of any of the other bits or pins.

EN_CLKout_Global bit	Clock Outputs
0	All Off
1	Normal Operation (default)

7.7.5 EN_Fout bit -- Fout port enable

This bit enables the Fout pin.

EN_Fout bit	Fout Pin Status
0	Disabled (default)
1	Enabled

7.8 REGISTER R15

Programming R15 also activates the frequency calibration routine.

7.8.1 PLL_N[17:0] -- PLL N Divider

These bits program the divide value for the PLL N Divider. The PLL N Divider follows the VCO Divider and precedes the PLL phase detector. Since the VCO Divider is also in the feedback path from the VCO to the PLL Phase Detector, the total N divide value, N_{Total} , is also influenced by the VCO Divider value. $N_{Total} = \text{PLL N Divider} \times \text{VCO Divider}$. The VCO frequency is calculated as, $f_{VCO} = f_{OSCin} \times \text{PLL N Divider} \times \text{VCO Divider} / \text{PLL R Divider}$. Since the PLL N divider is a pure binary counter there are no illegal divide values for PLL_N[17:0] except for 0.

PLL_N[17:0]																	PLL N Divider Value	
0	0	0	0	0	0	0	0	0	0	0	0	0	0	0	0	0	0	Invalid
0	0	0	0	0	0	0	0	0	0	0	0	0	0	0	0	0	1	1
.
0	0	0	0	0	0	0	0	1	0	1	1	1	1	1	0	0	0	760 (default)
.
1	1	1	1	1	1	1	1	1	1	1	1	1	1	1	1	1	1	262143

7.8.2 VCO_DIV[3:0] -- VCO Divider

These bits program the divide value for the VCO Divider. The VCO Divider follows the VCO output and precedes the clock distribution blocks. Since the VCO Divider is in the feedback path from the VCO to the PLL phase detector the VCO Divider contributes to the total N divide value, N_{Total} . $N_{Total} = \text{PLL N Divider} \times \text{VCO Divider}$. The VCO Divider can not be bypassed. See [Section 7.8.1](#) for more information on setting the VCO frequency.

VCO_DIV[3:0]				VCO Divider Value
0	0	0	0	Invalid
0	0	0	1	Invalid
0	0	1	0	2 (default)
0	0	1	1	3
0	1	0	0	4
0	1	0	1	5
0	1	1	0	6
0	1	1	1	7
1	0	0	0	8
1	0	0	1	Invalid
.
1	1	1	1	Invalid

7.8.3 PLL_CP_GAIN[1:0] -- PLL Charge Pump Gain

These bits set the charge pump gain of the PLL.

PLL_CP_GAIN[1:0]	Charge Pump Gain
0	1x (default)
1	4x
2	16x
3	32x

8 Application Information

8.1 SYSTEM LEVEL DIAGRAM

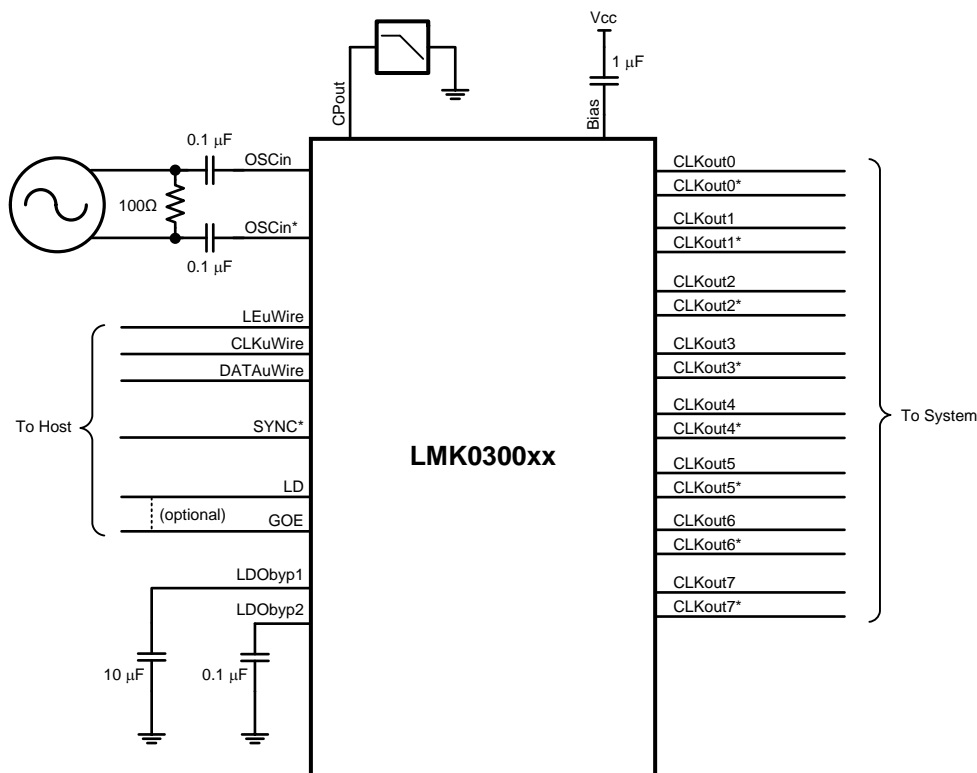

Figure 8-1. Typical Application

Figure 8-1 shows an LMK03000 family device used in a typical application. In this setup the clock may be multiplied, reconditioned, and redistributed. Both the OSCin/OSCin* and CLKoutX/CLKoutX* pins can be used in a single-ended or a differential fashion, which is discussed later in this datasheet. The GOE pin needs to be high for the outputs to operate. One technique sometimes used is to take the output of the LD (Lock Detect) pin and use this as an input to the GOE pin. If this is done, then the outputs will turn off if lock detect circuit detects that the PLL is out of lock. The loop filter actually consists of seven components, but four of these components that for the third and fourth poles of the loop filter are integrated in the chip. The first and second pole of the loop filter are external.

8.2 BIAS PIN

See [Section 6.1](#) for bias pin information.

8.3 LDO BYPASS

See [Section 6.2](#) for LDO bypass information.

8.4 LOOP FILTER

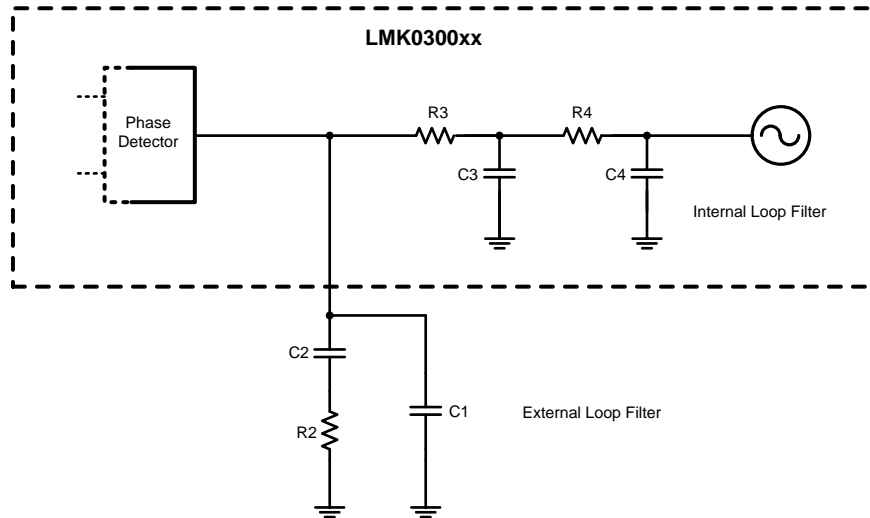

Figure 8-2. Loop Filter

The internal charge pump is directly connected to the integrated loop filter components. The first and second pole of the loop filter are externally attached as shown in Figure 8-2. When the loop filter is designed, it must be stable over the entire frequency band, meaning that the changes in $K_{V_{tune}}$ from the low to high band specification will not make the loop filter unstable. The design of the loop filter is application specific and can be rather involved, but is discussed in depth in the Clock Conditioner Owner's Manual provided by Texas Instruments. When designing with the integrated loop filter of the LMK03000 family, considerations for minimum resistor thermal noise often lead one to the decision to design for the minimum value for integrated resistors, R3 and R4. Both the integrated loop filter resistors and capacitors (C3 and C4) also restrict how wide the loop bandwidth the PLL can have. However, these integrated components do have the advantage that they are closer to the VCO and can therefore filter out some noise and spurs better than external components. For this reason, a common strategy is to minimize the internal loop filter resistors and then design for the largest internal capacitor values that permit a wide enough loop bandwidth. In some situations where spurs requirements are very stringent and there is margin on phase noise, it might make sense to design for a loop filter with integrated resistor values that are larger than their minimum value.

8.5 CURRENT CONSUMPTION / POWER DISSIPATION CALCULATIONS

Due to the myriad of possible configurations the following table serves to provide enough information to allow the user to calculate estimated current consumption of the device. Unless otherwise noted $V_{CC} = 3.3$ V, $T_A = 25$ °C.

Table 8-1. Block Current Consumption

Block	Condition	Current Consumption at 3.3 V (mA)	Power Dissipated in device (mW)	Power Dissipated in LVPECL emitter resistors (mW)
Entire device, core current	All outputs off; No LVPECL emitter resistors connected	86.0	283.8	-
Low clock buffer (internal)	The low clock buffer is enabled anytime one of CLKout0 through CLKout3 are enabled	9	29.7	-
High clock buffer (internal)	The high clock buffer is enabled anytime one of the CLKout4 through CLKout7 are enabled	9	29.7	-
Output buffers	Fout buffer, EN_Fout = 1	14.5	47.8	-
	LVDS output, Bypassed mode	17.8	58.7	-
	LVPECL output, Bypassed mode (includes 120 Ω emitter resistors)	40	72	60
	LVPECL output, disabled mode (includes 120 Ω emitter resistors)	17.4	38.3	19.1
	LVPECL output, disabled mode. No emitter resistors placed; open outputs	0	0	-
Divide circuitry per output	Divide enabled, divide = 2	5.3	17.5	-
	Divide enabled, divide > 2	8.5	28.0	-
Delay circuitry per output	Delay enabled, delay < 8	5.8	19.1	-
	Delay enabled, delay > 7	9.9	32.7	-
Entire device	CLKout0 & CLKout4 enabled in Bypassed mode	161.8	474	60

From [Table 8-1](#) the current consumption can be calculated in any configuration. For example, the current for the entire device with 1 LVDS (CLKout0) & 1 LVPECL (CLKout4) output in Bypassed mode can be calculated by adding up the following blocks: core current, low clock buffer, high clock buffer, one LVDS output buffer current, and one LVPECL output buffer current. There will also be one LVPECL output drawing emitter current, but some of the power from the current draw is dissipated in the external 120 Ω resistors which doesn't add to the power dissipation budget for the device. If delays or divides are switched in, then the additional current for these stages needs to be added as well.

For power dissipated by the device, the total current entering the device is multiplied by the voltage at the device minus the power dissipated in any emitter resistors connected to any of the LVPECL outputs. If no emitter resistors are connected to the LVPECL outputs, this power will be 0 watts. For example, in the case of 1 LVDS (CLKout0) & 1 LVPECL (CLKout4) operating at 3.3 volts, we calculate $3.3 \text{ V} \times (86 + 9 + 9 + 17.8 + 40) \text{ mA} = 3.3 \text{ V} \times 161.8 \text{ mA} = 533.9 \text{ mW}$. Because the LVPECL output (CLKout4) has the emitter resistors hooked up and the power dissipated by these resistors is 60 mW, the total device power dissipation is $533.9 \text{ mW} - 60 \text{ mW} = 473.9 \text{ mW}$.

When the LVPECL output is active, ~1.9 V is the average voltage on each output as calculated from the LVPECL V_{OH} & V_{OL} typical specification. Therefore the power dissipated in each emitter resistor is approximately $(1.9 \text{ V})^2 / 120 \text{ } \Omega = 30 \text{ mW}$. When the LVPECL output is disabled, the emitter resistor voltage is ~1.07 V. Therefore the power dissipated in each emitter resistor is approximately $(1.07 \text{ V})^2 / 120 \text{ } \Omega = 9.5 \text{ mW}$.

8.6 THERMAL MANAGEMENT

Power consumption of the LMK03000 family of devices can be high enough to require attention to thermal management. For reliability and performance reasons the die temperature should be limited to a maximum of 125 °C. That is, as an estimate, T_A (ambient temperature) plus device power consumption times θ_{JA} should not exceed 125 °C.

The package of the device has an exposed pad that provides the primary heat removal path as well as excellent electrical grounding to the printed circuit board. To maximize the removal of heat from the package a thermal land pattern including multiple vias to a ground plane must be incorporated on the PCB within the footprint of the package. The exposed pad must be soldered down to ensure adequate heat conduction out of the package. A recommended land and via pattern is shown in Figure 8-3. More information on soldering WQFN packages can be obtained at www.ti.com.

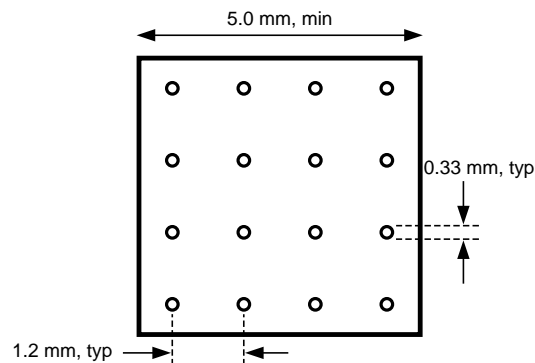

Figure 8-3. Recommended Land and Via Pattern

To minimize junction temperature it is recommended that a simple heat sink be built into the PCB (if the ground plane layer is not exposed). This is done by including a copper area of about 2 square inches on the opposite side of the PCB from the device. This copper area may be plated or solder coated to prevent corrosion but should not have conformal coating (if possible), which could provide thermal insulation. The vias shown in Figure 8-3 should connect these top and bottom copper layers and to the ground layer. These vias act as “heat pipes” to carry the thermal energy away from the device side of the board to where it can be more effectively dissipated.

8.7 TERMINATION AND USE OF CLOCK OUTPUTS (DRIVERS)

When terminating clock drivers keep in mind these guidelines for optimum phase noise and jitter performance:

- Transmission line theory should be followed for good impedance matching to prevent reflections.
- Clock drivers should be presented with the proper loads. For example:
 - LVDS drivers are current drivers and require a closed current loop.
 - LVPECL drivers are open emitter and require a DC path to ground.
- Receivers should be presented with a signal biased to their specified DC bias level (common mode voltage) for proper operation. Some receivers have self-biasing inputs that automatically bias to the proper voltage level. In this case, the signal should normally be AC coupled.

It is possible to drive a non-LVPECL or non-LVDS receiver with a LVDS or LVPECL driver as long as the above guidelines are followed. Check the datasheet of the receiver or input being driven to determine the best termination and coupling method to be sure that the receiver is biased at its optimum DC voltage (common mode voltage). For example, when driving the OSCin/OSCin* input of the LMK03000 family, OSCin/OSCin* should be AC coupled because OSCin/OSCin* biases the signal to the proper DC level, see [Figure 8-1](#). This is only slightly different from the AC coupled cases described in 3.7.2 because the DC blocking capacitors are placed between the termination and the OSCin/OSCin* pins, but the concept remains the same, which is the receiver (OSCin/OSCin*) set the input to the optimum DC bias voltage (common mode voltage), not the driver.

8.7.1 Termination for DC Coupled Differential Operation

For DC coupled operation of an LVDS driver, terminate with 100 Ω as close as possible to the LVDS receiver as shown in [Figure 8-4](#). To ensure proper LVDS operation when DC coupling it is recommend to use LVDS receivers without fail-safe or internal input bias such as DS90LV110T. The LVDS driver will provide the DC bias level for the LVDS receiver. For operation with LMK03000 family LVDS drivers it is recommend to use AC coupling with LVDS receivers that have an internal DC bias voltage. Some fail-safe circuitry will present a DC bias (common mode voltage) which will prevent the LVDS driver from working correctly. This precaution does not apply to the LVPECL drivers.

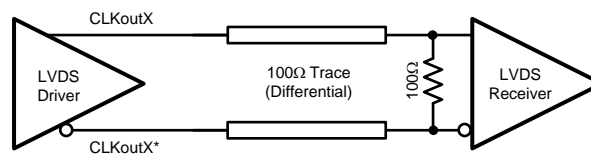

Figure 8-4. Differential LVDS Operation, DC Coupling

For DC coupled operation of an LVPECL driver, terminate with $50\ \Omega$ to $V_{CC} - 2\text{ V}$ as shown in Figure 8-5. Alternatively terminate with a Thevenin equivalent circuit ($120\ \Omega$ resistor connected to V_{CC} and an $82\ \Omega$ resistor connected to ground with the driver connected to the junction of the $120\ \Omega$ and $82\ \Omega$ resistors) as shown in Figure 8-6 for $V_{CC} = 3.3\text{ V}$.

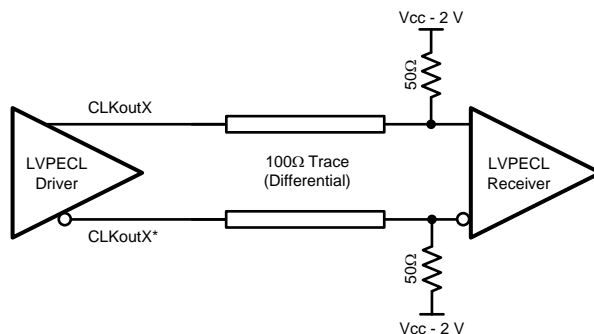

Figure 8-5. Differential LVPECL Operation, DC Coupling

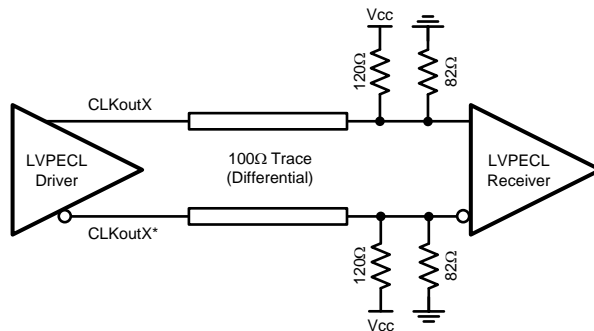

Figure 8-6. Differential LVPECL Operation, DC Coupling, Thevenin Equivalent

8.7.2 Termination for AC Coupled Differential Operation

AC coupling allows for shifting the DC bias level (common mode voltage) when driving different receiver standards. Since AC coupling prevents the driver from providing a DC bias voltage at the receiver it is important to ensure the receiver is biased to its ideal DC level.

When driving LVDS receivers with an LVDS driver, the signal may be AC coupled by adding DC blocking capacitors, however the proper DC bias point needs to be established at the receiver. If the receiver does not automatically bias its input, one way to do this is with the termination circuitry in Figure 8-7.

When using AC coupling with LVDS outputs, there may be a startup delay observed in the clock output due to capacitor charging. Figure 8-7 employs 0.1 μF capacitors. This value may need to be adjusted to meet the startup requirements for a particular application.

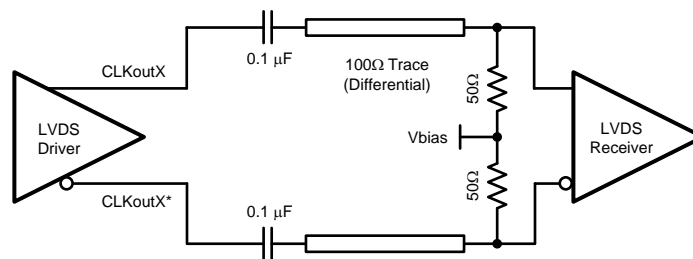

Figure 8-7. Differential LVDS Operation, AC Coupling

LVPECL drivers require a DC path to ground. When AC coupling an LVPECL signal use 120 Ω emitter resistors close to the LVPECL driver to provide a DC path to ground as shown in Figure 8-8. For proper receiver operation, the signal should be biased to the DC bias level (common mode voltage) specified by the receiver. The typical DC bias voltage (common mode voltage) for LVPECL receivers is 2 V. A Thevenin equivalent circuit (82 Ω resistor connected to Vcc and a 120 Ω resistor connected to ground with the driver connected to the junction of the 82 Ω and 120 Ω resistors) is a valid termination as shown in Figure 8-8 for Vcc = 3.3 V. Note this Thevenin circuit is different from the DC coupled example in Figure 8-6.

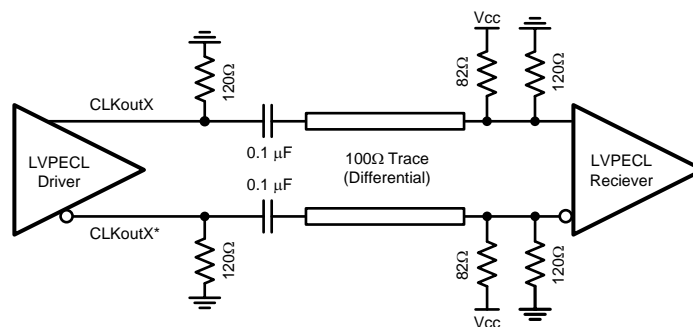

Figure 8-8. Differential LVPECL Operation, AC Coupling, Thevenin Equivalent

8.7.3 Termination for Single-Ended Operation

A balun can be used with either LVDS or LVPECL drivers to convert the balanced, differential signal into an unbalanced, single-ended signal.

It is possible to use an LVPECL driver as one or two separate 800 mV p-p signals. When DC coupling one of the LMK03000 family clock LVPECL drivers, the termination should still be 50 ohms to $V_{CC} - 2\text{ V}$ as shown in Figure 8-9. Again the Thevenin equivalent circuit (120 Ω resistor connected to V_{CC} and an 82 Ω resistor connected to ground with the driver connected to the junction of the 120 Ω and 82 Ω resistors) is a valid termination as shown in Figure 8-10 for $V_{CC} = 3.3\text{ V}$.

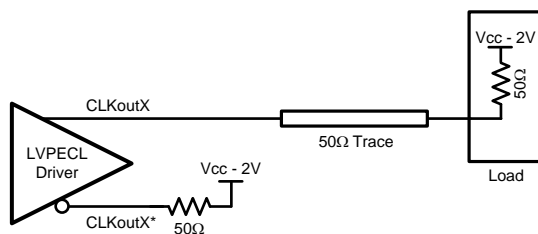

Figure 8-9. Single-Ended LVPECL Operation, DC Coupling

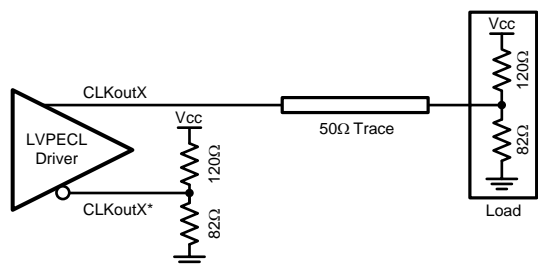

Figure 8-10. Single-Ended LVPECL Operation, DC Coupling, Thevenin Equivalent

When AC coupling an LVPECL driver use a 120 Ω emitter resistor to provide a DC path to ground and ensure a 50 ohm termination with the proper DC bias level for the receiver. The typical DC bias voltage for LVPECL receivers is 2 V (See Section 8.7.2). If the other driver is not used it should be terminated with either a proper AC or DC termination. This latter example of AC coupling a single-ended LVPECL signal can be used to measure single-ended LVPECL performance using a spectrum analyzer or phase noise analyzer. When using most RF test equipment no DC bias (0 V DC) is expected for safe and proper operation. The internal 50 ohm termination the test equipment provides correctly terminates the LVPECL driver being measured as shown Figure 8-11. When using only one LVPECL driver of a CLKoutX/CLKoutX* pair, be sure to properly terminate the unused driver.

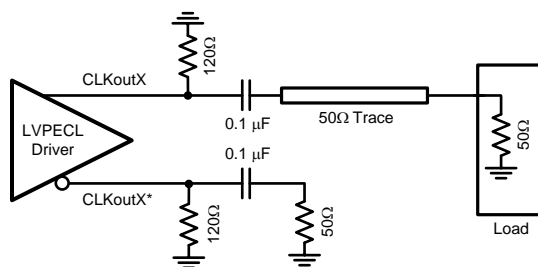

Figure 8-11. Single-Ended LVPECL Operation, AC Coupling

8.7.4 Conversion to LVCMOS Outputs

To drive an LVCMOS input with an LMK03000 family LVDS or LVPECL output, an LVPECL/LVDS to LVCMOS converter such as TI's DS90LV018A, DS90LV028A, DS90LV048A, etc. is required. For best noise performance, LVPECL provides a higher voltage swing into input of the converter.

8.8 OSCin INPUT

In addition to LVDS and LVPECL inputs, OSCin can also be driven with a sine wave. The OSCin input can be driven single-ended or differentially with sine waves. The configurations for these are shown in Figure 8-12 and Figure 8-13. Figure 8-14 shows the recommended power level for sine wave operation for both differential and single-ended sources over frequency. The part will operate at power levels below the recommended power level, but as power decreases the PLL noise performance will degrade. The VCO noise performance will remain constant. At the recommended power level the PLL phase noise degradation from full power operation (8 dBm) is less than 2 dB.

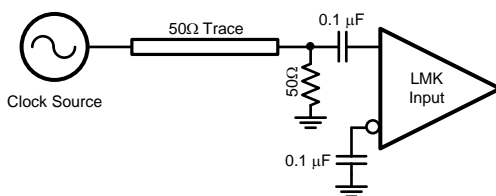

Figure 8-12. Single-Ended Sine Wave Input

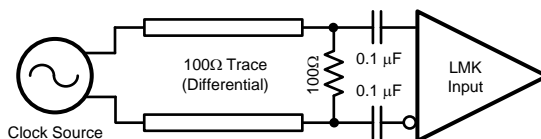

Figure 8-13. Differential Sine Wave Input

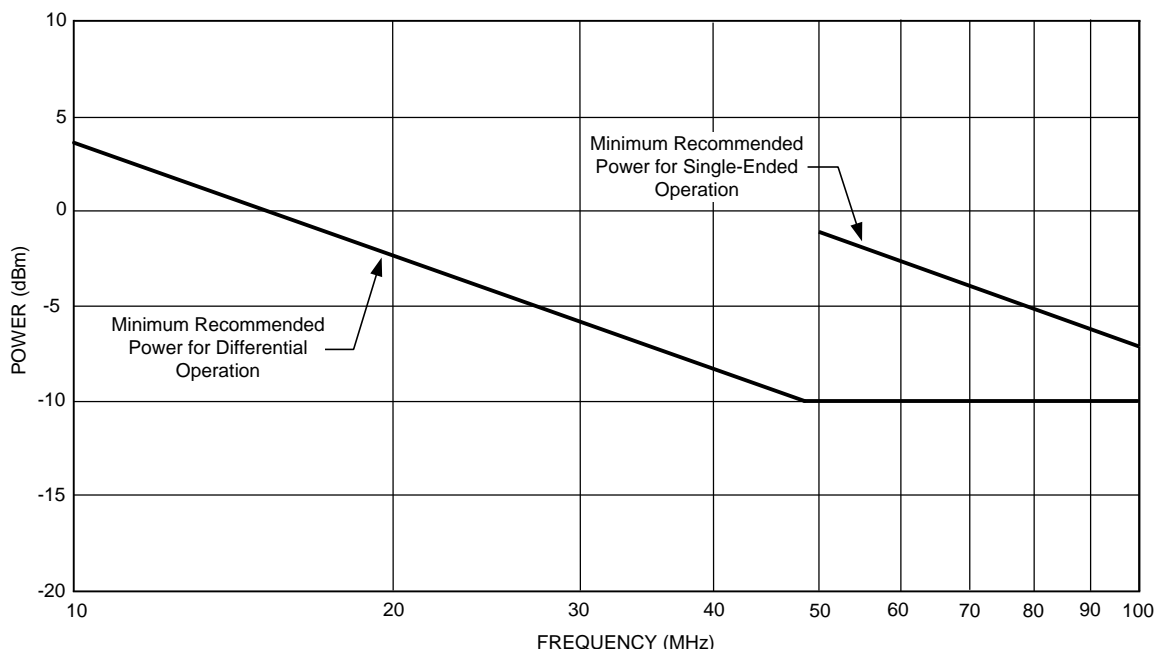

Figure 8-14. Recommended OSCin Power for Operation with a Sine Wave Input

8.9 MORE THAN EIGHT OUTPUTS WITH AN LMK03000 FAMILY DEVICE

The LMK03000 family devices include eight or less outputs. When more than 8 outputs are required the footprint compatible LMK01000 family may be used for clock distribution. By using an LMK03000 device with eight LMK01000 family devices up to 64 clocks may be distributed in many different LVDS / LVPECL combinations. It's possible to distribute more than 64 clocks by adding more LMK01000 family devices. Refer to AN-1864 (literature number [SNAA060](#)) for more details on how to do this.

Revision History

NOTE: Page numbers for previous revisions may differ from page numbers in the current version.

Changes from Revision N (March 2013) to Revision O	Page
<ul style="list-style-type: none">Changed layout of National Data Sheet to TI format	37

PACKAGING INFORMATION

Orderable Device	Status (1)	Package Type	Package Drawing	Pins	Package Qty	Eco Plan (2)	Lead/Ball Finish (6)	MSL Peak Temp (3)	Op Temp (°C)	Device Marking (4/5)	Samples
LMK03000CISQ/NOPB	ACTIVE	WQFN	RHS	48	250	Green (RoHS & no Sb/Br)	CU SN	Level-3-260C-168 HR	-40 to 85	K03000CI	Samples
LMK03000CISQX/NOPB	ACTIVE	WQFN	RHS	48	2500	Green (RoHS & no Sb/Br)	CU SN	Level-3-260C-168 HR	-40 to 85	K03000CI	Samples
LMK03000DISQ/NOPB	ACTIVE	WQFN	RHS	48	1000	Green (RoHS & no Sb/Br)	CU SN	Level-3-260C-168 HR	-40 to 85	K03000DI	Samples
LMK03000DISQE/NOPB	ACTIVE	WQFN	RHS	48	250	Green (RoHS & no Sb/Br)	CU SN	Level-3-260C-168 HR	-40 to 85	K03000DI	Samples
LMK03000DISQX/NOPB	ACTIVE	WQFN	RHS	48	2500	Green (RoHS & no Sb/Br)	CU SN	Level-3-260C-168 HR	-40 to 85	K03000DI	Samples
LMK03000ISQ/NOPB	ACTIVE	WQFN	RHS	48	250	Green (RoHS & no Sb/Br)	CU SN	Level-3-260C-168 HR	-40 to 85	K03000 I	Samples
LMK03001CISQ/NOPB	ACTIVE	WQFN	RHS	48	250	Green (RoHS & no Sb/Br)	CU SN	Level-3-260C-168 HR	-40 to 85	K03001CI	Samples
LMK03001CISQX/NOPB	ACTIVE	WQFN	RHS	48	2500	Green (RoHS & no Sb/Br)	CU SN	Level-3-260C-168 HR	-40 to 85	K03001CI	Samples
LMK03001DISQ/NOPB	ACTIVE	WQFN	RHS	48	1000	Green (RoHS & no Sb/Br)	CU SN	Level-3-260C-168 HR	-40 to 85	K03001DI	Samples
LMK03001DISQE/NOPB	ACTIVE	WQFN	RHS	48	250	Green (RoHS & no Sb/Br)	CU SN	Level-3-260C-168 HR	-40 to 85	K03001DI	Samples
LMK03001DISQX/NOPB	ACTIVE	WQFN	RHS	48	2500	Green (RoHS & no Sb/Br)	CU SN	Level-3-260C-168 HR	-40 to 85	K03001DI	Samples
LMK03001ISQ/NOPB	ACTIVE	WQFN	RHS	48	250	Green (RoHS & no Sb/Br)	CU SN	Level-3-260C-168 HR	-40 to 85	K03001 I	Samples
LMK03033CISQ/NOPB	ACTIVE	WQFN	RHS	48	1000	Green (RoHS & no Sb/Br)	CU SN	Level-3-260C-168 HR	-40 to 85	K03033CI	Samples
LMK03033CISQE/NOPB	ACTIVE	WQFN	RHS	48	250	Green (RoHS & no Sb/Br)	CU SN	Level-3-260C-168 HR	-40 to 85	K03033CI	Samples
LMK03033CISQX/NOPB	ACTIVE	WQFN	RHS	48	2500	Green (RoHS & no Sb/Br)	CU SN	Level-3-260C-168 HR	-40 to 85	K03033CI	Samples
LMK03033ISQ/NOPB	ACTIVE	WQFN	RHS	48	1000	Green (RoHS & no Sb/Br)	CU SN	Level-3-260C-168 HR	-40 to 85	K03033 I	Samples
LMK03033ISQE/NOPB	ACTIVE	WQFN	RHS	48	250	Green (RoHS & no Sb/Br)	CU SN	Level-3-260C-168 HR	-40 to 85	K03033 I	Samples

Orderable Device	Status (1)	Package Type	Package Drawing	Pins	Package Qty	Eco Plan (2)	Lead/Ball Finish (6)	MSL Peak Temp (3)	Op Temp (°C)	Device Marking (4/5)	Samples
LMK03033ISQX/NOPB	ACTIVE	WQFN	RHS	48	2500	Green (RoHS & no Sb/Br)	CU SN	Level-3-260C-168 HR	-40 to 85	K03033 I	Samples

(1) The marketing status values are defined as follows:

ACTIVE: Product device recommended for new designs.

LIFEBUY: TI has announced that the device will be discontinued, and a lifetime-buy period is in effect.

NRND: Not recommended for new designs. Device is in production to support existing customers, but TI does not recommend using this part in a new design.

PREVIEW: Device has been announced but is not in production. Samples may or may not be available.

OBSOLETE: TI has discontinued the production of the device.

(2) **RoHS:** TI defines "RoHS" to mean semiconductor products that are compliant with the current EU RoHS requirements for all 10 RoHS substances, including the requirement that RoHS substance do not exceed 0.1% by weight in homogeneous materials. Where designed to be soldered at high temperatures, "RoHS" products are suitable for use in specified lead-free processes. TI may reference these types of products as "Pb-Free".

RoHS Exempt: TI defines "RoHS Exempt" to mean products that contain lead but are compliant with EU RoHS pursuant to a specific EU RoHS exemption.

Green: TI defines "Green" to mean the content of Chlorine (Cl) and Bromine (Br) based flame retardants meet JS709B low halogen requirements of <=1000ppm threshold. Antimony trioxide based flame retardants must also meet the <=1000ppm threshold requirement.

(3) MSL, Peak Temp. - The Moisture Sensitivity Level rating according to the JEDEC industry standard classifications, and peak solder temperature.

(4) There may be additional marking, which relates to the logo, the lot trace code information, or the environmental category on the device.

(5) Multiple Device Markings will be inside parentheses. Only one Device Marking contained in parentheses and separated by a "~" will appear on a device. If a line is indented then it is a continuation of the previous line and the two combined represent the entire Device Marking for that device.

(6) Lead/Ball Finish - Orderable Devices may have multiple material finish options. Finish options are separated by a vertical ruled line. Lead/Ball Finish values may wrap to two lines if the finish value exceeds the maximum column width.

Important Information and Disclaimer:The information provided on this page represents TI's knowledge and belief as of the date that it is provided. TI bases its knowledge and belief on information provided by third parties, and makes no representation or warranty as to the accuracy of such information. Efforts are underway to better integrate information from third parties. TI has taken and continues to take reasonable steps to provide representative and accurate information but may not have conducted destructive testing or chemical analysis on incoming materials and chemicals. TI and TI suppliers consider certain information to be proprietary, and thus CAS numbers and other limited information may not be available for release.

In no event shall TI's liability arising out of such information exceed the total purchase price of the TI part(s) at issue in this document sold by TI to Customer on an annual basis.

TAPE AND REEL INFORMATION

QUADRANT ASSIGNMENTS FOR PIN 1 ORIENTATION IN TAPE

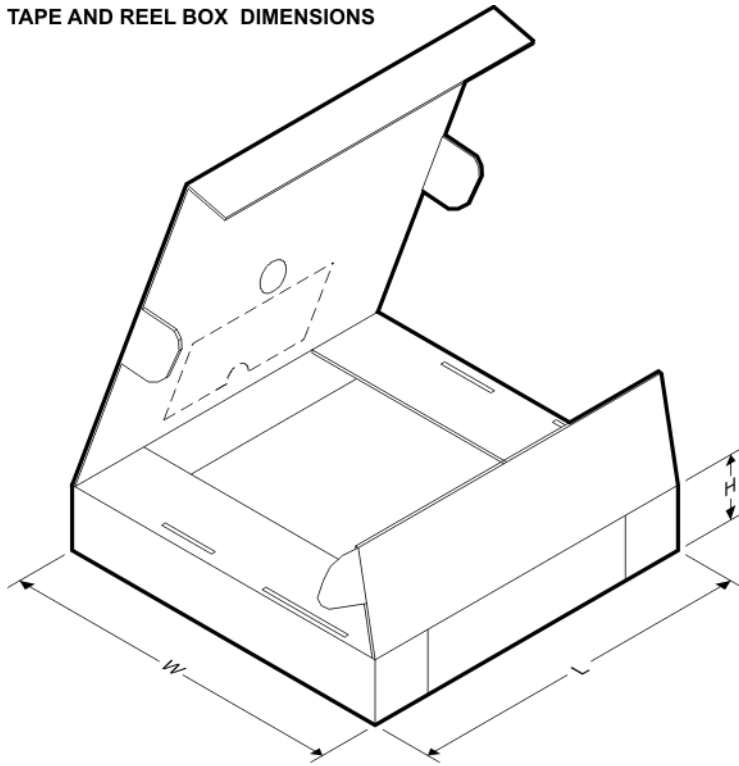

*All dimensions are nominal

Device	Package Type	Package Drawing	Pins	SPQ	Reel Diameter (mm)	Reel Width W1 (mm)	A0 (mm)	B0 (mm)	K0 (mm)	P1 (mm)	W (mm)	Pin1 Quadrant
LMK03000CISQ/NOPB	WQFN	RHS	48	250	178.0	16.4	7.3	7.3	1.3	12.0	16.0	Q1
LMK03000CISQX/NOPB	WQFN	RHS	48	2500	330.0	16.4	7.3	7.3	1.3	12.0	16.0	Q1
LMK03000DISQ/NOPB	WQFN	RHS	48	1000	330.0	16.4	7.3	7.3	1.3	12.0	16.0	Q1
LMK03000DISQE/NOPB	WQFN	RHS	48	250	178.0	16.4	7.3	7.3	1.3	12.0	16.0	Q1
LMK03000DISQX/NOPB	WQFN	RHS	48	2500	330.0	16.4	7.3	7.3	1.3	12.0	16.0	Q1
LMK03000ISQ/NOPB	WQFN	RHS	48	250	178.0	16.4	7.3	7.3	1.3	12.0	16.0	Q1
LMK03001CISQ/NOPB	WQFN	RHS	48	250	178.0	16.4	7.3	7.3	1.3	12.0	16.0	Q1
LMK03001CISQX/NOPB	WQFN	RHS	48	2500	330.0	16.4	7.3	7.3	1.3	12.0	16.0	Q1
LMK03001DISQ/NOPB	WQFN	RHS	48	1000	330.0	16.4	7.3	7.3	1.3	12.0	16.0	Q1
LMK03001DISQE/NOPB	WQFN	RHS	48	250	178.0	16.4	7.3	7.3	1.3	12.0	16.0	Q1
LMK03001DISQX/NOPB	WQFN	RHS	48	2500	330.0	16.4	7.3	7.3	1.3	12.0	16.0	Q1
LMK03001ISQ/NOPB	WQFN	RHS	48	250	178.0	16.4	7.3	7.3	1.3	12.0	16.0	Q1
LMK03033CISQ/NOPB	WQFN	RHS	48	1000	330.0	16.4	7.3	7.3	1.3	12.0	16.0	Q1
LMK03033CISQE/NOPB	WQFN	RHS	48	250	178.0	16.4	7.3	7.3	1.3	12.0	16.0	Q1
LMK03033CISQX/NOPB	WQFN	RHS	48	2500	330.0	16.4	7.3	7.3	1.3	12.0	16.0	Q1
LMK03033ISQ/NOPB	WQFN	RHS	48	1000	330.0	16.4	7.3	7.3	1.3	12.0	16.0	Q1
LMK03033ISQE/NOPB	WQFN	RHS	48	250	178.0	16.4	7.3	7.3	1.3	12.0	16.0	Q1
LMK03033ISQX/NOPB	WQFN	RHS	48	2500	330.0	16.4	7.3	7.3	1.3	12.0	16.0	Q1

TAPE AND REEL BOX DIMENSIONS

*All dimensions are nominal

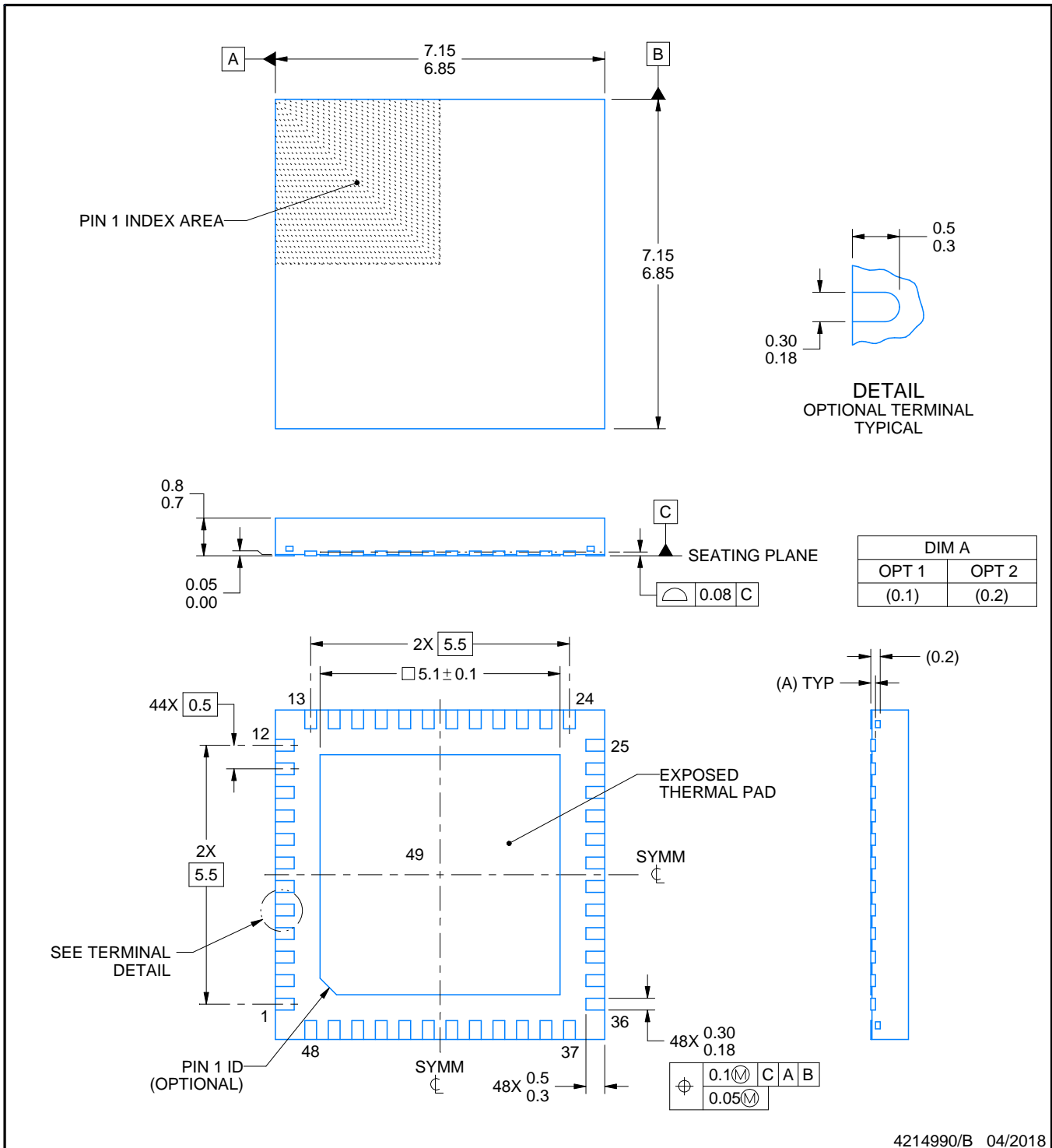
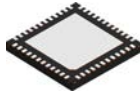
Device	Package Type	Package Drawing	Pins	SPQ	Length (mm)	Width (mm)	Height (mm)
LMK03000CISQ/NOPB	WQFN	RHS	48	250	210.0	185.0	35.0
LMK03000CISQX/NOPB	WQFN	RHS	48	2500	367.0	367.0	38.0
LMK03000DISQ/NOPB	WQFN	RHS	48	1000	367.0	367.0	38.0
LMK03000DISQE/NOPB	WQFN	RHS	48	250	210.0	185.0	35.0
LMK03000DISQX/NOPB	WQFN	RHS	48	2500	367.0	367.0	38.0
LMK03000ISQ/NOPB	WQFN	RHS	48	250	210.0	185.0	35.0
LMK03001CISQ/NOPB	WQFN	RHS	48	250	210.0	185.0	35.0
LMK03001CISQX/NOPB	WQFN	RHS	48	2500	367.0	367.0	38.0
LMK03001DISQ/NOPB	WQFN	RHS	48	1000	367.0	367.0	38.0
LMK03001DISQE/NOPB	WQFN	RHS	48	250	210.0	185.0	35.0
LMK03001DISQX/NOPB	WQFN	RHS	48	2500	367.0	367.0	38.0
LMK03001ISQ/NOPB	WQFN	RHS	48	250	210.0	185.0	35.0
LMK03033CISQ/NOPB	WQFN	RHS	48	1000	367.0	367.0	38.0
LMK03033CISQE/NOPB	WQFN	RHS	48	250	210.0	185.0	35.0
LMK03033CISQX/NOPB	WQFN	RHS	48	2500	367.0	367.0	38.0
LMK03033ISQ/NOPB	WQFN	RHS	48	1000	367.0	367.0	38.0
LMK03033ISQE/NOPB	WQFN	RHS	48	250	210.0	185.0	35.0
LMK03033ISQX/NOPB	WQFN	RHS	48	2500	367.0	367.0	38.0



4214990/B 04/2018

NOTES:

1. All linear dimensions are in millimeters. Any dimensions in parenthesis are for reference only. Dimensioning and tolerancing per ASME Y14.5M.
2. This drawing is subject to change without notice.
3. The package thermal pad must be soldered to the printed circuit board for thermal and mechanical performance.

EXAMPLE BOARD LAYOUT

RHS0048A

WQFN - 0.8 mm max height

PLASTIC QUAD FLATPACK - NO LEAD

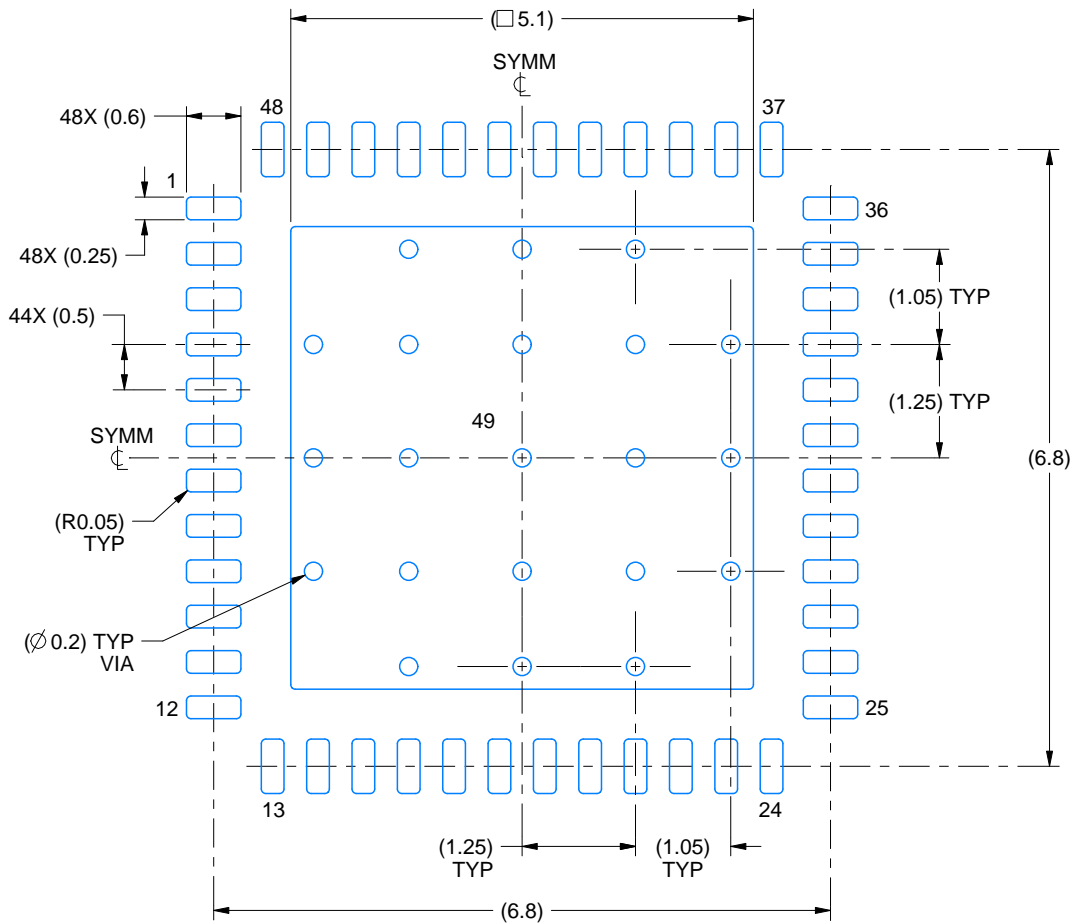

LAND PATTERN EXAMPLE
EXPOSED METAL SHOWN
SCALE:12X

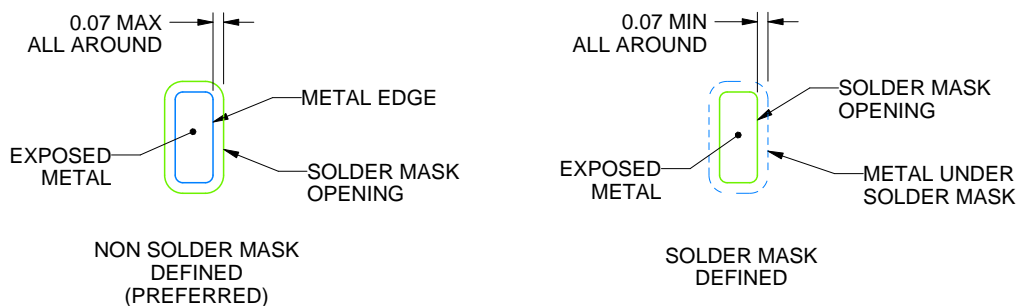

SOLDER MASK DETAILS

4214990/B 04/2018

NOTES: (continued)

4. This package is designed to be soldered to a thermal pad on the board. For more information, see Texas Instruments literature number SLUA271 (www.ti.com/lit/slua271).
5. Vias are optional depending on application, refer to device data sheet. If any vias are implemented, refer to their locations shown on this view. It is recommended that vias under paste be filled, plugged or tented.

EXAMPLE STENCIL DESIGN

RHS0048A

WQFN - 0.8 mm max height

PLASTIC QUAD FLATPACK - NO LEAD

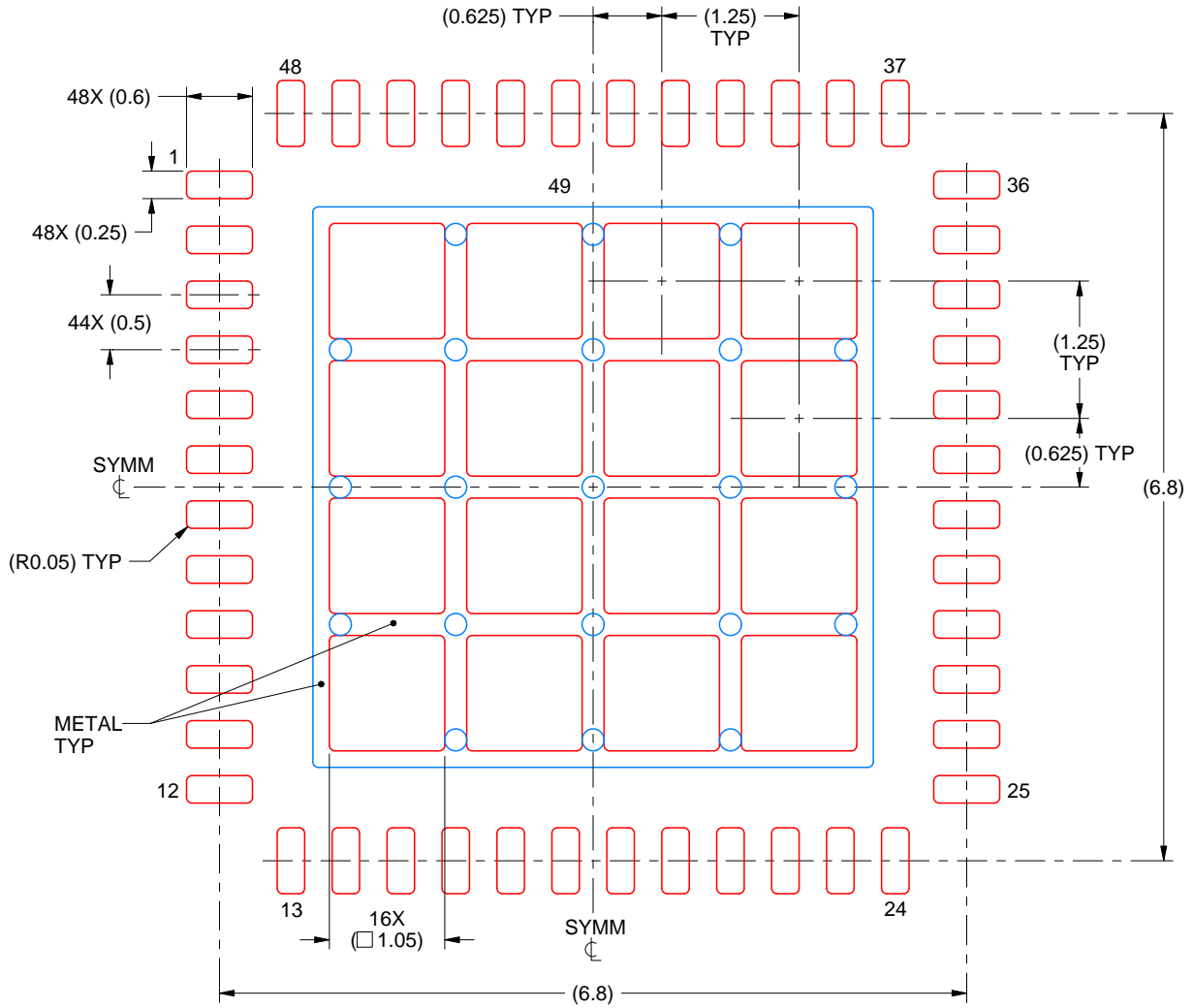

SOLDER PASTE EXAMPLE
 BASED ON 0.125 mm THICK STENCIL

EXPOSED PAD 49
 68% PRINTED SOLDER COVERAGE BY AREA UNDER PACKAGE
 SCALE:15X

4214990/B 04/2018

NOTES: (continued)

6. Laser cutting apertures with trapezoidal walls and rounded corners may offer better paste release. IPC-7525 may have alternate design recommendations.

IMPORTANT NOTICE AND DISCLAIMER

TI PROVIDES TECHNICAL AND RELIABILITY DATA (INCLUDING DATASHEETS), DESIGN RESOURCES (INCLUDING REFERENCE DESIGNS), APPLICATION OR OTHER DESIGN ADVICE, WEB TOOLS, SAFETY INFORMATION, AND OTHER RESOURCES "AS IS" AND WITH ALL FAULTS, AND DISCLAIMS ALL WARRANTIES, EXPRESS AND IMPLIED, INCLUDING WITHOUT LIMITATION ANY IMPLIED WARRANTIES OF MERCHANTABILITY, FITNESS FOR A PARTICULAR PURPOSE OR NON-INFRINGEMENT OF THIRD PARTY INTELLECTUAL PROPERTY RIGHTS.

These resources are intended for skilled developers designing with TI products. You are solely responsible for (1) selecting the appropriate TI products for your application, (2) designing, validating and testing your application, and (3) ensuring your application meets applicable standards, and any other safety, security, or other requirements. These resources are subject to change without notice. TI grants you permission to use these resources only for development of an application that uses the TI products described in the resource. Other reproduction and display of these resources is prohibited. No license is granted to any other TI intellectual property right or to any third party intellectual property right. TI disclaims responsibility for, and you will fully indemnify TI and its representatives against, any claims, damages, costs, losses, and liabilities arising out of your use of these resources.

TI's products are provided subject to TI's Terms of Sale (www.ti.com/legal/termsofsale.html) or other applicable terms available either on ti.com or provided in conjunction with such TI products. TI's provision of these resources does not expand or otherwise alter TI's applicable warranties or warranty disclaimers for TI products.

Mailing Address: Texas Instruments, Post Office Box 655303, Dallas, Texas 75265
Copyright © 2018, Texas Instruments Incorporated

Looking for pricing, stock, or lifecycle information?

Click below to explore more details on WIN SOURCE:

 [View LMK03001CISQ/NOPB on WIN SOURCE](#)

 [Texas Instruments](#) Information

Optimize Your Supply Chain with WIN SOURCE Solutions

-  Global Sourcing Solution
-  Obsolete Management
-  Cost Control Management
-  Shortage Management
-  Alternative Solution
-  Excess Inventory Management