



THE DATASHEET OF LMK02000ISQ/NOPB



Precision Clock Conditioner with Integrated PLL

Check for Samples: [LMK02000](#)

All trademarks are the property of their respective owners.

1 Features

- 20 fs Additive Jitter
- Integrated Integer-N PLL with Outstanding Normalized Phase Noise Contribution of -224 dBc/Hz
- Clock Output Frequency Range of 1 to 800 MHz
- 3 LVDS and 5 LVPECL Clock Outputs
- Dedicated Divider and Delay Blocks on Each Clock Output
- Pin Compatible Family of Clocking Devices
- 3.15 to 3.45 V Operation
- Package: 48 Pin WQFN (7.0 x 7.0 x 0.8 mm)

2 Target Applications

- Data Converter Clocking
- Networking, SONET/SDH, DSLAM
- Wireless Infrastructure
- Medical
- Test and Measurement
- Military / Aerospace

3 Description

The LMK02000 precision clock conditioner combines the functions of jitter cleaning/reconditioning, multiplication, and distribution of a reference clock. The device integrates a high performance Integer-N Phase Locked Loop (PLL), three LVDS, and five LVPECL clock output distribution blocks.

Each clock distribution block includes a programmable divider, a phase synchronization circuit, a programmable delay, a clock output mux, and an LVDS or LVPECL output buffer. This allows multiple integer-related and phase-adjusted copies of the reference to be distributed to eight system components.

The clock conditioner comes in a 48-pin WQFN package and is footprint compatible with other clocking devices in the same family.



3.1 Functional Block Diagram

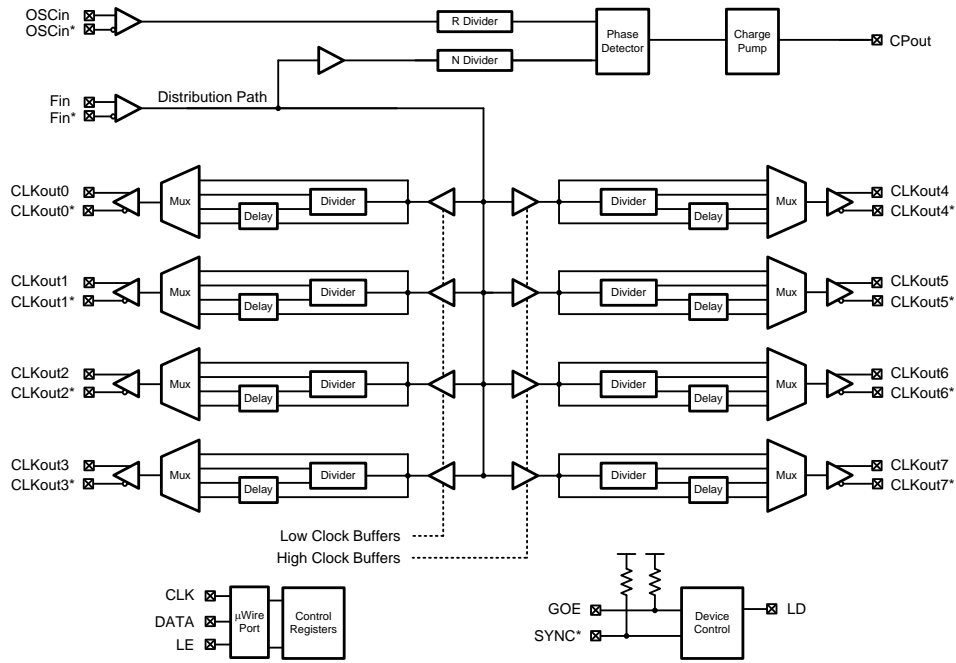

3.2 Connection Diagram

Figure 1. 48-Pin WQFN Package

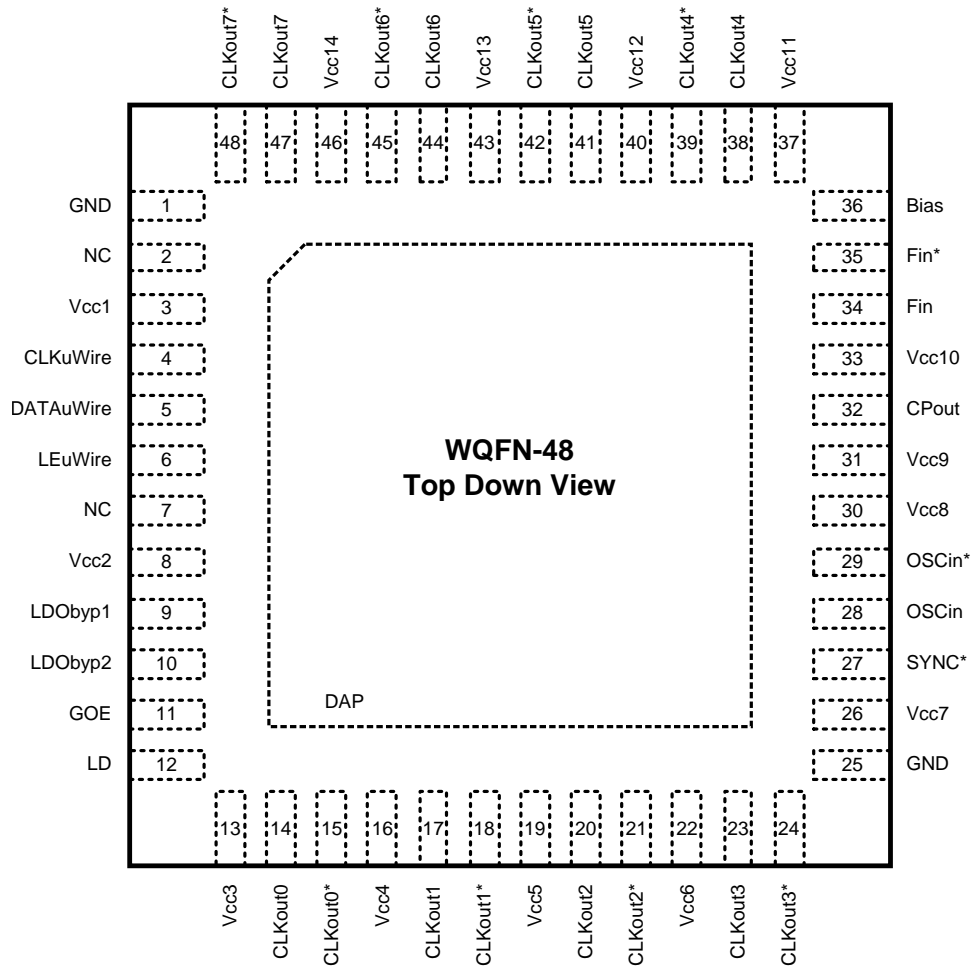

Pin Descriptions

Pin #	Pin Name	I/O	Description
1, 25	GND	-	Ground
2, 7	NC	-	No Connection to these pins
3, 8, 13, 16, 19, 22, 26, 30, 31, 33, 37, 40, 43, 46	Vcc1, Vcc2, Vcc3, Vcc4, Vcc5, Vcc6, Vcc7, Vcc8, Vcc9, Vcc10, Vcc11, Vcc12, Vcc13, Vcc14	-	Power Supply
4	CLKuWire	I	MICROWIRE Clock Input
5	DATAuWire	I	MICROWIRE Data Input
6	LEuWire	I	MICROWIRE Latch Enable Input
9, 10	LDObyp1, LDObyp2	-	LDO Bypass
11	GOE	I	Global Output Enable
12	LD	O	Lock Detect and Test Output
14, 15	CLKout0, CLKout0*	O	LVDS Clock Output 0
17, 18	CLKout1, CLKout1*	O	LVDS Clock Output 1
20, 21	CLKout2, CLKout2*	O	LVDS Clock Output 2
23, 24	CLKout3, CLKout3*	O	LVPECL Clock Output 3
27	SYNC*	I	Global Clock Output Synchronization
28, 29	OSCin, OSCin*	I	Oscillator Clock Input; Must be AC coupled

Connection Diagram (continued)

Pin Descriptions (continued)

Pin #	Pin Name	I/O	Description
32	CPout	O	Charge Pump Output
34, 35	Fin, Fin*	I	Frequency Input; Must be AC coupled
36	Bias	I	Bias Bypass
38, 39	CLKout4, CLKout4*	O	LVPECL Clock Output 4
41, 42	CLKout5, CLKout5*	O	LVPECL Clock Output 5
44, 45	CLKout6, CLKout6*	O	LVPECL Clock Output 6
47, 48	CLKout7, CLKout7*	O	LVPECL Clock Output 7
DAP	DAP	-	Die Attach Pad is Ground



These devices have limited built-in ESD protection. The leads should be shorted together or the device placed in conductive foam during storage or handling to prevent electrostatic damage to the MOS gates.

4 Absolute Maximum Ratings ⁽¹⁾⁽²⁾⁽³⁾

Parameter	Symbol	Ratings	Units
Power Supply Voltage	V_{CC}	-0.3 to 3.6	V
Input Voltage	V_{IN}	-0.3 to ($V_{CC} + 0.3$)	V
Storage Temperature Range	T_{STG}	-65 to 150	°C
Lead Temperature (solder 4 s)	T_L	+260	°C
Junction Temperature	T_J	125	°C

- "Absolute Maximum Ratings" indicate limits beyond which damage to the device may occur, including inoperability and degradation of device reliability and/or performance. Functional operation of the device and/or non-degradation at the Absolute Maximum Ratings or other conditions beyond those indicated in the Recommended Operating Conditions is not implied. The Recommended Operating Conditions indicate conditions at which the device is functional and the device should not be operated beyond such conditions.
- This device is a high performance integrated circuit with ESD handling precautions. Handling of this device should only be done at ESD protected work stations. The device is rated to a HBM-ESD of > 2 kV, a MM-ESD of > 200 V, and a CDM-ESD of > 1.2 kV.
- If Military/Aerospace specified devices are required, please contact the Texas Instruments Sales Office/ Distributors for availability and specifications.

5 Recommended Operating Conditions

Parameter	Symbol	Min	Typ	Max	Units
Ambient Temperature	T_A	-40	25	85	°C
Power Supply Voltage	V_{CC}	3.15	3.3	3.45	V

6 Package Thermal Resistance

Package	θ_{JA}	θ_{J-PAD} (Thermal Pad)
48-Lead WQFN ⁽¹⁾	27.4° C/W	5.8° C/W

- Specification assumes 16 thermal vias connect the die attach pad to the embedded copper plane on the 4-layer JEDEC board. These vias play a key role in improving the thermal performance of the WQFN. It is recommended that the maximum number of vias be used in the board layout.

7 Electrical Characteristics ⁽¹⁾

(3.15 V ≤ V_{CC} ≤ 3.45 V, -40 °C ≤ T_A ≤ 85 °C, Differential Inputs/Outputs; except as specified. Typical values represent most likely parametric norms at V_{CC} = 3.3 V, T_A = 25 °C, and at the Recommended Operation Conditions at the time of product characterization and are not specified).

Symbol	Parameter	Conditions	Min	Typ	Max	Units
Current Consumption						
I _{CC}	Power Supply Current ⁽²⁾	Entire device; CLKout0 & CLKout4 enabled in Bypass Mode		145.8		mA
		Entire device; All Outputs Off (no emitter resistors placed)		70		
I _{CCPD}	Power Down Current	POWERDOWN = 1		1		mA
Reference Oscillator						
f _{OSCin square}	Reference Oscillator Input Frequency Range for Square Wave	AC coupled; Differential (V _{OD})	1		200	MHz
V _{OSCinsquare}	Square Wave Input Voltage for OSCin and OSCin*		0.2		1.6	V _{pp}
Frequency Input						
f _{Fin}	Frequency Input Frequency Range		1		800	MHz
SLEW _{Fin}	Frequency Input Slew Rate		⁽³⁾⁽⁴⁾ 0.5			V/ns
DUTY _{Fin}	Frequency Input Duty Cycle		40		60	%
P _{Fin}	Input Power Range for Fin or Fin*	AC coupled	-13		8	dBm
PLL						
f _{COMP}	Phase Detector Frequency				40	MHz
I _{SOURCEPout}	Charge Pump Source Current	V _{CPout} = V _{CC} /2, PLL_CP_GAIN = 1x		100		μA
		V _{CPout} = V _{CC} /2, PLL_CP_GAIN = 4x		400		
		V _{CPout} = V _{CC} /2, PLL_CP_GAIN = 16x		1600		
		V _{CPout} = V _{CC} /2, PLL_CP_GAIN = 32x		3200		
I _{SINKCPout}	Charge Pump Sink Current	V _{CPout} = V _{CC} /2, PLL_CP_GAIN = 1x		-100		μA
		V _{CPout} = V _{CC} /2, PLL_CP_GAIN = 4x		-400		
		V _{CPout} = V _{CC} /2, PLL_CP_GAIN = 16x		-1600		
		V _{CPout} = V _{CC} /2, PLL_CP_GAIN = 32x		-3200		
I _{CPoutTRI}	Charge Pump TRI-STATE Current	0.5 V < V _{CPout} < V _{CC} - 0.5 V		2	10	nA
I _{CPout%MIS}	Magnitude of Charge Pump Sink vs. Source Current Mismatch	V _{CPout} = V _{CC} / 2 T _A = 25°C		3		%
I _{CPoutVTUNE}	Magnitude of Charge Pump Current vs. Charge Pump Voltage Variation	0.5 V < V _{CPout} < V _{CC} - 0.5 V T _A = 25°C		4		%
I _{CPoutTEMP}	Magnitude of Charge Pump Current vs. Temperature Variation			4		%
PN10kHz	PLL 1/f Noise at 10 kHz Offset ⁽⁵⁾ Normalized to 1 GHz Output Frequency	PLL_CP_GAIN = 1x		-117		dBc/Hz
		PLL_CP_GAIN = 32x		-122		

- (1) The Electrical Characteristics tables list ensured specifications under the listed Recommended Operating Conditions except as otherwise modified or specified by the Electrical Characteristics Conditions and/or Notes. Typical specifications are estimations only and are not ensured.
- (2) See [CURRENT CONSUMPTION / POWER DISSIPATION CALCULATIONS](#) for more current consumption / power dissipation calculation information.
- (3) For all frequencies the slew rate, SLEW_{Fin}, is measured between 20% and 80%.
- (4) Specification is ensured by characterization and is not tested in production.
- (5) A specification in modeling PLL in-band phase noise is the 1/f flicker noise, L_{PLL_flicker}(f), which is dominant close to the carrier. Flicker noise has a 10 dB/decade slope. PN10kHz is normalized to a 10 kHz offset and a 1 GHz carrier frequency. PN10kHz = L_{PLL_flicker}(10 kHz) - 20log(Fout / 1 GHz), where L_{PLL_flicker}(f) is the single side band phase noise of only the flicker noise's contribution to total noise, L(f). To measure L_{PLL_flicker}(f) it is important to be on the 10 dB/decade slope close to the carrier. A high phase detector frequency and a clean crystal are important to isolating this noise source from the total phase noise, L(f). L_{PLL_flicker}(f) can be masked by the reference oscillator performance if a low power or noisy source is used. The total PLL inband phase noise performance is the sum of L_{PLL_flicker}(f) and L_{PLL_flat}(f).

Electrical Characteristics ⁽¹⁾ (continued)

(3.15 V ≤ V_{CC} ≤ 3.45 V, -40 °C ≤ T_A ≤ 85 °C, Differential Inputs/Outputs; except as specified. Typical values represent most likely parametric norms at V_{CC} = 3.3 V, T_A = 25 °C, and at the Recommended Operation Conditions at the time of product characterization and are not specified).

Symbol	Parameter	Conditions	Min	Typ	Max	Units
PN1Hz	Normalized Phase Noise Contribution ⁽⁶⁾	PLL_CP_GAIN = 1x		-219		dBc/Hz
		PLL_CP_GAIN = 32x		-224		
Clock Distribution Section ⁽⁷⁾ - LVDS Clock Outputs (CLKout0 to CLKout2)						
Jitter _{ADD}	Additive RMS Jitter ⁽⁷⁾	R _L = 100 Ω Distribution Path = 800 MHz Bandwidth = 12 kHz to 20 MHz	CLKoutX_MUX = Bypass		20	fs
			CLKoutX_MUX = Divided CLKoutX_DIV = 4		75	
t _{SKEW}	CLKoutX to CLKoutY ⁽⁴⁾	Equal loading and identical clock configuration R _L = 100 Ω	-30	±4	30	ps
V _{OD}	Differential Output Voltage	R _L = 100 Ω	250	350	450	mV
ΔV _{OD}	Change in magnitude of V _{OD} for complementary output states	R _L = 100 Ω	-50		50	mV
V _{OS}	Output Offset Voltage	R _L = 100 Ω	1.070	1.25	1.370	V
ΔV _{OS}	Change in magnitude of V _{OS} for complementary output states	R _L = 100 Ω	-35		35	mV
I _{SA} I _{SB}	Clock Output Short Circuit Current single ended	Single ended outputs shorted to GND	-24		24	mA
I _{SAB}	Clock Output Short Circuit Current differential	Complementary outputs tied together	-12		12	mA
Clock Distribution Section ⁽⁷⁾ - LVPECL Clock Outputs (CLKout3 to CLKout7)						
Jitter _{ADD}	Additive RMS Jitter ⁽⁷⁾	R _L = 100 Ω Distribution Path = 800 MHz Bandwidth = 12 kHz to 20 MHz	CLKoutX_MUX = Bypass		20	fs
			CLKoutX_MUX = Divided CLKoutX_DIV = 4		75	
t _{SKEW}	CLKoutX to CLKoutY ⁽⁴⁾	Equal loading and identical clock configuration Termination = 50 Ω to V _{CC} - 2 V	-30	±3	30	ps
V _{OH}	Output High Voltage	Termination = 50 Ω to V _{CC} - 2 V		V _{CC} - 0.98		V
V _{OL}	Output Low Voltage			V _{CC} - 1.8		V
V _{OD}	Differential Output Voltage		660	810	965	mV
Digital LVTTTL Interfaces ⁽⁸⁾						
V _{IH}	High-Level Input Voltage		2.0		V _{CC}	V
V _{IL}	Low-Level Input Voltage				0.8	V
I _{IH}	High-Level Input Current	V _{IH} = V _{CC}	-5.0		5.0	μA
I _{IL}	Low-Level Input Current	V _{IL} = 0	-40.0		5.0	μA
V _{OH}	High-Level Output Voltage	I _{OH} = +500 μA	V _{CC} - 0.4			V

(6) A specification in modeling PLL in-band phase noise is the Normalized Phase Noise Contribution, L_{PLL_flat}(f), of the PLL and is defined as PN1Hz = L_{PLL_flat}(f) - 20log(N) - 10log(f_{COMP}). L_{PLL_flat}(f) is the single side band phase noise measured at an offset frequency, f, in a 1 Hz Bandwidth and f_{COMP} is the phase detector frequency of the synthesizer. L_{PLL_flat}(f) contributes to the total noise, L(f). To measure L_{PLL_flat}(f) the offset frequency, f, must be chosen sufficiently smaller than the loop bandwidth of the PLL, and yet large enough to avoid a substantial noise contribution from the reference and flicker noise. L_{PLL_flat}(f) can be masked by the reference oscillator performance if a low power or noisy source is used.

(7) The Clock Distribution Section includes all parts of the device except the PLL section. Typical Additive Jitter specifications apply to the clock distribution section only.

(8) Applies to GOE, LD, and SYNC*.

Electrical Characteristics ⁽¹⁾ (continued)

(3.15 V ≤ V_{CC} ≤ 3.45 V, -40 °C ≤ T_A ≤ 85 °C, Differential Inputs/Outputs; except as specified. Typical values represent most likely parametric norms at V_{CC} = 3.3 V, T_A = 25 °C, and at the Recommended Operation Conditions at the time of product characterization and are not specified).

Symbol	Parameter	Conditions	Min	Typ	Max	Units
V _{OL}	Low-Level Output Voltage	I _{OL} = -500 μA			0.4	V
Digital MICROWIRE Interfaces ⁽⁹⁾						
V _{IH}	High-Level Input Voltage		1.6		V _{CC}	V
V _{IL}	Low-Level Input Voltage				0.4	V
I _{IH}	High-Level Input Current	V _{IH} = V _{CC}	-5.0		5.0	μA
I _{IL}	Low-Level Input Current	V _{IL} = 0	-5.0		5.0	μA
MICROWIRE Timing						
t _{CS}	Data to Clock Set Up Time	See Data Input Timing	25			ns
t _{CH}	Data to Clock Hold Time	See Data Input Timing	8			ns
t _{CWH}	Clock Pulse Width High	See Data Input Timing	25			ns
t _{CWL}	Clock Pulse Width Low	See Data Input Timing	25			ns
t _{ES}	Clock to Enable Set Up Time	See Data Input Timing	25			ns
t _{CES}	Enable to Clock Set Up Time	See Data Input Timing	25			ns
t _{EWL}	Enable Pulse Width High	See Data Input Timing	25			ns

(9) Applies to CLKuWire, DATAuWire, and LEuWire.

8 Serial Data Timing Diagram

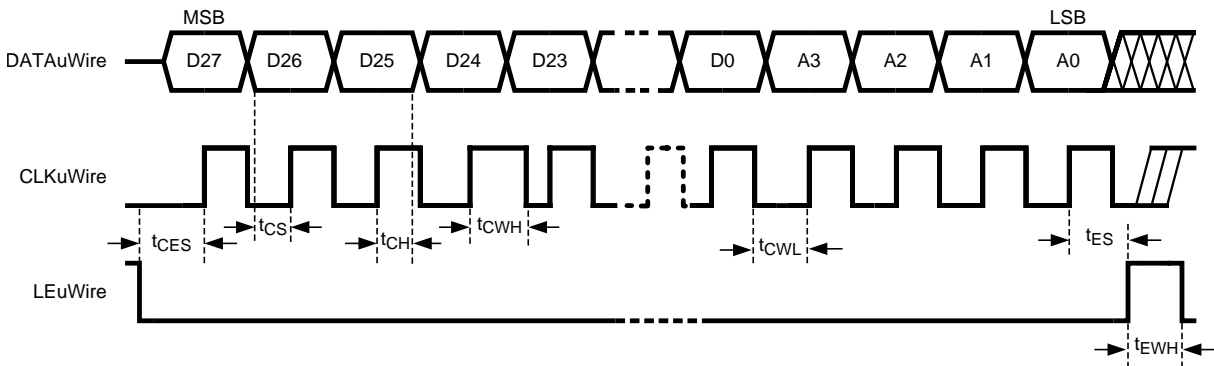

Data bits set on the DATAuWire signal are clocked into a shift register, MSB first, on each rising edge of the CLKuWire signal. On the rising edge of the LEuWire signal, the data is sent from the shift register to the addressed register determined by the LSB bits. After the programming is complete the CLKuWire, DATAuWire, and LEuWire signals should be returned to a low state.

9 Charge Pump Current Specification Definitions

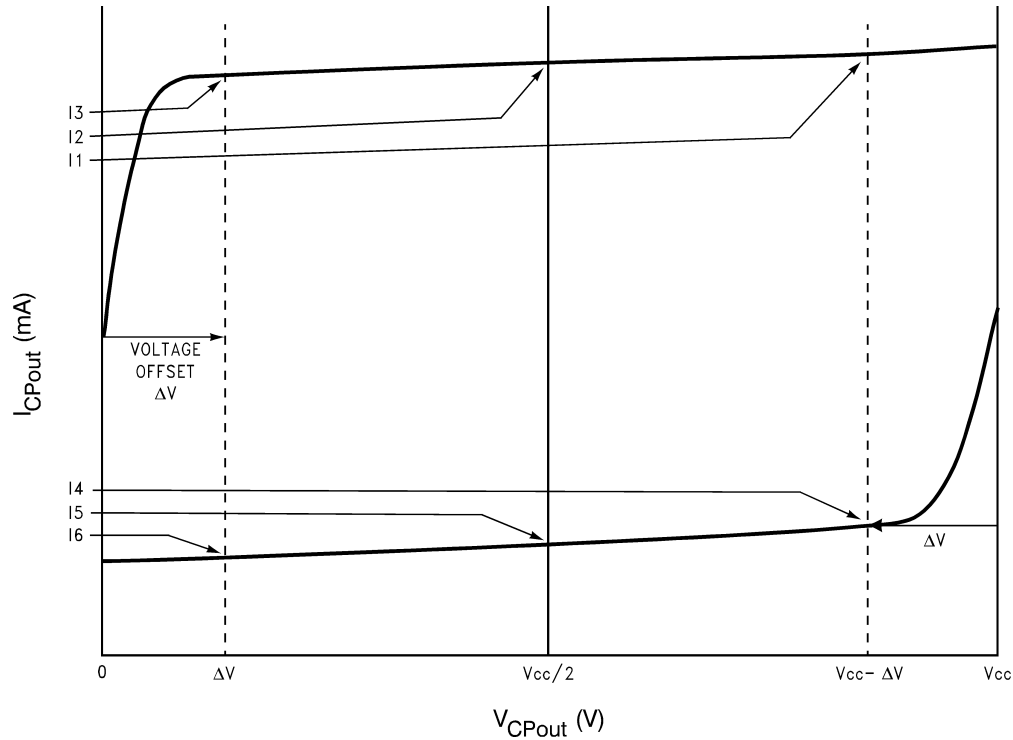

I1 = Charge Pump Sink Current at $V_{CPout} = V_{CC} - \Delta V$

I2 = Charge Pump Sink Current at $V_{CPout} = V_{CC}/2$

I3 = Charge Pump Sink Current at $V_{CPout} = \Delta V$

I4 = Charge Pump Source Current at $V_{CPout} = V_{CC} - \Delta V$

I5 = Charge Pump Source Current at $V_{CPout} = V_{CC}/2$

I6 = Charge Pump Source Current at $V_{CPout} = \Delta V$

ΔV = Voltage offset from the positive and negative supply rails. Defined to be 0.5 V for this device.

Charge Pump Output Current Magnitude Variation vs. Charge Pump Output Voltage

$$I_{CPout} \text{ Vs } V_{CPout} = \frac{|I1| - |I3|}{|I1| + |I3|} \times 100\%$$

$$= \frac{|I4| - |I6|}{|I4| + |I6|} \times 100\%$$

Charge Pump Sink Current vs. Charge Pump Output Source Current Mismatch

$$I_{CPout} \text{ Sink Vs } I_{CPout} \text{ Source} = \frac{|I2| - |I5|}{|I2| + |I5|} \times 100\%$$

Charge Pump Output Current Magnitude Variation vs. Temperature

Charge Pump Current Specification Definitions (continued)

$$I_{CPout} \text{ Vs } T_A = \frac{|I_2|_{T_A} - |I_2|_{T_A = 25^\circ\text{C}}}{|I_2|_{T_A = 25^\circ\text{C}}} \times 100\%$$

$$= \frac{|I_5|_{T_A} - |I_5|_{T_A = 25^\circ\text{C}}}{|I_5|_{T_A = 25^\circ\text{C}}} \times 100\%$$

10 Functional Description

The LMK02000 precision clock conditioner combines the functions of jitter cleaning/reconditioning, multiplication, and distribution of a reference clock. The device integrates a high performance Integer-N Phase Locked Loop (PLL), three LVDS, and five LVPECL clock output distribution blocks.

Each clock distribution block includes a programmable divider, a phase synchronization circuit, a programmable delay, a clock output mux, and an LVDS or LVPECL output buffer. This allows multiple integer-related and phase-adjusted copies of the reference to be distributed to eight system components.

The clock conditioner comes in a 48-pin WQFN package and is footprint compatible with other clocking devices in the same family.

10.1 BIAS PIN

To properly use the device, bypass Bias (pin 36) with a low leakage 1 μ F capacitor connected to Vcc. This is important for low noise performance.

10.2 LDO BYPASS

To properly use the device, bypass LDObyp1 (pin 9) with a 10 μ F capacitor and LDObyp2 (pin 10) with a 0.1 μ F capacitor.

10.3 OSCILLATOR INPUT PORT (OSCin, OSCin*)

The purpose of OSCin is to provide the PLL with a reference signal. The OSCin port must be AC coupled, refer to the System Level Diagram in the [Application Information](#) section. The OSCin port may be driven single ended by AC grounding OSCin* with a 0.1 μ F capacitor.

10.4 FREQUENCY INPUT PORT (Fin, Fin*)

The purpose of Fin is to provide the PLL with a feedback signal from an external oscillator. The Fin port may be driven single ended by AC grounding Fin*.

10.5 CLKout DELAYS

Each individual clock output includes a delay adjustment. Clock output delay registers (CLKoutX_DLY) support a 150 ps step size and range from 0 to 2250 ps of total delay.

10.6 LVDS/LVPECL OUTPUTS

Each LVDS or LVPECL output may be disabled individually by programming the CLKoutX_EN bits. All the outputs may be disabled simultaneously by pulling the GOE pin low or programming EN_CLKout_Global to 0.

10.7 GLOBAL CLOCK OUTPUT SYNCHRONIZATION

The SYNC* pin synchronizes the clock outputs. When the SYNC* pin is held in a logic low state, the divided outputs are also held in a logic low state. When the SYNC* pin goes high, the divided clock outputs are activated and will transition to a high state simultaneously. Clocks in the bypassed state are not affected by SYNC* and are always synchronized with the divided outputs.

The SYNC* pin must be held low for greater than one clock cycle of the Frequency Input port, also known as the distribution path. Once this low event has been registered, the outputs will not reflect the low state for four more cycles. Similarly once the SYNC* pin becomes high, the outputs will not simultaneously transition high until four more distribution path clock cycles have passed. See the timing diagram below for further detail. In the timing diagram below the clocks are programmed as CLKout0_MUX = Bypassed, CLKout1_MUX = Divided, CLKout1_DIV = 2, CLKout2_MUX = Divided, and CLKout2_DIV = 4.

10.8 SYNC* Timing Diagram

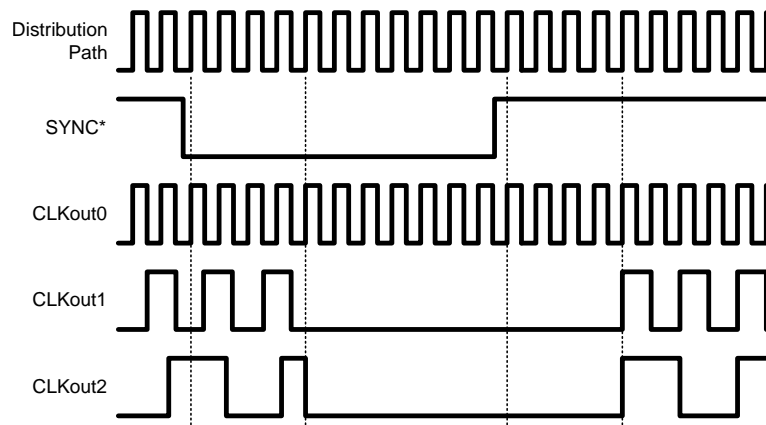

The SYNC* pin provides an internal pull-up resistor as shown on the [functional block diagram](#). If the SYNC* pin is not terminated externally the clock outputs will operate normally. If the SYNC* function is not used, clock output synchronization is not specified.

10.9 CLKout OUTPUT STATES

Each clock output may be individually enabled with the CLKoutX_EN bits. Each individual output enable control bit is gated with the Global Output Enable input pin (GOE) and the Global Output Enable bit (EN_CLKout_Global).

All clock outputs can be disabled simultaneously if the GOE pin is pulled low by an external signal or EN_CLKout_Global is set to 0.

CLKoutX_EN bit	EN_CLKout_Global bit	GOE pin	Clock X Output State
1	1	Low	Low
Don't care	0	Don't care	Off
0	Don't care	Don't care	Off
1	1	High / No Connect	Enabled

When an LVDS output is in the Off state, the outputs are at a voltage of approximately 1.5 volts. When an LVPECL output is in the Off state, the outputs are at a voltage of approximately 1 volt.

10.10 GLOBAL OUTPUT ENABLE AND LOCK DETECT

The GOE pin provides an internal pull-up resistor. If it is not terminated externally, the clock output states are determined by the Clock Output Enable bits (CLKoutX_EN) and the EN_CLKout_Global bit.

By programming the PLL_MUX register to Digital Lock Detect Active High (See [PLL_MUX\[3:0\] -- Multiplexer Control for LD Pin](#)), the Lock Detect (LD) pin can be connected to the GOE pin in which case all outputs are set low automatically if the synthesizer is not locked.

10.11 POWER ON RESET

When supply voltage to the device increases monotonically from ground to Vcc, the power on reset circuit sets all registers to their default values, see [RESET Bit -- R0 only](#) for more information on default register values. Voltage should be applied to all Vcc pins simultaneously.

10.12 General Programming Information

The LMK02000 device is programmed using several 32-bit registers which control the device's operation. The registers consist of a data field and an address field. The last 4 register bits, ADDR[3:0] form the address field. The remaining 28 bits form the data field DATA[27:0].

General Programming Information (continued)

During programming, LEuWire is low and serial data is clocked in on the rising edge of clock (MSB first). When LEuWire goes high, data is transferred to the register bank selected by the address field. Only registers R0 to R7, R11, R14, and R15 need to be programmed for proper device operation.

It is required to program register R14.

10.12.1 RECOMMENDED PROGRAMMING SEQUENCE

The recommended programming sequence involves programming R0 with the reset bit set (RESET = 1) to ensure the device is in a default state. It is not necessary to program R0 again, but if R0 is programmed again, the reset bit is programmed clear (RESET = 0). Registers are programmed in order with R15 being the last register programmed. An example programming sequence is shown below.

- Program R0 with the reset bit set (RESET = 1). This ensures the device is in a default state. When the reset bit is set in R0, the other R0 bits are ignored.
 - If R0 is programmed again, the reset bit is programmed clear (RESET = 0).
- Program R0 to R7 as necessary with desired clocks with appropriate enable, mux, divider, and delay settings.
- Program R11 with DIV4 setting if necessary.
- Program R14 with global clock output bit, power down setting, PLL mux setting, and PLL R divider. It is required to program register R14.
 - R14 must be programmed in accordance with the register map as shown in the register map (see [Table 1](#)).
- Program R15 with PLL charge pump gain, and PLL N divider.

Table 1. LMK02000 REGISTER MAP

Register	31	30	29	28	27	26	25	24	23	22	21	20	19	18	17	16	15	14	13	12	11	10	9	8	7	6	5	4	3	2	1	0	
	Data [27:0]																											A3	A2	A1	A0		
R0	RE SE T	0	0	0	0	0	0	0	0	0	0	0	0	0	0	0	0	0	0	0	0	0	0	0	0	0	0	0	0	0	0		
R1	0	0	0	0	0	0	0	0	0	0	0	0	0	0	0	0	0	0	0	0	0	0	0	0	0	0	0	0	0	0	1		
R2	0	0	0	0	0	0	0	0	0	0	0	0	0	0	0	0	0	0	0	0	0	0	0	0	0	0	0	0	1	0	0		
R3	0	0	0	0	0	0	0	0	0	0	0	0	0	0	0	0	0	0	0	0	0	0	0	0	0	0	0	0	0	1	1		
R4	0	0	0	0	0	0	0	0	0	0	0	0	0	0	0	0	0	0	0	0	0	0	0	0	0	0	0	0	1	0	0		
R5	0	0	0	0	0	0	0	0	0	0	0	0	0	0	0	0	0	0	0	0	0	0	0	0	0	0	0	0	1	0	1		
R6	0	0	0	0	0	0	0	0	0	0	0	0	0	0	0	0	0	0	0	0	0	0	0	0	0	0	0	0	1	1	0		
R7	0	0	0	0	0	0	0	0	0	0	0	0	0	0	0	0	0	0	0	0	0	0	0	0	0	0	0	0	1	1	1		
R11	0	0	0	0	0	0	0	0	1	0	0	0	0	0	1	0	DIV 4	0	0	0	0	0	0	0	0	0	0	0	0	1	0	1	1
R14	0	0	1	0	EN _CL Kou t_Gl oba l	PO WE RD OW N	TRI - ST AT E	PLL _C P _P O L	PLL_MUX [3:0]			PLL_R [11:0]											0	0	0	0	1	1	1	0			

Table 1. LMK02000 REGISTER MAP (continued)

Re gist er	31	30	29	28	27	26	25	24	23	22	21	20	19	18	17	16	15	14	13	12	11	10	9	8	7	6	5	4	3	2	1	0				
R15	PLL_ CP_ GAIN [1:0]		0	0	0	0	PLL_N [17:0]														0	0	0	0	1	1	1	1								

10.12.2 REGISTER R0 to R7

Registers R0 through R7 control the eight clock outputs. Register R0 controls CLKout0, Register R1 controls CLKout1, and so on. There is one additional bit in register R0 called RESET. Aside from this, the functions of these bits are identical. The X in CLKoutX_MUX, CLKoutX_DIV, CLKoutX_DLY, and CLKoutX_EN denote the actual clock output which may be from 0 to 7.

10.12.2.1 RESET Bit -- R0 only

This bit is only in register R0. The use of this bit is optional and it should be set to '0' if not used. Setting this bit to a '1' forces all registers to their power on reset condition and therefore automatically clears this bit. If this bit is set, all other R0 bits are ignored and R0 needs to be programmed again if used with its proper values and RESET = 0.

Bit Name	Default Bit Value	Bit State	Bit Description	Register	Bit Location
RESET	0	No reset, normal operation	Reset to power on defaults	R0	31
CLKoutX_MUX	0	Bypassed	CLKoutX mux mode	R0 to R7	18:17
CLKoutX_EN	0	Disabled	CLKoutX enable		16
CLKoutX_DIV	1	Divide by 2	CLKoutX clock divide		15:8
CLKoutX_DLY	0	0 ps	CLKoutX clock delay		7:4
DIV4	0	PDF \leq 20 MHz	Phase Detector Frequency		R11
EN_CLKout_Global	1	Normal - CLKouts normal	Global clock output enable	R14	27
POWERDOWN	0	Normal - Device active	Device power down		26
PLL_CP_TRI	0	Normal - PLL active	TRI-STATE PLL charge pump		25
PLL_CP_POL	0	Negative Polarity CP	Polarity of charge pump		24
PLL_MUX	0	Disabled	Multiplexer control for LD pin		23:20
PLL_R	10	R divider = 10	PLL R divide value	R15	19:8
PLL_CP_GAIN	0	100 μ A	Charge pump current		31:30
PLL_N	760	N divider = 760	PLL N divide value		25:8

10.12.2.2 CLKoutX_MUX[1:0] -- Clock Output Multiplexers

These bits control the Clock Output Multiplexer for each clock output. Changing between the different modes changes the blocks in the signal path and therefore incurs a delay relative to the bypass mode. The different MUX modes and associated delays are listed below.

CLKoutX_MUX[1:0]	Mode	Added Delay Relative to Bypass Mode
0	Bypassed (default)	0 ps
1	Divided	100 ps
2	Delayed	400 ps (In addition to the programmed delay)
3	Divided and Delayed	500 ps (In addition to the programmed delay)

10.12.2.3 CLKoutX_DIV[7:0] -- Clock Output Dividers

These bits control the clock output divider value. In order for these dividers to be active, the respective CLKoutX_MUX (See [CLKoutX_MUX\[1:0\] -- Clock Output Multiplexers](#)) bit must be set to either "Divided" or "Divided and Delayed" mode. After all the dividers are programmed, the SYNC* pin must be used to ensure that all edges of the clock outputs are aligned (See [GLOBAL CLOCK OUTPUT SYNCHRONIZATION](#)). By adding the divider block to the output path a fixed delay of approximately 100 ps is incurred.

The actual Clock Output Divide value is twice the binary value programmed as listed in the table below.

CLKoutX_DIV[7:0]								Clock Output Divider value
0	0	0	0	0	0	0	0	Invalid
0	0	0	0	0	0	0	1	2 (default)
0	0	0	0	0	0	1	0	4
0	0	0	0	0	0	1	1	6
0	0	0	0	0	1	0	0	8
0	0	0	0	0	1	0	1	10
.
1	1	1	1	1	1	1	1	510

10.12.2.4 CLKoutX_DLY[3:0] -- Clock Output Delays

These bits control the delay stages for each clock output. In order for these delays to be active, the respective CLKoutX_MUX (See [CLKoutX_MUX\[1:0\] -- Clock Output Multiplexers](#)) bit must be set to either "Delayed" or "Divided and Delayed" mode. By adding the delay block to the output path a fixed delay of approximately 400 ps is incurred in addition to the delay shown in the table below.

CLKoutX_DLY[3:0]	Delay (ps)
0	0 (default)
1	150
2	300
3	450
4	600
5	750
6	900
7	1050
8	1200
9	1350
10	1500
11	1650
12	1800
13	1950
14	2100
15	2250

10.12.2.5 CLKoutX_EN bit -- Clock Output Enables

These bits control whether an individual clock output is enabled or not. If the EN_CLKout_Global bit (See [EN_CLKout_Global Bit -- Global Clock Output Enable](#)) is set to zero or if GOE pin is held low, all CLKoutX_EN bit states will be ignored and all clock outputs will be disabled. See [CLKout OUTPUT STATES](#) for more information on CLKout states.

CLKoutX_EN bit	Conditions	CLKoutX State
0	EN_CLKout_Global bit = 1 GOE pin = High / No Connect 1	Disabled (default)
1		Enabled

10.12.3 REGISTER R11

This register only has one bit and only needs to be programmed in the case that the phase detector frequency is greater than 20 MHz and digital lock detect is used. Otherwise, it is automatically defaulted to the correct values.

10.12.3.1 DIV4

This bit divides the frequency presented to the digital lock detect circuitry by 4. It is necessary to get a reliable output from the digital lock detect output in the case of a phase detector frequency greater than 20 MHz.

DIV4	Digital Lock Detect Circuitry Mode
0	Not divided; Phase detector frequency \leq 20 MHz (default)
1	Divided by 4; Phase detector frequency $>$ 20 MHz

10.12.4 REGISTER R14

The LMK02000 requires register R14 to be programmed as shown in the register map (see [Table 1](#)).

10.12.4.1 PLL_R[11:0] -- R Divider Value

These bits program the PLL R Divider and are programmed in binary fashion.

PLL_R[11:0]											PLL R Divide Value	
0	0	0	0	0	0	0	0	0	0	0	0	Invalid
0	0	0	0	0	0	0	0	0	0	0	1	1
0	0	0	0	0	0	0	0	0	0	1	0	2
.
0	0	0	0	0	0	0	0	1	0	1	0	10 (default)
.
1	1	1	1	1	1	1	1	1	1	1	1	4095

10.12.4.2 PLL_MUX[3:0] -- Multiplexer Control for LD Pin

These bits set the output mode of the LD pin. The table below lists several different modes.

PLL_MUX[3:0]	Output Type	LD Pin Function
0	Hi-Z	Disabled (default)
1	Push-Pull	Logic High
2	Push-Pull	Logic Low
3	Push-Pull	Digital Lock Detect (Active High)
4	Push-Pull	Digital Lock Detect (Active Low)
5	Push-Pull	Analog Lock Detect
6	Open Drain NMOS	Analog Lock Detect
7	Open Drain PMOS	Analog Lock Detect
8		Invalid
9	Push-Pull	N Divider Output/2 (50% Duty Cycle)
10		Invalid
11	Push-Pull	R Divider Output/2 (50% Duty Cycle)
12 to 15		Invalid

10.12.4.3 POWERDOWN Bit -- Device Power Down

This bit can power down the device. Enabling this bit powers down the entire device and all blocks, regardless of the state of any of the other bits or pins.

POWERDOWN bit	Mode
0	Normal Operation (default)
1	Entire Device Powered Down

10.12.4.4 EN_CLKout_Global Bit -- Global Clock Output Enable

This bit overrides the individual CLKoutX_EN bits (See [CLKoutX_EN bit -- Clock Output Enables](#)). When this bit is set to 0, all clock outputs are disabled, regardless of the state of any of the other bits or pins. See [CLKout OUTPUT STATES](#) for more information on CLKout states.

EN_CLKout_Global bit	Clock Outputs
0	All Off
1	Normal Operation (default)

10.12.4.5 PLL_CP_TRI Bit -- PLL Charge Pump TRI-STATE

This bit sets the PLL charge pump TRI-STATE.

PLL_CP_TRI	PLL Charge Pump
0	Normal operation (default)
1	TRI-STATE

10.12.4.6 PLL_CP_POLBbit -- PLL Charge Pump Polarity

This bit sets the polarity of the charge pump to either negative or positive. A negative charge pump is used with a VCO or VCXO which decreases frequency with increasing tuning voltage. A positive charge pump is used with a VCO or VCXO which increases frequency with increasing tuning voltage.

PLL_CP_POL	PLL Charge Pump Polarity
0	Negative (default)
1	Positive

10.12.5 Register R15

10.12.5.1 PLL_N[17:0] -- PLL N Divider

These bits program the divide value for the PLL N Divider. The PLL N Divider precedes the PLL phase detector. The VCO or VCXO frequency is calculated as, $f_{VCO} = f_{OSCin} \times \text{PLL N Divider} / \text{PLL R Divider}$. Since the PLL N divider is a pure binary counter, there are no illegal divide values for PLL_N[17:0] except for 0.

PLL_N[17:0]																	PLL N Divider Value	
0	0	0	0	0	0	0	0	0	0	0	0	0	0	0	0	0	0	Invalid
0	0	0	0	0	0	0	0	0	0	0	0	0	0	0	0	0	1	1
.
0	0	0	0	0	0	0	0	1	0	1	1	1	1	1	0	0	0	760 (default)
.
1	1	1	1	1	1	1	1	1	1	1	1	1	1	1	1	1	1	262143

10.12.5.2 PLL_CP_GAIN[1:0] -- PLL Charge Pump Gain

These bits set the charge pump gain of the PLL.

PLL_CP_GAIN[1:0]	Charge Pump Gain
0	1x (default)
1	4x
2	16x
3	32x

11 Application Information

11.1 SYSTEM LEVEL DIAGRAM

The following shows the LMK02000 in a typical application. In this setup the clock may be multiplied, reconditioned, and redistributed.

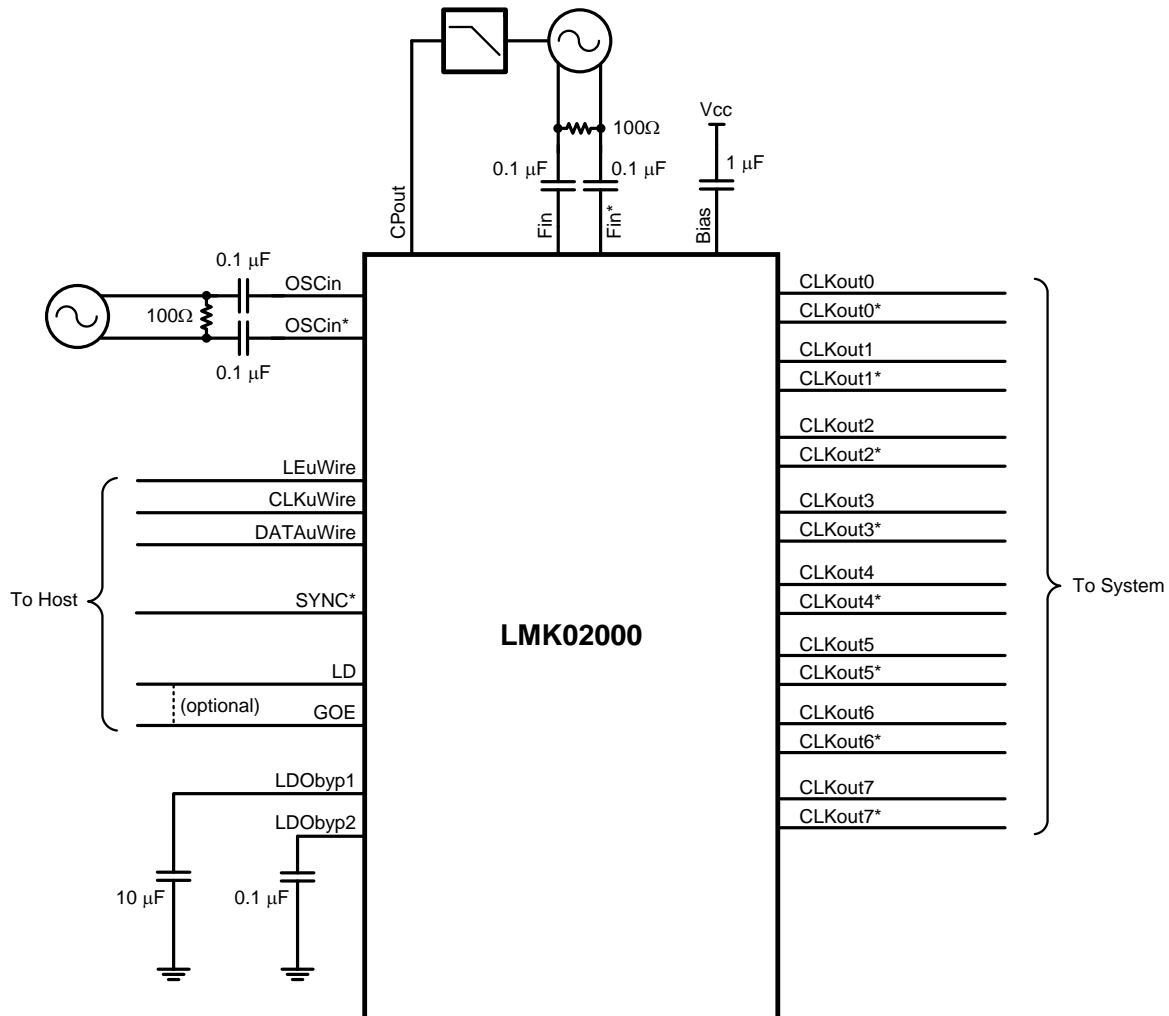

Figure 2. Typical Application

11.2 BIAS PIN

To properly use the device, bypass Bias (pin 36) with a low leakage 1 μ F capacitor connected to Vcc. This is important for low noise performance.

11.3 LDO BYPASS

To properly use the device, bypass LDObyp1 (pin 9) with a 10 μ F capacitor and LDObyp2 (pin 10) with a 0.1 μ F capacitor.

11.4 CURRENT CONSUMPTION / POWER DISSIPATION CALCULATIONS

Due to the myriad of possible configurations the following table serves to provide enough information to allow the user to calculate estimated current consumption of the LMK02000. Unless otherwise noted Vcc = 3.3 V, T_A = 25 °C.

CURRENT CONSUMPTION / POWER DISSIPATION CALCULATIONS (continued)
Table 2. Block Current Consumption

Block	Condition	Current Consumption at 3.3 V (mA)	Power Dissipated in device (mW)	Power Dissipated in LVPECL emitter resistors (mW)
Entire device, core current	All outputs off; No LVPECL emitter resistors connected	70	231	-
Low clock buffer (internal)	The low clock buffer is enabled anytime one of CLKout0 through CLKout3 are enabled	9	29.7	-
High clock buffer (internal)	The high clock buffer is enabled anytime one of the CLKout4 through CLKout7 are enabled	9	29.7	-
Output buffers	LVDS output, bypass mode	17.8	58.7	-
	LVPECL output, bypass mode (includes 120 Ω emitter resistors)	40	72	60
	LVPECL output, disabled mode (includes 120 Ω emitter resistors)	17.4	38.3	19.1
	LVPECL output, disabled mode. No emitter resistors placed; open outputs	0	0	-
Divide circuitry per output	Divide enabled, divide = 2	5.3	17.5	-
	Divide enabled, divide > 2	8.5	28.0	-
Delay circuitry per output	Delay enabled, delay < 8	5.8	19.1	-
	Delay enabled, delay > 7	9.9	32.7	-
Entire device	CLKout0 & CLKout4 enabled in bypass mode	145.8	421.1	60

From [Table 2](#) the current consumption can be calculated in any configuration. For example, the current for the entire device with 1 LVDS (CLKout0) & 1 LVPECL (CLKout4) output in bypass mode can be calculated by adding up the following blocks: core current, low clock buffer, high clock buffer, one LVDS output buffer current, and one LVPECL output buffer current. There will also be one LVPECL output drawing emitter current, but some of the power from the current draw is dissipated in the external 120 Ω resistors which doesn't add to the power dissipation budget for the device. If delays or divides are switched in, then the additional current for these stages needs to be added as well.

For power dissipated by the device, the total current entering the device is multiplied by the voltage at the device minus the power dissipated in any emitter resistors connected to any of the LVPECL outputs. If no emitter resistors are connected to the LVPECL outputs, this power will be 0 watts. For example, in the case of 1 LVDS (CLKout0) & 1 LVPECL (CLKout4) operating at 3.3 volts, we calculate $3.3 \text{ V} \times (70 + 9 + 9 + 17.8 + 40) \text{ mA} = 3.3 \text{ V} \times 145.8 \text{ mA} = 481.1 \text{ mW}$. Because the LVPECL output (CLKout4) has the emitter resistors hooked up and the power dissipated by these resistors is 60 mW, the total device power dissipation is $481.1 \text{ mW} - 60 \text{ mW} = 421.1 \text{ mW}$.

When the LVPECL output is active, ~1.9 V is the average voltage on each output as calculated from the LVPECL V_{oh} & V_{ol} typical specification. Therefore the power dissipated in each emitter resistor is approximately $(1.9 \text{ V})^2 / 120 \Omega = 30 \text{ mW}$. When the LVPECL output is disabled, the emitter resistor voltage is ~1.07 V. Therefore the power dissipated in each emitter resistor is approximately $(1.07 \text{ V})^2 / 120 \Omega = 9.5 \text{ mW}$.

11.5 THERMAL MANAGEMENT

Power consumption of the LMK02000 can be high enough to require attention to thermal management. For reliability and performance reasons the die temperature should be limited to a maximum of 125 °C. That is, as an estimate, T_A (ambient temperature) plus device power consumption times θ_{JA} should not exceed 125 °C.

The package of the device has an exposed pad that provides the primary heat removal path as well as excellent electrical grounding to the printed circuit board. To maximize the removal of heat from the package a thermal land pattern including multiple vias to a ground plane must be incorporated on the PCB within the footprint of the package. The exposed pad must be soldered down to ensure adequate heat conduction out of the package. A recommended land and via pattern is shown in [Figure 3](#). More information on soldering WQFN packages can be obtained at www.ti.com.

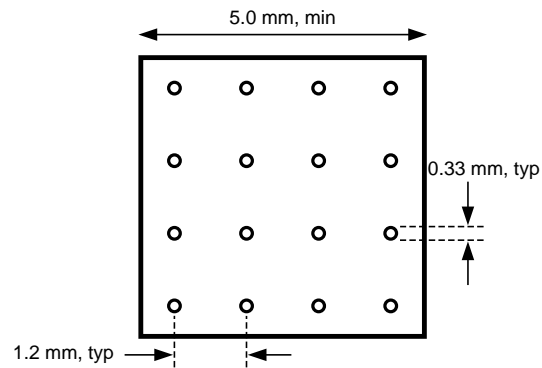
THERMAL MANAGEMENT (continued)**Figure 3.**

To minimize junction temperature it is recommended that a simple heat sink be built into the PCB (if the ground plane layer is not exposed). This is done by including a copper area of about 2 square inches on the opposite side of the PCB from the device. This copper area may be plated or solder coated to prevent corrosion but should not have conformal coating (if possible), which could provide thermal insulation. The vias shown in [Figure 3](#) should connect these top and bottom copper layers and to the ground layer. These vias act as “heat pipes” to carry the thermal energy away from the device side of the board to where it can be more effectively dissipated.

PACKAGING INFORMATION

Orderable Device	Status (1)	Package Type	Package Drawing	Pins	Package Qty	Eco Plan (2)	Lead/Ball Finish (6)	MSL Peak Temp (3)	Op Temp (°C)	Device Marking (4/5)	Samples
LMK02000ISQ/NOPB	ACTIVE	WQFN	RHS	48	250	Green (RoHS & no Sb/Br)	CU SN	Level-3-260C-168 HR	-40 to 85	K02000 I	Samples

(1) The marketing status values are defined as follows:

ACTIVE: Product device recommended for new designs.

LIFEBUY: TI has announced that the device will be discontinued, and a lifetime-buy period is in effect.

NRND: Not recommended for new designs. Device is in production to support existing customers, but TI does not recommend using this part in a new design.

PREVIEW: Device has been announced but is not in production. Samples may or may not be available.

OBSOLETE: TI has discontinued the production of the device.

(2) **RoHS:** TI defines "RoHS" to mean semiconductor products that are compliant with the current EU RoHS requirements for all 10 RoHS substances, including the requirement that RoHS substance do not exceed 0.1% by weight in homogeneous materials. Where designed to be soldered at high temperatures, "RoHS" products are suitable for use in specified lead-free processes. TI may reference these types of products as "Pb-Free".

RoHS Exempt: TI defines "RoHS Exempt" to mean products that contain lead but are compliant with EU RoHS pursuant to a specific EU RoHS exemption.

Green: TI defines "Green" to mean the content of Chlorine (Cl) and Bromine (Br) based flame retardants meet JS709B low halogen requirements of <=1000ppm threshold. Antimony trioxide based flame retardants must also meet the <=1000ppm threshold requirement.

(3) MSL, Peak Temp. - The Moisture Sensitivity Level rating according to the JEDEC industry standard classifications, and peak solder temperature.

(4) There may be additional marking, which relates to the logo, the lot trace code information, or the environmental category on the device.

(5) Multiple Device Markings will be inside parentheses. Only one Device Marking contained in parentheses and separated by a "~" will appear on a device. If a line is indented then it is a continuation of the previous line and the two combined represent the entire Device Marking for that device.

(6) Lead/Ball Finish - Orderable Devices may have multiple material finish options. Finish options are separated by a vertical ruled line. Lead/Ball Finish values may wrap to two lines if the finish value exceeds the maximum column width.

Important Information and Disclaimer:The information provided on this page represents TI's knowledge and belief as of the date that it is provided. TI bases its knowledge and belief on information provided by third parties, and makes no representation or warranty as to the accuracy of such information. Efforts are underway to better integrate information from third parties. TI has taken and continues to take reasonable steps to provide representative and accurate information but may not have conducted destructive testing or chemical analysis on incoming materials and chemicals. TI and TI suppliers consider certain information to be proprietary, and thus CAS numbers and other limited information may not be available for release.

In no event shall TI's liability arising out of such information exceed the total purchase price of the TI part(s) at issue in this document sold by TI to Customer on an annual basis.

TAPE AND REEL INFORMATION



QUADRANT ASSIGNMENTS FOR PIN 1 ORIENTATION IN TAPE



*All dimensions are nominal

Device	Package Type	Package Drawing	Pins	SPQ	Reel Diameter (mm)	Reel Width W1 (mm)	A0 (mm)	B0 (mm)	K0 (mm)	P1 (mm)	W (mm)	Pin1 Quadrant
LMK02000ISQ/NOPB	WQFN	RHS	48	250	178.0	16.4	7.3	7.3	1.3	12.0	16.0	Q1

TAPE AND REEL BOX DIMENSIONS



*All dimensions are nominal

Device	Package Type	Package Drawing	Pins	SPQ	Length (mm)	Width (mm)	Height (mm)
LMK020001SQ/NOPB	WQFN	RHS	48	250	210.0	185.0	35.0

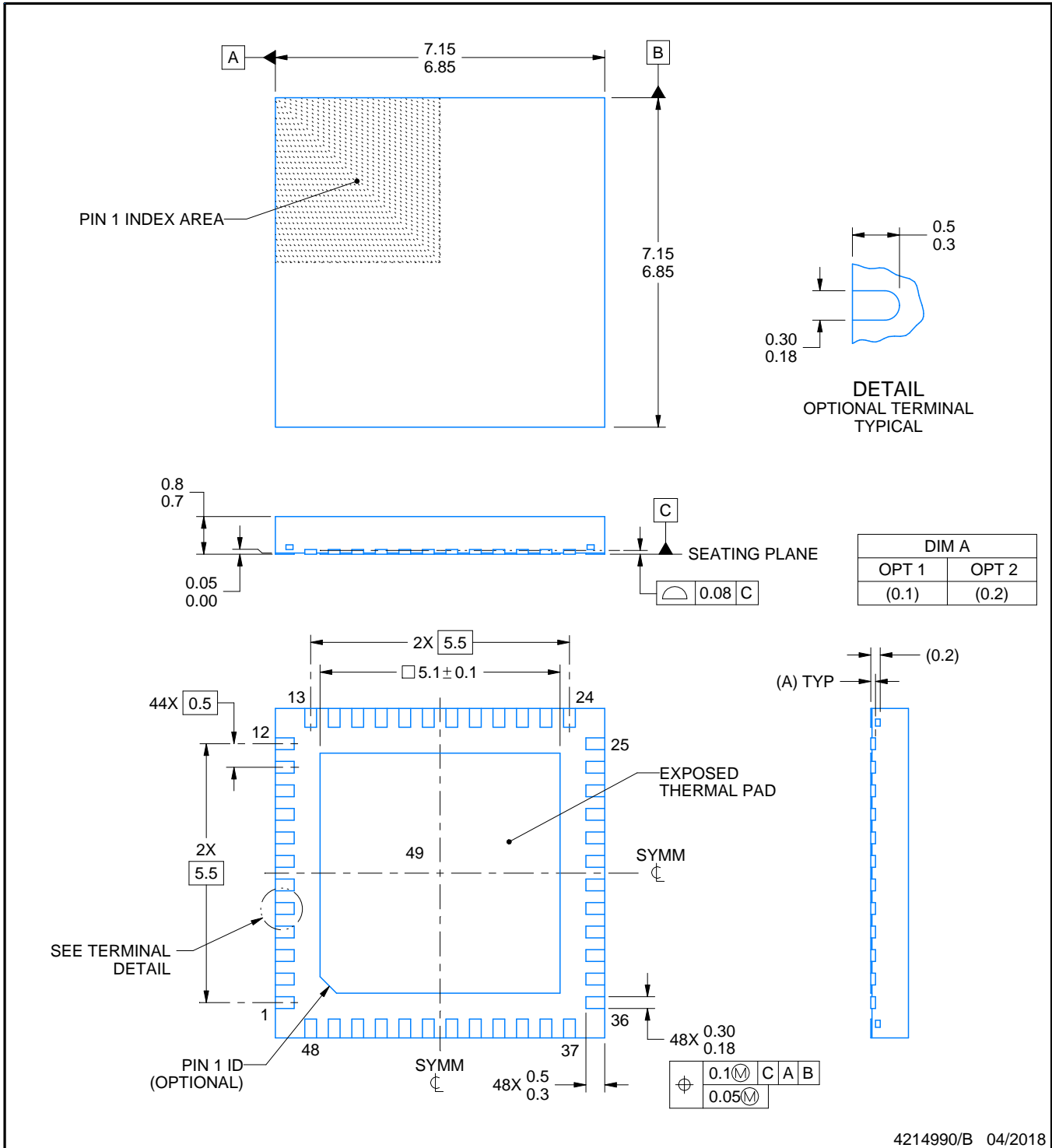
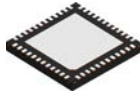

4214990/B 04/2018

NOTES:

1. All linear dimensions are in millimeters. Any dimensions in parenthesis are for reference only. Dimensioning and tolerancing per ASME Y14.5M.
2. This drawing is subject to change without notice.
3. The package thermal pad must be soldered to the printed circuit board for thermal and mechanical performance.

EXAMPLE BOARD LAYOUT

RHS0048A

WQFN - 0.8 mm max height

PLASTIC QUAD FLATPACK - NO LEAD

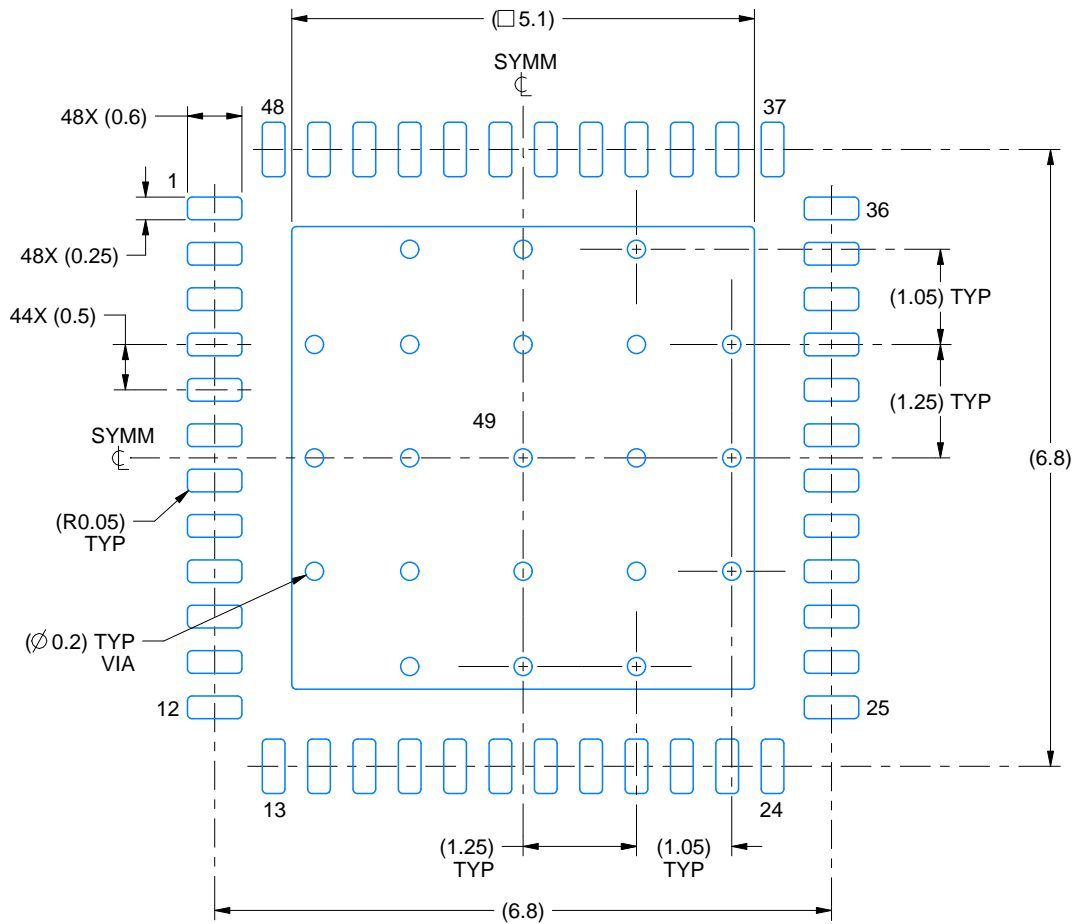

LAND PATTERN EXAMPLE
EXPOSED METAL SHOWN
SCALE:12X

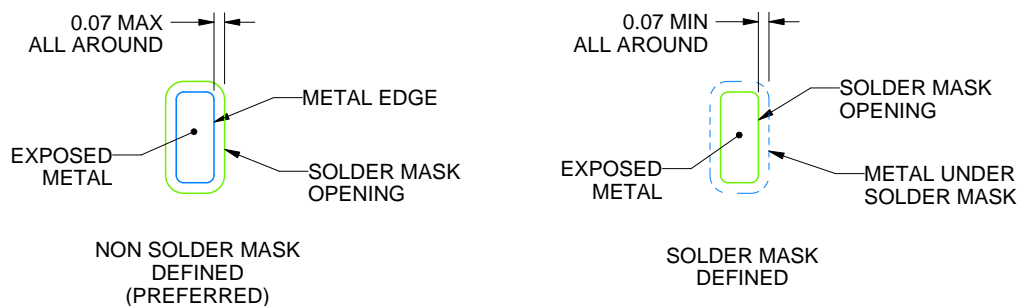

SOLDER MASK DETAILS

4214990/B 04/2018

NOTES: (continued)

4. This package is designed to be soldered to a thermal pad on the board. For more information, see Texas Instruments literature number SLUA271 (www.ti.com/lit/slua271).
5. Vias are optional depending on application, refer to device data sheet. If any vias are implemented, refer to their locations shown on this view. It is recommended that vias under paste be filled, plugged or tented.

EXAMPLE STENCIL DESIGN

RHS0048A

WQFN - 0.8 mm max height

PLASTIC QUAD FLATPACK - NO LEAD

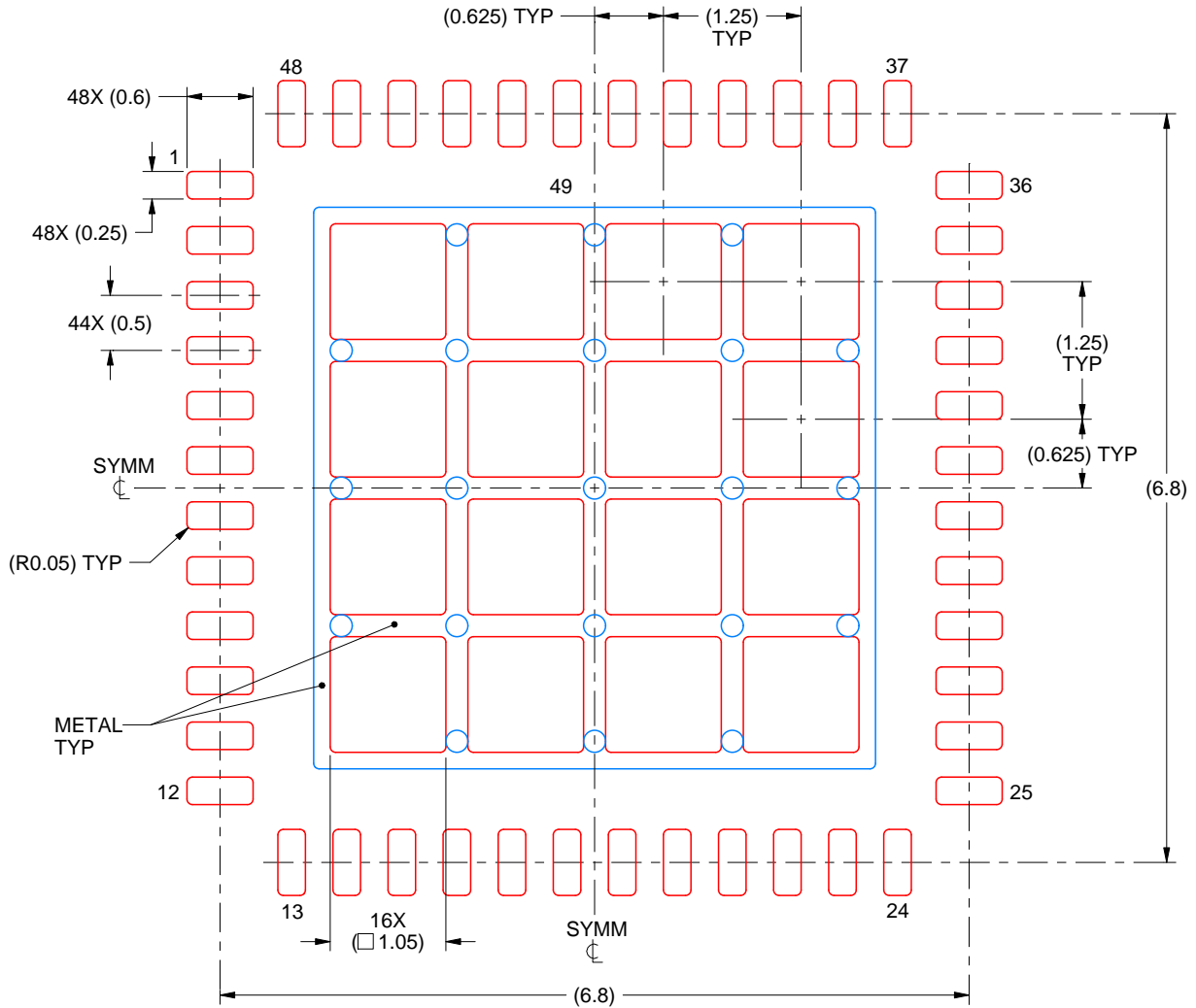

SOLDER PASTE EXAMPLE
BASED ON 0.125 mm THICK STENCIL

EXPOSED PAD 49
68% PRINTED SOLDER COVERAGE BY AREA UNDER PACKAGE
SCALE:15X

4214990/B 04/2018

NOTES: (continued)

6. Laser cutting apertures with trapezoidal walls and rounded corners may offer better paste release. IPC-7525 may have alternate design recommendations.

IMPORTANT NOTICE AND DISCLAIMER

TI PROVIDES TECHNICAL AND RELIABILITY DATA (INCLUDING DATASHEETS), DESIGN RESOURCES (INCLUDING REFERENCE DESIGNS), APPLICATION OR OTHER DESIGN ADVICE, WEB TOOLS, SAFETY INFORMATION, AND OTHER RESOURCES "AS IS" AND WITH ALL FAULTS, AND DISCLAIMS ALL WARRANTIES, EXPRESS AND IMPLIED, INCLUDING WITHOUT LIMITATION ANY IMPLIED WARRANTIES OF MERCHANTABILITY, FITNESS FOR A PARTICULAR PURPOSE OR NON-INFRINGEMENT OF THIRD PARTY INTELLECTUAL PROPERTY RIGHTS.

These resources are intended for skilled developers designing with TI products. You are solely responsible for (1) selecting the appropriate TI products for your application, (2) designing, validating and testing your application, and (3) ensuring your application meets applicable standards, and any other safety, security, or other requirements. These resources are subject to change without notice. TI grants you permission to use these resources only for development of an application that uses the TI products described in the resource. Other reproduction and display of these resources is prohibited. No license is granted to any other TI intellectual property right or to any third party intellectual property right. TI disclaims responsibility for, and you will fully indemnify TI and its representatives against, any claims, damages, costs, losses, and liabilities arising out of your use of these resources.

TI's products are provided subject to TI's Terms of Sale (www.ti.com/legal/termsofsale.html) or other applicable terms available either on ti.com or provided in conjunction with such TI products. TI's provision of these resources does not expand or otherwise alter TI's applicable warranties or warranty disclaimers for TI products.

Mailing Address: Texas Instruments, Post Office Box 655303, Dallas, Texas 75265
Copyright © 2018, Texas Instruments Incorporated

Looking for pricing, stock, or lifecycle information?

Click below to explore more details on WIN SOURCE:

- ⊖ [View LMK02000ISQ/NOPB on WIN SOURCE](#)
- ⊖ [Texas Instruments](#) Information

Optimize Your Supply Chain with WIN SOURCE Solutions

- ✓ Global Sourcing Solution
- ✓ Obsolete Management
- ✓ Cost Control Management
- ✓ Shortage Management
- ✓ Alternative Solution
- ✓ Excess Inventory Management