



**THE DATASHEET OF  
LM95241C1MM-2/NOPB**



# LM95241 Dual Remote Diode Temperature Sensor with SMBus Interface and TruTherm™ Technology (65nm/90nm)

Check for Samples: [LM95241](#)

## FEATURES

- Accurately Senses Die Temperature of Remote ICs or Diode Junctions
- Uses TruTherm Technology for Precision “Thermal Diode” Temperature Measurement
- Thermal Diode Input Stage with Analog Filtering
- Thermal Diode Digital Filtering
- Intel Processor on 65nm or 90nm Process or 2N3904 Non-Ideality Selection
- Remote Diode Fault Detection
- On-board Local Temperature Sensing
- Remote Temperature Readings Without Digital Filtering:
  - 0.125 °C LSb
  - 10-bits Plus Sign or 11-bits Programmable Resolution
  - 11-bits Resolves Temperatures Above 127 °C
- Remote Temperature Readings with Digital Filtering:
  - 0.03125 °C LSb with Filtering
  - 12-bits Plus Sign or 13-bits Programmable Resolution
  - 13-bits Resolves Temperatures Above 127 °C
- Local Temperature Readings:
  - 0.25 °C
  - 9-bits Plus Sign
- Status Register Support
- Programmable Conversion Rate Allows User Optimization of Power Consumption
- Shutdown Mode One-shot Conversion Control
- SMBus 2.0 Compatible Interface, Supports TIMEOUT
- 8-pin VSSOP Package

## KEY SPECIFICATIONS

- Remote Diode Temperature Accuracy
  - $T_A = 20^{\circ}\text{C}$  to  $40^{\circ}\text{C}$ ,  $T_D = 45^{\circ}\text{C}$  to  $85^{\circ}\text{C} \pm 1.25^{\circ}\text{C}$  (Max)
  - $T_A = 0^{\circ}\text{C}$  to  $85^{\circ}\text{C}$ ,  $T_D = 25^{\circ}\text{C}$  to  $140^{\circ}\text{C} \pm 2.5^{\circ}\text{C}$  (Max)
- Local Temperature Accuracy
  - $T_A = 0^{\circ}\text{C}$  to  $85^{\circ}\text{C} \pm 3.0^{\circ}\text{C}$  (Max)
- Supply Voltage 3.0 V to 3.6 V
- Average Supply Current 471  $\mu\text{A}$  (Typ)

## APPLICATIONS

- Processor/Computer System Thermal Management
  - (e.g. Laptop, Desktop, Workstations, Server)
- Electronic Test Equipment
- Office Electronics

## DESCRIPTION

The LM95241 is a precision dual remote diode temperature sensor (RDTs) that uses TI's TruTherm technology. The 2-wire serial interface of the LM95241 is compatible with SMBus 2.0. The LM95241 can sense three temperature zones, it can measure the temperature of its own die as well as two diode connected transistors. The LM95241 includes digital filtering and an advanced input stage that includes analog filtering and TruTherm technology that reduces processor-to-processor non-ideality spread. The diode connected transistors can be a “thermal diode” as found in Intel and AMD processors or can simply be a diode connected MMBT3904 transistor. TruTherm technology allows accurate measurement of “thermal diodes” found on small geometry processes such as 90nm and 65nm. The LM95241 supports user selectable thermal diode non-ideality of either Intel processor on 90nm or 65nm process or 2N3904.



Please be aware that an important notice concerning availability, standard warranty, and use in critical applications of Texas Instruments semiconductor products and disclaimers thereto appears at the end of this data sheet.

All trademarks are the property of their respective owners.

## DESCRIPTION (CONTINUED)

The LM95241 resolution format for remote temperature readings can be programmed to be 11-bits signed or unsigned with the digital filtering disabled. When the filtering is enabled the resolution increases to 13-bits signed or unsigned. In the unsigned mode the LM95241 remote diode readings can resolve temperatures above 127°C. Local temperature readings have a resolution of 9-bits plus sign.

## Connection Diagram

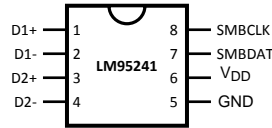
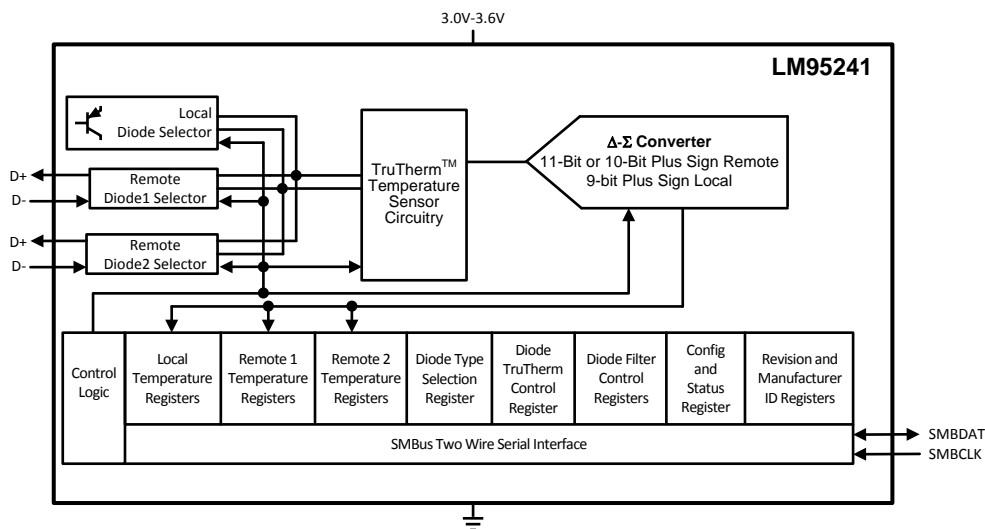

**Figure 1. VSSOP-8  
TOP VIEW**

## PIN DESCRIPTIONS

| Label           | Pin # | Function  | Typical Connection  |
|-----------------|-------|---|---|
| D1+             | 1     | Diode Current Source                              | To Diode Anode. Connected to remote discrete diode-connected transistor junction or to the diode-connected transistor junction on a remote IC whose die temperature is being sensed. A capacitor is not required between D1+ and D1-. A 100 pF capacitor between D1+ and D1- can be added and may improve performance in noisy systems. |
| D1-             | 2     | Diode Return Current Sink                         | To Diode Cathode. A capacitor is not required between D1+ and D1-. A 100 pF capacitor between D1+ and D1- can be added and may improve performance in noisy systems.  |
| D2+             | 3     | Diode Current Source                              | To Diode Anode. Connected to remote discrete diode-connected transistor junction or to the diode-connected transistor junction on a remote IC whose die temperature is being sensed. A capacitor is not required between D2+ and D2-. A 100 pF capacitor between D2+ and D2- can be added and may improve performance in noisy systems. |
| D2-             | 4     | Diode Return Current Sink                         | To Diode Cathode. A capacitor is not required between D2+ and D2-. A 100 pF capacitor between D2+ and D2- can be added and may improve performance in noisy systems.  |
| GND             | 5     | Power Supply Ground                               | System low noise ground   |
| V <sub>DD</sub> | 6     | Positive Supply Voltage Input                     | DC Voltage from 3.0 V to 3.6 V. V <sub>DD</sub> should be bypassed with a 0.1 μF capacitor in parallel with 100 pF. The 100 pF capacitor should be placed as close as possible to the power supply pin. Noise should be kept below 200 mVp-p, a 10 μF capacitor may be required to achieve this.  |
| SMBDAT          | 7     | SMBus Bi-Directional Data Line, Open-Drain Output | From and to Controller; may require an external pull-up resistor  |
| SMBCLK          | 8     | SMBus Clock Input                                 | From Controller; may require an external pull-up resistor   |

## Simplified Block Diagram



## Typical Application

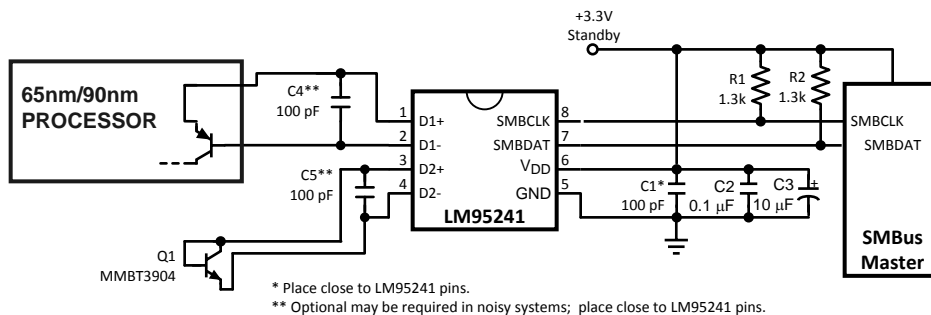

These devices have limited built-in ESD protection. The leads should be shorted together or the device placed in conductive foam during storage or handling to prevent electrostatic damage to the MOS gates.

### Absolute Maximum Ratings<sup>(1)</sup>

|  |                            |                                     |
|--|----------------------------|-------------------------------------|
| Supply Voltage   |                            | -0.3 V to 6.0 V                     |
| Voltage at SMBDAT, SMBCLK  |                            | -0.5V to 6.0V                       |
| Voltage at Other Pins  |                            | -0.3 V to (V <sub>DD</sub> + 0.3 V) |
| Input Current at All Pins <sup>(2)</sup>   |                            | ±5 mA                               |
| Package Input Current <sup>(2)</sup>   |                            | 30 mA                               |
| SMBDAT Output Sink Current   |                            | 10 mA                               |
| Junction Temperature <sup>(3)</sup>  |                            | +125°C                              |
| Storage Temperature  |                            | -65°C to +150°C                     |
| ESD Susceptibility <sup>(4)</sup>  | Human Body Model           | 2000 V                              |
|  | Machine Model              | 200 V                               |
|  | Charged Device Model Model | 1000 V                              |
| For soldering specifications, see <a href="http://www.ti.com/lit/SNOA549">http://www.ti.com/lit/SNOA549</a> . <sup>(5)</sup> |                            |                                     |

- (1) Absolute Maximum Ratings indicate limits beyond which damage to the device may occur. Operating Ratings indicate conditions for which the device is ensured to be functional, but do not ensure specific performance limits. For ensured specifications and test conditions, see the Electrical Characteristics. The ensured specifications apply only for the test conditions listed. Some performance characteristics may degrade when the device is not operated under the listed test conditions. Operation of the device beyond the maximum Operating Ratings is not recommended.
- (2) When the input voltage (V<sub>I</sub>) at any pin exceeds the power supplies (V<sub>I</sub> < GND or V<sub>I</sub> > V<sub>DD</sub>), the current at that pin should be limited to 5 mA. Parasitic components and or ESD protection circuitry are shown in [Figure 2](#) and [Table 1](#) for the LM95241's pins. Care should be taken not to forward bias the parasitic diode, D1, present on pins: D1+, D2+, D1-, D2-. Doing so by more than 50 mV may corrupt the temperature measurements.
- (3) Thermal resistance junction-to-ambient when attached to a printed circuit board with 1oz. foil and no air flow:  
— VSSOP-8 = 210°C/W
- (4) Human body model (HBM), 100pF discharged through a 1.5kΩ resistor. Machine model (MM), 200pF discharged directly into each pin. Charged Device Model (CDM) simulates a pin slowly acquiring charge (such as from a device sliding down the feeder in an automated assembler) then rapidly being discharged.
- (5) Reflow temperature profiles are different for packages containing lead (Pb) than for those that do not.

### Operating Ratings<sup>(1)(2)</sup>

|  |  |  |
|--|--|--|
| Operating Temperature Range                  |  | 0°C to +125°C  |
| Electrical Characteristics Temperature Range |  | T <sub>MIN</sub> ≤ T <sub>A</sub> ≤ T <sub>MAX</sub> |
| LM95241C1MM                                  |  | 0°C ≤ T <sub>A</sub> ≤ +85°C                         |
| Supply Voltage Range (V <sub>DD</sub> )      |  | +3.0V to +3.6V                                       |

- (1) Absolute Maximum Ratings indicate limits beyond which damage to the device may occur. Operating Ratings indicate conditions for which the device is ensured to be functional, but do not ensure specific performance limits. For ensured specifications and test conditions, see the Electrical Characteristics. The ensured specifications apply only for the test conditions listed. Some performance characteristics may degrade when the device is not operated under the listed test conditions. Operation of the device beyond the maximum Operating Ratings is not recommended.
- (2) Thermal resistance junction-to-ambient when attached to a printed circuit board with 1oz. foil and no air flow:  
— VSSOP-8 = 210°C/W

## Temperature-to-Digital Converter Characteristics

Unless otherwise noted, these specifications apply for  $V_{DD}=+3.0Vdc$  to  $3.6Vdc$ . **Boldface limits apply for  $T_A = T_J = T_{MIN} \leq T_A \leq T_{MAX}$** ; all other limits  $T_A = T_J = +25^\circ C$ , unless otherwise noted.  $T_J$  is the junction temperature of the LM95241.  $T_D$  is the junction temperature of the remote thermal diode.

| Parameter   | Conditions  | Typical <sup>(1)</sup> | Limits <sup>(2)</sup>        | Units (Limit)    |
|---|---|------------------------|------------------------------|------------------|
| Accuracy Using Local Diode  | $T_A = 0^\circ C$ to $+85^\circ C$ <sup>(3)</sup> | $\pm 1$                | <b><math>\pm 3</math></b>    | $^\circ C$ (max) |
| Accuracy Using Remote Diode, see <sup>(4)</sup> for Thermal Diode Processor Type. | $T_A = +20^\circ C$ to $+40^\circ C$              |                        | <b><math>\pm 1.25</math></b> | $^\circ C$ (max) |
|   | $T_A = +0^\circ C$ to $+85^\circ C$               |                        | <b><math>\pm 2.5</math></b>  | $^\circ C$ (max) |
| Remote Diode Measurement Resolution with filtering turned off                     |   | 10+sign/11             |                              | Bits             |
|   |   | 0.125                  |                              | $^\circ C$       |
| Remote Diode Measurement Resolution with digital filtering turned on              |   | 12+sign/13             |                              | Bits             |
|   |   | 0.03125                |                              | $^\circ C$       |
| Local Diode Measurement Resolution  |   | 9+sign                 |                              | Bits             |
|   |   | 0.25                   |                              | $^\circ C$       |
| Conversion Time of All Temperatures at the Fastest Setting <sup>(5)</sup>         | TruTherm Mode Disabled for All Remote Channels    | 76.5                   | <b>86.1</b>                  | ms (max)         |
|   | TruTherm Mode Enabled for All Remote Channels     | 79.1                   | <b>88.9</b>                  | ms (max)         |
| Average Quiescent Current <sup>(6)</sup>  | SMBus Inactive, 1 Hz conversion rate              | 471                    | <b>640</b>                   | $\mu A$ (max)    |
|   | Shutdown  | 356                    |                              | $\mu A$          |
| D- Source Voltage   |   | 0.4                    |                              | V                |
| Diode Source Current Ratio  |   | 16                     |                              |                  |
| Diode Source Current  | $(V_{D+} - V_{D-}) = +0.65V$ ; high-level         | 172                    | <b>230</b>                   | $\mu A$ (max)    |
|   |   |                        | <b>100</b>                   | $\mu A$ (min)    |
|   | Low-level   | 11                     |                              | $\mu A$          |
| Power-On Reset Threshold  | Measure on $V_{DD}$ input, falling edge           |                        | <b>2.7</b>                   | V (max)          |
|   |   |                        | <b>1.6</b>                   | V (min)          |

- (1) Typical figures are at  $T_A = 25^\circ C$  and represent most likely parametric norms at the time of product characterization. The typical specifications are not ensured.
- (2) Limits are specified to Texas Instruments' AOQL (Average Outgoing Quality Level).
- (3) Local temperature accuracy does not include the effects of self-heating. The rise in temperature due to self-heating is the product of the internal power dissipation of the LM95241 and the thermal resistance. See [Note 2](#) of the Operating Ratings table for the thermal resistance to be used in the self-heating calculation.
- (4) The accuracy of the LM95241C1MM is ensured when using a typical thermal diode of an Intel processor on a 65 nm process or an MMBT3904 diode-connected transistor, as selected in the Remote Diode Model Select register. See typical performance curve for performance with Intel processor on a 90nm process.
- (5) This specification is provided only to indicate how often temperature data is updated. The LM95241 can be read at any time without regard to conversion state (and will yield last conversion result).
- (6) Quiescent current will not increase substantially when the SMBus is active.

## Logic Electrical Characteristics Digital DC Characteristics

Unless otherwise noted, these specifications apply for  $V_{DD}=+3.0$  to  $3.6$  Vdc. **Boldface limits apply for  $T_A = T_J = T_{MIN}$  to  $T_{MAX}$** ; all other limits  $T_A = T_J = +25^\circ\text{C}$ , unless otherwise noted.

| Symbol                       | Parameter                                  | Conditions                                     | Typical <sup>(1)</sup> | Limits <sup>(2)</sup>      | Units (Limit)       |
|------------------------------|--|--|------------------------|----------------------------|---------------------|
| <b>SMBDAT, SMBCLK INPUTS</b> |  |  |                        |                            |                     |
| $V_{IN(1)}$                  | Logical "1" Input Voltage                  |  |                        | <b>2.1</b>                 | V (min)             |
| $V_{IN(0)}$                  | Logical "0" Input Voltage                  |  |                        | <b>0.8</b>                 | V (max)             |
| $V_{IN(HYST)}$               | SMBDAT and SMBCLK Digital Input Hysteresis |  | 400                    |                            | mV                  |
| $I_{IN(1)}$                  | Logical "1" Input Current                  | $V_{IN} = V_{DD}$                              | 0.005                  | <b><math>\pm 10</math></b> | $\mu\text{A}$ (max) |
| $I_{IN(0)}$                  | Logical "0" Input Current                  | $V_{IN} = 0$ V                                 | -0.005                 | <b><math>\pm 10</math></b> | $\mu\text{A}$ (max) |
| $C_{IN}$                     | Input Capacitance                          |  | 5                      |                            | pF                  |
| <b>SMBDAT OUTPUT</b>         |  |  |                        |                            |                     |
| $I_{OH}$                     | High Level Output Current                  | $V_{OH} = V_{DD}$                              |                        | <b>10</b>                  | $\mu\text{A}$ (max) |
| $V_{OL}$                     | SMBus Low Level Output Voltage             | $I_{OL} = 4\text{mA}$<br>$I_{OL} = 6\text{mA}$ |                        | <b>0.4</b><br><b>0.6</b>   | V (max)             |

(1) Typical figures are at  $T_A = 25^\circ\text{C}$  and represent most likely parametric norms at the time of product characterization. The typical specifications are not ensured.

(2) Limits are specified to Texas Instruments' AOQL (Average Outgoing Quality Level).

## Logic Electrical Characteristics SMBus Digital Switching Characteristics

Unless otherwise noted, these specifications apply for  $V_{DD}=+3.0$  Vdc to  $+3.6$  Vdc,  $C_L$  (load capacitance) on output lines =  $80$  pF. **Boldface limits apply for  $T_A = T_J = T_{MIN}$  to  $T_{MAX}$** ; all other limits  $T_A = T_J = +25^\circ\text{C}$ , unless otherwise noted.

The switching characteristics of the LM95241 fully meet or exceed the published specifications of the SMBus version 2.0. The following parameters are the timing relationships between SMBCLK and SMBDAT signals related to the LM95241. They adhere to but are not necessarily the SMBus bus specifications.

| Symbol        | Parameter   | Conditions  | Typical <sup>(1)</sup> | Limits <sup>(2)</sup>     | Units (Limit)                   |
|---------------|---|---|------------------------|---------------------------|---------------------------------|
| $f_{SMB}$     | SMBus Clock Frequency   |   |                        | <b>100</b><br><b>10</b>   | kHz (max)<br>kHz (min)          |
| $t_{LOW}$     | SMBus Clock Low Time  | from $V_{IN(0)max}$ to $V_{IN(0)min}$                       |                        | <b>4.7</b><br><b>25</b>   | $\mu\text{s}$ (min)<br>ms (max) |
| $t_{HIGH}$    | SMBus Clock High Time   | from $V_{IN(1)min}$ to $V_{IN(1)min}$                       |                        | <b>4.0</b>                | $\mu\text{s}$ (min)             |
| $t_{R,SMB}$   | SMBus Rise Time   | See <sup>(3)</sup>  | 1                      |                           | $\mu\text{s}$ (max)             |
| $t_{F,SMB}$   | SMBus Fall Time   | See <sup>(4)</sup>  | 0.3                    |                           | $\mu\text{s}$ (max)             |
| $t_{OF}$      | Output Fall Time  | $C_L = 400\text{pF}$ ,<br>$I_O = 3\text{mA}$ <sup>(4)</sup> |                        | <b>250</b>                | ns (max)                        |
| $t_{TIMEOUT}$ | SMBDAT and SMBCLK Time Low for Reset of Serial Interface <sup>(5)</sup>                             |   |                        | <b>25</b><br><b>35</b>    | ms (min)<br>ms (max)            |
| $t_{SU,DAT}$  | Data In Setup Time to SMBCLK High   |   |                        | <b>250</b>                | ns (min)                        |
| $t_{HD,DAT}$  | Data Out Stable after SMBCLK Low  |   |                        | <b>300</b><br><b>1075</b> | ns (min)<br>ns (max)            |
| $t_{HD,STA}$  | Start Condition SMBDAT Low to SMBCLK Low (Start condition hold before the first clock falling edge) |   |                        | <b>100</b>                | ns (min)                        |
| $t_{SU,STO}$  | Stop Condition SMBCLK High to SMBDAT Low (Stop Condition Setup)                                     |   |                        | <b>100</b>                | ns (min)                        |
| $t_{SU,STA}$  | SMBus Repeated Start-Condition Setup Time, SMBCLK High to SMBDAT Low                                |   |                        | <b>0.6</b>                | $\mu\text{s}$ (min)             |

(1) Typical figures are at  $T_A = 25^\circ\text{C}$  and represent most likely parametric norms at the time of product characterization. The typical specifications are not ensured.

(2) Limits are specified to Texas Instruments' AOQL (Average Outgoing Quality Level).

(3) The output rise time is measured from  $(V_{IN(0)max} + 0.15\text{V})$  to  $(V_{IN(1)min} - 0.15\text{V})$ .

(4) The output fall time is measured from  $(V_{IN(1)min} - 0.15\text{V})$  to  $(V_{IN(1)min} + 0.15\text{V})$ .

(5) Holding the SMBDAT and/or SMBCLK lines Low for a time interval greater than  $t_{TIMEOUT}$  will reset the LM95241's SMBus state machine, therefore setting SMBDAT and SMBCLK pins to a high impedance state.

### Logic Electrical Characteristics SMBus Digital Switching Characteristics (continued)

Unless otherwise noted, these specifications apply for  $V_{DD}=+3.0$  Vdc to  $+3.6$  Vdc,  $C_L$  (load capacitance) on output lines = 80 pF. **Boldface limits apply for  $T_A = T_J = T_{MIN}$  to  $T_{MAX}$** ; all other limits  $T_A = T_J = +25^\circ\text{C}$ , unless otherwise noted.

The switching characteristics of the LM95241 fully meet or exceed the published specifications of the SMBus version 2.0. The following parameters are the timing relationships between SMBCLK and SMBDAT signals related to the LM95241. They adhere to but are not necessarily the SMBus bus specifications.

| Symbol    | Parameter   | Conditions | Typical <sup>(1)</sup> | Limits <sup>(2)</sup> | Units (Limit)       |
|-----------|---|------------|------------------------|-----------------------|---------------------|
| $t_{BUF}$ | SMBus Free Time Between Stop and Start Conditions |            |                        | <b>1.3</b>            | $\mu\text{s}$ (min) |

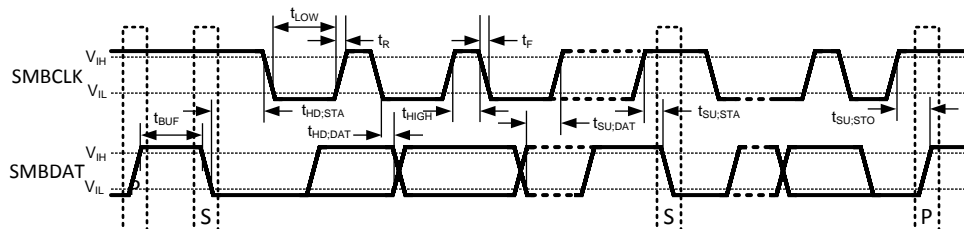

Figure 2. SMBus Communication

Table 1. Parasitic components and ESD protection circuitry

| Pin # | Label    | Circuit | All Input ESD Protection Structure Circuits |  |
|-------|----------|---------|---|--|
| 1     | D1+      | A       |   |  |
| 2     | D1-      | A       |   |  |
| 3     | D2+      | A       |   |  |
| 4     | D2-      | A       |   |  |
| 5     | GND      | B       |   |  |
| 6     | $V_{DD}$ | B       |   |  |
| 7     | SMBDAT   | C       |   |  |
| 8     | SMBCLK   | C       |   |  |

**Typical Performance Characteristics**

**Intel Processor on 65nm Process or 90nm Process Thermal Diode Performance Comparison**

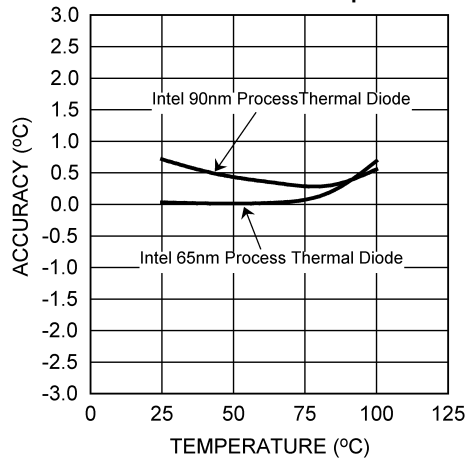

**Figure 3.**

**Thermal Diode Capacitor or PCB Leakage Current Effect Remote Diode Temperature Reading**

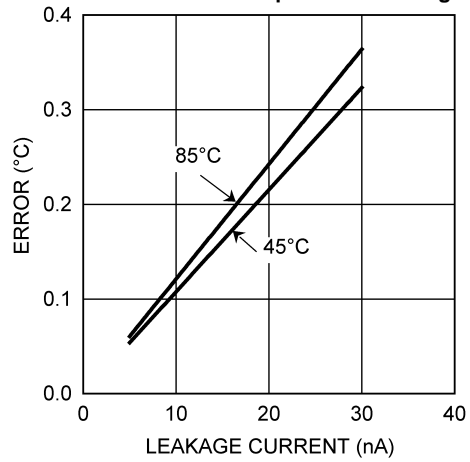

**Figure 4.**

**Remote Temperature Reading Sensitivity to Thermal Diode Filter Capacitance**

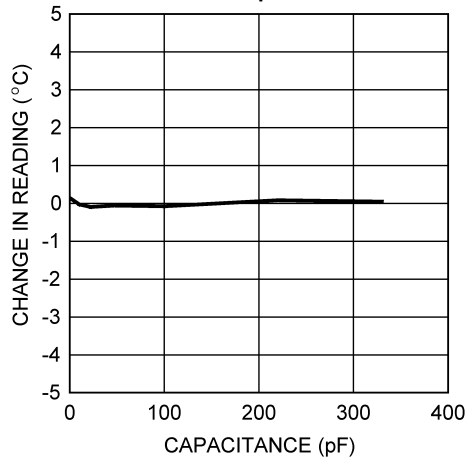

**Figure 5.**

**Conversion Rate Effect on Average Power Supply Current**

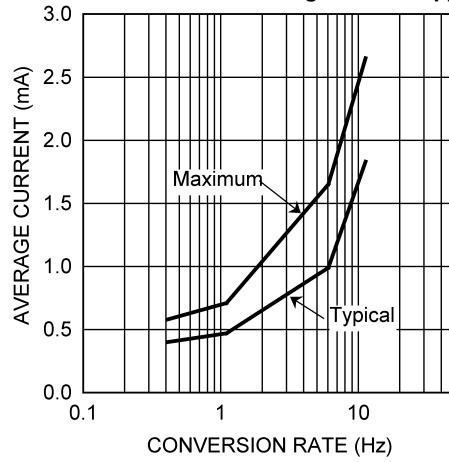

**Figure 6.**

## FUNCTIONAL DESCRIPTION

The LM95241 is a digital sensor that can sense the temperature of 3 thermal zones using a sigma-delta analog-to-digital converter. It can measure its local die temperature and the temperature of two external transistor junctions using a  $\Delta V_{be}$  temperature sensing method. The LM95241 can support two external transistor types, a Intel processor on 65nm or 90nm process thermal diode or a 2N3904 diode connected transistor. The transistor type is register programmable and does not require software intervention after initialization. The LM95241 has an advanced input stage using Texas Instruments' TruTherm technology that reduces the spread in non-ideality found in Intel processors on 65nm or 90nm process. Internal analog filtering has been included in the thermal diode input stage thus minimizing the need for external thermal diode filter capacitors. In addition a digital filter has been added. These noise immunity improvements in the analog input stage along with the digital filtering will allow longer trace tracks or cabling to the thermal diode than previous thermal diode sensor devices.

The 2-wire serial interface, of the LM95241, is compatible with SMBus 2.0 and I2C. Please see the SMBus 2.0 specification for a detailed description of the differences between the I2C bus and SMBus.

The temperature conversion rate is programmable to allow the user to optimize the current consumption of the LM95241 to the system requirements. The LM95241 can be placed in shutdown to minimize power consumption when temperature data is not required. While in shutdown, a 1-shot conversion mode allows system control of the conversion rate for ultimate flexibility.

The remote diode temperature resolution is variable and depends on whether the digital filter is activated. When the digital filter is active the resolution is thirteen bits and is programmable to 13-bits unsigned or 12-bits plus sign, with a least-significant-bit (LSb) weight for both resolutions of 0.03125°C. When the digital filter is inactive the resolution is eleven bits and is programmable to 11-bits unsigned or 10-bits plus sign, with a least-significant-bit (LSb) weight for both resolutions of 0.125°C. The unsigned resolution allows the remote diodes to sense temperatures above 127°C. Local temperature resolution is not programmable and is always 9-bits plus sign and has a 0.25°C LSb.

The LM95241 remote diode temperature accuracy is trimmed for the typical thermal diode of a Intel processor on 65nm or 90nm process or a typical 2N3904 transistor and the accuracy is ensured only when using either of these diodes when selected appropriately. TruTherm mode should be enabled when measuring a Intel processor on 65nm or 90nm process and disabled when measuring a 3904 transistor.

Diode fault detection circuitry in the LM95241 can detect the presence of a remote diode.

The LM95241 register set has an 8-bit data structure and includes:

1. Most-Significant-Byte (MSB) Local Temperature Register
2. Least-Significant-Byte (LSB) Local Temperature Register
3. MSB Remote Temperature 1 Register
4. LSB Remote Temperature 1 Register
5. MSB Remote Temperature 2 Register
6. LSB Remote Temperature 2 Register
7. Status Register: busy, diode fault
8. Configuration Register: resolution control, conversion rate control, standby control
9. Remote Diode Filter Setting
10. Remote Diode Model Select
11. Remote Diode TruTherm Mode Control
12. 1-shot Register
13. Manufacturer ID
14. Revision ID

## CONVERSION SEQUENCE

In the power up default state the LM95241 typically takes 77.8 ms to convert the Local Temperature, Remote Temperature 1 and 2, and to update all of its registers. Only during the conversion process is the busy bit (D7) in the Status register (02h) high. These conversions are addressed in a round robin sequence. The conversion rate may be modified by the Conversion Rate bits found in the Configuration Register (03h). When the conversion rate is modified a delay is inserted between conversions, the actual maximum conversion time remains at 88.9 ms. Different conversion rates will cause the LM95241 to draw different amounts of supply current as shown in Figure 7.

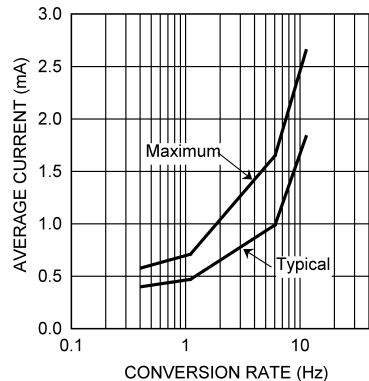

Figure 7. Conversion Rate Effect on Power Supply Current

## POWER-ON-DEFAULT STATES

LM95241 always powers up to these known default states. The LM95241 remains in these states until after the first conversion.

1. Command Register set to 00h
2. Local Temperature set to 0°C until the end of the first conversion
3. Remote Diode Temperature set to 0°C until the end of the first conversion
4. Remote Diode digital filters are on.
5. Remote Diode 1 model is set to Intel processor on 65nm or 90nm process with TruTherm Mode enabled. Remote Diode 2 model is set to 2N3904/MMBT3904 with TruTherm mode disabled.
6. Status Register depends on state of thermal diode inputs
7. Configuration register set to 00h; continuous conversion

## SMBus INTERFACE

The LM95241 operates as a slave on the SMBus, so the SMBCLK line is an input and the SMBDAT line is bidirectional. The LM95241 never drives the SMBCLK line and it does not support clock stretching. According to SMBus specifications, the LM95241 has a 7-bit slave address. All bits A6 through A0 are internally programmed and cannot be changed by software or hardware. The SMBus slave address is dependent on the LM95241 part number ordered:

| Version       | A6 | A5 | A4 | A3 | A2 | A1 | A0 |
|---------------|----|----|----|----|----|----|----|
| LM95241C1MM   | 0  | 1  | 0  | 1  | 0  | 1  | 1  |
| LM95241C1MM-1 | 0  | 0  | 1  | 1  | 0  | 0  | 1  |
| LM95241C1MM-2 | 0  | 1  | 0  | 1  | 0  | 1  | 0  |

## TEMPERATURE DATA FORMAT

Temperature data can only be read from the Local and Remote Temperature registers .

Remote temperature data with the digital filter off is represented by an 11-bit, two's complement word or unsigned binary word with an LSb (Least Significant Bit) equal to 0.125°C. The data format is a left justified 16-bit word available in two 8-bit registers. Unused bits will always report "0".

**Table 2. 11-bit, 2's complement (10-bit plus sign)**

| Temperature | Digital Output      |       |
|-------------|---------------------|-------|
|             | Binary              | Hex   |
| +125°C      | 0111 1101 0000 0000 | 7D00h |
| +25°C       | 0001 1001 0000 0000 | 1900h |
| +1°C        | 0000 0001 0000 0000 | 0100h |
| +0.125°C    | 0000 0000 0010 0000 | 0020h |
| 0°C         | 0000 0000 0000 0000 | 0000h |
| -0.125°C    | 1111 1111 1110 0000 | FFE0h |
| -1°C        | 1111 1111 0000 0000 | FF00h |
| -25°C       | 1110 0111 0000 0000 | E700h |
| -55°C       | 1100 1001 0000 0000 | C900h |

**Table 3. 11-bit, unsigned binary**

| Temperature | Digital Output      |       |
|-------------|---------------------|-------|
|             | Binary              | Hex   |
| +255.875°C  | 1111 1111 1110 0000 | FFE0h |
| +255°C      | 1111 1111 0000 0000 | FF00h |
| +201°C      | 1100 1001 0000 0000 | C900h |
| +125°C      | 0111 1101 0000 0000 | 7D00h |
| +25°C       | 0001 1001 0000 0000 | 1900h |
| +1°C        | 0000 0001 0000 0000 | 0100h |
| +0.125°C    | 0000 0000 0010 0000 | 0020h |
| 0°C         | 0000 0000 0000 0000 | 0000h |

Remote temperature data with the digital filter on is represented by a 13-bit, two's complement word or unsigned binary word with an LSb (Least Significant Bit) equal to 0.03125°C (1/32°C). The data format is a left justified 16-bit word available in two 8-bit registers. Unused bits will always report "0".

**Table 4. 13-bit, 2's complement**

| Temperature | Digital Output      |       |
|-------------|---------------------|-------|
|             | Binary              | Hex   |
| +125°C      | 0111 1101 0000 0000 | 7D00h |
| +25°C       | 0001 1001 0000 0000 | 1900h |
| +1°C        | 0000 0001 0000 0000 | 0100h |
| +0.03125°C  | 0000 0000 0000 1000 | 0008h |
| 0°C         | 0000 0000 0000 0000 | 0000h |
| -0.03125°C  | 1111 1111 1111 0111 | FFF7h |
| -1°C        | 1111 1111 0000 0000 | FF00h |
| -25°C       | 1110 0111 0000 0000 | E700h |
| -55°C       | 1100 1001 0000 0000 | C900h |

**Table 5. 13-bit, unsigned binary**

| Temperature | Digital Output      |       |
|-------------|---------------------|-------|
|             | Binary              | Hex   |
| +255.875°C  | 1111 1111 1110 0000 | FFE0h |
| +255°C      | 1111 1111 0000 0000 | FF00h |
| +201°C      | 1100 1001 0000 0000 | C900h |
| +125°C      | 0111 1101 0000 0000 | 7D00h |
| +25°C       | 0001 1001 0000 0000 | 1900h |
| +1°C        | 0000 0001 0000 0000 | 0100h |
| +0.03125°C  | 0000 0000 0000 1000 | 0008h |
| 0°C         | 0000 0000 0000 0000 | 0000h |

Local Temperature data is represented by a 10-bit, two's complement word with an LSb (Least Significant Bit) equal to 0.25°C. The data format is a left justified 16-bit word available in two 8-bit registers. Unused bits will always report "0". Local temperature readings greater than +127.75°C are clamped to +127.75°C, they will not roll-over to negative temperature readings.

| Temperature | Digital Output      |       |
|-------------|---------------------|-------|
|             | Binary              | Hex   |
| +125°C      | 0111 1101 0000 0000 | 7D00h |
| +25°C       | 0001 1001 0000 0000 | 1900h |
| +1°C        | 0000 0001 0000 0000 | 0100h |
| +0.25°C     | 0000 0000 0100 0000 | 0040h |
| 0°C         | 0000 0000 0000 0000 | 0000h |
| -0.25°C     | 1111 1111 1100 0000 | FFC0h |
| -1°C        | 1111 1111 0000 0000 | FF00h |
| -25°C       | 1110 0111 0000 0000 | E700h |
| -55°C       | 1100 1001 0000 0000 | C900h |

## SMBDAT OPEN-DRAIN OUTPUT

The SMBDAT output is an open-drain output and does not have internal pull-ups. A "high" level will not be observed on this pin until pull-up current is provided by some external source, typically a pull-up resistor. Choice of resistor value depends on many system factors but, in general, the pull-up resistor should be as large as possible without effecting the SMBus desired data rate. This will minimize any internal temperature reading errors due to internal heating of the LM95241. The maximum resistance of the pull-up to provide a 2.1V high level, based on LM95241 specification for High Level Output Current with the supply voltage at 3.0V, is 82kΩ(5%) or 88.7kΩ(1%).

## DIODE FAULT DETECTION

The LM95241 is equipped with operational circuitry designed to detect fault conditions concerning the remote diodes. In the event that the D+ pin is detected as shorted to GND, D-, V<sub>DD</sub> or D+ is floating, the Remote Temperature reading is -128.000 °C if signed format is selected and +255.875 if unsigned format is selected. In addition, the appropriate status register bits RD1M or RD2M (D1 or D0) are set.

## COMMUNICATING WITH THE LM95241

The data registers in the LM95241 are selected by the Command Register. At power-up the Command Register is set to "00", the location for the Read Local Temperature Register. The Command Register latches the last location it was set to. Each data register in the LM95241 falls into one of four types of user accessibility:

1. Read only
2. Write only
3. Write/Read same address
4. Write/Read different address

A **Write** to the LM95241 will always include the address byte and the command byte. A write to any register requires one data byte.

**Reading** the LM95241 can take place either of two ways:

1. If the location latched in the Command Register is correct (most of the time it is expected that the Command Register will point to one of the Read Temperature Registers because that will be the data most frequently read from the LM95241), then the read can simply consist of an address byte, followed by retrieving the data byte.
2. If the Command Register needs to be set, then an address byte, command byte, repeat start, and another address byte will accomplish a read.

The data byte has the most significant bit first. At the end of a read, the LM95241 can accept either acknowledge or No Acknowledge from the Master (No Acknowledge is typically used as a signal for the slave that the Master has read its last byte). When retrieving all 11 bits from a previous remote diode temperature measurement, the master must insure that all 11 bits are from the same temperature conversion. This may be achieved by reading the MSB register first. The LSB will be locked after the MSB is read. The LSB will be unlocked after being read. If the user reads MSBs consecutively, each time the MSB is read, the LSB associated with that temperature will be locked in and override the previous LSB value locked-in.

### SMBus Timing Diagrams for Access of Data

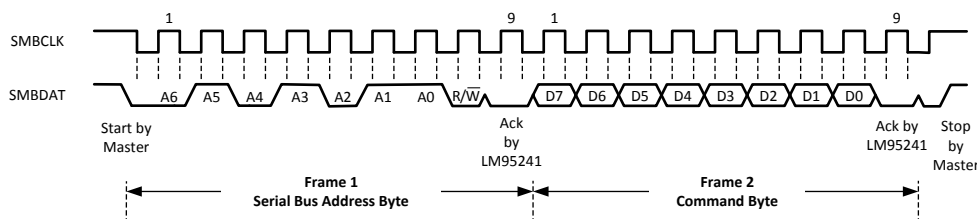

Figure 8. Serial Bus Write to the Internal Command Register

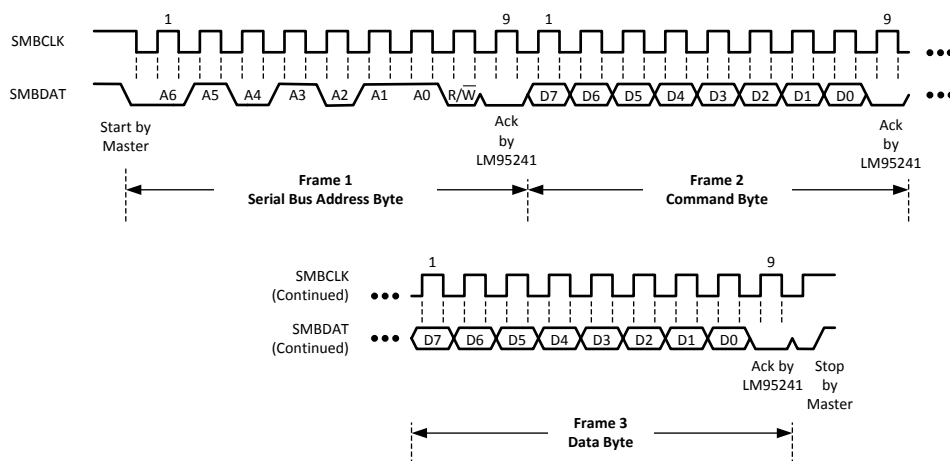
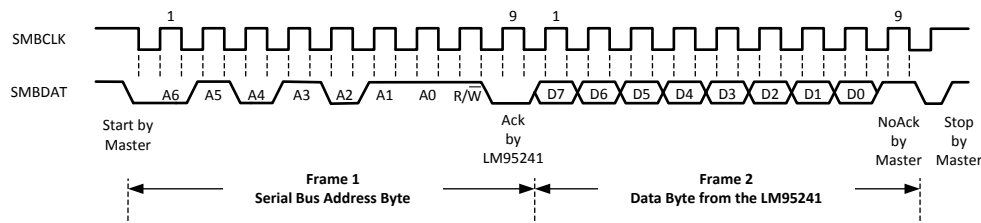
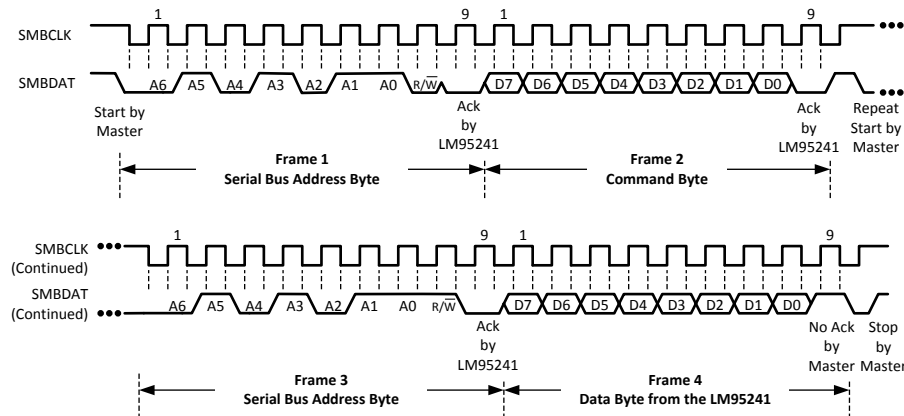

Figure 9. Serial Bus Write to the internal Command Register followed by a Data Byte



**Figure 10. Serial Bus byte Read from a Register with the internal Command Register preset to desired value.**



**Figure 11. Serial Bus Write followed by a Repeat Start and Immediate Read**

## SERIAL INTERFACE RESET

In the event that the SMBus Master is RESET while the LM95241 is transmitting on the SMBDAT line, the LM95241 must be returned to a known state in the communication protocol. This may be done in one of two ways:

1. When SMBDAT is LOW, the LM95241 SMBus state machine resets to the SMBus idle state if either SMBDAT or SMBCLK are held low for more than 35ms ( $t_{TIMEOUT}$ ). Note that according to SMBus specification 2.0 all devices are to timeout when either the SMBCLK or SMBDAT lines are held low for 25-35ms. Therefore, to insure a timeout of all devices on the bus the SMBCLK or SMBDAT lines must be held low for at least 35ms.
2. When SMBDAT is HIGH, have the master initiate an SMBus start. The LM95241 will respond properly to an SMBus start condition at any point during the communication. After the start the LM95241 will expect an SMBus Address address byte.

## ONE-SHOT CONVERSION

The One-Shot register is used to initiate a single conversion and comparison cycle when the device is in standby mode, after which the device returns to standby. This is not a data register and it is the write operation that causes the one-shot conversion. The data written to this address is irrelevant and is not stored. A zero will always be read from this register.

## LM95241 Registers

Command register selects which registers will be read from or written to. Data for this register should be transmitted during the Command Byte of the SMBus write communication.

|         |    |    |    |    |    |    |    |
|---------|----|----|----|----|----|----|----|
| P7      | P6 | P5 | P4 | P3 | P2 | P1 | P0 |
| Command |    |    |    |    |    |    |    |

P0-P7: Command

**Table 6. Register Summary**

| Name                               | Command (Hex) | Power-On Default Value (Hex) | Read/Write | # of used bits | Comments  |
|------------------------------------|---------------|------------------------------|------------|----------------|---|
| Status Register                    | 02h           | -                            | RO         | 5              | 4 status bits and 1 busy bit  |
| Configuration Register             | 03h           | 00h                          | R/W        | 5              | Includes conversion rate control  |
| Remote Diode Filter Control        | 06h           | 05h                          | R/W        | 2              | Controls thermal diode filter setting   |
| Remote Diode Model Type Select     | 30h           | 01h                          | R/W        | 2              | Selects the 2N3904 or Intel processor on 65nm or 90nm process thermal diode model   |
| Remote Diode TruTherm Mode Control | 07h           | 01h                          |            | 6              | Enables or disables TruTherm technology for Remote Diode measurements   |
| 1-shot                             | 0Fh           | -                            | WO         | -              | Activates one conversion for all 3 channels if the chip is in standby mode (i.e. RUN/STOP bit = 1). Data transmitted by the host is ignored by the LM95241. |
| Local Temperature MSB              | 10h           | -                            | RO         | 8              |   |
| Remote Temperature 1 MSB           | 11h           | -                            | RO         | 8              |   |
| Remote Temperature 2 MSB           | 12h           | -                            | RO         | 8              |   |
| Local Temperature LSB              | 20h           | -                            | RO         | 2              | All unused bits will report zero  |
| Remote Temperature 1 LSB           | 21h           | -                            | RO         | 3/5            | All unused bits will report zero  |
| Remote Temperature 2 LSB           | 22h           | -                            | RO         | 3/5            | All unused bits will report zero  |
| Manufacturer ID                    | FEh           | 01h                          | RO         |                |   |
| Revision ID                        | FFh           | A4h                          | RO         |                |   |

## STATUS REGISTER

(Read Only Address 02h):

| D7   | D6       | D5 | D4 | D3    | D2    | D1   | D0   |
|------|----------|----|----|-------|-------|------|------|
| Busy | Reserved |    |    | R2TME | R1TME | RD2M | RD1M |
|      | 0        | 0  | 0  |       |       |      |      |

| Bits | Name                                   | Description  |
|------|--|--|
| 7    | Busy                                   | When set to "1" the part is converting.  |
| 6-4  | Reserved                               | Reports "0" when read.   |
| 3    | Remote 2 TruTherm Mode Enabled (R2TME) | When set to "1" indicates that the TruTherm Mode has been activated for Remote diode 2. After being enabled TruTherm Mode will take at most one conversion cycle to be fully active. This bit will be set even if the diode is disconnected.   |
| 2    | Remote 1 TruTherm Mode Enabled (R1TME) | When set to "1" indicates that the TruTherm Mode has been activated for Remote diode 1. After being enabled TruTherm Mode will take at most one conversion cycle to be fully active. This bit will be set even if the diode is disconnected.   |
| 1    | Remote Diode 2 Missing (RD2M)          | When set to "1" Remote Diode 2 is missing. (See <a href="#">DIODE FAULT DETECTION</a> for further details.) Temperature Reading is FFE0h which converts to 255.875 °C if unsigned format is selected or 8000h which converts to -128.000 °C if signed format is selected. Note, connecting a 3904 transistor to Remote 2 inputs with TruTherm mode active may also cause this bit to be set. |

| Bits | Name                          | Description  |
|------|-------------------------------|--|
| 0    | Remote Diode 1 Missing (RD1M) | When set to "1" Remote Diode 1 is missing. (See <a href="#">DIODE FAULT DETECTION</a> for further details.) Temperature Reading is FFE0h which converts to 255.875 °C if unsigned format is selected or 8000h which converts to –128.000 °C if signed format is selected. Note, connecting a 3904 transistor to Remote 1 inputs with TruTherm mode active may also cause this bit to be set. |

### CONFIGURATION REGISTER

(Read Address 03h /Write Address 03h):

| D7 | D6       | D5  | D4  | D3 | D2   | D1   | D0 |
|----|----------|-----|-----|----|------|------|----|
| 0  | RUN/STOP | CR1 | CR0 | 0  | R2DF | R1DF | 0  |

| Bits | Name                        | Description  |
|------|-----------------------------|--|
| 7    | Reserved                    | Reports "0" when read.   |
| 6    | RUN/STOP                    | Logic 1 disables the conversion and puts the part in standby mode. Conversion can be activated by writing to one-shot register.  |
| 5-4  | Conversion Rate (CR1:CR0)   | 00: continuous mode 76.5 ms, 13.1 Hz (typ), when TruTherm Mode is disabled (Diode Equation) for both remote channels; 77.8 ms, 12.9 Hz (typ), when TruTherm Mode is enabled (Transistor Equation) for one remote channel.<br>01: converts every 182 ms, 5.5 Hz (typ)<br>10: converts every 1 second, 1 Hz (typ)<br>11: converts every 2.7 seconds, 0.37 Hz (typ) |
| 3    | Reserved                    | Reports "0" when read.   |
| 2    | Remote 2 Data Format (R2DF) | Logic 0: unsigned Temperature format (0 °C to +255.875 °C)<br>Logic 1: signed Temperature format (-128 °C to +127.75 °C)   |
| 1    | Remote 1 Data Format (R1DF) | Logic 0: unsigned Temperature format (0 °C to +255.875 °C)<br>Logic 1: signed Temperature format (-128 °C to +127.75 °C)   |
| 0    | Reserved                    | Reports "0" when read.   |

Power up default is with all bits "0" (zero)

### REMOTE DIODE FILTER CONTROL REGISTER

(Read/write Address 06h):

| D7 | D6 | D5 | D4 | D3 | D2   | D1 | D0   |
|----|----|----|----|----|------|----|------|
| 0  | 0  | 0  | 0  | 0  | R2FE | 0  | R1FE |

| Bits | Name                          | Description                         |
|------|-------------------------------|-------------------------------------|
| 7-3  | Reserved                      | Reports "0" when read.              |
| 2    | Remote 2 Filter Enable (R2FE) | 0: Filter Off<br>1: Noise Filter On |
| 1    | Reserved                      | Reports "0" when read.              |
| 0    | Remote 1 Filter Enable (R1FE) | 0: Filter Off<br>1: Noise Filter On |

Power up default is 05h.

### REMOTE DIODE MODEL TYPE SELECT REGISTER

(Read/Write Address 30h):

| D7 | D6 | D5 | D4 | D3 | D2   | D1 | D0   |
|----|----|----|----|----|------|----|------|
| 0  | 0  | 0  | 0  | 0  | R2MS | 0  | R1MS |

| Bits | Name                               | Description  |
|------|------------------------------------|--|
| 7-3  | Reserved                           | Reports "0" when read.   |
| 2    | Remote Diode 2 Model Select (R2MS) | 0: 2N3904 model (make sure TruTherm mode is disabled)<br>1: Intel processor on 65nm or 90nm process model (make sure TruTherm mode is enabled)<br>Power up default is 0. |
| 1    | Reserved                           | Reports "0" when read.   |
| 0    | Remote Diode 1 Model Select (R1MS) | 0: 2N3904 model (make sure TruTherm mode is disabled)<br>1: Intel processor on 65nm or 90nm process model (make sure TruTherm mode is enabled)<br>Power up default is 1. |

Power up default is 01h.

### REMOTE DIODE TruTherm MODE CONTROL

(Read/Write Address 07h):

| D7       | D6   | D5   | D4   | D3       | D2   | D1   | D0   |
|----------|------|------|------|----------|------|------|------|
| Reserved | R2M2 | R2M1 | R2M0 | Reserved | R1M2 | R1M1 | R1M0 |

| Bits | Description |   |
|------|-------------|---|
| 7    | Reserved    | Must be left at 0.  |
| 6-4  | R2M2:R2M0   | 000: Remote 2 TruTherm Mode disabled; used when measuring MMBT3904 transistors<br>001: Remote 2 TruTherm Mode enabled; used when measuring Processors<br>111: Remote 2 TruTherm Mode enabled; used when measuring Processors<br>Note, all other codes provide unspecified results and should not be used. |
| 3    | Reserved    | Must be left at 0.  |
| 2-0  | R1M2:R1M0   | 000: Remote 1 TruTherm Mode disabled; used when measuring MMBT3904 transistors<br>001: Remote 1 TruTherm Mode enabled; used when measuring Processors<br>111: Remote 1 TruTherm Mode enabled; used when measuring Processors<br>Note, all other codes provide unspecified results and should not be used. |

Power up default is 01h.

### LOCAL AND REMOTE MSB AND LSB TEMPERATURE REGISTERS

#### Local Temperature MSB

(Read Only Address 10h) 9-bit plus sign format:

| BIT   | D7   | D6 | D5 | D4 | D3 | D2 | D1 | D0 |
|-------|------|----|----|----|----|----|----|----|
| Value | SIGN | 64 | 32 | 16 | 8  | 4  | 2  | 1  |

Temperature Data: LSb = 1°C.

#### Local Temperature LSB

(Read Only Address 20h) 9-bit plus sign format:

| BIT   | D7  | D6   | D5 | D4 | D3 | D2 | D1 | D0 |
|-------|-----|------|----|----|----|----|----|----|
| Value | 0.5 | 0.25 | 0  | 0  | 0  | 0  | 0  | 0  |

Temperature Data: LSb = 0.25°C.

**Remote Temperature MSB**

(Read Only Address 11h, 12h) 10-bit plus sign format:

| BIT   | D7   | D6 | D5 | D4 | D3 | D2 | D1 | D0 |
|-------|------|----|----|----|----|----|----|----|
| Value | SIGN | 64 | 32 | 16 | 8  | 4  | 2  | 1  |

Temperature Data: LSb = 1°C.

**Remote Temperature MSB**

(Read Only Address 11h, 12h) 11-bit plus sign format:

| BIT   | D7  | D6 | D5 | D4 | D3 | D2 | D1 | D0 |
|-------|-----|----|----|----|----|----|----|----|
| Value | 128 | 64 | 32 | 16 | 8  | 4  | 2  | 1  |

Temperature Data: LSb = 1°C.

**Remote Temperature LSB**

(Read Only Address 21, 22h) 10-bit plus sign or 11-bit unsigned binary formats with filter off:

| BIT   | D7  | D6   | D5    | D4 | D3 | D2 | D1 | D0 |
|-------|-----|------|-------|----|----|----|----|----|
| Value | 0.5 | 0.25 | 0.125 | 0  | 0  | 0  | 0  | 0  |

Temperature Data: LSb = 0.125°C or 1/8°C.

**Remote Temperature LSB**

12-bit plus sign or 13-bit unsigned binary formats with filter on:

| BIT   | D7  | D6   | D5    | D4     | D3      | D2 | D1 | D0 |
|-------|-----|------|-------|--------|---------|----|----|----|
| Value | 0.5 | 0.25 | 0.125 | 0.0625 | 0.03125 | 0  | 0  | 0  |

Temperature Data: LSb = 0.03125°C or 1/32°C.

For data synchronization purposes, the MSB register should be read first if the user wants to read both MSB and LSB registers. The LSB will be locked after the MSB is read. The LSB will be unlocked after being read. If the user reads MSBs consecutively, each time the MSB is read, the LSB associated with that temperature will be locked in and override the previous LSB value locked-in.

**MANUFACTURERS ID REGISTER**

(Read Address FEh) The default value is 01h.

**DIE REVISION CODE REGISTER**

(Read Address FFh) The default value is A4h. This register will increment by 1 every time there is a revision to the die by Texas Instruments.

**Applications Hints**

The LM95241 can be applied easily in the same way as other integrated-circuit temperature sensors, and its remote diode sensing capability allows it to be used in new ways as well. It can be soldered to a printed circuit board, and because the path of best thermal conductivity is between the die and the pins, its temperature will effectively be that of the printed circuit board lands and traces soldered to the LM95241's pins. This presumes that the ambient air temperature is almost the same as the surface temperature of the printed circuit board; if the air temperature is much higher or lower than the surface temperature, the actual temperature of the LM95241 die will be at an intermediate temperature between the surface and air temperatures. Again, the primary thermal conduction path is through the leads, so the circuit board temperature will contribute to the die temperature much more strongly than will the air temperature.

To measure temperature external to the LM95241's die, use a remote diode. This diode can be located on the die of a target IC, allowing measurement of the IC's temperature, independent of the LM95241's temperature. A discrete diode can also be used to sense the temperature of external objects or ambient air. Remember that a discrete diode's temperature will be affected, and often dominated, by the temperature of its leads. Most silicon diodes do not lend themselves well to this application. It is recommended that a 2N3904 transistor base emitter junction be used with the collector tied to the base.

The LM95241's TruTherm technology allows accurate sensing of integrated thermal diodes, such as those found on sub-micron geometry processors. With TruTherm technology turned off, the LM95241 can measure a diode connected transistor such as the 2N3904 or MMBT3904.

The LM95241 has been optimized to measure the remote thermal diode integrated in a Intel processor on 65nm or 90nm process or an MMBT3904 transistor. Using the Remote Diode Model Select register either pair of remote inputs can be assigned to measure either a Intel processor on 65nm or 90nm process or an MMBT3904 transistor.

## DIODE NON-IDEALITY

### *Diode Non-Ideality Factor Effect on Accuracy*

When a transistor is connected as a diode, the following relationship holds for variables  $V_{BE}$ ,  $T$  and  $I_F$ :

$$I_F = I_S \times \left[ e^{\left( \frac{V_{BE}}{\eta \times V_t} \right)} - 1 \right]$$

where

- $V_t = \frac{kT}{q}$
- $q = 1.6 \times 10^{-19}$  Coulombs (the electron charge)
- $T$  = Absolute Temperature in Kelvin
- $k = 1.38 \times 10^{-23}$  joules/K (Boltzmann's constant)
- $\eta$  is the non-ideality factor of the process the diode is manufactured on
- $I_S$  = Saturation Current and is process dependent
- $I_F$  = Forward Current through the base emitter junction
- $V_{BE}$  = Base Emitter Voltage drop

In the active region, the -1 term is negligible and may be eliminated, yielding the following equation

$$I_F = I_S \left[ e^{\eta V_t} \right] \tag{2}$$

In [Equation 2](#),  $\eta$  and  $I_S$  are dependant upon the process that was used in the fabrication of the particular diode. By forcing two currents with a very controlled ratio ( $I_{F2}/I_{F1}$ ) and measuring the resulting voltage difference, it is possible to eliminate the  $I_S$  term. Solving for the forward voltage difference yields the relationship:

$$\Delta V_{BE} = \eta \times \frac{k \times T}{q} \times \ln \left( \frac{I_{F2}}{I_{F1}} \right) \tag{3}$$

Solving [Equation 3](#) for temperature yields:

$$T = \frac{\Delta V_{BE} \times q}{\eta \times k \times \ln \left( \frac{I_{F2}}{I_{F1}} \right)} \tag{4}$$

[Equation 4](#) holds true when a diode connected transistor such as the MMBT3904 is used. When this “diode” equation is applied to an integrated diode such as a processor transistor with its collector tied to GND as shown in [Figure 12](#) it will yield a wide non-ideality spread. This wide non-ideality spread is not due to true process variation but due to the fact that [Equation 4](#) is an approximation.

TruTherm technology uses the transistor equation, [Equation 5](#), which is a more accurate representation of the topology of the thermal diode found in an FPGA or processor.

$$T = \frac{\Delta V_{BE} \times q}{\eta \times k \times \ln\left(\frac{I_{C2}}{I_{C1}}\right)} \quad (5)$$

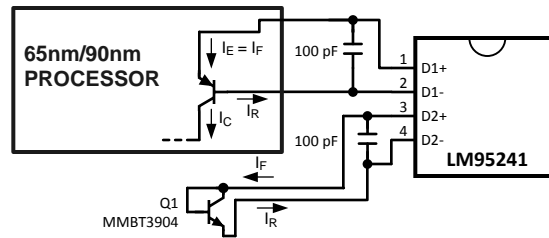

**Figure 12. Thermal Diode Current Paths**

TruTherm should only be enabled when measuring the temperature of a transistor integrated as shown in the processor of [Figure 12](#), because [Equation 5](#) only applies to this topology.

### Calculating Total System Accuracy

The voltage seen by the LM95241 also includes the  $I_F R_S$  voltage drop of the series resistance. The non-ideality factor,  $\eta$ , is the only other parameter not accounted for and depends on the diode that is used for measurement. Since  $\Delta V_{BE}$  is proportional to both  $\eta$  and  $T$ , the variations in  $\eta$  cannot be distinguished from variations in temperature. Since the non-ideality factor is not controlled by the temperature sensor, it will directly add to the inaccuracy of the sensor. For the Pentium D processor on 65nm process, Intel specifies a +4.06%/–0.89% variation in  $\eta$  from part to part when the processor diode is measured by a circuit that assumes diode equation, [Equation 4](#), as true. As an example, assume a temperature sensor has an accuracy specification of  $\pm 1.25^\circ\text{C}$  at a temperature of  $65^\circ\text{C}$  (338 Kelvin) and the processor diode has a non-ideality variation of +4.06%/–0.89%. The resulting system accuracy of the processor temperature being sensed will be:

$$T_{ACC} = + 1.25^\circ\text{C} + (+4.06\% \text{ of } 338 \text{ K}) = +14.97^\circ\text{C} \quad (6)$$

and

$$T_{ACC} = - 1.25^\circ\text{C} + (-0.89\% \text{ of } 338 \text{ K}) = -4.26^\circ\text{C} \quad (7)$$

TrueTherm technology uses the transistor equation, [Equation 5](#), resulting in a non-ideality spread that truly reflects the process variation which is very small. The transistor equation non-ideality spread is  $\pm 0.4\%$  for the Pentium D processor on 65nm process. The resulting accuracy when using TruTherm technology improves to:

$$T_{ACC} = \pm 1.25^\circ\text{C} + (\pm 0.4\% \text{ of } 338 \text{ K}) = \pm 2.60^\circ\text{C} \quad (8)$$

The next error term to be discussed is that due to the series resistance of the thermal diode and printed circuit board traces. The thermal diode series resistance is specified on most processor data sheets. For the Pentium D processor on 65 nm process, this is specified at  $4.52\Omega$  typical. The LM95241 accommodates the typical series resistance of the Pentium D processor on 65nm process. The error that is not accounted for is the spread of the Pentium's series resistance, that is  $2.79\Omega$  to  $6.24\Omega$  or  $\pm 1.73\Omega$ . The equation to calculate the temperature error due to series resistance ( $T_{ER}$ ) for the LM95241 is simply:

$$T_{ER} = R_{PCB} \times 0.62^\circ\text{C}/\Omega \quad (9)$$

Solving [Equation 9](#) for  $R_{PCB}$  equal to  $\pm 1.73\Omega$  results in the additional error due to the spread in the series resistance of  $\pm 1.07^\circ\text{C}$ . The spread in error cannot be canceled out, as it would require measuring each individual thermal diode device. This is quite difficult and impractical in a large volume production environment.

[Equation 9](#) can also be used to calculate the additional error caused by series resistance on the printed circuit board. Since the variation of the PCB series resistance is minimal, the bulk of the error term is always positive and can simply be cancelled out by subtracting it from the output readings of the LM95241.

| Processor Family                | Transistor Equation $n_D$ , non-ideality |       |       | Series R      |
|---------------------------------|--|-------|-------|---------------|
|                                 | min                                      | typ   | max   |               |
| Intel processor on 65nm process | 0.997                                    | 1.001 | 1.005 | 4.52 $\Omega$ |

| Processor Family                               | Diode Equation $\eta_D$ , non-ideality |         |         | Series R      |
|--|--|---------|---------|---------------|
|  | min                                    | typ     | max     |               |
| Pentium III CPUID 67h                          | 1                                      | 1.0065  | 1.0125  |               |
| Pentium III CPUID 68h/PGA370Socket/<br>Celeron | 1.0057                                 | 1.008   | 1.0125  |               |
| Pentium 4, 423 pin                             | 0.9933                                 | 1.0045  | 1.0368  |               |
| Pentium 4, 478 pin                             | 0.9933                                 | 1.0045  | 1.0368  |               |
| Pentium 4 on 0.13 micron process, 2-3.06GHz    | 1.0011                                 | 1.0021  | 1.0030  | 3.64 $\Omega$ |
| Pentium 4 on 90 nm process                     | 1.0083                                 | 1.011   | 1.023   | 3.33 $\Omega$ |
| Pentium on 65 nm process                       | 1.000                                  | 1.009   | 1.050   | 4.52 $\Omega$ |
| Pentium M Processor (Centrino)                 | 1.00151                                | 1.00220 | 1.00289 | 3.06 $\Omega$ |
| MMBT3904                                       |  | 1.003   |         |               |
| AMD Athlon MP model 6                          | 1.002                                  | 1.008   | 1.016   |               |
| AMD Athlon 64                                  | 1.008                                  | 1.008   | 1.096   |               |
| AMD Opteron                                    | 1.008                                  | 1.008   | 1.096   |               |
| AMD Sempron                                    |  | 1.00261 |         | 0.93 $\Omega$ |

### Compensating for Different Non-Ideality

In order to compensate for the errors introduced by non-ideality, the temperature sensor is calibrated for a particular processor. Texas Instruments temperature sensors are always calibrated to the typical non-ideality and series resistance of a given processor type. The LM95241 is calibrated for two non-ideality factors and series resistance values thus supporting the MMBT3904 transistor and the Intel processor on 65nm or 90nm process without the requirement for additional trims. For most accurate measurements TruTherm mode should be turned on when measuring the Intel processor on the 65nm or 90nm process to minimize the error introduced by the false non-ideality spread (see [Diode Non-Ideality Factor Effect on Accuracy](#)). When a temperature sensor calibrated for a particular processor type is used with a different processor type, additional errors are introduced.

Temperature errors associated with non-ideality of different processor types may be reduced in a specific temperature range of concern through use of software calibration. Typical Non-ideality specification differences cause a gain variation of the transfer function, therefore the center of the temperature range of interest should be the target temperature for calibration purposes. The following equation can be used to calculate the temperature correction factor ( $T_{CF}$ ) required to compensate for a target non-ideality differing from that supported by the LM95241.

$$T_{CF} = [(\eta_S - \eta_{Processor}) \div \eta_S] \times (T_{CR} + 273 \text{ K})$$

where

- $\eta_S$  = LM95241 non-ideality for accuracy specification
  - $\eta_T$  = target thermal diode typical non-ideality
  - $T_{CR}$  = center of the temperature range of interest in  $^{\circ}\text{C}$
- (10)

The correction factor of [Equation 10](#) should be directly added to the temperature reading produced by the LM95233. For example when using the LM95241, with the 3904 mode selected, to measure a AMD Athlon processor, with a typical non-ideality of 1.008, for a temperature range of 60  $^{\circ}\text{C}$  to 100  $^{\circ}\text{C}$  the correction factor would calculate to:

$$T_{CF} = [(1.003 - 1.008) \div 1.003] \times (80 + 273) = -1.75^{\circ}\text{C}$$
(11)

Therefore, 1.75 $^{\circ}\text{C}$  should be subtracted from the temperature readings of the LM95241 to compensate for the differing typical non-ideality target.

## PCB LAYOUT FOR MINIMIZING NOISE

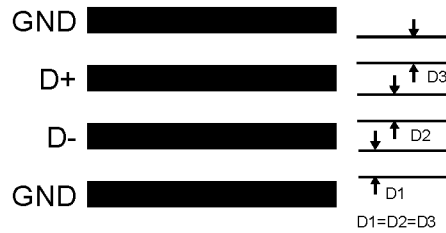

**Figure 13. Ideal Diode Trace Layout**

In a noisy environment, such as a processor mother board, layout considerations are very critical. Noise induced on traces running between the remote temperature diode sensor and the LM95241 can cause temperature conversion errors. Keep in mind that the signal level the LM95241 is trying to measure is in microvolts. The following guidelines should be followed:

1.  $V_{DD}$  should be bypassed with a 0.1 $\mu$ F capacitor in parallel with 100pF. The 100pF capacitor should be placed as close as possible to the power supply pin. A bulk capacitance of approximately 10 $\mu$ F needs to be in the near vicinity of the LM95241.
2. A 100pF diode bypass capacitor is recommended to filter high frequency noise but may not be necessary. Make sure the traces to the 100pF capacitor are matched. Place the filter capacitors close to the LM95241 pins.
3. Ideally, the LM95241 should be placed within 10cm of the Processor diode pins with the traces being as straight, short and identical as possible. Trace resistance of 1 $\Omega$  can cause as much as 1 $^{\circ}$ C of error. This error can be compensated by using simple software offset compensation.
4. Diode traces should be surrounded by a GND guard ring to either side, above and below if possible. This GND guard should not be between the D+ and D- lines. In the event that noise does couple to the diode lines it would be ideal if it is coupled common mode. That is equally to the D+ and D- lines.
5. Avoid routing diode traces in close proximity to power supply switching or filtering inductors.
6. Avoid running diode traces close to or parallel to high speed digital and bus lines. Diode traces should be kept at least 2cm apart from the high speed digital traces.
7. If it is necessary to cross high speed digital traces, the diode traces and the high speed digital traces should cross at a 90 degree angle.
8. The ideal place to connect the LM95241's GND pin is as close as possible to the Processor's GND that is associated with the sense diode.
9. Leakage current between D+ and GND and between D+ and D- should be kept to a minimum. Thirteen nano-amperes of leakage can cause as much as 0.2 $^{\circ}$ C of error in the diode temperature reading. Keeping the printed circuit board as clean as possible will minimize leakage current.

Noise coupling into the digital lines greater than 400mVp-p (typical hysteresis) and undershoot less than 500mV below GND, may prevent successful SMBus communication with the LM95241. SMBus no acknowledge is the most common symptom, causing unnecessary traffic on the bus. Although the SMBus maximum frequency of communication is rather low (100kHz max), care still needs to be taken to ensure proper termination within a system with multiple parts on the bus and long printed circuit board traces. An RC lowpass filter with a 3db corner frequency of about 40MHz is included on the LM95241's SMBCLK input. Additional resistance can be added in series with the SMBDAT and SMBCLK lines to further help filter noise and ringing. Minimize noise coupling by keeping digital traces out of switching power supply areas as well as ensuring that digital lines containing high speed data communications cross at right angles to the SMBDAT and SMBCLK lines.

---

**REVISION HISTORY**

| <b>Changes from Revision D (March 2013) to Revision E</b>  | <b>Page</b>        |
|--|--------------------|
| • Changed layout of National Data Sheet to TI format ..... | <a href="#">22</a> |

---

**PACKAGING INFORMATION**

| Orderable Device   | Status<br>(1) | Package Type | Package Drawing | Pins | Package Qty | Eco Plan<br>(2)         | Lead/Ball Finish<br>(6) | MSL Peak Temp<br>(3) | Op Temp (°C) | Device Marking<br>(4/5) | Samples                 |
|--------------------|---------------|--------------|-----------------|------|-------------|-------------------------|-------------------------|----------------------|--------------|-------------------------|-------------------------|
| LM95241C1MM-1/NOPB | ACTIVE        | VSSOP        | DGK             | 8    | 1000        | Green (RoHS & no Sb/Br) | CU SN                   | Level-1-260C-UNLIM   | 0 to 85      | T29C                    | <a href="#">Samples</a> |
| LM95241C1MM-2/NOPB | ACTIVE        | VSSOP        | DGK             | 8    | 1000        | Green (RoHS & no Sb/Br) | CU SN                   | Level-1-260C-UNLIM   | 0 to 85      | T30C                    | <a href="#">Samples</a> |
| LM95241C1MM/NOPB   | ACTIVE        | VSSOP        | DGK             | 8    | 1000        | Green (RoHS & no Sb/Br) | CU SN                   | Level-1-260C-UNLIM   | 0 to 85      | T28C                    | <a href="#">Samples</a> |
| LM95241C1MMX/NOPB  | ACTIVE        | VSSOP        | DGK             | 8    | 3500        | Green (RoHS & no Sb/Br) | CU SN                   | Level-1-260C-UNLIM   | 0 to 85      | T28C                    | <a href="#">Samples</a> |

(1) The marketing status values are defined as follows:

**ACTIVE:** Product device recommended for new designs.

**LIFEBUY:** TI has announced that the device will be discontinued, and a lifetime-buy period is in effect.

**NRND:** Not recommended for new designs. Device is in production to support existing customers, but TI does not recommend using this part in a new design.

**PREVIEW:** Device has been announced but is not in production. Samples may or may not be available.

**OBSELETE:** TI has discontinued the production of the device.

(2) **RoHS:** TI defines "RoHS" to mean semiconductor products that are compliant with the current EU RoHS requirements for all 10 RoHS substances, including the requirement that RoHS substance do not exceed 0.1% by weight in homogeneous materials. Where designed to be soldered at high temperatures, "RoHS" products are suitable for use in specified lead-free processes. TI may reference these types of products as "Pb-Free".

**RoHS Exempt:** TI defines "RoHS Exempt" to mean products that contain lead but are compliant with EU RoHS pursuant to a specific EU RoHS exemption.

**Green:** TI defines "Green" to mean the content of Chlorine (Cl) and Bromine (Br) based flame retardants meet JS709B low halogen requirements of <=1000ppm threshold. Antimony trioxide based flame retardants must also meet the <=1000ppm threshold requirement.

(3) MSL, Peak Temp. - The Moisture Sensitivity Level rating according to the JEDEC industry standard classifications, and peak solder temperature.

(4) There may be additional marking, which relates to the logo, the lot trace code information, or the environmental category on the device.

(5) Multiple Device Markings will be inside parentheses. Only one Device Marking contained in parentheses and separated by a "-" will appear on a device. If a line is indented then it is a continuation of the previous line and the two combined represent the entire Device Marking for that device.

(6) Lead/Ball Finish - Orderable Devices may have multiple material finish options. Finish options are separated by a vertical ruled line. Lead/Ball Finish values may wrap to two lines if the finish value exceeds the maximum column width.

**Important Information and Disclaimer:**The information provided on this page represents TI's knowledge and belief as of the date that it is provided. TI bases its knowledge and belief on information provided by third parties, and makes no representation or warranty as to the accuracy of such information. Efforts are underway to better integrate information from third parties. TI has taken and

continues to take reasonable steps to provide representative and accurate information but may not have conducted destructive testing or chemical analysis on incoming materials and chemicals. TI and TI suppliers consider certain information to be proprietary, and thus CAS numbers and other limited information may not be available for release.

In no event shall TI's liability arising out of such information exceed the total purchase price of the TI part(s) at issue in this document sold by TI to Customer on an annual basis.

**TAPE AND REEL INFORMATION**

**QUADRANT ASSIGNMENTS FOR PIN 1 ORIENTATION IN TAPE**

\*All dimensions are nominal

| Device             | Package Type | Package Drawing | Pins | SPQ  | Reel Diameter (mm) | Reel Width W1 (mm) | A0 (mm) | B0 (mm) | K0 (mm) | P1 (mm) | W (mm) | Pin1 Quadrant |
|--------------------|--------------|-----------------|------|------|--------------------|--------------------|---------|---------|---------|---------|--------|---------------|
| LM95241C1MM-1/NOPB | VSSOP        | DGK             | 8    | 1000 | 178.0              | 12.4               | 5.3     | 3.4     | 1.4     | 8.0     | 12.0   | Q1            |
| LM95241C1MM-2/NOPB | VSSOP        | DGK             | 8    | 1000 | 178.0              | 12.4               | 5.3     | 3.4     | 1.4     | 8.0     | 12.0   | Q1            |
| LM95241C1MM/NOPB   | VSSOP        | DGK             | 8    | 1000 | 178.0              | 12.4               | 5.3     | 3.4     | 1.4     | 8.0     | 12.0   | Q1            |
| LM95241C1MMX/NOPB  | VSSOP        | DGK             | 8    | 3500 | 330.0              | 12.4               | 5.3     | 3.4     | 1.4     | 8.0     | 12.0   | Q1            |

**TAPE AND REEL BOX DIMENSIONS**

\*All dimensions are nominal

| Device             | Package Type | Package Drawing | Pins | SPQ  | Length (mm) | Width (mm) | Height (mm) |
|--------------------|--------------|-----------------|------|------|-------------|------------|-------------|
| LM95241C1MM-1/NOPB | VSSOP        | DGK             | 8    | 1000 | 210.0       | 185.0      | 35.0        |
| LM95241C1MM-2/NOPB | VSSOP        | DGK             | 8    | 1000 | 210.0       | 185.0      | 35.0        |
| LM95241C1MM/NOPB   | VSSOP        | DGK             | 8    | 1000 | 210.0       | 185.0      | 35.0        |
| LM95241C1MMX/NOPB  | VSSOP        | DGK             | 8    | 3500 | 367.0       | 367.0      | 35.0        |





- NOTES:
- A. All linear dimensions are in millimeters.
  - B. This drawing is subject to change without notice.
  - C. Publication IPC-7351 is recommended for alternate designs.
  - D. Laser cutting apertures with trapezoidal walls and also rounding corners will offer better paste release. Customers should contact their board assembly site for stencil design recommendations. Refer to IPC-7525 for other stencil recommendations.
  - E. Customers should contact their board fabrication site for solder mask tolerances between and around signal pads.

## IMPORTANT NOTICE

Texas Instruments Incorporated (TI) reserves the right to make corrections, enhancements, improvements and other changes to its semiconductor products and services per JESD46, latest issue, and to discontinue any product or service per JESD48, latest issue. Buyers should obtain the latest relevant information before placing orders and should verify that such information is current and complete.

TI's published terms of sale for semiconductor products (<http://www.ti.com/sc/docs/stdterms.htm>) apply to the sale of packaged integrated circuit products that TI has qualified and released to market. Additional terms may apply to the use or sale of other types of TI products and services.

Reproduction of significant portions of TI information in TI data sheets is permissible only if reproduction is without alteration and is accompanied by all associated warranties, conditions, limitations, and notices. TI is not responsible or liable for such reproduced documentation. Information of third parties may be subject to additional restrictions. Resale of TI products or services with statements different from or beyond the parameters stated by TI for that product or service voids all express and any implied warranties for the associated TI product or service and is an unfair and deceptive business practice. TI is not responsible or liable for any such statements.

Buyers and others who are developing systems that incorporate TI products (collectively, "Designers") understand and agree that Designers remain responsible for using their independent analysis, evaluation and judgment in designing their applications and that Designers have full and exclusive responsibility to assure the safety of Designers' applications and compliance of their applications (and of all TI products used in or for Designers' applications) with all applicable regulations, laws and other applicable requirements. Designer represents that, with respect to their applications, Designer has all the necessary expertise to create and implement safeguards that (1) anticipate dangerous consequences of failures, (2) monitor failures and their consequences, and (3) lessen the likelihood of failures that might cause harm and take appropriate actions. Designer agrees that prior to using or distributing any applications that include TI products, Designer will thoroughly test such applications and the functionality of such TI products as used in such applications.

TI's provision of technical, application or other design advice, quality characterization, reliability data or other services or information, including, but not limited to, reference designs and materials relating to evaluation modules, (collectively, "TI Resources") are intended to assist designers who are developing applications that incorporate TI products; by downloading, accessing or using TI Resources in any way, Designer (individually or, if Designer is acting on behalf of a company, Designer's company) agrees to use any particular TI Resource solely for this purpose and subject to the terms of this Notice.

TI's provision of TI Resources does not expand or otherwise alter TI's applicable published warranties or warranty disclaimers for TI products, and no additional obligations or liabilities arise from TI providing such TI Resources. TI reserves the right to make corrections, enhancements, improvements and other changes to its TI Resources. TI has not conducted any testing other than that specifically described in the published documentation for a particular TI Resource.

Designer is authorized to use, copy and modify any individual TI Resource only in connection with the development of applications that include the TI product(s) identified in such TI Resource. NO OTHER LICENSE, EXPRESS OR IMPLIED, BY ESTOPPEL OR OTHERWISE TO ANY OTHER TI INTELLECTUAL PROPERTY RIGHT, AND NO LICENSE TO ANY TECHNOLOGY OR INTELLECTUAL PROPERTY RIGHT OF TI OR ANY THIRD PARTY IS GRANTED HEREIN, including but not limited to any patent right, copyright, mask work right, or other intellectual property right relating to any combination, machine, or process in which TI products or services are used. Information regarding or referencing third-party products or services does not constitute a license to use such products or services, or a warranty or endorsement thereof. Use of TI Resources may require a license from a third party under the patents or other intellectual property of the third party, or a license from TI under the patents or other intellectual property of TI.

TI RESOURCES ARE PROVIDED "AS IS" AND WITH ALL FAULTS. TI DISCLAIMS ALL OTHER WARRANTIES OR REPRESENTATIONS, EXPRESS OR IMPLIED, REGARDING RESOURCES OR USE THEREOF, INCLUDING BUT NOT LIMITED TO ACCURACY OR COMPLETENESS, TITLE, ANY EPIDEMIC FAILURE WARRANTY AND ANY IMPLIED WARRANTIES OF MERCHANTABILITY, FITNESS FOR A PARTICULAR PURPOSE, AND NON-INFRINGEMENT OF ANY THIRD PARTY INTELLECTUAL PROPERTY RIGHTS. TI SHALL NOT BE LIABLE FOR AND SHALL NOT DEFEND OR INDEMNIFY DESIGNER AGAINST ANY CLAIM, INCLUDING BUT NOT LIMITED TO ANY INFRINGEMENT CLAIM THAT RELATES TO OR IS BASED ON ANY COMBINATION OF PRODUCTS EVEN IF DESCRIBED IN TI RESOURCES OR OTHERWISE. IN NO EVENT SHALL TI BE LIABLE FOR ANY ACTUAL, DIRECT, SPECIAL, COLLATERAL, INDIRECT, PUNITIVE, INCIDENTAL, CONSEQUENTIAL OR EXEMPLARY DAMAGES IN CONNECTION WITH OR ARISING OUT OF TI RESOURCES OR USE THEREOF, AND REGARDLESS OF WHETHER TI HAS BEEN ADVISED OF THE POSSIBILITY OF SUCH DAMAGES.

Unless TI has explicitly designated an individual product as meeting the requirements of a particular industry standard (e.g., ISO/TS 16949 and ISO 26262), TI is not responsible for any failure to meet such industry standard requirements.

Where TI specifically promotes products as facilitating functional safety or as compliant with industry functional safety standards, such products are intended to help enable customers to design and create their own applications that meet applicable functional safety standards and requirements. Using products in an application does not by itself establish any safety features in the application. Designers must ensure compliance with safety-related requirements and standards applicable to their applications. Designer may not use any TI products in life-critical medical equipment unless authorized officers of the parties have executed a special contract specifically governing such use. Life-critical medical equipment is medical equipment where failure of such equipment would cause serious bodily injury or death (e.g., life support, pacemakers, defibrillators, heart pumps, neurostimulators, and implantables). Such equipment includes, without limitation, all medical devices identified by the U.S. Food and Drug Administration as Class III devices and equivalent classifications outside the U.S.

TI may expressly designate certain products as completing a particular qualification (e.g., Q100, Military Grade, or Enhanced Product). Designers agree that it has the necessary expertise to select the product with the appropriate qualification designation for their applications and that proper product selection is at Designers' own risk. Designers are solely responsible for compliance with all legal and regulatory requirements in connection with such selection.

Designer will fully indemnify TI and its representatives against any damages, costs, losses, and/or liabilities arising out of Designer's non-compliance with the terms and provisions of this Notice.

## Looking for pricing, stock, or lifecycle information?

Click below to explore more details on WIN SOURCE:

 [View LM95241C1MM-2/NOPB](#) on WIN SOURCE

 [Texas Instruments](#) Information

## Optimize Your Supply Chain with WIN SOURCE Solutions

-  Global Sourcing Solution
-  Obsolete Management
-  Cost Control Management
-  Shortage Management
-  Alternative Solution
-  Excess Inventory Management