



**THE DATASHEET OF
LM9061MX/NOPB**



LM9061 and LM9061-Q1 High-Side Protection Controller

1 Features

- Qualified for Automotive Applications
- AEC-Q100 Qualified With the Following Results:
 - Device HBM ESD Classification Level 2
 - Device CDM ESD Classification Level C4B
- Withstands 60-V Supply Transients
- Overvoltage Shut-OFF With $V_{CC} > 30\text{ V}$
- Lossless Overcurrent Protection Latch-OFF
 - Current Sense Resistor is Not Required
 - Minimizes Power Loss With High Current Loads
- Programmable Delay of Protection Latch-OFF
- Gradual Turnoff to Minimize Inductive Load Transient Voltages
- CMOS Logic-Compatible ON and OFF Control Input

2 Applications

- Transmission Control Units (TCU)
- Engine Control Units (ECU)
- Valve, Relay, and Solenoid Drivers
- Lamp Drivers
- DC Motor PWM Drivers
- Logic-Controlled Power Supply Distribution Switches
- Electronic Circuit Breakers
- High-Power Audio Speakers

3 Description

The LM9061 family consists of charge-pump devices which provides the gate drive to an external power MOSFET of any size configured as a high-side driver or switch. This includes multiple parallel connected MOSFETs for very high current applications. A CMOS logic-compatible ON and OFF input controls the output gate drive voltage. In the ON state, the charge pump voltage, which is well above the available V_{CC} supply, is directly applied to the gate of the MOSFET. A built-in 15-V Zener clamps the maximum gate to source voltage of the MOSFET. When commanded OFF a 110- μA current sink discharges the gate capacitances of the MOSFET for a gradual turnoff characteristic to minimize the duration of inductive load transient voltages and further protect the power MOSFET.

Lossless protection of the power MOSFET is a key feature of the LM9061. The voltage drop (V_{DS}) across the power device is continually monitored and compared against an externally programmable threshold voltage. A small current-sensing resistor in series with the load, which causes a loss of available energy, is not required for the protection circuitry. If the V_{DS} voltage, due to excessive load current, exceeds the threshold voltage, the output is latched OFF in a more gradual fashion (through a 10- μA output current sink) after a programmable delay time interval.

Device Information⁽¹⁾

PART NUMBER	PACKAGE	BODY SIZE (NOM)
LM9061, LM9061-Q1	SOIC (8)	4.9 mm x 3.91 mm

(1) For all available packages, see the orderable addendum at the end of the data sheet.

High-Side Driving and Protection to a Connected Load

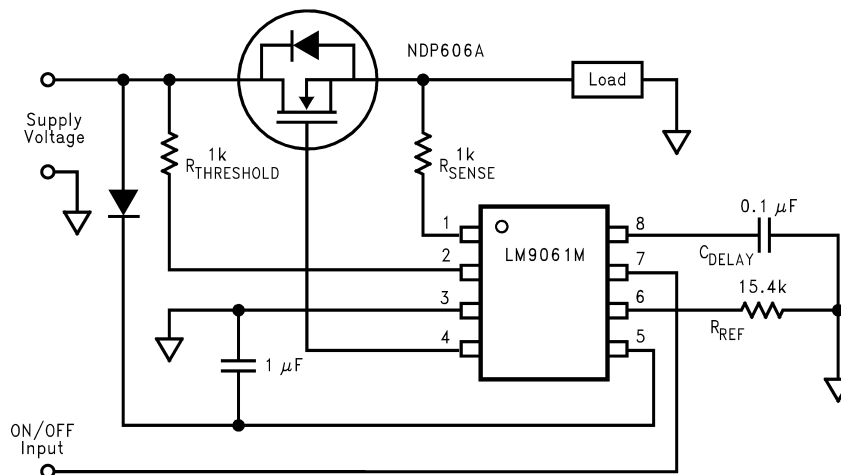

Table of Contents

1 Features 1 2 Applications 1 3 Description 1 4 Revision History 2 5 Pin Configuration and Functions 3 6 Specifications 4 6.1 Absolute Maximum Ratings 4 6.2 ESD Ratings: LM9061 4 6.3 ESD Ratings: LM9061-Q1 4 6.4 Recommended Operating Conditions 4 6.5 Thermal Information 5 6.6 Electrical Characteristics 5 6.7 Switching Characteristics 6 6.8 Typical Characteristics 8 7 Detailed Description 10 7.1 Overview 10 7.2 Functional Block Diagram 10 7.3 Feature Description 10	7.4 Device Functional Modes 20 8 Application and Implementation 21 8.1 Application Information 21 8.2 Typical Applications 21 9 Power Supply Recommendations 24 10 Layout 25 10.1 Layout Guidelines 25 10.2 Layout Examples 25 11 Device and Documentation Support 26 11.1 Documentation Support 26 11.2 Related Links 26 11.3 Receiving Notification of Documentation Updates 26 11.4 Community Resources 26 11.5 Trademarks 26 11.6 Electrostatic Discharge Caution 26 11.7 Glossary 26 12 Mechanical, Packaging, and Orderable Information 26
------------------------------------------------------------------------------------------------------------------------------------------------------------------------------------------------------------------------------------------------------------------------------------------------------------------------------------------------------------------------------------------------------------------------------------------------------------------------------------------------------------------------------------------------------------------------------------------------------------------------------------------------------------------------------------------------------	-------------------------------------------------------------------------------------------------------------------------------------------------------------------------------------------------------------------------------------------------------------------------------------------------------------------------------------------------------------------------------------------------------------------------------------------------------------------------------------------------------------------------------------------------------------------------------------------------------------------------------------------------------------------------------------------------------------------------------------------

4 Revision History

NOTE: Page numbers for previous revisions may differ from page numbers in the current version.

Changes from Revision H (January 2015) to Revision I	Page
<ul style="list-style-type: none"> • Updated data sheet text to the latest TI documentation and translations standards and flow 1 • Added <i>Bidirectional Applications</i> section 23 	
Changes from Revision G (November 2014) to Revision H	Page
<ul style="list-style-type: none"> • Changed <i>Handling Ratings</i> to <i>ESD Ratings</i> 4 • Added content to <i>Application and Implementation</i> section 21 • Changed Layout Example figure 25 	
Changes from Revision F (April 1995) to Revision G	Page
<ul style="list-style-type: none"> • Added AEC-Q100 Qualification 1 • Added Handling Ratings table, Thermal Information table, Feature Description section, Device Functional Modes, Application and Implementation section, Power Supply Recommendations section, Layout section, Device and Documentation Support section, and Mechanical, Packaging, and Orderable Information section 4 	
Changes from Revision E (April 2013) to Revision F	Page
<ul style="list-style-type: none"> • Changed layout of National Data Sheet to TI format 19 	

5 Pin Configuration and Functions

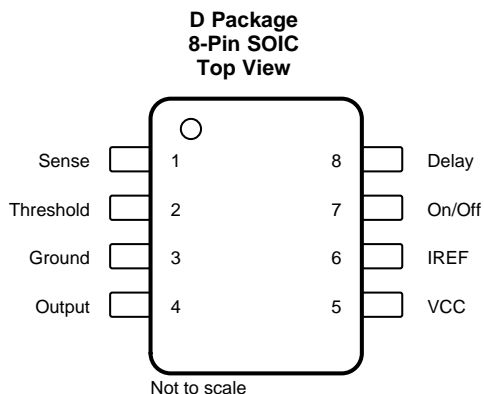

Pin Functions

PIN		I/O	DESCRIPTION
NAME	NO.		
Sense	1	I	The inverting input to the protection comparator, connected to the external MOSFET source pin and the load.
Threshold	2	I	The noninverting input to the protection comparator, and a current sink for the threshold resistor to set the allowed voltage drop across the external MOSFET.
Ground	3	—	Ground
Output	4	O	The gate drive connection. Charges, and discharges, the MOSFET gate.
V _{CC}	5	I	The voltage supply pin. The V _{CC} operating range has a minimum value of 7 V, and a maximum value of 26 V.
I _{REF}	6	O	A resistor on this pin to ground sets the current through the threshold resistor, which sets the allowed voltage drop across the external MOSFET.
On/Off	7	I	The control pin. A low voltage, V _{IN(0)} , will disable device operation, while a high voltage, V _{IN(1)} , will enable device operation.
Delay	8	O	A capacitor on this pin to ground will provide a delay time between when the protection comparator detects excessive V _{GS} across the MOSFET and when the gate drive circuitry is latched-OFF.

6 Specifications

6.1 Absolute Maximum Ratings

over operating free-air temperature range (unless otherwise noted)⁽¹⁾⁽²⁾

	MIN	MAX	UNIT
Supply voltage		60	V
Output voltage		$V_{CC} + 15$	V
Voltage at sense and threshold (through 1 k Ω)	-25	60	V
ON/OFF input voltage	-0.3	$V_{CC} + 0.3$	V
Reverse supply current		20	mA
Junction temperature		150	°C
Lead temperature soldering, 10 seconds		260	°C
Storage temperature, T_{stg}	-55	150	°C

- Stresses beyond those listed under *Absolute Maximum Ratings* may cause permanent damage to the device. These are stress ratings only, which do not imply functional operation of the device at these or any other conditions beyond those indicated under *Recommended Operating Conditions*⁹. Exposure to absolute-maximum-rated conditions for extended periods may affect device reliability.
- If Military/Aerospace specified devices are required, please contact the Texas Instruments Sales Office/ Distributors for availability and specifications.

6.2 ESD Ratings: LM9061

		VALUE	UNIT
$V_{(ESD)}$ Electrostatic discharge	Human-body model (HBM), per ANSI/ESDA/JEDEC JS-001 ⁽¹⁾	± 2000	V
	Charged-device model (CDM), per JEDEC specification JESD22-C101 ⁽²⁾	± 1000	

- JEDEC document JEP155 states that 500-V HBM allows safe manufacturing with a standard ESD control process.
- JEDEC document JEP157 states that 250-V CDM allows safe manufacturing with a standard ESD control process.

6.3 ESD Ratings: LM9061-Q1

		VALUE	UNIT	
$V_{(ESD)}$ Electrostatic discharge	Human-body model (HBM), per AEC Q100-002 ⁽¹⁾	± 2000	V	
	Charged-device model (CDM), per AEC Q100-011	All pins except 1, 4, 5, and 8		± 1000
		Pins 1, 4, 5, and 8		± 1000

- AEC Q100-002 indicates that HBM stressing shall be in accordance with the ANSI/ESDA/JEDEC JS-001 specification.

6.4 Recommended Operating Conditions⁽¹⁾

over operating free-air temperature range (unless otherwise noted)

	MIN	NOM	MAX	UNIT
Supply voltage	7		26	V
ON/OFF input voltage	-0.3		V_{CC}	V
Ambient temperature: LM9061	-40		125	°C
Junction temperature: LM9061-Q1	-40		125	°C

- Operating Ratings indicate conditions for which the device is intended to be functional, but may not meet the ensured specific performance limits. For ensured specifications and test conditions see the *Typical Characteristics*.

6.5 Thermal Information

THERMAL METRIC ⁽¹⁾		LM9061, LM9061-Q1	UNIT
		D (SOIC)	
		8 PINS	
$R_{\theta JA}$	Junction-to-ambient thermal resistance	150	°C/W
$R_{\theta JC(top)}$	Junction-to-case (top) thermal resistance	46.7	°C/W
$R_{\theta JB}$	Junction-to-board thermal resistance	49.1	°C/W
Ψ_{JT}	Junction-to-top characterization parameter	6.2	°C/W
Ψ_{JB}	Junction-to-board characterization parameter	48.4	°C/W

(1) For more information about traditional and new thermal metrics, see the [IC Package Thermal Metrics](#) application report.

6.6 Electrical Characteristics

over operating free-air temperature range (unless otherwise noted)

7 V ≤ V_{CC} ≤ 20 V, R_{REF} = 15.4 kΩ, -40°C ≤ T_J ≤ +125°C, unless otherwise specified.

PARAMETER	TEST CONDITIONS	MIN	TYP	MAX	UNIT
POWER SUPPLY					
I _Q	Quiescent supply current	ON/OFF = 0		5	mA
I _{CC}	Operating supply current	ON/OFF = 1, C _{LOAD} = 0.025 μF, includes turnon transient output current		40	mA
ON/OFF CONTROL INPUT					
V _{IN(0)}	ON/OFF input logic 0	V _{OUT} = OFF		1.5	V
V _{IN(1)}	ON/OFF input logic 1	V _{OUT} = ON	3.5		V
V _{HYST}	ON/OFF input hysteresis	Peak-to-peak	0.8	2	V
I _{IN}	ON/OFF input pulldown current	V _{ON/OFF} = 5 V	50	250	μA
GATE DRIVE OUTPUT					
V _{OH}	Charge pump output voltage	ON/OFF = 1	V _{CC} + 7	V _{CC} + 15	V
V _{OL}	OFF output voltage	ON/OFF = 0, I _{SINK} = 110 μA		0.9	V
V _{CLAMP}	Sense to output clamp voltage	ON/OFF = 1, V _{SENSE} = V _{THRESHOLD}	11	15	V
I _{SINK(Normal-OFF)}	Output sink current normal operation	ON/OFF = 0, V _{DELAY} = 0 V, V _{SENSE} = V _{THRESHOLD}	75	145	μA
I _{SINK(Latch-OFF)}	Output sink current with protection comparator tripped	V _{DELAY} = 7 V, V _{SENSE} < V _{THRESHOLD}	5	15	μA
PROTECTION CIRCUITRY					
V _{REF}	Reference voltage		1.15	1.35	V
I _{REF}	Threshold pin reference current	V _{SENSE} = V _{THRESHOLD}	75	88	μA
I _{THR(LEAKAGE)}	Threshold pin leakage current	V _{CC} = Open, 7 V ≤ V _{THRESHOLD} ≤ 20 V		10	μA
I _{SENSE}	Sense pin input bias current	V _{SENSE} = V _{THRESHOLD}		10	μA
DELAY TIMER					
V _{TIMER}	Delay timer threshold voltage		5	6.2	V
V _{SAT}	Discharge transistor saturation voltage	I _{DIS} = 1 mA		0.4	V
I _{DIS}	Delay capacitor discharge current	V _{DELAY} = 5 V	2	10	mA
I _{DELAY}	Delay pin source current		6.74	15.44	μA

6.7 Switching Characteristics

over operating free-air temperature range (unless otherwise noted)

$7V \leq V_{CC} \leq 20V$, $R_{REF} = 15.4\text{ k}\Omega$, $-40^\circ\text{C} \leq T_J \leq +125^\circ\text{C}$, $C_{LOAD} = 0.025\text{ }\mu\text{F}$, $C_{DELAY} = 0.022\text{ }\mu\text{F}$, unless otherwise specified.

PARAMETER	TEST CONDITIONS	MIN	TYP	MAX	UNIT
T_{ON} Output turnon time	$C_{LOAD} = 0.025\text{ }\mu\text{F}$	$7V \leq V_{CC} \leq 10V$, $V_{OUT} \geq V_{CC} + 7V$		1.5	ms
		$10V \leq V_{CC} \leq 20V$, $V_{OUT} \geq V_{CC} + 11V$		1.5	
$T_{OFF(NORMAL)}$ Output turnoff time, normal operation ⁽¹⁾	$C_{LOAD} = 0.025\text{ }\mu\text{F}$ $V_{CC} = 14V$, $V_{OUT} \geq 25V$ $V_{SENSE} = V_{THRESHOLD}$	4		10	ms
$T_{OFF(Latch-OFF)}$ Output turnoff time, protection comparator tripped ⁽¹⁾	$C_{LOAD} = 0.025\text{ }\mu\text{F}$ $V_{CC} = 14V$, $V_{OUT} \geq 25V$ $V_{SENSE} = V_{THRESHOLD}$	45		140	ms
T_{DELAY} Delay timer interval	$C_{DELAY} = 0.022\text{ }\mu\text{F}$	8		18	ms

(1) The AC Timing specifications for T_{OFF} are not production tested, and therefore are not specifically ensured. Limits are provided for reference purposes only. Smaller load capacitances will have proportionally faster turn-ON and turn-OFF times.

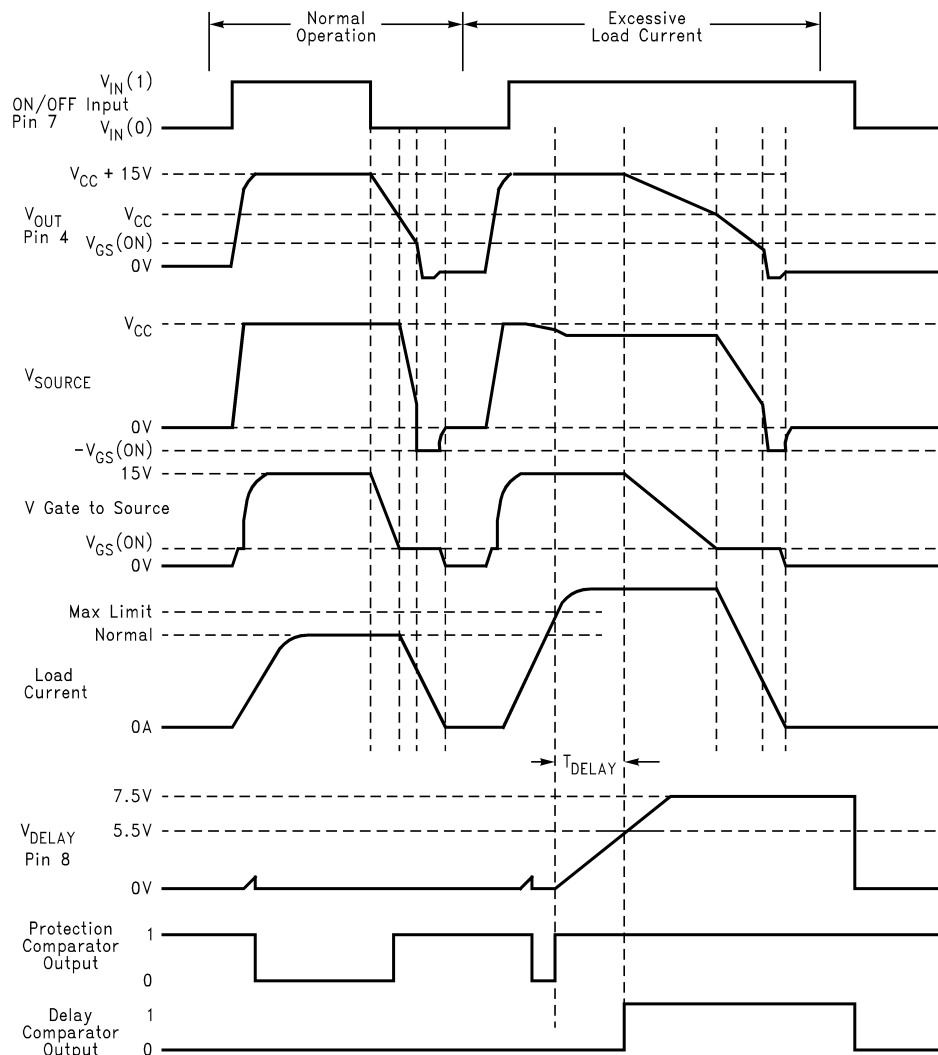

Figure 1. Typical Operating Waveforms

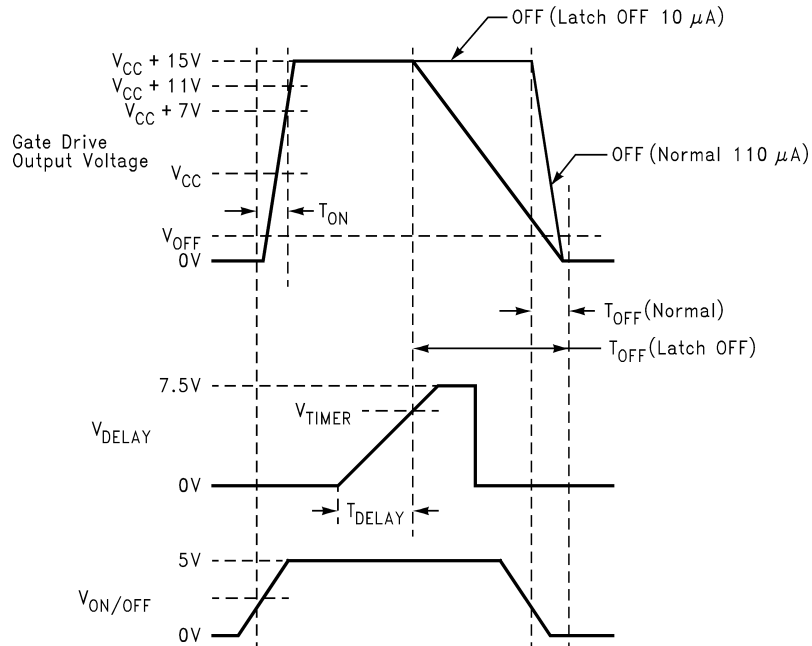
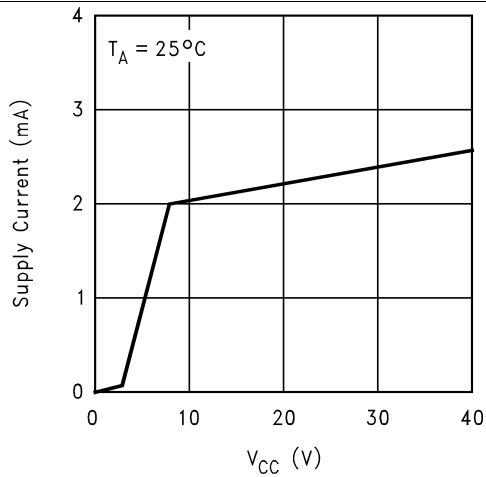
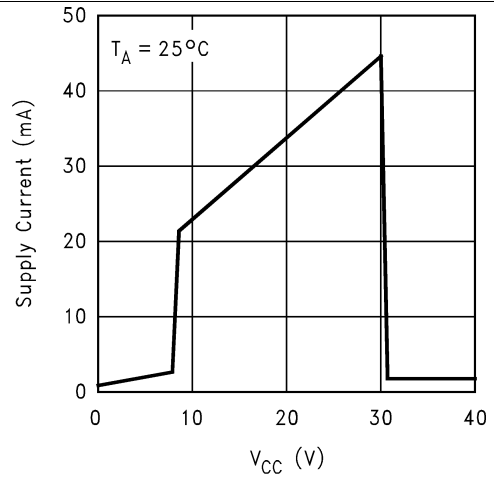
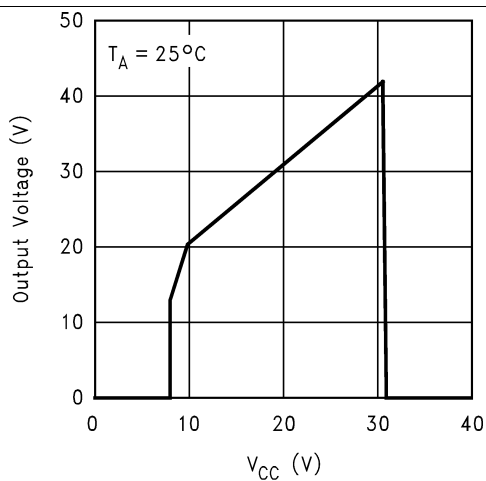
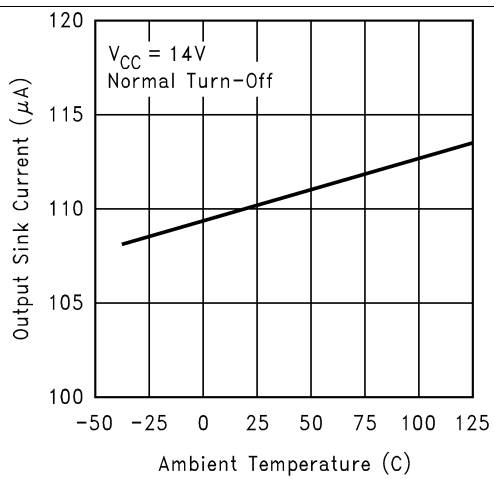
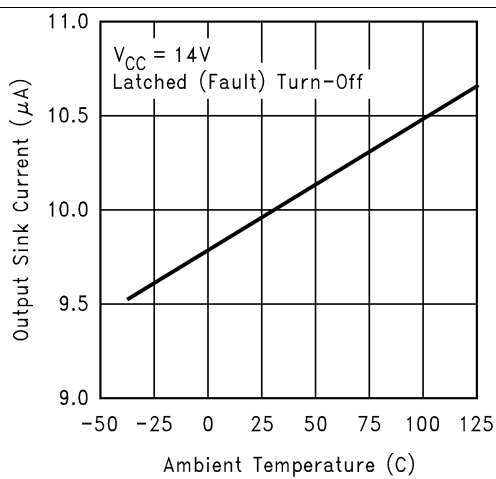
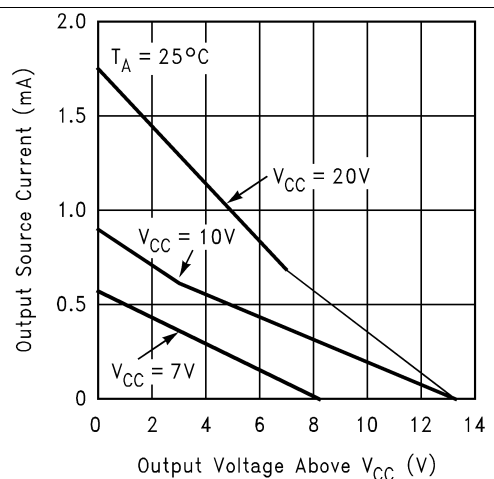

Figure 2. Timing Definitions

6.8 Typical Characteristics

Figure 3. Standby Supply Current vs V_{CC}

Figure 4. Operating Supply Current vs V_{CC}

Figure 5. Output Voltage vs V_{CC}

Figure 6. Output Sink Current vs Temperature

Figure 7. Output Sink Current vs Temperature

Figure 8. Output Source Current vs Output Voltage

Typical Characteristics (continued)

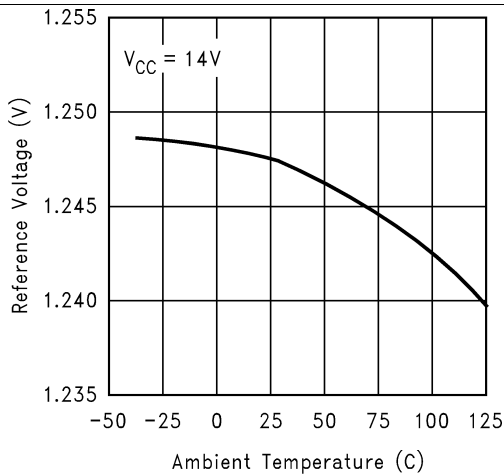

Figure 9. Reference Voltage vs Temperature

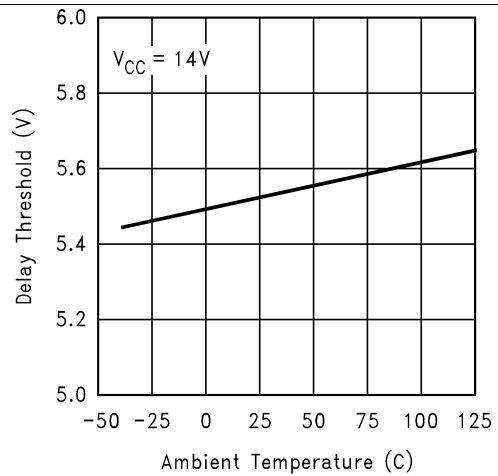

Figure 10. Delay Threshold vs Temperature

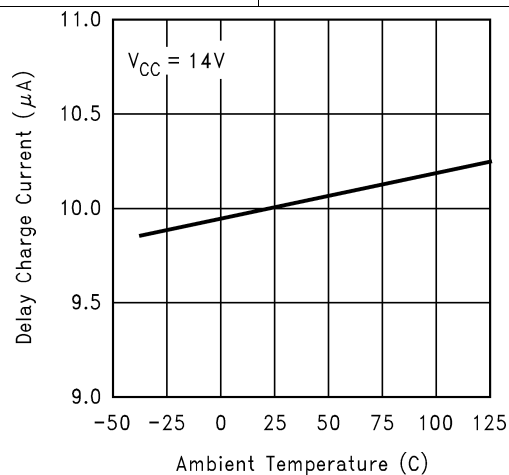

Figure 11. Delay Charge Current vs Temperature

7 Detailed Description

7.1 Overview

The LM9061 is a high-side controller that can protect the load from overcurrent and overvoltage. An internal charge pump circuit generates the gate voltage to drive the high-side MOSFET. The voltage drop, V_{DS} , across the MOSFET is monitored to protect from excessive current. If the V_{DS} voltage, due to excessive load current, exceed the threshold voltage, the output is latched OFF after a programmable delay time interval.

7.2 Functional Block Diagram

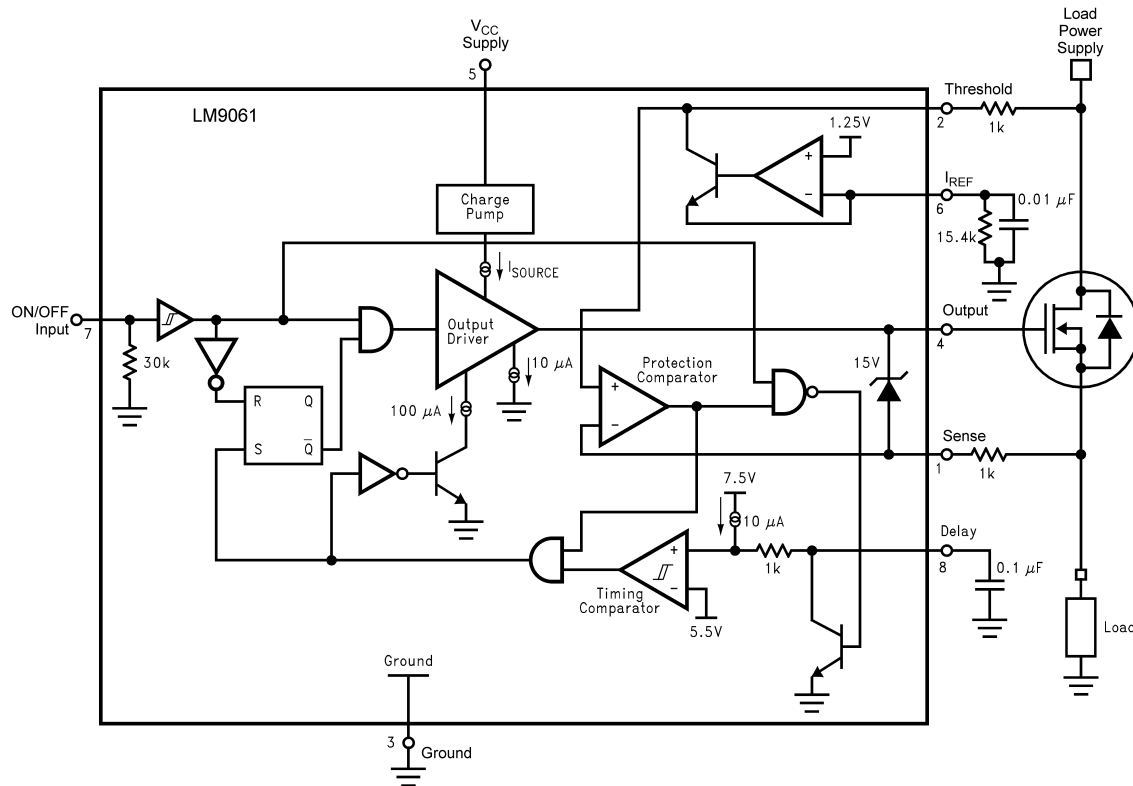

7.3 Feature Description

7.3.1 MOSFET Gate Drive

The LM9061 contains a charge pump circuit that generates a voltage in excess of the applied supply voltage to provide the gate drive to high-side MOSFET transistors. Any size of N-channel power MOSFET, including multiple parallel connected MOSFETs for very high current applications, can be used to apply power to a ground referenced load circuit in what is referred to as *high-side drive* applications. Figure 12 shows the basic application of the LM9061.

Feature Description (continued)

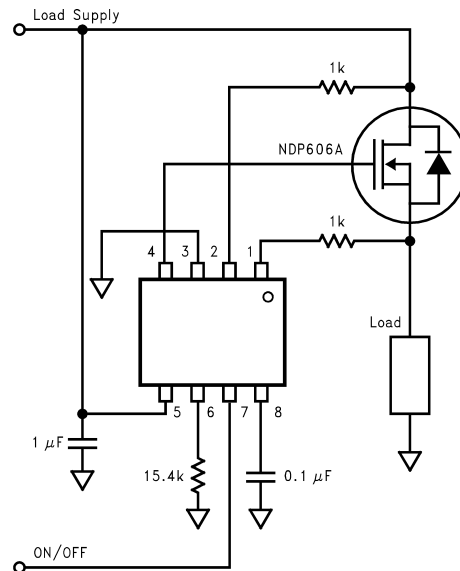

Figure 12. Basic Application Circuit

7.3.2 Basic Operation

When commanded ON by a logic 1 input to pin 7 the gate drive output, pin 4, rises quickly to the V_{CC} supply potential at pin 5. Once the gate voltage exceeds the gate-source threshold voltage of the MOSFET, $V_{GS(ON)}$, (the source is connected to ground through the load) the MOSFET turns ON and connects the supply voltage to the load. With the source at near the supply potential, the charge pump continues to provide a gate voltage greater than the supply to keep the MOSFET turned ON. To protect the gate of the MOSFET, the output voltage of the LM9061 is clamped to limit the maximum V_{GS} to 15 V.

It is important to remember that during the Turnon of the MOSFET the output current to the Gate is drawn from the V_{CC} supply pin. The V_{CC} pin must be bypassed with a capacitor with a value of at least 10 times the Gate capacitance, and no less than 0.1 μF . The output current into the Gate will typically be 30 mA with V_{CC} at 14 V and the Gate at 0 V. As the Gate voltage rises to V_{CC} , the output current decreases. When the Gate voltage reaches V_{CC} , the output current will typically be 1 mA with V_{CC} at 14 V.

A logic 0 on pin 7 turns the MOSFET OFF. When commanded OFF a 110- μA current sink is connected to the output pin. This current discharges the gate capacitances of the MOSFET linearly. When the gate voltage equals the source voltage (which is near the supply voltage) plus the $V_{GS(ON)}$ threshold of the MOSFET, the source voltage starts following the gate voltage and ramps toward ground. Eventually the source voltage equals 0 V and the gate continues to ramp to zero thus turning OFF the power device. This gradual turnoff characteristic, instead of an abrupt removal of the gate drive, can, in some applications, minimize the power dissipation in the MOSFET or reduce the duration of negative transients, as is the case when driving inductive loads. In the event of an overstress condition on the power device, the turnoff characteristic is even more gradual as the output sinking current is only 10 μA (see [Lossless Overcurrent Protection](#)).

7.3.3 Turn On and Turn Off Characteristics

The actual rate of change of the voltage applied to the gate of the power device is directly dependent on the input capacitances of the MOSFET used. These times are important to know if the power to the load is to be applied repetitively as is the case with pulse width modulation drive. Of concern are the capacitances from gate to drain, C_{GD} , and from gate to source, C_{GS} . Figure 13 details the turnon and turnoff intervals in a typical application. An inductive load is assumed to illustrate the output transient voltage to be expected. At time t_1 , the ON/OFF input goes high. The output, which drives the gate of the MOSFET, immediately pulls the gate voltage

Feature Description (continued)

towards the V_{CC} supply of the LM9061. The source current from pin 4 is typically 30 mA which quickly charges C_{GD} and C_{GS} . As soon as the gate reaches the $V_{GS(ON)}$ threshold of the MOSFET, the switch turns ON and the source voltage starts rising towards V_{CC} . V_{GS} remains equal to the threshold voltage until the source reaches V_{CC} . While V_{GS} is constant only C_{GD} is charging. When the source voltage reaches V_{CC} , at time t_2 , the charge pump takes over the drive of the gate to ensure that the MOSFET remains ON.

The charge pump is basically a small internal capacitor that acquires and transfers charge to the output pin. The clock rate is set internally at typically 300 kHz. In effect the charge pump acts as a switched capacitor resistor (approximately 67k) connected to a voltage that is clamped at 13 V above the Sense input pin of the LM9061 which is equal to the V_{CC} supply in typical applications. The gate voltage rises above V_{CC} in an exponential fashion with a time constant dependent upon the sum of C_{GD} and C_{GS} . At this time however the load is fully energized. At time t_3 , the charge pump reaches its maximum potential and the switch remains ON.

At time t_4 , the ON/OFF input goes low to turn off the MOSFET and remove power from the load. At this time the charge pump is disconnected and an internal 110- μ A current sink begins to discharge the gate input capacitances to ground. The discharge rate ($\Delta V/\Delta T$) is equal to 110 μ A / ($C_{GD} + C_{GS}$).

The load is still fully energized until time t_5 when the gate voltage has reached a potential of the source voltage (V_{CC}) plus the $V_{GS(ON)}$ threshold voltage of the MOSFET. Between time t_5 and t_6 , the V_{GS} voltage remains constant and the source voltage follows the gate voltage. With the voltage on C_{GD} held constant the discharge rate now becomes 110 μ A/ C_{GD} .

At time t_6 the source voltage reaches 0 V. As the gate moves below the $V_{GS(ON)}$ threshold the MOSFET tries to turn off. With an inductive load, if the current in the load has not collapsed to zero by time t_6 , the action of the MOSFET turning off creates a negative voltage transient (flyback) across the load. The negative transient will be clamped to $-V_{GS(ON)}$ because the MOSFET must turn itself back on to continue conducting the load current until the energy in the inductance has been dissipated (at time t_7).

7.3.4 Lossless Overcurrent Protection

A unique feature of the LM9061 is the ability to sense excessive power dissipation in the MOSFET and latch it OFF to prevent permanent failure. Instead of sensing the actual current flowing through the MOSFET to the load, which typically requires a small valued power resistor in series with the load, the LM9061 monitors the voltage drop from drain to source, V_{DS} , across the MOSFET. This *lossless* technique allows all of the energy available from the supply to be conducted to the load as required. The only power loss is that of the MOSFET itself and proper selection of a particular power device for an application minimizes this concern. Another benefit of this technique is that all applications use only standard inexpensive 1/4W or less resistors.

To use this lossless protection technique requires knowledge of key characteristics of the power MOSFET used. In any application the emphasis for protection can be placed on either the power MOSFET or on the amount of current delivered to the load, with the assumption that the selected MOSFET can safely handle the maximum load current.

Feature Description (continued)

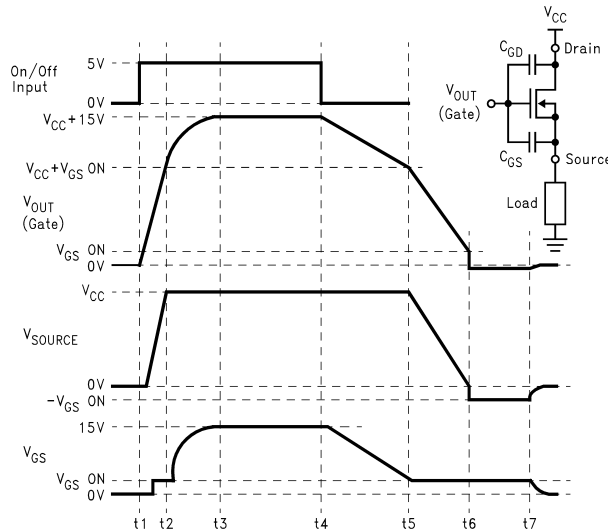

Figure 13. Turnon and Turnoff Waveforms

To protect the MOSFET from exceeding its maximum junction temperature rating, the power dissipation must be limited. The maximum power dissipation allowed (derated for temperature) and the maximum drain to source ON resistance, $R_{DS(ON)}$, with both at the maximum operating ambient temperature, must be determined. When switched ON the power dissipation in the MOSFET is calculated by [Equation 1](#):

$$P_{DISS} = \frac{V_{DS}^2}{R_{DS(ON)}} \quad (1)$$

The V_{DS} voltage to limit the maximum power dissipation is therefore calculated by [Equation 2](#):

$$V_{DS (MAX)} = \sqrt{P_{D (MAX)} \times R_{DS(ON) (MAX)}} \quad (2)$$

With this restriction, the actual load current and power dissipation obtained is a direct function of the actual $R_{DS(ON)}$ of the MOSFET at any particular ambient temperature but the junction temperature of the power device never exceeds its rated maximum.

To limit the maximum load current requires an estimate of the minimum $R_{DS(ON)}$ of the MOSFET (the minimum $R_{DS(ON)}$ of discrete MOSFETs is rarely specified) over the required operating temperature range.

The maximum current to the load is calculated by [Equation 3](#):

$$I_{LOAD (MAX)} = \frac{V_{DS}}{R_{DS(ON) (MIN)}} \quad (3)$$

The maximum junction temperature of the MOSFET or the maximum current to the load can be limited by monitoring and setting a maximum operational value for the drain to source voltage drop, V_{DS} . In addition, in the event that the load is inadvertently shorted to ground, the power device is automatically be turned off.

In all cases, if the MOSFET be switched OFF by the built in protection comparator, the output sink current is switched to only 10 μ A to gradually turn off the power device.

[Figure 14](#) illustrates how the threshold voltage for the internal protection comparator is established.

Feature Description (continued)

Two resistors connect the drain and source of the MOSFET to the LM9061. The Sense input, pin 1, monitors the source voltage while the Threshold input, pin 2, is connected to the drain, which is also connected to the constant load power supply. Both of these inputs are the two inputs to the protection comparator. If the voltage at the sense input ever drop below the voltage at the threshold input, the protection comparator output goes high and initiates an automatic latch-OFF function to protect the power device. Therefore the switching threshold voltage of the comparator directly controls the maximum V_{DS} allowed across the MOSFET while conducting load current.

The threshold voltage is set by the voltage drop across resistor $R_{THRESHOLD}$. A reference current is fixed by a resistor to ground at I_{REF} , pin 6. To precisely regulate the reference current over temperature, a stable band gap reference voltage is provided to bias a constant current sink. The reference current is set by [Equation 4](#):

$$I_{REF} = \frac{V_{REF}}{R_{REF}} \quad (4)$$

The reference current sink output is internally connected to the threshold pin. I_{REF} then flows from the load supply through $R_{THRESHOLD}$. The fixed voltage drop across $R_{THRESHOLD}$ is approximately equal to the maximum value of V_{DS} across the MOSFET before the protection comparator trips.

It is important to note that the programmed reference current serves a multiple purpose as it is used internally for biasing and also has a direct effect on the internal charge pump switching frequency. The design of the LM9061 is optimized for a reference current of approximately 80 μA , set with a 15.4 k Ω $\pm 1\%$ resistor for R_{REF} . To obtain the ensured performance characteristics, TI recommends using a 15.4-k Ω resistor for R_{REF} .

The protection comparator is configured such that during normal operation, when the output of the comparator is low, the differential input stage of the comparator is switched in a manner that there is virtually no current flowing into the noninverting input of the comparator. Therefore, only I_{REF} flows through resistor $R_{THRESHOLD}$. All of the input bias current, 20 μA maximum, for the comparator input stage (twice the I_{SENSE} specification of 10 μA maximum, defined for equal potentials on each of the comparator inputs) however flows into the inverting input through resistor R_{SENSE} . At the comparator threshold, the current through R_{SENSE} is no more than the I_{SENSE} specification of 10 μA .

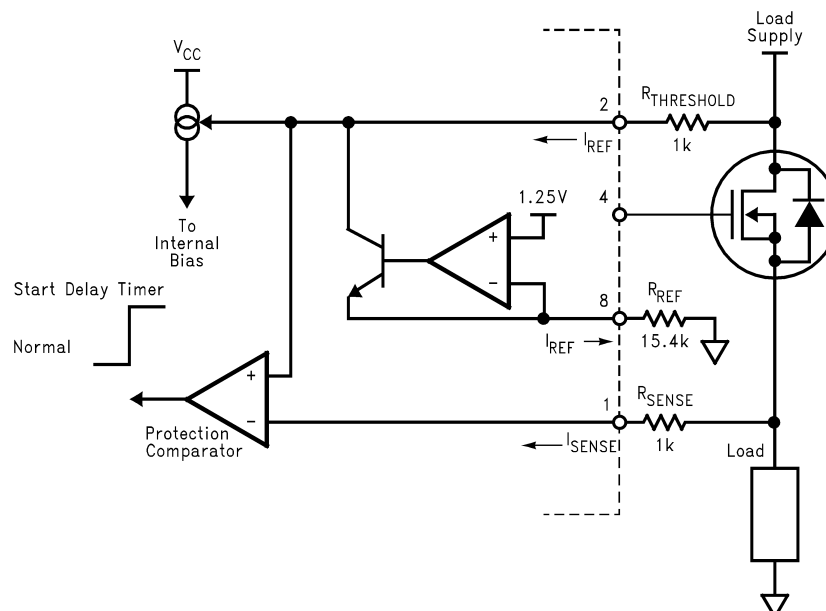

Figure 14. Protection Comparator Biasing

To tailor the $V_{DS (MAX)}$ threshold for any particular application, the resistor $R_{THRESHOLD}$ can be selected per [Equation 5](#):

Feature Description (continued)

$$V_{DS (MAX)} = \frac{V_{REF} \times R_{THR}}{R_{REF}} - (I_{SENSE} \times R_{SENSE}) + V_{OS}$$

where

- $R_{REF} = 15.4 \text{ k}\Omega$.
- I_{SENSE} is the input bias current to the protection comparator.
- R_{SENSE} is the resistor connected to pin 1.
- V_{OS} is the offset voltage of the protection comparator (typically in the range of $\pm 10 \text{ mV}$). (5)

The resistor R_{SENSE} is optional, but TI strongly recommends providing transient protection for the Sense pin, especially when driving inductive type loads. A minimum value of $1 \text{ k}\Omega$ protects the pin from transients ranging from -25 V to $+60 \text{ V}$. This resistor must be equal to, or less than, the resistor used for $R_{THRESHOLD}$. Never set R_{SENSE} to a value larger than $R_{THRESHOLD}$. When the protection comparator output goes high, the total bias current for the input stage transfers from the Sense pin to the Threshold pin, thereby changing the voltages present at the inputs to the comparator. For consistent switching of the comparator right at the desired threshold point, the voltage drop that occurs at the noninverting input (Threshold) must equal, or exceed, the rise in voltage at the inverting input (Sense).

A bypass capacitor across R_{REF} is optional and is used to help keep the reference voltage constant in applications where the V_{CC} supply is subject to high levels of transient noise. This bypass capacitor must be no larger than $0.1 \mu\text{F}$, and is not needed for most applications.

7.3.5 Delay Timer

To allow the MOSFET to conduct currents beyond the protection threshold for a brief period of time, a delay timer function is provided. This timer delays the actual latching OFF of the MOSFET for a programmable interval. This feature is important to drive loads which require a surge of current in excess of the normal ON current upon start-up, or at any point in time, such as lamps and motors. [Figure 15](#) details the delay timer circuitry. A capacitor connected from the Delay pin 8, to ground sets the delay time interval. With the MOSFET turned ON and all conditions normal, the output of the protection comparator is low and this keeps the discharge transistor ON. This transistor keeps the delay capacitor discharged. If a surge of load current trips the protection comparator high, the discharge transistor turns off and an internal $10\text{-}\mu\text{A}$ current source begins linearly charging the delay capacitor.

If the surge current, with excessive V_{DS} voltage, lasts long enough for the capacitor to charge to the timing comparator threshold of typically 5.5 V , the output of the comparator goes high to set a flip-flop and immediately latch the MOSFET OFF. It does not restart until the ON/OFF Input is toggled low then high.

The delay time interval is set by the selection of C_{DELAY} and can be found in [Equation 6](#):

$$T_{DELAY} = \frac{(V_{TIMER} \times C_{DELAY})}{I_{DELAY}}$$

where

- Typically, $V_{TIMER} = 5.5 \text{ V}$.
- $I_{DELAY} = 10 \mu\text{A}$. (6)

Charging of the delay capacitor is clamped at approximately 7.5 V which is the internal bias voltage for the $10\text{-}\mu\text{A}$ current source.

Feature Description (continued)

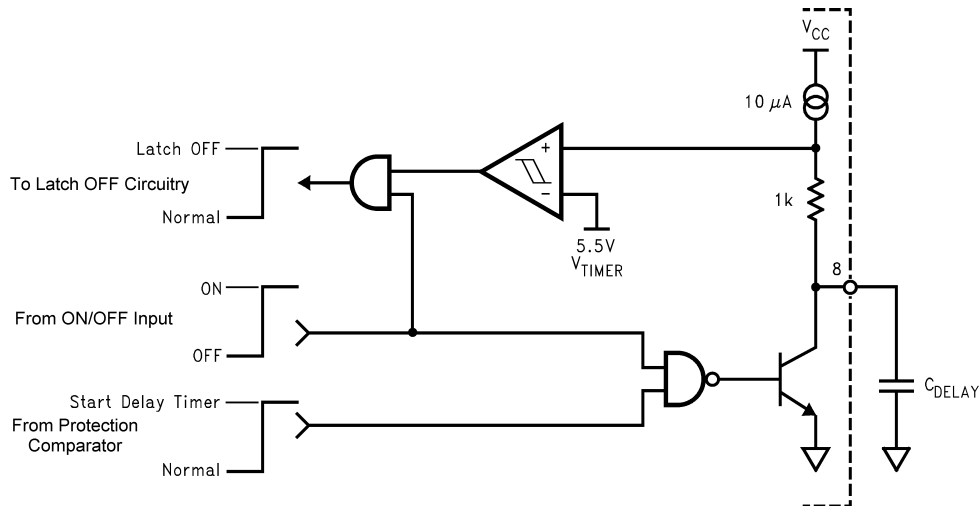

Figure 15. Delay Timer

7.3.5.1 Minimum Delay Time

A minimum delay time interval is required in all applications due to the nature of the protection circuitry. At the instant the MOSFET is commanded ON, the voltage across the MOSFET, V_{DS} , is equal to the full load supply voltage because the source is held at ground by the load. This condition immediately trips the protection comparator. Without a minimum delay time set, the timing comparator trips and forces the MOSFET to latch-OFF thereby never allowing the load to be energized.

To prevent this situation a delay capacitor is required at pin 8. The selection of a minimum capacitor value to ensure proper start-up depends primarily on the load characteristics and how much time is required for the MOSFET to raise the load voltage to the point where the Sense input is more positive than the Threshold input ($T_{START-UP}$). Some experimentation is required if a specific minimum delay time characteristic is desired (see [Equation 7](#)).

$$C_{DELAY} = \frac{(I_{DELAY} \times T_{START-UP})}{V_{TIMER}} \quad (7)$$

In the absence of a specific delay time requirement, TI recommends a value for C_{DELAY} of 0.1 μ F.

7.3.6 Overvoltage Protection

The LM9061 remains operational with up to +26 V on V_{CC} . If V_{CC} increases to more than typically +30 V the LM9061 will turn off the MOSFET to protect the load from excessive voltage. When V_{CC} has returned to the normal operating range the device will return to normal operation without requiring toggling the ON/OFF input. This feature allows MOSFET operation to continue in applications that are subject to periodic voltage transients, such as automotive applications.

For circuits where the load is sensitive to high voltages, the circuit shown in [Figure 16](#) can be used. The addition of a Zener on the Sense input (pin 1) provides a maximum voltage reference for the Protection Comparator. The Sense resistor is required in this application to limit the Zener current. When the device is ON, and the load supply attempts to rise higher than $(V_{ZENER} + V_{THRESHOLD})$, the Protection comparator trips, and the Delay Timer starts. If the high supply voltage condition lasts long enough for the Delay Timer to time out, the MOSFET is latched off. The ON/OFF input must be toggled to restart the MOSFET.

Feature Description (continued)

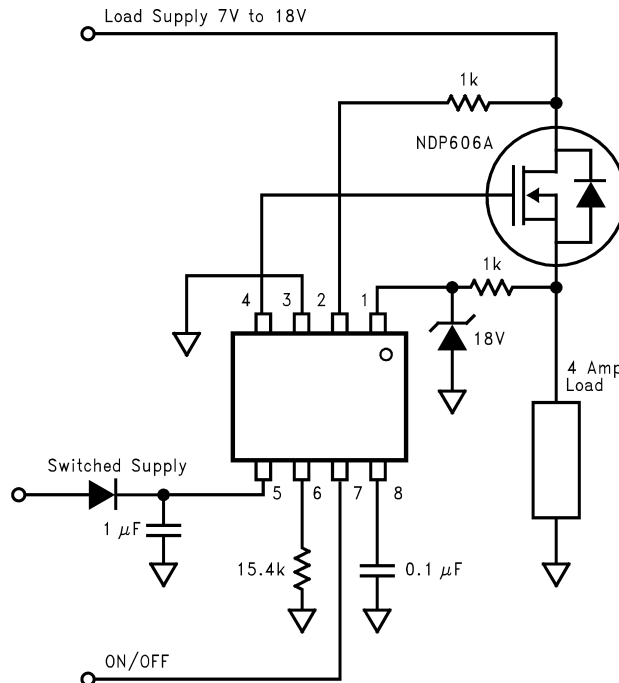

Figure 16. Adding Overvoltage Protection

7.3.7 Reverse Battery

If the V_{CC} supply must be taken negative with respect to ground, the current from the V_{CC} pin must be limited to 20 mA. The addition of a diode in series with the V_{CC} input is recommended. This diode drop does not subtract significantly from the charge pump gate overdrive output voltage.

7.3.8 Low Battery

An additional feature of the LM9061 is an Undervoltage Shutoff function (UVSO). The typical UVSO threshold is 6.2 V, and does not have hysteresis. When V_{CC} is between the ensured minimum operating voltage of 7 V, and the UVSO threshold, the operation of the MOSFET gate drive, the delay timer, and the protection circuitry is not ensured. Operation in this region must be avoided. When V_{CC} falls below the UVSO threshold, the charge pump is disabled and the gate is discharged at the normal OFF current sink rate, typically 110 μ A.

Figure 17 shows the LM9061 used as an electronic circuit breaker. This circuit provides low voltage shutdown, overvoltage latch-OFF, and overcurrent latch-OFF.

The low voltage shutdown uses the ON and OFF voltage thresholds, and the typical 1.2 V of hysteresis, to disable the LM9061 if V_{CC} falls near, or below, the 7 V minimum operating voltage. The low voltage shutdown is accomplished with a voltage divider biased off V_{CC} . The voltage divider is formed by R1 (30 k Ω), R2 (82 k Ω), and the internal pulldown resistor of the ON/OFF pin (30 k Ω typical). In normal operation, V_{CC} is above the minimum operating voltage of 7 V, and the ON/OFF pin is biased above the OFF threshold of 1.5-V maximum (1.8-V typical). When V_{CC} falls to 7 V the ON/OFF pin voltage falls below the OFF threshold voltage and the LM9061 is turned off.

In the event of a latch-OFF shutdown, the circuit can be reset by shutting the main supply off, then back on. An optional, normally open, switch (Clear) from the ON/OFF pin to ground, allows a *push button clear* of the circuit after latching OFF.

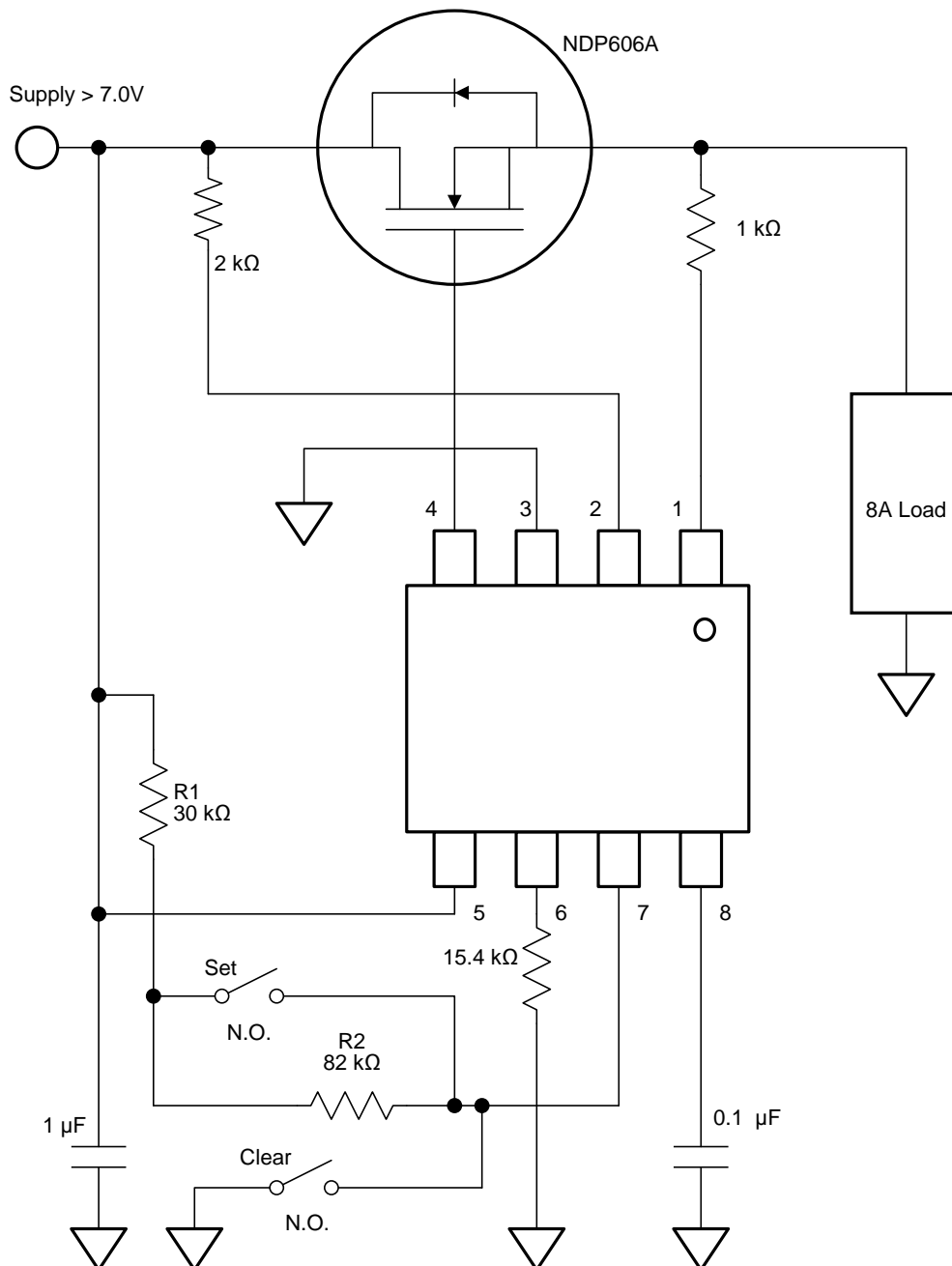
Feature Description (continued)

Figure 17. Electronic Circuit Breaker

This voltage divider arrangement requires a mechanism to raise the ON/OFF pin above the ON threshold of 3.5-V minimum (3.1-V typical) when V_{CC} is less than typically 16 V. This can be accomplished with a second, normally open, switch from the ON/OFF pin across R2 (Set), so that closing the switch shorts R2 and the voltage at the ON/OFF pin is typically one-half of V_{CC} . When V_{CC} is at the minimum operating voltage of 7 V this biases the ON/OFF pin to about 3.5 V, causing the LM9061 to turn on. When V_{CC} is above typically 16.5 V, the resistor divider has the ON/OFF pin biased above 3.5 V and shorting of the resistor R2 is not needed.

While the scaling of the external resistor values between V_{CC} and the ON/OFF input pin, against the internal 30-kΩ resistor, can be used to increase the start-up voltage, it is important that the resistor ratio always has the ON/OFF pin biased below the OFF threshold (1.5 V) when V_{CC} falls below the minimum operating voltage of 7 V.

Feature Description (continued)

The accuracy of this voltage divider arrangement is affected by normal manufacturing variations of the ON and OFF voltage thresholds and the value of internal resistor at the ON/OFF pin. If any application needs to detect with greater precision when V_{CC} is near to 7 V, an external voltage monitor must be used to drive the ON/OFF pin. The external voltage monitor would also eliminate both the need for the switch to short R2 to start the LM9061, as well as R2.

7.3.9 Increasing MOSFET Turnon Time

The ability of the LM9061 to quickly turn on the MOSFET is an important factor in the management of the MOSFET power dissipation. Exercise caution when trying to increase the MOSFET turnon time by limiting the Gate drive current. The MOSFET average dissipation, and the LM9061 Delay time, must be recalculated with the extended switching transition time.

Figure 18 shows a method of increasing the MOSFET turnon time, without affecting the turnoff time. In this method the Gate is charged at an exponential rate set by the added external Gate resistor and the MOSFET Gate capacitances.

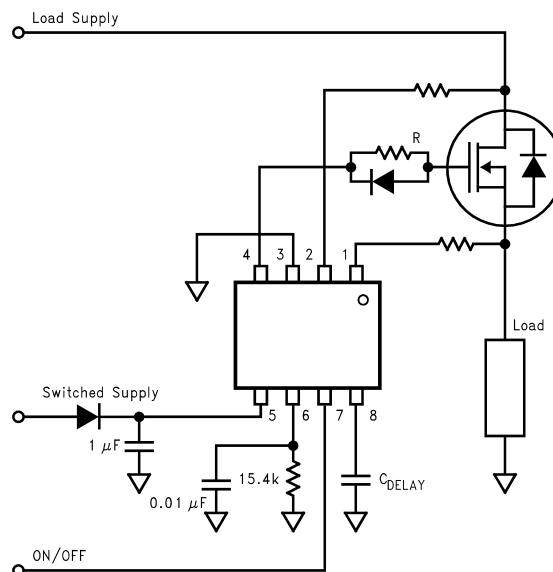

Figure 18. Increasing MOSFET Turnon Time

7.4 Device Functional Modes

7.4.1 Operation With $V_{CC} > 30\text{ V}$

If V_{CC} increases to more than typically 30 V, the LM9061 turns off the MOSFET to protect the load from excessive voltage. When V_{CC} has returned to the normal operating range, the device returns to normal operation without requiring toggling the ON/OFF input. This feature allows MOSFET operation to continue in applications that are subject to periodic voltage transients, such as automotive applications.

7.4.2 Operation With $V_{CC} < 6.2\text{ V}$

When V_{CC} falls below the UVSO threshold of 6.2 V, the charge pump is disabled and the gate is discharged at the normal OFF current sink rate, typically 110 μA .

7.4.3 Operation With ON/OFF Control

In the ON state, the charge pump voltage, which is well above the available V_{CC} supply, is directly applied to the gate of the MOSFET. When commanded OFF a 110- μA current sink discharges the gate capacitances of the MOSFET for a gradual turnoff characteristic to minimize the duration of inductive load transient voltages and further protect the power MOSFET.

7.4.4 MOSFET Latch-OFF

In the event of excessive power dissipation in the MOSFET as detected by the LM9061 sense and threshold pins, the MOSFET is latched OFF to prevent permanent failure. It does not restart until the ON/OFF Input is toggled low then high.

8 Application and Implementation

NOTE

Information in the following applications sections is not part of the TI component specification, and TI does not warrant its accuracy or completeness. TI's customers are responsible for determining suitability of components for their purposes. Customers should validate and test their design implementation to confirm system functionality.

8.1 Application Information

The LM9061 can be configured to drive the gate to any size external high-side power MOSFET, including multiple parallel connected MOSFETs for very high current applications. See [Basic Operation](#) for details on the gate drive operation and [Turn On and Turn Off Characteristics](#) for details on the gate drive timing characteristics.

8.2 Typical Applications

8.2.1 TITLE NEEDED

The LM9061 is an ideal driver for any application that requires multiple parallel MOSFETs to provide the necessary load current. [Figure 19](#) shows a circuit with four parallel NDP706A MOSFETs. This circuit configuration provides a typical maximum load current of 150 A at 25°C, and a typical maximum load current of 100 A at 125°C.

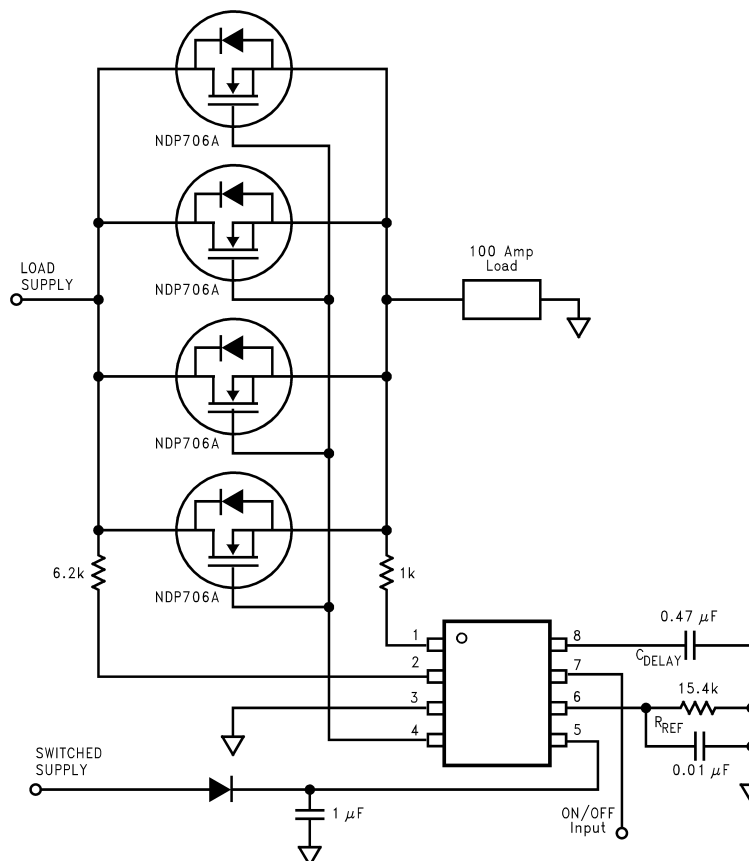

Figure 19. Driving Multiple MOSFETs

Typical Applications (continued)

8.2.1.1 Design Requirements

Only a few *common sense* precautions need to be observed. All MOSFETs in the array must have identical electrical and thermal characteristics. This can be solved by using the same part number from the same manufacturer for all of the MOSFETs in the array. Also, all MOSFETs must have the same style heat sink or, ideally, all mounted on the same heat sink. The electrical connection of the MOSFETs should get special attention. With typical $R_{DS(ON)}$ values in the range of tens of $m\Omega$, a poor electrical connection for one of the MOSFETs can render it useless in the circuit. Also, consider the MOSFET dissipation during the normal OFF discharge of the gate capacitance (70- μ A minimum and 110- μ A typical).

CAUTION

In the event of a fault condition, the Latch-OFF current sink, 10- μ A typical, may not be able to discharge the total gate capacitance in a timely manner to prevent damage to the MOSFETs.

8.2.1.2 Detailed Design Procedure

The NDP706A MOSFET has a typical $R_{DS(ON)}$ of 0.013 Ω with a T_J of 25°C, and 0.02 Ω with a T_J of +125°C. An $R_{THRESHOLD}$ value of 6.2 k Ω as shown in [Figure 19](#) sets the V_{DS} threshold voltage to approximately 500 mV. This provides a typical maximum load current of 150 A at 25°C, and a typical maximum load current of 100 A at 125°C. See [Lossless Overcurrent Protection](#) for details on calculating $R_{THRESHOLD}$.

The maximum dissipation, per MOSFET, is nearly 20 W at 25°C, and 12.5 W at 125°C. With up to 20 W being dissipated by each of the four devices, an effective heat sink is required to keep the T_J as low as possible when operating near the maximum load currents.

8.2.1.3 Application Curves

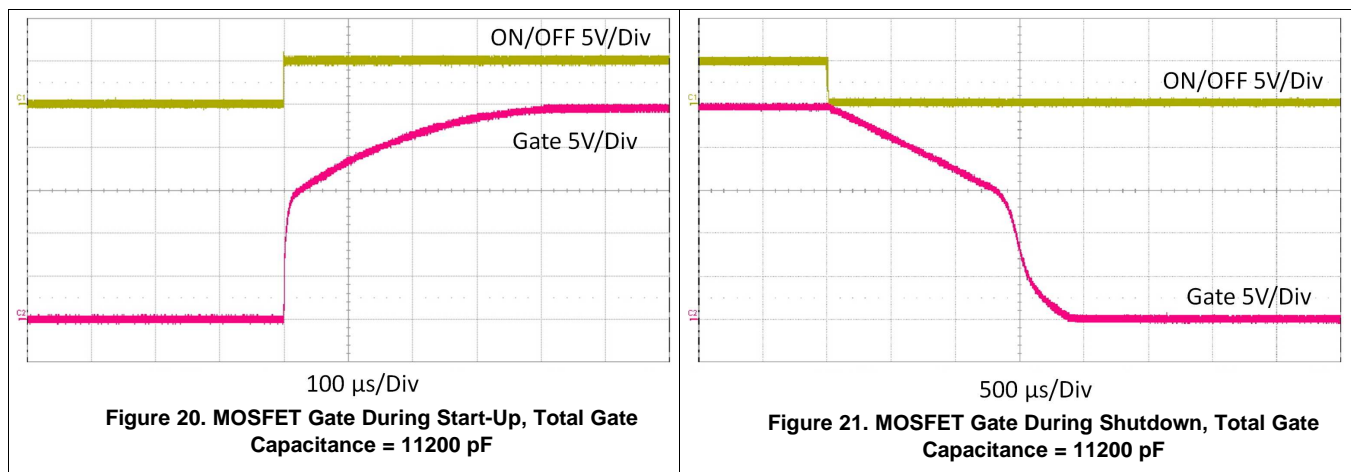

Typical Applications (continued)

8.2.2 Bidirectional Applications

8.2.2.1 Back-to-Back MOSFET Configuration

Due to the orientation of the FET, the typical configuration of LM9061 is only able to toggle conduction when current flows from the drain to the source. In applications where reverse current may occur, the body diode always provides a path from load to supply. For the LM9061's OFF state to fully disconnect the load and supply and prevent any bidirectional current, an additional FET must be placed in series with the original. This back-to-back configuration shown in Figure 22 allows either input to be the supply side or the load side.

NOTE

An increase in turnon and turnoff time occurs due to the increased gate capacitance from the additional FET.

To provide the LM9061 with proper supply voltage, two diodes connect both inputs to V_{CC} . This feeds the device with whichever side has a higher potential, ensuring that it does not disconnect itself from the voltage supply during operation.

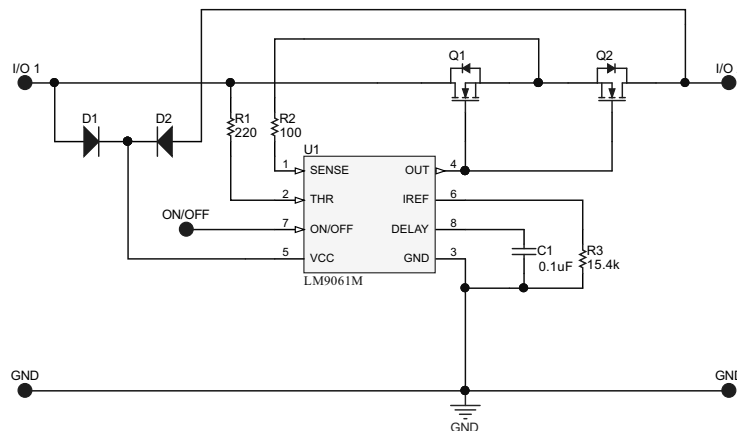

Copyright © 2016, Texas Instruments Incorporated

Figure 22. Bidirectional Switch

8.2.2.1.1 Application Curve

Here the bidirectional switch is being used to charge and discharge a capacitive load. As long as the switch is enabled ON, current is allowed to flow in and out of the capacitor in response to the steps in input voltage. However, when the switch is enabled OFF, current ceases to flow and the capacitor voltage is isolated from the input. Operation continues normally once the switch is returned to an ON state.

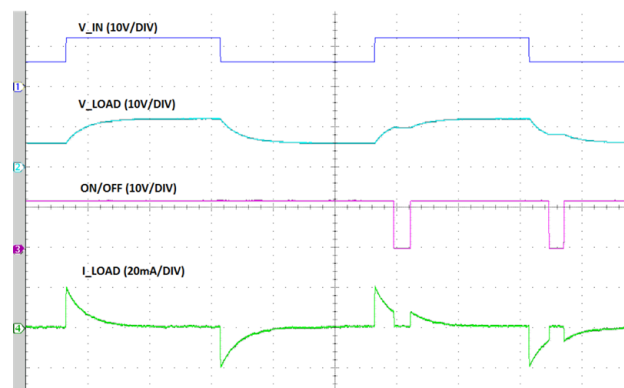
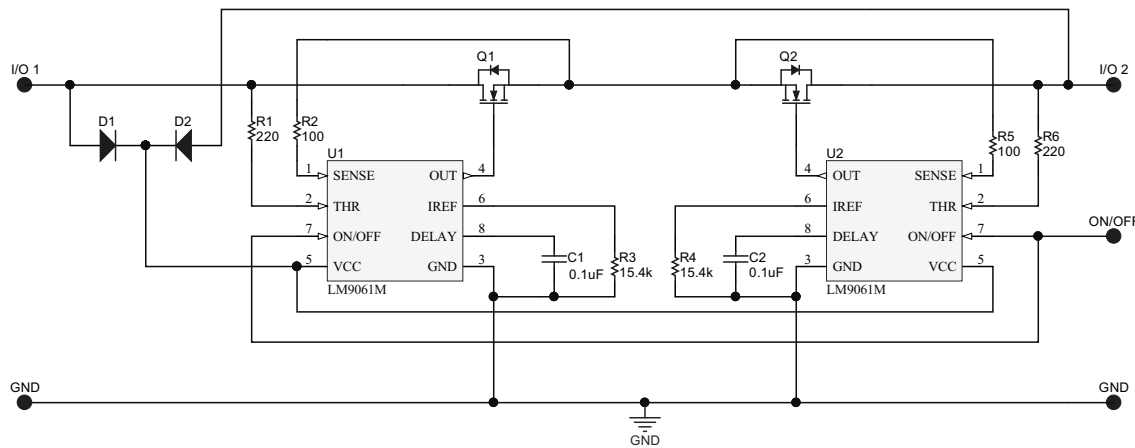

Figure 23. Bidirectional Switch Controlling Current to a Capacitive Load

Typical Applications (continued)

8.2.2.2 Bidirectional Switch With Reverse Overcurrent Protection

While Figure 22 functions as a bidirectional switch, it does not monitor for overcurrent in both directions. Because overcurrent is detected when the potential at the sense pin is lower than the potential at the threshold pin by a user set amount, the LM9061 only offers OCP when the current flows through the FET before reaching the sense pin. To implement a bidirectional switch that also has bidirectional overcurrent protection, each FET should be controlled by its own LM9061 device. Figure 24 shows the two LM9061 and FET pairs in a mirrored back-to-back configuration. By tying the ON/OFF pins together, the switch can still be toggled from a single line.



Copyright © 2016, Texas Instruments Incorporated

Figure 24. Bidirectional Switch Including Reverse OCP

8.2.2.2.1 Application Curve

The application curve below shows the reverse overcurrent protection. Even with the bidirectional current, the device goes into overcurrent shutdown if the current reaches the current limit threshold. Note that the reverse overcurrent protection is accomplished using two separate LM9061 devices as shown in Figure 24.

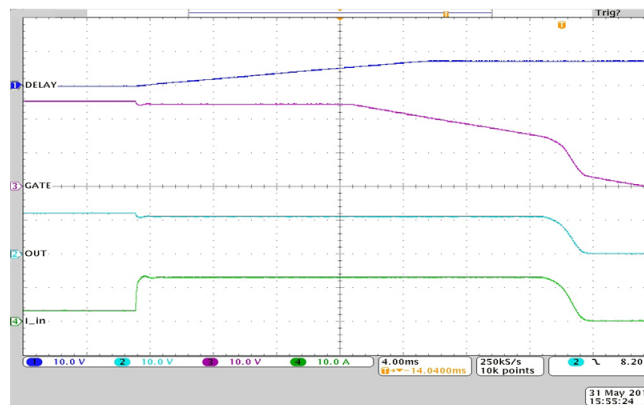

Figure 25. Reverse Overcurrent Protection for Bidirectional Switch

9 Power Supply Recommendations

It is important to remember that during the Turnon of the MOSFET the output current to the Gate is drawn from the V_{CC} supply pin. The V_{CC} pin must be bypassed with a capacitor with a value of at least ten times the Gate capacitance, and no less than 0.1 μF . If the V_{CC} supply must be taken negative with respect to ground, for example during a reverse battery condition, the current from the V_{CC} pin must be limited to 20 mA. The addition of a diode in series with the V_{CC} input is recommended. This diode drop does not subtract significantly from the charge pump gate overdrive output voltage.

10 Layout

10.1 Layout Guidelines

1. The bypass capacitor for V_{CC} must be placed as close as possible to the V_{CC} pin.
2. The resistor R_{REF} must be placed as close as possible to the I_{REF} and Ground pins with minimal trace length to keep the I_{REF} current as accurate as possible. The LM9061 is optimized for use with a $15.4\text{ k}\Omega \pm 1\%$ resistor for R_{REF} .
3. In applications where the V_{CC} supply is subject to high levels of transient noise, a bypass capacitor across R_{REF} is recommended. This bypass capacitor must be no larger than $0.1\text{ }\mu\text{F}$ and must be placed as close as possible to the I_{REF} pin.
4. The $R_{THRESHOLD}$ and R_{SENSE} resistors must be placed as close as possible to the MOSFET drain and source pins respectively. This allows accurate monitoring of the V_{DS} voltage across the MOSFET.
5. An array of vias can be placed along the high current path to the output load. These vias can help conduct heat to any inner plane areas or to a bottom-side copper plane.

10.2 Layout Examples

Figure 26 and Figure 27 are layout examples for the LM9061 and LM9061-Q1. These examples are taken from the LM9061EVM. For information on the operation and schematic of the EVM, see [LM9061 High-Side Protection Controller EVM](#) (SNOU132).

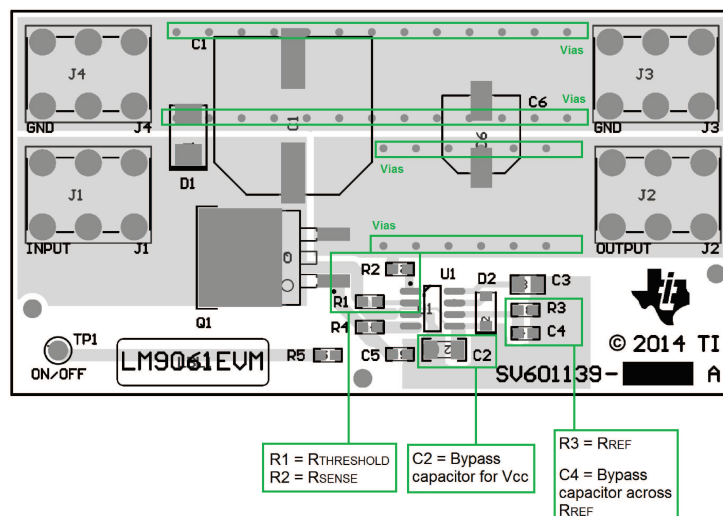

Figure 26. LM9061EVM Layout Example (Top)

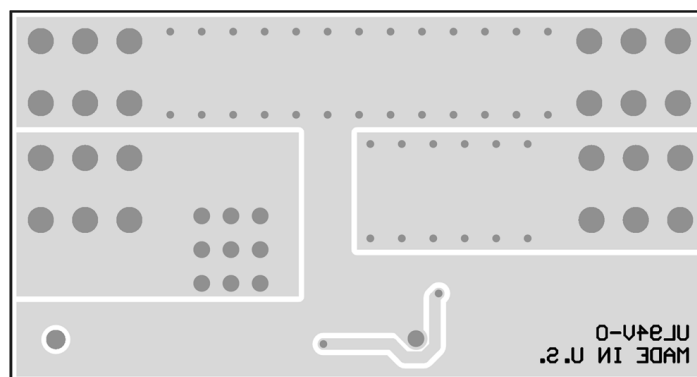

Figure 27. LM9061EVM Layout Example (Bottom)

11 Device and Documentation Support

11.1 Documentation Support

11.1.1 Related Documentation

For related documentation, see the following:

[LM9061 High-Side Protection Controller EVM \(SNOU132\)](#)

11.2 Related Links

The table below lists quick access links. Categories include technical documents, support and community resources, tools and software, and quick access to sample or buy.

Table 1. Related Links

PARTS	PRODUCT FOLDER	SAMPLE & BUY	TECHNICAL DOCUMENTS	TOOLS & SOFTWARE	SUPPORT & COMMUNITY
LM9061	Click here	Click here	Click here	Click here	Click here
LM9061-Q1	Click here	Click here	Click here	Click here	Click here

11.3 Receiving Notification of Documentation Updates

To receive notification of documentation updates, navigate to the device product folder on ti.com. In the upper right corner, click on *Alert me* to register and receive a weekly digest of any product information that has changed. For change details, review the revision history included in any revised document.

11.4 Community Resources

The following links connect to TI community resources. Linked contents are provided "AS IS" by the respective contributors. They do not constitute TI specifications and do not necessarily reflect TI's views; see TI's [Terms of Use](#).

TI E2E™ Online Community *TI's Engineer-to-Engineer (E2E) Community*. Created to foster collaboration among engineers. At e2e.ti.com, you can ask questions, share knowledge, explore ideas and help solve problems with fellow engineers.

Design Support *TI's Design Support* Quickly find helpful E2E forums along with design support tools and contact information for technical support.

11.5 Trademarks

E2E is a trademark of Texas Instruments.

All other trademarks are the property of their respective owners.

11.6 Electrostatic Discharge Caution



These devices have limited built-in ESD protection. The leads should be shorted together or the device placed in conductive foam during storage or handling to prevent electrostatic damage to the MOS gates.

11.7 Glossary

[SLYZ022](#) — *TI Glossary*.

This glossary lists and explains terms, acronyms, and definitions.

12 Mechanical, Packaging, and Orderable Information

The following pages include mechanical, packaging, and orderable information. This information is the most current data available for the designated devices. This data is subject to change without notice and revision of this document. For browser-based versions of this data sheet, refer to the left-hand navigation.

PACKAGING INFORMATION

Orderable Device	Status (1)	Package Type	Package Drawing	Pins	Package Qty	Eco Plan (2)	Lead/Ball Finish (6)	MSL Peak Temp (3)	Op Temp (°C)	Device Marking (4/5)	Samples
LM9061M/NOPB	ACTIVE	SOIC	D	8	95	Green (RoHS & no Sb/Br)	CU SN	Level-1-260C-UNLIM	-40 to 125	LM90 61M	Samples
LM9061MX/NOPB	ACTIVE	SOIC	D	8	2500	Green (RoHS & no Sb/Br)	CU SN	Level-1-260C-UNLIM	-40 to 125	LM90 61M	Samples
LM9061QDRQ1	ACTIVE	SOIC	D	8	2500	Green (RoHS & no Sb/Br)	CU NIPDAU	Level-3-260C-168HRS	-40 to 125	9061Q1	Samples

(1) The marketing status values are defined as follows:

ACTIVE: Product device recommended for new designs.

LIFEBUY: TI has announced that the device will be discontinued, and a lifetime-buy period is in effect.

NRND: Not recommended for new designs. Device is in production to support existing customers, but TI does not recommend using this part in a new design.

PREVIEW: Device has been announced but is not in production. Samples may or may not be available.

OBsolete: TI has discontinued the production of the device.

(2) Eco Plan - The planned eco-friendly classification: Pb-Free (RoHS), Pb-Free (RoHS Exempt), or Green (RoHS & no Sb/Br) - please check <http://www.ti.com/productcontent> for the latest availability information and additional product content details.

TBD: The Pb-Free/Green conversion plan has not been defined.

Pb-Free (RoHS): TI's terms "Lead-Free" or "Pb-Free" mean semiconductor products that are compatible with the current RoHS requirements for all 6 substances, including the requirement that lead not exceed 0.1% by weight in homogeneous materials. Where designed to be soldered at high temperatures, TI Pb-Free products are suitable for use in specified lead-free processes.

Pb-Free (RoHS Exempt): This component has a RoHS exemption for either 1) lead-based flip-chip solder bumps used between the die and package, or 2) lead-based die adhesive used between the die and leadframe. The component is otherwise considered Pb-Free (RoHS compatible) as defined above.

Green (RoHS & no Sb/Br): TI defines "Green" to mean Pb-Free (RoHS compatible), and free of Bromine (Br) and Antimony (Sb) based flame retardants (Br or Sb do not exceed 0.1% by weight in homogeneous material)

(3) MSL, Peak Temp. - The Moisture Sensitivity Level rating according to the JEDEC industry standard classifications, and peak solder temperature.

(4) There may be additional marking, which relates to the logo, the lot trace code information, or the environmental category on the device.

(5) Multiple Device Markings will be inside parentheses. Only one Device Marking contained in parentheses and separated by a "~" will appear on a device. If a line is indented then it is a continuation of the previous line and the two combined represent the entire Device Marking for that device.

(6) Lead/Ball Finish - Orderable Devices may have multiple material finish options. Finish options are separated by a vertical ruled line. Lead/Ball Finish values may wrap to two lines if the finish value exceeds the maximum column width.

Important Information and Disclaimer: The information provided on this page represents TI's knowledge and belief as of the date that it is provided. TI bases its knowledge and belief on information provided by third parties, and makes no representation or warranty as to the accuracy of such information. Efforts are underway to better integrate information from third parties. TI has taken and

continues to take reasonable steps to provide representative and accurate information but may not have conducted destructive testing or chemical analysis on incoming materials and chemicals. TI and TI suppliers consider certain information to be proprietary, and thus CAS numbers and other limited information may not be available for release.

In no event shall TI's liability arising out of such information exceed the total purchase price of the TI part(s) at issue in this document sold by TI to Customer on an annual basis.

OTHER QUALIFIED VERSIONS OF LM9061, LM9061-Q1 :

- Catalog: [LM9061](#)
- Automotive: [LM9061-Q1](#)

NOTE: Qualified Version Definitions:

- Catalog - TI's standard catalog product
- Automotive - Q100 devices qualified for high-reliability automotive applications targeting zero defects

TAPE AND REEL INFORMATION



QUADRANT ASSIGNMENTS FOR PIN 1 ORIENTATION IN TAPE



*All dimensions are nominal

Device	Package Type	Package Drawing	Pins	SPQ	Reel Diameter (mm)	Reel Width W1 (mm)	A0 (mm)	B0 (mm)	K0 (mm)	P1 (mm)	W (mm)	Pin1 Quadrant
LM9061MX/NOPB	SOIC	D	8	2500	330.0	12.4	6.5	5.4	2.0	8.0	12.0	Q1
LM9061QDRQ1	SOIC	D	8	2500	330.0	12.4	6.5	5.4	2.0	8.0	12.0	Q1

TAPE AND REEL BOX DIMENSIONS

*All dimensions are nominal

Device	Package Type	Package Drawing	Pins	SPQ	Length (mm)	Width (mm)	Height (mm)
LM9061MX/NOPB	SOIC	D	8	2500	367.0	367.0	35.0
LM9061QDRQ1	SOIC	D	8	2500	367.0	367.0	35.0



D0008A

PACKAGE OUTLINE

SOIC - 1.75 mm max height

SMALL OUTLINE INTEGRATED CIRCUIT



NOTES:

1. Linear dimensions are in inches [millimeters]. Dimensions in parenthesis are for reference only. Controlling dimensions are in inches. Dimensioning and tolerancing per ASME Y14.5M.
2. This drawing is subject to change without notice.
3. This dimension does not include mold flash, protrusions, or gate burrs. Mold flash, protrusions, or gate burrs shall not exceed $.006$ [0.15] per side.
4. This dimension does not include interlead flash.
5. Reference JEDEC registration MS-012, variation AA.

EXAMPLE BOARD LAYOUT

D0008A

SOIC - 1.75 mm max height

SMALL OUTLINE INTEGRATED CIRCUIT



LAND PATTERN EXAMPLE
EXPOSED METAL SHOWN
SCALE:8X



SOLDER MASK DETAILS

4214825/C 02/2019

NOTES: (continued)

6. Publication IPC-7351 may have alternate designs.

7. Solder mask tolerances between and around signal pads can vary based on board fabrication site.

EXAMPLE STENCIL DESIGN

D0008A

SOIC - 1.75 mm max height

SMALL OUTLINE INTEGRATED CIRCUIT



SOLDER PASTE EXAMPLE
BASED ON .005 INCH [0.125 MM] THICK STENCIL
SCALE:8X

4214825/C 02/2019

NOTES: (continued)

8. Laser cutting apertures with trapezoidal walls and rounded corners may offer better paste release. IPC-7525 may have alternate design recommendations.
9. Board assembly site may have different recommendations for stencil design.

IMPORTANT NOTICE AND DISCLAIMER

TI PROVIDES TECHNICAL AND RELIABILITY DATA (INCLUDING DATASHEETS), DESIGN RESOURCES (INCLUDING REFERENCE DESIGNS), APPLICATION OR OTHER DESIGN ADVICE, WEB TOOLS, SAFETY INFORMATION, AND OTHER RESOURCES "AS IS" AND WITH ALL FAULTS, AND DISCLAIMS ALL WARRANTIES, EXPRESS AND IMPLIED, INCLUDING WITHOUT LIMITATION ANY IMPLIED WARRANTIES OF MERCHANTABILITY, FITNESS FOR A PARTICULAR PURPOSE OR NON-INFRINGEMENT OF THIRD PARTY INTELLECTUAL PROPERTY RIGHTS.

These resources are intended for skilled developers designing with TI products. You are solely responsible for (1) selecting the appropriate TI products for your application, (2) designing, validating and testing your application, and (3) ensuring your application meets applicable standards, and any other safety, security, or other requirements. These resources are subject to change without notice. TI grants you permission to use these resources only for development of an application that uses the TI products described in the resource. Other reproduction and display of these resources is prohibited. No license is granted to any other TI intellectual property right or to any third party intellectual property right. TI disclaims responsibility for, and you will fully indemnify TI and its representatives against, any claims, damages, costs, losses, and liabilities arising out of your use of these resources.

TI's products are provided subject to TI's Terms of Sale (www.ti.com/legal/termsofsale.html) or other applicable terms available either on ti.com or provided in conjunction with such TI products. TI's provision of these resources does not expand or otherwise alter TI's applicable warranties or warranty disclaimers for TI products.

Mailing Address: Texas Instruments, Post Office Box 655303, Dallas, Texas 75265
Copyright © 2019, Texas Instruments Incorporated

Looking for pricing, stock, or lifecycle information?

Click below to explore more details on WIN SOURCE:

 [View LM9061MX/NOPB on WIN SOURCE](#)

 [Texas Instruments](#) Information

Optimize Your Supply Chain with WIN SOURCE Solutions

-  Global Sourcing Solution
-  Obsolete Management
-  Cost Control Management
-  Shortage Management
-  Alternative Solution
-  Excess Inventory Management