



THE DATASHEET OF LM71CIMFX/NOPB



LM71/LM71-Q1 SPI/MICROWIRE 13-Bit Plus Sign Temperature Sensor

1 Features

- LM71Q is AEC-Q100 Grade 0 Qualified and is Manufactured on an Automotive Grade Flow
- 5-Pin SOT-23 Package or 6-Pin No-Pull-Back WSON Package
- Operates Over a Full -40°C to $+150^{\circ}\text{C}$ Range
- SPI and MICROWIRE Bus Interface
- Key Specifications:
 - Supply Voltage: 2.65V to 5.5V
 - Supply Current
 - Operating: 300 μA (typ)
 - 550 μA (max)
 - Temperature Accuracy
 - -10°C to $+65^{\circ}\text{C}$: $\pm 1.5^{\circ}\text{C}$ (max)
 - -40°C to 150°C : $+3/- 2^{\circ}\text{C}$ (max)
 - Temperature Resolution: 31.25 m°C

2 Applications

- System Thermal Management
- Personal Computers
- Portable Electronic Devices
- Disk Drives
- Office Electronics
- Electronic Test Equipment
- Vending Machines
- Automotive

3 Description

The LM71 is a low-power, high-resolution digital temperature sensor with an SPI and MICROWIRE compatible interface, available in the 5-pin SOT-23 or the 6-pin WSON (no pull back) package. The host can query the LM71 at any time to read temperature. Its low operating current is useful in systems where low power consumption is critical.

The LM71 has 13-bit plus sign temperature resolution (0.03125 $^{\circ}\text{C}$ per LSB) while operating over a temperature range of -40°C to $+150^{\circ}\text{C}$.

The LM71's 2.65V to 5.5V supply voltage range, fast conversion rate, low supply current, and simple SPI interface make it ideal for a wide range of applications. The LM71Q is available in the 5-lead SOT-23 package only.

Simplified Block Diagram

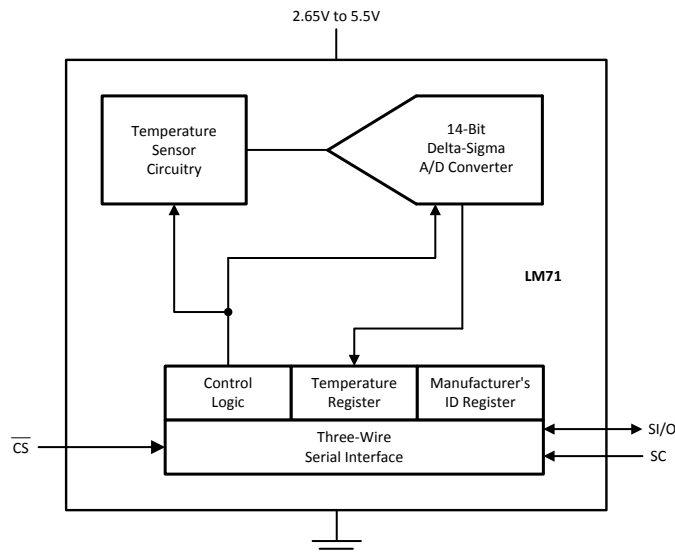

3.1 Connection Diagram

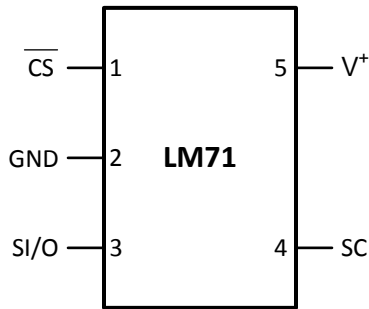

Figure 1. 5-Pin SOT-23
See Package Number DBV

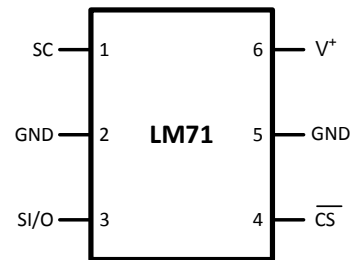

Figure 2. 6-Pin WSON No Pull-Back
See Package Number NGG0006A

Table 1. PIN DESCRIPTIONS

Label	Pin Number		Function	Typical Connection
	SOT-23-5	WSON-6		
$\overline{\text{CS}}$	1	4	Chip Select input	From controller
GND	2	2, 5	Power Supply Ground	Connect all GND Pins to ground
SI/O	3	3	Slave Input/Output - Serial bus bi-directional data line. Schmitt trigger input.	From and to controller
SC	4	1	Slave Clock - Serial bus clock Schmitt trigger input line	From controller
V ⁺	5	6	Positive Supply Voltage Input	DC voltage from 2.65V to 5.5V. Bypass with a 0.1 μF ceramic capacitor.

3.2 Typical Application

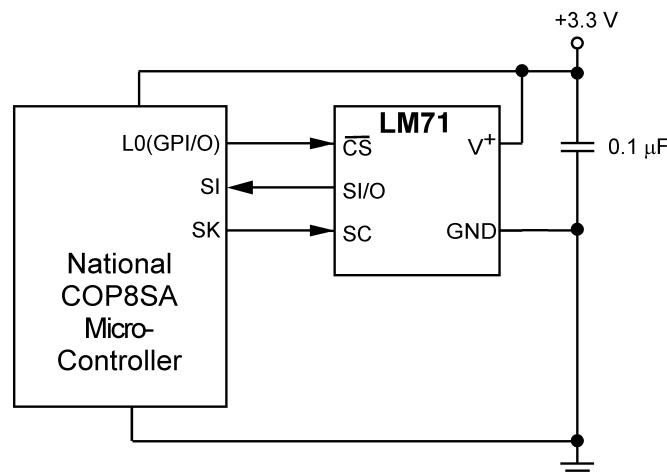

Figure 3. COP Microcontroller Interface

3.1 Electrostatic Discharge Caution



These devices have limited built-in ESD protection. The leads should be shorted together or the device placed in conductive foam during storage or handling to prevent electrostatic damage to the MOS gates.

3.2 Trademarks

All trademarks are the property of their respective owners.

4 Absolute Maximum Ratings⁽¹⁾

Supply Voltage		-0.3V to 6.0V
Voltage at any Pin		-0.3V to V ⁺ + 0.3V
Input Current at any Pin ⁽²⁾		5 mA
Storage Temperature		-65°C to +150°C
Soldering Information, Lead Temperature	SOT-23-5 Package	Vapor Phase (60 seconds) 215°C
		Infrared (15 seconds) 220°C
	WSON-6 Package	Infrared (5 seconds) 215°C
ESD Susceptibility ⁽³⁾	Human Body Model	2000V
	Machine Model	200V

(1) Absolute Maximum Ratings indicate limits beyond which damage to the device may occur. DC and AC electrical specifications do not apply when operating the device beyond its rated operating conditions.

(2) When the input voltage (V_I) at any pin exceeds the power supplies (V_I < GND or V_I > +V_S) the current at that pin should be limited to 5 mA.

(3) Human body model, 100 pF discharged through a 1.5 kΩ resistor. Machine model, 200 pF discharged directly into each pin.

5 Operating Ratings

Specified Temperature Range ⁽¹⁾ (T _{MIN} to T _{MAX})	LM71CIMF, LM71CISD, LM71QCIMF	-40°C to +150°C
Supply Voltage Range (+V _S)	LM71CIMF, LM71CISD, LM71QCIMF	+2.65V to +5.5V

(1) The life expectancy of the LM71 will be reduced when operating at elevated temperatures. LM71 θ_{JA} (thermal resistance, junction-to-ambient) when attached to a printed circuit board with 2 oz. foil is summarized in the table below:

Device Number	Thermal Resistance (θ_{JA})
LM71CIMF/LM71QCIMF	250°C/W
LM71CISD	57.6°C/W

6 Temperature-to-Digital Converter Characteristics

Unless otherwise noted, these specifications apply for $V^+ = 2.65V$ to $3.6V^{(1)}$. **Boldface limits apply for $T_A = T_J = T_{MIN}$ to T_{MAX}** ; all other limits $T_A = T_J = +25^\circ C$, unless otherwise noted.

Parameter	Conditions	Typical ⁽²⁾	LM71CIMF LM71CISD Limits ⁽³⁾	Units (Limit)
Temperature Error ⁽¹⁾⁽⁴⁾	$T_A = -10^\circ C$ to $+65^\circ C$		± 1.5	$^\circ C$ (max)
	$T_A = -40^\circ C$ to $+85^\circ C$		± 2.0	$^\circ C$ (max)
	$T_A = -40^\circ C$ to $+150^\circ C$		$+3/-2$	$^\circ C$ (max)
Resolution		14 0.03125		Bits $^\circ C$
Temperature Conversion Time	See ⁽⁵⁾	200	270	ms (max)
Quiescent Current	Serial Bus Inactive	300	550	μA (max)

- (1) The LM71 will operate properly over the V^+ supply voltage range of 2.65V to 5.5V.
- (2) Typicals are at $T_A = 25^\circ C$ and represent most likely parametric norm.
- (3) Limits are ensured to AOQL (Average Outgoing Quality Level).
- (4) For best accuracy, minimize output loading. Higher sink currents can affect sensor accuracy with internal heating. This can cause an error of $0.64^\circ C$ at full rated sink current and saturation voltage based on junction-to-ambient thermal resistance.
- (5) Following a power on reset, the user must allow at least 270 ms before making the first read transaction to ensure a first valid temperature read. After the first read, in order to ensure an accurate temperature result, the time interval between any two consecutive temperature reads must be greater than the maximum conversion time of 270 ms. For more information, refer to [SNLA296](#).

7 Logic Electrical Characteristics

DIGITAL DC CHARACTERISTICS

Unless otherwise noted, these specifications apply for $V^+ = 2.65V$ to $3.6V^{(1)}$. **Boldface limits apply for $T_A = T_J = T_{MIN}$ to T_{MAX}** ; all other limits $T_A = T_J = +25^\circ C$, unless otherwise noted.

Symbol	Parameter	Conditions	Typical ⁽²⁾	Limits ⁽³⁾	Units (Limit)
$V_{IN(1)}$	Logical "1" Input Voltage			$V^+ \times 0.7$	V (min)
				$V^+ + 0.3$	V (max)
$V_{IN(0)}$	Logical "0" Input Voltage			-0.3	V (min)
				$V^+ \times 0.3$	V (max)
	Input Hysteresis Voltage	$V^+ = 3.0V$ to $3.6V$	0.4	0.33	V (min)
$I_{IN(1)}$	Logical "1" Input Current	$V_{IN} = V^+$	0.005	3.0	μA (max)
$I_{IN(0)}$	Logical "0" Input Current	$V_{IN} = 0V$	-0.005	-3.0	μA (min)
C_{IN}	All Digital Inputs		20		pF
V_{OH}	High Level Output Voltage	$I_{OH} = -400 \mu A$		2.4	V (min)
V_{OL}	Low Level Output Voltage	$I_{OL} = +2 mA$		0.4	V (max)
$I_{O_TRI-STATE}$	TRI-STATE Output Leakage Current	$V_O = GND$ $V_O = V^+$		-1	μA (min)
				+1	μA (max)

- (1) The LM71 will operate properly over the V^+ supply voltage range of 2.65V to 5.5V.
- (2) Typicals are at $T_A = 25^\circ C$ and represent most likely parametric norm.
- (3) Limits are ensured to AOQL (Average Outgoing Quality Level).

SERIAL BUS DIGITAL SWITCHING CHARACTERISTICS

Unless otherwise noted, these specifications apply for $V^+ = 2.65\text{V}$ to $3.6\text{V}^{(1)}$; C_L (load capacitance) on output lines = 100 pF unless otherwise specified. **Boldface limits apply for $T_A = T_J = T_{\text{MIN}}$ to T_{MAX}** ; all other limits $T_A = T_J = +25^\circ\text{C}$, unless otherwise noted.

Symbol	Parameter	Conditions	Typical ⁽²⁾	Limits ⁽³⁾	Units (Limit)
t_1	SC (Clock) Period			0.16 DC	μs (min) (max)
t_2	$\overline{\text{CS}}$ Low to SC (Clock) High Set-Up Time			100	ns (min)
t_3	$\overline{\text{CS}}$ Low to Data Out (SO) Delay			70	ns (max)
t_4	SC (Clock) Low to Data Out (SO) Delay			70	ns (max)
t_5	$\overline{\text{CS}}$ High to Data Out (SO) TRI-STATE			200	ns (max)
t_6	SC (Clock) High to Data In (SI) Hold Time			50	ns (min)
t_7	Data In (SI) Set-Up Time to SC (Clock) High			30	ns (min)
t_r	SC (Clock) Rise Time			100	ns (max)
t_f	SC (Clock) Fall Time			100	ns (max)

(1) The LM71 will operate properly over the V^+ supply voltage range of 2.65V to 5.5V.

(2) Typicals are at $T_A = 25^\circ\text{C}$ and represent most likely parametric norm.

(3) Limits are ensured to AOQL (Average Outgoing Quality Level).

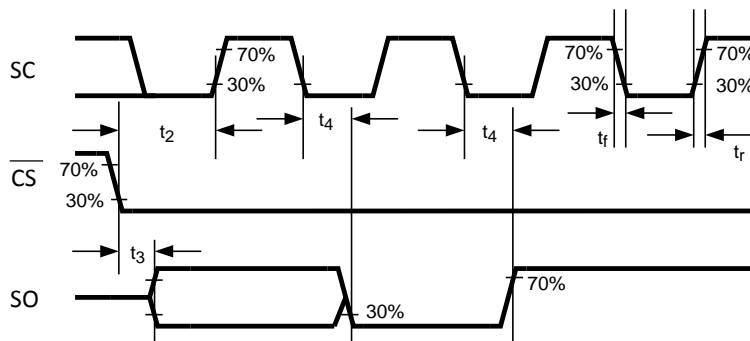

Figure 4. Data Output Timing Diagram

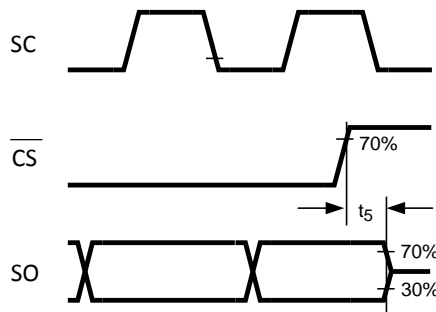

Figure 5. TRI-STATE Data Output Timing Diagram

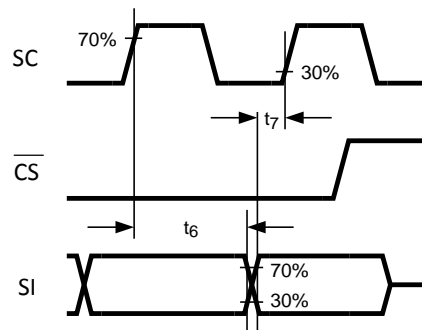

Figure 6. Data Input Timing Diagram

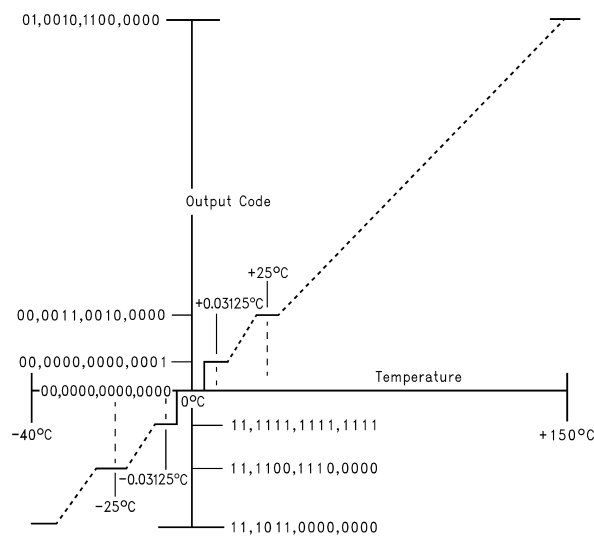

Figure 7. Temperature-to-Digital Transfer Function (Non-linear scale for clarity)

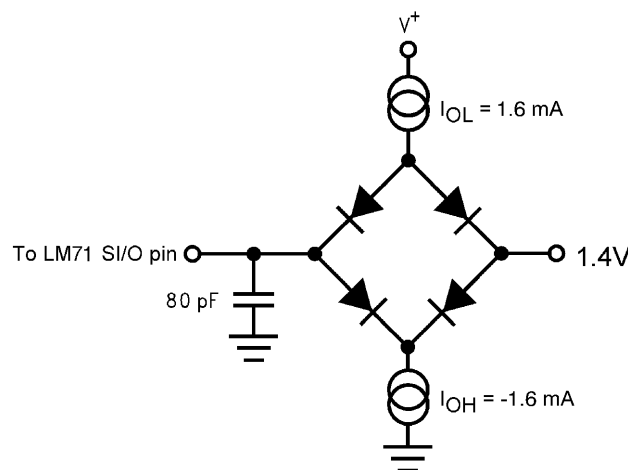
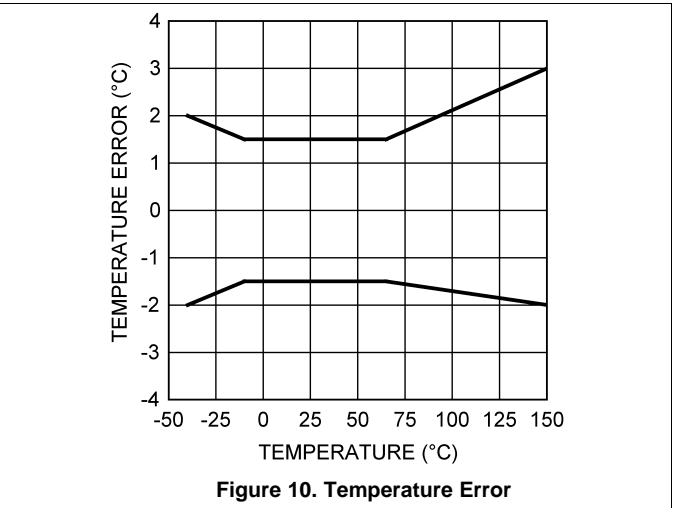
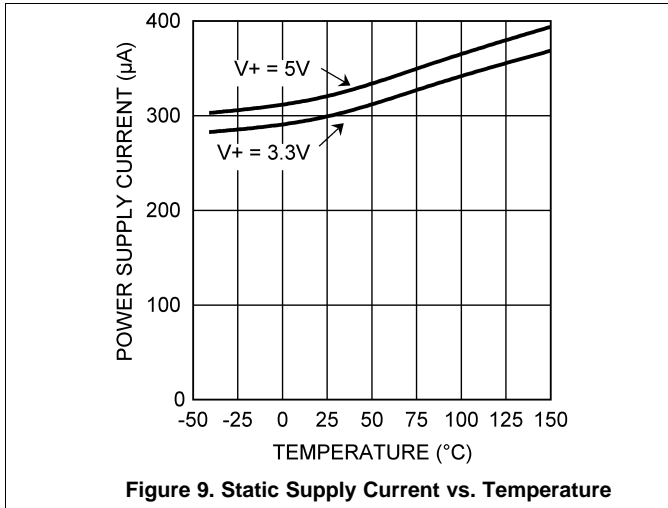

Figure 8. TRI-STATE Test Circuit

8 Typical Performance Characteristics



9 Functional Description

The LM71 temperature sensor incorporates a temperature sensor and 13-bit plus sign $\Delta\Sigma$ ADC (Delta-Sigma Analog-to-Digital Converter). Compatibility of the LM71's three wire serial interface with SPI and MICROWIRE allows simple communications with common microcontrollers and processors. Shutdown mode can be used to optimize current drain for different applications. A Manufacture's/Device ID register identifies the LM71 as TI product.

9.1 POWER UP AND POWER DOWN

The LM71 always powers up in a known state. The power up default condition is continuous conversion mode. Immediately after power up the LM71 will output an erroneous code until the first temperature conversion has completed.

When the supply voltage is less than about 1.6V (typical), the LM71 is considered powered down. As the supply voltage rises above the nominal 1.6V power up threshold, the internal registers are reset to the power up default state described above.

9.2 SERIAL BUS INTERFACE

The LM71 operates as a slave and is compatible with SPI or MICROWIRE bus specifications. Data is clocked out on the falling edge of the serial clock (SC), while data is clocked in on the rising edge of SC. A complete transmit/receive communication will consist of 32 serial clocks. The first 16 clocks comprise the transmit phase of communication, while the second 16 clocks are the receive phase.

When \overline{CS} is high SI/O will be in TRI-STATE. Communication should be initiated by taking chip select (\overline{CS}) low. This should not be done when SC is changing from a low to high state. Once \overline{CS} is low the serial I/O pin (SI/O) will transmit the first bit of data. The master can then read this bit with the rising edge of SC. The remainder of the data will be clocked out by the falling edge of SC. \overline{CS} can be taken high at any time during the transmit phase. If \overline{CS} is brought low in the middle of a conversion the LM71 will complete the conversion and the output shift register will be updated after \overline{CS} is brought back high.

The receive phase of a communication starts after 16 SC periods. \overline{CS} can remain low for 32 SC cycles. The LM71 will read the data available on the SI/O line on the rising edge of the serial clock. Input data is to an 8-bit shift register. The part will detect the last eight bits shifted into the register. The receive phase can last up to 16 SC periods. All ones must be shifted in order to place the part into shutdown. All zeros must be shifted in order to place the LM71 into continuous conversion mode. Only the following codes should be transmitted to the LM71:

- 00 hex for continuous conversion
- FF hex for shutdown

Another code may place the part into a test mode. Test modes are used by TI to thoroughly test the function of the LM71 during production testing. Only eight bits have been defined above since only the last eight transmitted are detected by the LM71, before \overline{CS} is taken HIGH.

The following communication can be used to determine the Manufacture's/Device ID and then immediately place the part into continuous conversion mode. With \overline{CS} continuously low:

- Read 16 bits of temperature data
- Write 16 bits of data commanding shutdown
- Read 16 bits of Manufacture's/Device ID data
- Write 8 to 16 bits of data commanding Conversion Mode
- Take \overline{CS} HIGH.

Note that 300 ms will have to pass for a conversion to complete before the LM71 actually transmits temperature data.

9.3 TEMPERATURE DATA FORMAT

Temperature data is represented by a 14-bit, two's complement word with an LSB (Least Significant Bit) equal to 0.03125°C:

Temperature	Digital Output	
	Binary	Hex
+150°C	0100 1011 0000 0011	4B03
+125°C	0011 1110 1000 0011	3E83
+25°C	0000 1100 1000 0011	0C83
+0.03125°C	0000 0000 0000 0111	0007
0°C	0000 0000 0000 0011	0003
-0.03125°C	1111 1111 1111 1111	FFFF
-25°C	1111 0011 1000 0011	F383
-40°C	1110 1100 0000 0011	EC03

The first data byte is the most significant byte with most significant bit first, permitting only as much data as necessary to be read to determine temperature condition. For instance, if the first four bits of the temperature data indicate an overtemperature condition, the host processor could immediately take action to remedy the excessive temperatures.

9.4 SHUTDOWN MODE/MANUFACTURER'S ID

Shutdown mode is enabled by writing XX FF to the LM71 as shown in [Figure 13](#). The serial bus is still active when the LM71 is in shutdown. When in shutdown mode the LM71 always will output 1000 0000 0000 1111. This is the manufacturer's/Device ID information. The first 5-bits of the field (1000 0XXX) are reserved for manufacturer's ID.

9.5 INTERNAL REGISTER STRUCTURE

The LM71 has three registers, the temperature register, the configuration register and the manufacturer's/device identification register. The temperature and manufacturer's/device identification registers are read only. The configuration register is write only.

9.5.1 Configuration Register

(Selects shutdown or continuous conversion modes):

Table 2. (Write Only):

D15	D14	D13	D12	D11	D10	D9	D8	D7	D6	D5	D4	D3	D2	D1	D0
X	X	X	X	X	X	X	X	Shutdown							

D0–D15 set to XX FF hex enables shutdown mode.

D0–D15 set to 00 00 hex sets Continuous conversion mode.

Note: setting D0-D15 to any other values may place the LM70 into a manufacturer's test mode, upon which the LM71 will stop responding as described. These test modes are to be used for TI production testing only. See [SERIAL BUS INTERFACE](#) for a complete discussion.

9.5.2 Temperature Register

Table 3. (Read Only):

D15	D14	D13	D12	D11	D10	D9	D8	D7	D6	D5	D4	D3	D2	D1	D0
MSB	Bit 12	Bit 11	Bit 10	Bit 9	Bit 8	Bit 7	Bit 6	Bit 5	Bit 4	Bit 3	Bit 2	Bit1	LSB	1	1

D0–D1: Logic 1 will be output on SI/O.

D2–D15: Temperature Data. One LSB = 0.03125°C. Two's complement format.

9.5.3 Manufacturer/Device ID Register

Table 4. (Read Only):

D15	D14	D13	D12	D11	D10	D9	D8	D7	D6	D5	D4	D3	D2	D1	D0
1	0	0	0	0	0	0	0	0	0	0	0	1	1	1	1

D0–D1: Logic 1 will be output on SI/O.

D2–D15: Manufacturer's/Device ID Data. This register is accessed whenever the LM71 is in shutdown mode.

9.6 Serial Bus Timing Diagrams

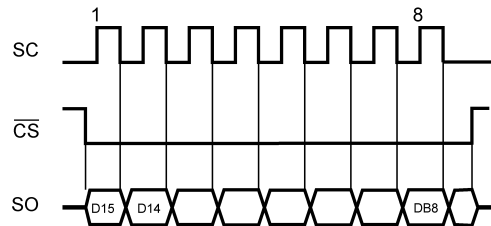

Figure 11. Reading Continuous Conversion - Single Eight-Bit Frame

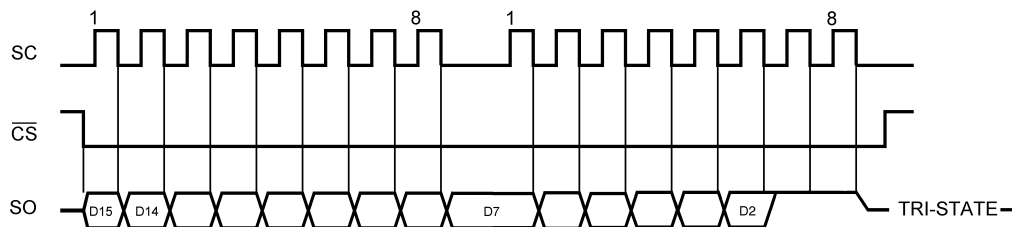

Figure 12. Reading Continuous Conversion - Two Eight-Bit Frames

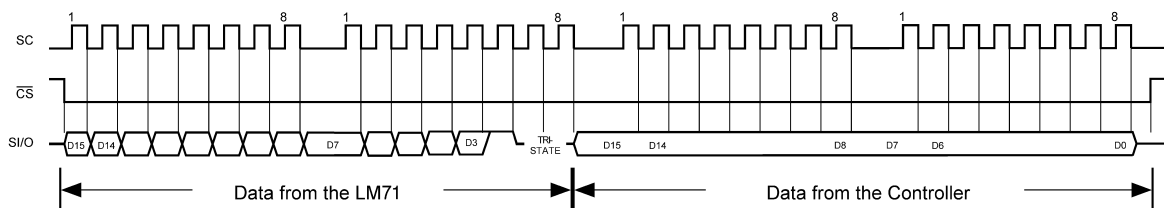

Figure 13. Writing Shutdown Control

9.7 Application Hints

To get the expected results when measuring temperature with an integrated circuit temperature sensor like the LM71, it is important to understand that the sensor measures its own die temperature. For the LM71, the best thermal path between the die and the outside world is through the LM71's pins. In the SOT-23 package, all the pins on the LM71 will have an equal effect on the die temperature. Because the pins represent a good thermal path to the LM71 die, the LM71 will provide an accurate measurement of the temperature of the printed circuit board on which it is mounted. There is a less efficient thermal path between the plastic package and the LM71 die. If the ambient air temperature is significantly different from the printed circuit board temperature, it will have a small effect on the measured temperature.

In probe-type applications, the LM71 can be mounted inside a sealed-end metal tube, and can then be dipped into a bath or screwed into a threaded hole in a tank. As with any IC, the LM71 and accompanying wiring and circuits must be kept insulated and dry, to avoid leakage and corrosion. This is especially true if the circuit may operate at cold temperatures where condensation can occur. Printed-circuit coatings and varnishes such as Humiseal and epoxy paints or dips are often used to insure that moisture cannot corrode the LM71 or its connections.

9.8 Typical Applications

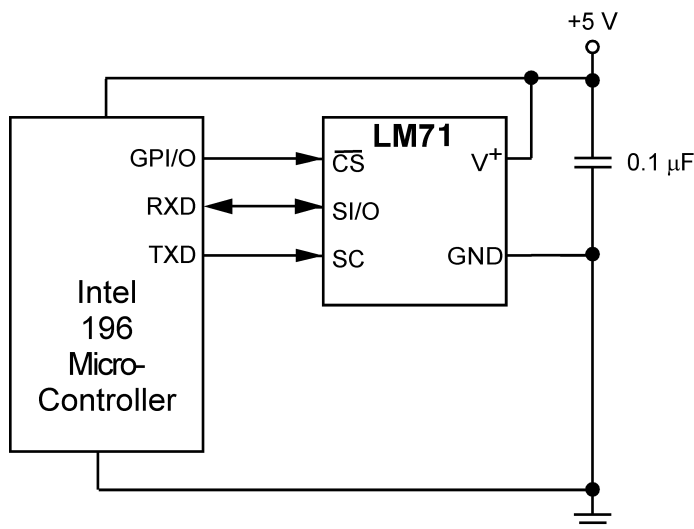

Figure 14. Temperature monitor using Intel 196 processor

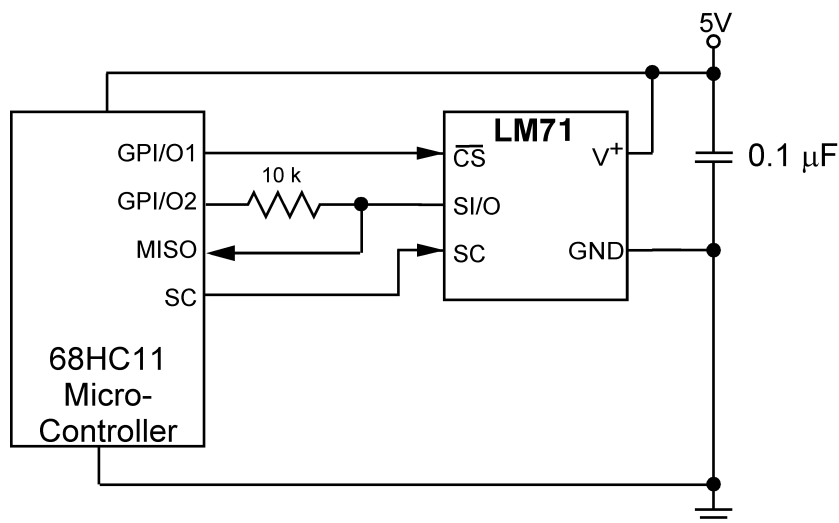

Figure 15. LM71 digital input control using micro-controller's general purpose I/O.

10 Revision History

NOTE: Page numbers for previous revisions may differ from page numbers in the current version.

Changes from Revision D (March 2013) to Revision E	Page
-----------------------------------------------------------	-------------

- Added SNLA296 ulink to the temperature conversion time tablenote..... [4](#)
-

Changes from Revision C (March 2013) to Revision D	Page
-----------------------------------------------------------	-------------

- Changed layout of National Semiconductor Data Sheet to TI format [11](#)
-

PACKAGING INFORMATION

Orderable Device	Status (1)	Package Type	Package Drawing	Pins	Package Qty	Eco Plan (2)	Lead/Ball Finish (6)	MSL Peak Temp (3)	Op Temp (°C)	Device Marking (4/5)	Samples
LM71CIMF	NRND	SOT-23	DBV	5	1000	TBD	Call TI	Call TI		T16C	
LM71CIMF/NOPB	ACTIVE	SOT-23	DBV	5	1000	Green (RoHS & no Sb/Br)	CU SN	Level-1-260C-UNLIM		T16C	Samples
LM71CIMFX/NOPB	ACTIVE	SOT-23	DBV	5	3000	Green (RoHS & no Sb/Br)	CU SN	Level-1-260C-UNLIM	-40 to 150	T16C	Samples
LM71CISD/NOPB	ACTIVE	WSON	NGG	6	1000	Green (RoHS & no Sb/Br)	CU SN	Level-1-260C-UNLIM	-40 to 150	L71CI	Samples
LM71QCIMF/NOPB	ACTIVE	SOT-23	DBV	5	1000	Green (RoHS & no Sb/Br)	CU SN	Level-1-260C-UNLIM	-40 to 150	T16Q	Samples
LM71QCIMFX/NOPB	ACTIVE	SOT-23	DBV	5	3000	Green (RoHS & no Sb/Br)	CU SN	Level-1-260C-UNLIM	-40 to 150	T16Q	Samples

(1) The marketing status values are defined as follows:

ACTIVE: Product device recommended for new designs.

LIFEBUY: TI has announced that the device will be discontinued, and a lifetime-buy period is in effect.

NRND: Not recommended for new designs. Device is in production to support existing customers, but TI does not recommend using this part in a new design.

PREVIEW: Device has been announced but is not in production. Samples may or may not be available.

OBSELETE: TI has discontinued the production of the device.

(2) **RoHS:** TI defines "RoHS" to mean semiconductor products that are compliant with the current EU RoHS requirements for all 10 RoHS substances, including the requirement that RoHS substance do not exceed 0.1% by weight in homogeneous materials. Where designed to be soldered at high temperatures, "RoHS" products are suitable for use in specified lead-free processes. TI may reference these types of products as "Pb-Free".

RoHS Exempt: TI defines "RoHS Exempt" to mean products that contain lead but are compliant with EU RoHS pursuant to a specific EU RoHS exemption.

Green: TI defines "Green" to mean the content of Chlorine (Cl) and Bromine (Br) based flame retardants meet JS709B low halogen requirements of <=1000ppm threshold. Antimony trioxide based flame retardants must also meet the <=1000ppm threshold requirement.

(3) MSL, Peak Temp. - The Moisture Sensitivity Level rating according to the JEDEC industry standard classifications, and peak solder temperature.

(4) There may be additional marking, which relates to the logo, the lot trace code information, or the environmental category on the device.

(5) Multiple Device Markings will be inside parentheses. Only one Device Marking contained in parentheses and separated by a "~" will appear on a device. If a line is indented then it is a continuation of the previous line and the two combined represent the entire Device Marking for that device.

(6) Lead/Ball Finish - Orderable Devices may have multiple material finish options. Finish options are separated by a vertical ruled line. Lead/Ball Finish values may wrap to two lines if the finish value exceeds the maximum column width.

Important Information and Disclaimer: The information provided on this page represents TI's knowledge and belief as of the date that it is provided. TI bases its knowledge and belief on information provided by third parties, and makes no representation or warranty as to the accuracy of such information. Efforts are underway to better integrate information from third parties. TI has taken and continues to take reasonable steps to provide representative and accurate information but may not have conducted destructive testing or chemical analysis on incoming materials and chemicals. TI and TI suppliers consider certain information to be proprietary, and thus CAS numbers and other limited information may not be available for release.

In no event shall TI's liability arising out of such information exceed the total purchase price of the TI part(s) at issue in this document sold by TI to Customer on an annual basis.

OTHER QUALIFIED VERSIONS OF LM71, LM71-Q1 :

- Catalog: [LM71](#)
- Automotive: [LM71-Q1](#)

NOTE: Qualified Version Definitions:

- Catalog - TI's standard catalog product
- Automotive - Q100 devices qualified for high-reliability automotive applications targeting zero defects

TAPE AND REEL INFORMATION

QUADRANT ASSIGNMENTS FOR PIN 1 ORIENTATION IN TAPE

*All dimensions are nominal

Device	Package Type	Package Drawing	Pins	SPQ	Reel Diameter (mm)	Reel Width W1 (mm)	A0 (mm)	B0 (mm)	K0 (mm)	P1 (mm)	W (mm)	Pin1 Quadrant
LM71CIMF	SOT-23	DBV	5	1000	178.0	8.4	3.2	3.2	1.4	4.0	8.0	Q3
LM71CIMF/NOPB	SOT-23	DBV	5	1000	178.0	8.4	3.2	3.2	1.4	4.0	8.0	Q3
LM71CIMFX/NOPB	SOT-23	DBV	5	3000	178.0	8.4	3.2	3.2	1.4	4.0	8.0	Q3
LM71CISD/NOPB	WSON	NGG	6	1000	178.0	12.4	3.3	3.3	1.0	8.0	12.0	Q1
LM71QCIMF/NOPB	SOT-23	DBV	5	1000	178.0	8.4	3.2	3.2	1.4	4.0	8.0	Q3
LM71QCIMFX/NOPB	SOT-23	DBV	5	3000	178.0	8.4	3.2	3.2	1.4	4.0	8.0	Q3

TAPE AND REEL BOX DIMENSIONS

*All dimensions are nominal

Device	Package Type	Package Drawing	Pins	SPQ	Length (mm)	Width (mm)	Height (mm)
LM71CIMF	SOT-23	DBV	5	1000	210.0	185.0	35.0
LM71CIMF/NOPB	SOT-23	DBV	5	1000	210.0	185.0	35.0
LM71CIMFX/NOPB	SOT-23	DBV	5	3000	210.0	185.0	35.0
LM71CISD/NOPB	WSON	NGG	6	1000	210.0	185.0	35.0
LM71QCIMF/NOPB	SOT-23	DBV	5	1000	210.0	185.0	35.0
LM71QCIMFX/NOPB	SOT-23	DBV	5	3000	210.0	185.0	35.0

DBV0005A



PACKAGE OUTLINE

SOT-23 - 1.45 mm max height

SMALL OUTLINE TRANSISTOR

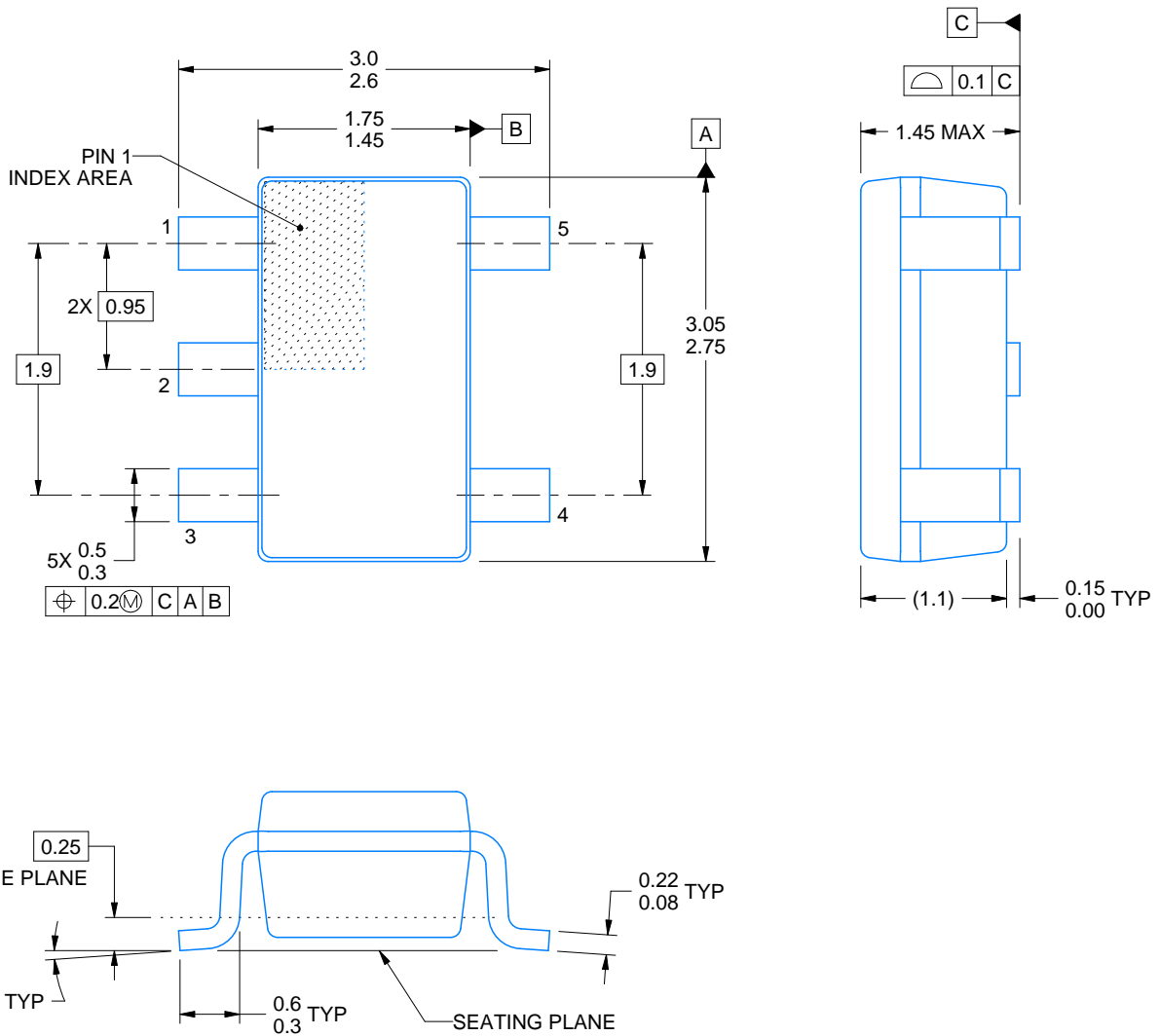

4214839/D 11/2018

NOTES:

1. All linear dimensions are in millimeters. Any dimensions in parenthesis are for reference only. Dimensioning and tolerancing per ASME Y14.5M.
2. This drawing is subject to change without notice.
3. Reference JEDEC MO-178.
4. Body dimensions do not include mold flash, protrusions, or gate burrs. Mold flash, protrusions, or gate burrs shall not exceed 0.15 mm per side.

EXAMPLE BOARD LAYOUT

DBV0005A

SOT-23 - 1.45 mm max height

SMALL OUTLINE TRANSISTOR



LAND PATTERN EXAMPLE
EXPOSED METAL SHOWN
SCALE:15X



SOLDER MASK DETAILS

4214839/D 11/2018

NOTES: (continued)

- 5. Publication IPC-7351 may have alternate designs.
- 6. Solder mask tolerances between and around signal pads can vary based on board fabrication site.

EXAMPLE STENCIL DESIGN

DBV0005A

SOT-23 - 1.45 mm max height

SMALL OUTLINE TRANSISTOR



SOLDER PASTE EXAMPLE
BASED ON 0.125 mm THICK STENCIL
SCALE:15X

4214839/D 11/2018

NOTES: (continued)

7. Laser cutting apertures with trapezoidal walls and rounded corners may offer better paste release. IPC-7525 may have alternate design recommendations.
8. Board assembly site may have different recommendations for stencil design.

NGG0006A

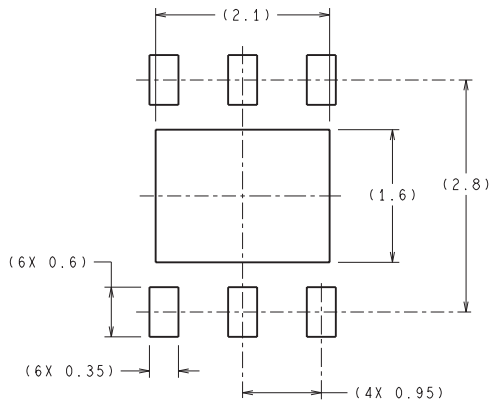

RECOMMENDED LAND PATTERN

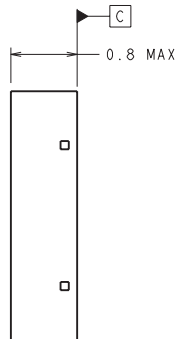
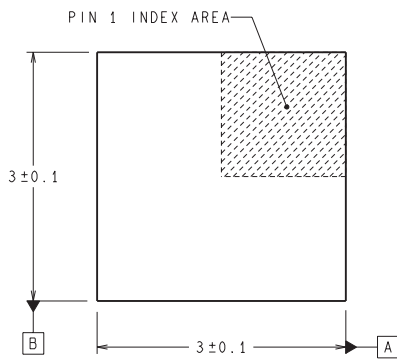

DIMENSIONS ARE IN MILLIMETERS
DIMENSION IN () FOR REFERENCE ONLY

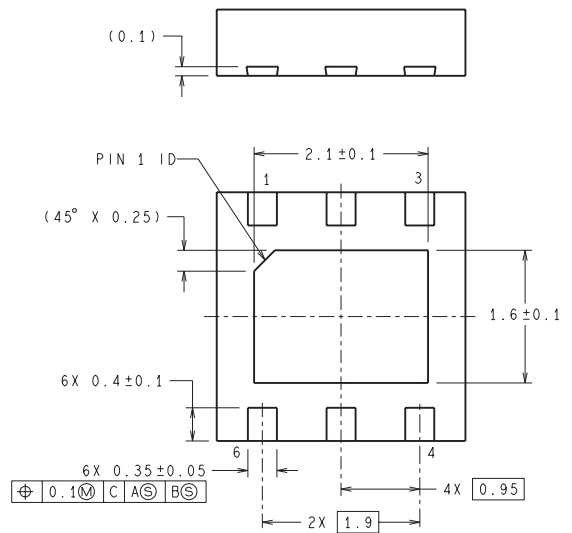

SDE06A (Rev A)

IMPORTANT NOTICE AND DISCLAIMER

TI PROVIDES TECHNICAL AND RELIABILITY DATA (INCLUDING DATASHEETS), DESIGN RESOURCES (INCLUDING REFERENCE DESIGNS), APPLICATION OR OTHER DESIGN ADVICE, WEB TOOLS, SAFETY INFORMATION, AND OTHER RESOURCES "AS IS" AND WITH ALL FAULTS, AND DISCLAIMS ALL WARRANTIES, EXPRESS AND IMPLIED, INCLUDING WITHOUT LIMITATION ANY IMPLIED WARRANTIES OF MERCHANTABILITY, FITNESS FOR A PARTICULAR PURPOSE OR NON-INFRINGEMENT OF THIRD PARTY INTELLECTUAL PROPERTY RIGHTS.

These resources are intended for skilled developers designing with TI products. You are solely responsible for (1) selecting the appropriate TI products for your application, (2) designing, validating and testing your application, and (3) ensuring your application meets applicable standards, and any other safety, security, or other requirements. These resources are subject to change without notice. TI grants you permission to use these resources only for development of an application that uses the TI products described in the resource. Other reproduction and display of these resources is prohibited. No license is granted to any other TI intellectual property right or to any third party intellectual property right. TI disclaims responsibility for, and you will fully indemnify TI and its representatives against, any claims, damages, costs, losses, and liabilities arising out of your use of these resources.

TI's products are provided subject to TI's Terms of Sale (www.ti.com/legal/termsofsale.html) or other applicable terms available either on ti.com or provided in conjunction with such TI products. TI's provision of these resources does not expand or otherwise alter TI's applicable warranties or warranty disclaimers for TI products.

Mailing Address: Texas Instruments, Post Office Box 655303, Dallas, Texas 75265
Copyright © 2019, Texas Instruments Incorporated

Looking for pricing, stock, or lifecycle information?

Click below to explore more details on WIN SOURCE:

 [View LM71CIMFX/NOPB on WIN SOURCE](#)

 [Texas Instruments](#) Information

Optimize Your Supply Chain with WIN SOURCE Solutions

-  Global Sourcing Solution
-  Obsolete Management
-  Cost Control Management
-  Shortage Management
-  Alternative Solution
-  Excess Inventory Management