



THE DATASHEET OF LM556CMX



LM556

LM556 Dual Timer



Literature Number: SNAS549

LM556

Dual Timer

General Description

The LM556 Dual timing circuit is a highly stable controller capable of producing accurate time delays or oscillation. The 556 is a dual 555. Timing is provided by an external resistor and capacitor for each timing function. The two timers operate independently of each other sharing only V_{CC} and ground. The circuits may be triggered and reset on falling waveforms. The output structures may sink or source 200mA.

Features

- Direct replacement for SE556/NE556
- Timing from microseconds through hours
- Operates in both astable and monostable modes
- Replaces two 555 timers
- Adjustable duty cycle
- Output can source or sink 200mA
- Output and supply TTL compatible
- Temperature stability better than 0.005% per °C
- Normally on and normally off output

Applications

- Precision timing
- Pulse generation
- Sequential timing
- Time delay generation
- Pulse width modulation
- Pulse position modulation
- Linear ramp generator

Connection Diagram

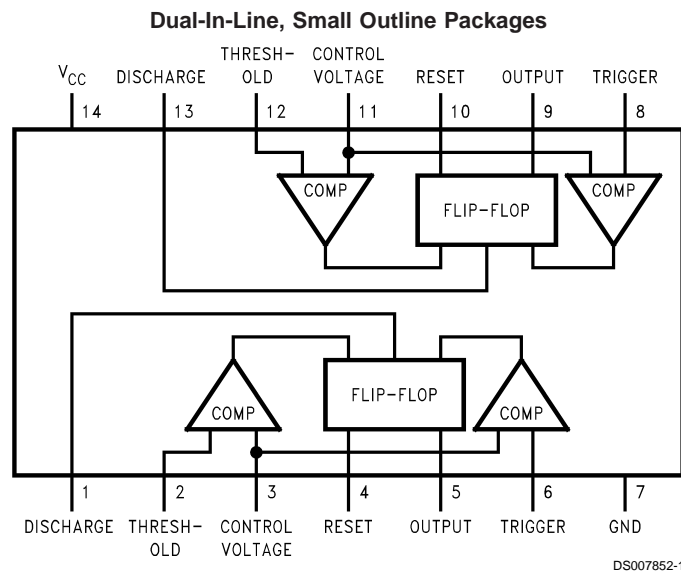

Top View

Ordering Information

Package	Part Number	Package Marking	Media Transport	NSC Drawing
14-Pin SOIC	LM556CM	LM556CM	Rails	M14A
	LM556CMX	LM556CM	2.5k Units Tape and Reel	
14-Pin MDIP	LM556CN	LM556CN	Rails	N14a

Schematic Diagram

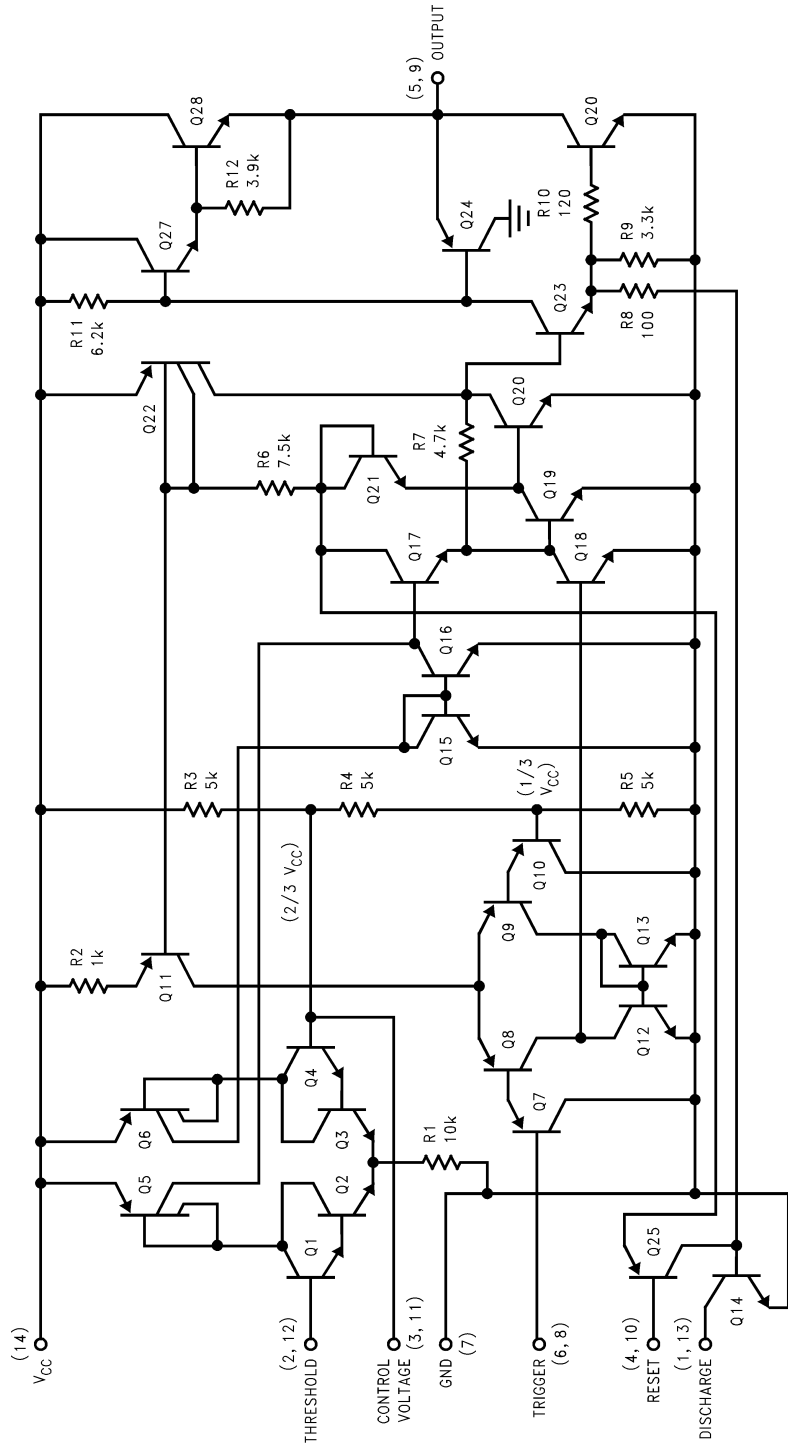

DS007852-2

Absolute Maximum Ratings (Note 1)

If Military/Aerospace specified devices are required, please contact the National Semiconductor Sales Office/Distributors for availability and specifications.

Supply Voltage	+18V
Power Dissipation (Note 2)	
LM556CM	410 mW
LM556CN	1620 mW
Operating Temperature Ranges	
LM556C	0°C to +70°C

Storage Temperature Range –65°C to +150°C

Soldering Information

Dual-In-Line Package	
Soldering (10 Seconds)	260°C
Small Outline Packages	
Vapor Phase (60 Seconds)	215°C
Infrared (15 Seconds)	220°C

See AN-450 "Surface Mounting Methods and Their Effect on Product Reliability" for other methods of soldering surface mount devices.

Electrical Characteristics

($T_A = 25^\circ\text{C}$, $V_{CC} = +5\text{V}$ to +15V, unless otherwise specified)

Parameter	Conditions	Limits			Units
		LM556C			
		Min	Typ	Max	
Supply Voltage		4.5		16	V
Supply Current (Each Timer Section)	$V_{CC} = 5\text{V}$, $R_L = \infty$ $V_{CC} = 15\text{V}$, $R_L = \infty$ (Low State) (Note 3)		3 10	6 14	mA
Timing Error, Monostable					
Initial Accuracy			0.75		%
Drift with Temperature	$R_A = 1\text{k}$ to 100k Ω , $C = 0.1\mu\text{F}$, (Note 4)		50		ppm/°C
Accuracy over Temperature			1.5		%
Drift with Supply			0.1		%/V
Timing Error, Astable					
Initial Accuracy			2.25		%
Drift with Temperature	R_A , $R_B = 1\text{k}$ to 100k Ω , $C = 0.1\mu\text{F}$, (Note 4)		150		ppm/°C
Accuracy over Temperature			3.0		%
Drift with Supply			0.30		%/V
Trigger Voltage	$V_{CC} = 15\text{V}$ $V_{CC} = 5\text{V}$	4.5 1.25	5 1.67	5.5 2.0	V V
Trigger Current			0.2	1.0	μA
Reset Voltage		0.4	0.5	1	V
Reset Current			0.1	0.6	mA
Threshold Current	$V_{TH} = V$ -Control (Note 6) $V_{TH} = 11.2\text{V}$		0.03	0.1 250	μA nA
Control Voltage Level and Threshold Voltage	$V_{CC} = 15\text{V}$ $V_{CC} = 5\text{V}$	9 2.6	10 3.33	11 4	V
Pin 1, 13 Leakage Output High			1	100	nA
Pin 1, 13 Sat	(Note 7)				
Output Low	$V_{CC} = 15\text{V}$, $I = 15\text{mA}$		180	300	mV
Output Low	$V_{CC} = 4.5\text{V}$, $I = 4.5\text{mA}$		80	200	mV
Output Voltage Drop (Low)	$V_{CC} = 15\text{V}$ $I_{SINK} = 10\text{mA}$ $I_{SINK} = 50\text{mA}$ $I_{SINK} = 100\text{mA}$ $I_{SINK} = 200\text{mA}$ $V_{CC} = 5\text{V}$ $I_{SINK} = 8\text{mA}$ $I_{SINK} = 5\text{mA}$		0.1 0.4 2 2.5	0.25 0.75 2.75	V V V V
			0.25	0.35	V

Electrical Characteristics (Continued)

($T_A = 25^\circ\text{C}$, $V_{CC} = +5\text{V}$ to $+15\text{V}$, unless otherwise specified)

Parameter	Conditions	Limits			Units
		LM556C			
		Min	Typ	Max	
Output Voltage Drop (High)	$I_{\text{SOURCE}} = 200\text{mA}$, $V_{CC} = 15\text{V}$		12.5		V
	$I_{\text{SOURCE}} = 100\text{mA}$, $V_{CC} = 15\text{V}$	12.75	13.3		V
	$V_{CC} = 5\text{V}$	2.75	3.3		V
Rise Time of Output			100		ns
Fall Time of Output			100		ns
Matching Characteristics	(Note 8)				
Initial Timing Accuracy			0.1	2.0	%
Timing Drift with Temperature			± 10		ppm/ $^\circ\text{C}$
Drift with Supply Voltage			0.2	0.5	%/V

Note 1: Absolute Maximum Ratings indicate limits beyond which damage to the device may occur.

Note 2: For operating at elevated temperatures the device must be derated based on a $+150^\circ\text{C}$ maximum junction temperature and a thermal resistance of 77°C/W (Plastic Dip), and 110°C/W (SO-14 Narrow).

Note 3: Supply current when output high typically 1mA less at $V_{CC} = 5\text{V}$.

Note 4: Tested at $V_{CC} = 5\text{V}$ and $V_{CC} = 15\text{V}$.

Note 5: As reset voltage lowers, timing is inhibited and then the output goes low.

Note 6: This will determine the maximum value of $R_A + R_B$ for 15V operation. The maximum total ($R_A + R_B$) is 20 M Ω .

Note 7: No protection against excessive pin 1, 13 current is necessary providing the package dissipation rating will not be exceeded.

Note 8: Matching characteristics refer to the difference between performance characteristics of each timer section.

Note 9: Refer to RETS556X drawing of military LM556J versions.

Typical Performance Characteristics

Minimum Pulse Width Required for Triggering

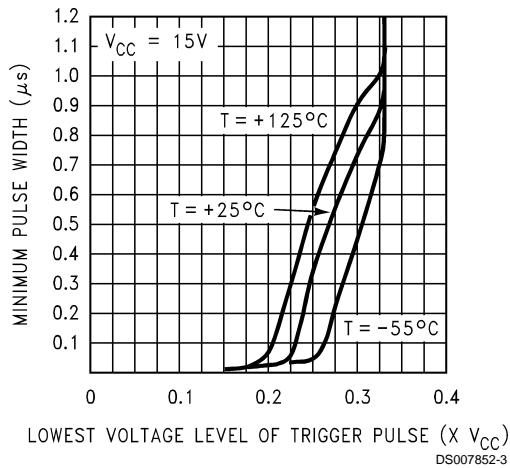

Supply Current vs. Supply Voltage (Each Section)

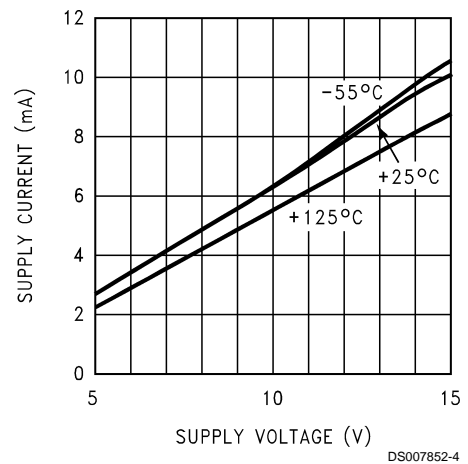

Typical Performance Characteristics (Continued)

High Output Voltage vs. Output Source Current

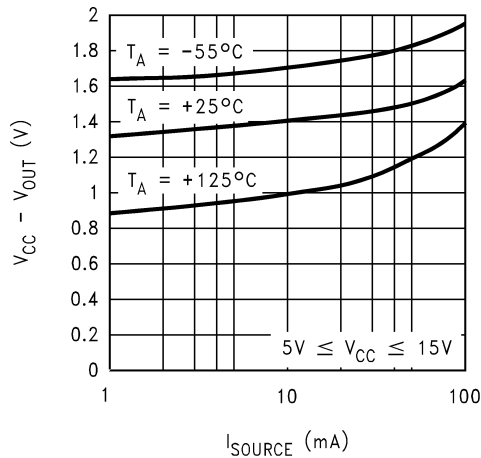

Low Output Voltage vs. Output Sink Current

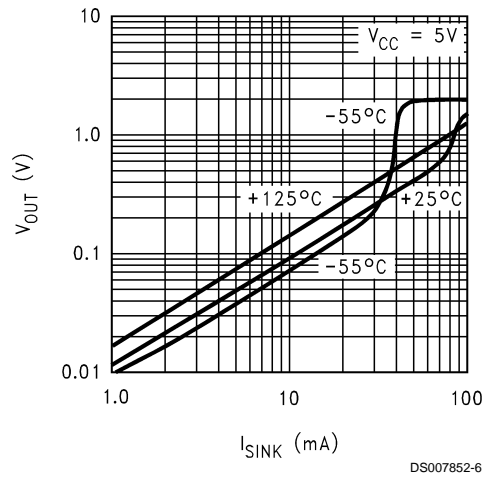

Low Output Voltage vs. Output Sink Current

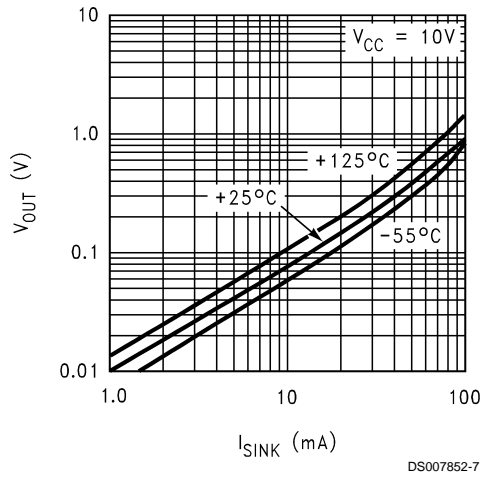

Low Output Voltage vs. Output Sink Current

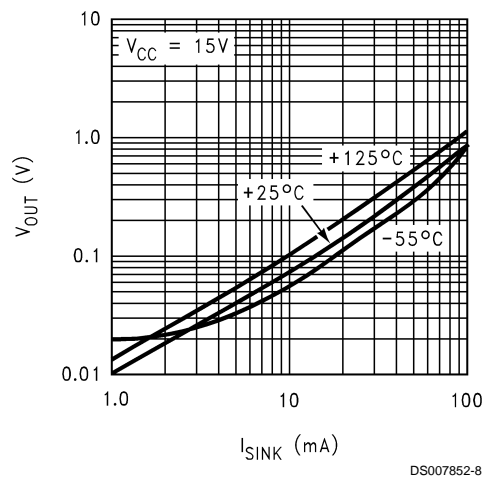

Output Propagation Delay vs. Voltage Level of Trigger Pulse

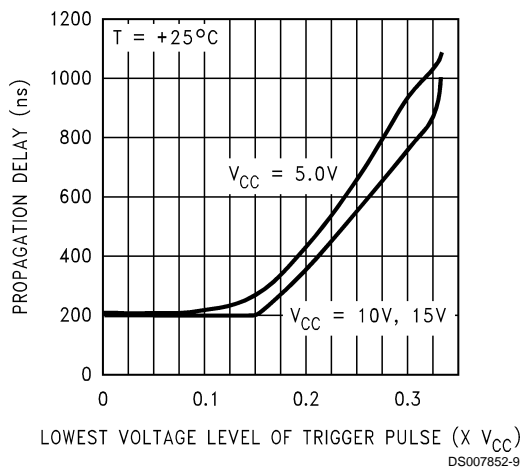

Output Propagation Delay vs. Voltage Level of Trigger Pulse

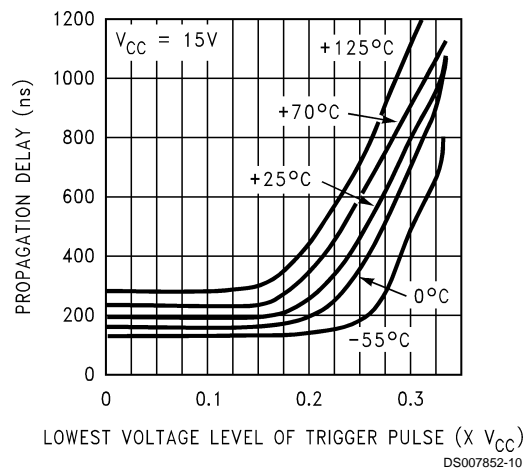

Typical Performance Characteristics (Continued)

Discharge Transistor (Pin 1, 13) Voltage vs. Sink Current

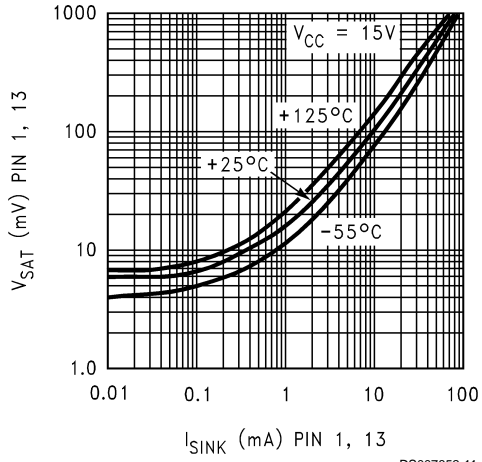

Discharge Transistor (Pin 1, 13) Voltage vs. Sink Current

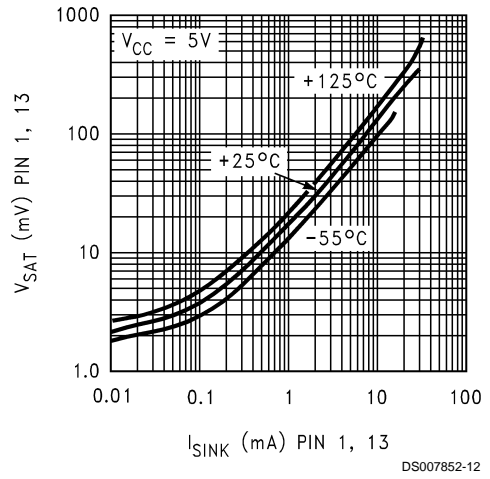

Physical Dimensions inches (millimeters) unless otherwise noted

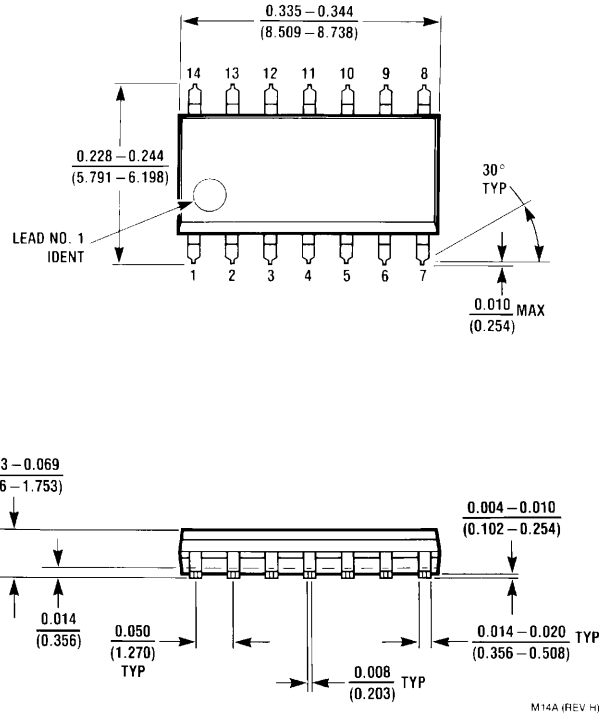

**Small Outline Package (M)
NS Package Number M14A**

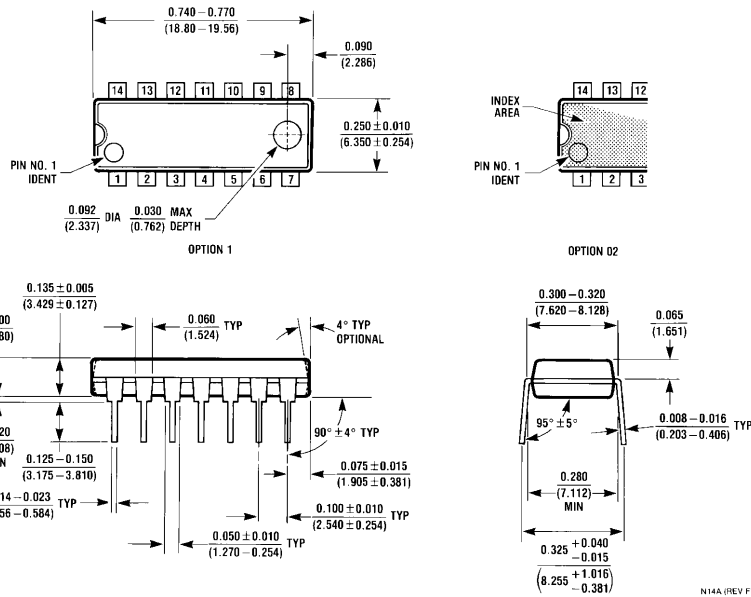

**14-Lead (0.118" Wide) Molded Mini Small Outline Package
NS Package Number N14A**

Notes

LIFE SUPPORT POLICY

NATIONAL'S PRODUCTS ARE NOT AUTHORIZED FOR USE AS CRITICAL COMPONENTS IN LIFE SUPPORT DEVICES OR SYSTEMS WITHOUT THE EXPRESS WRITTEN APPROVAL OF THE PRESIDENT AND GENERAL COUNSEL OF NATIONAL SEMICONDUCTOR CORPORATION. As used herein:

1. Life support devices or systems are devices or systems which, (a) are intended for surgical implant into the body, or (b) support or sustain life, and whose failure to perform when properly used in accordance with instructions for use provided in the labeling, can be reasonably expected to result in a significant injury to the user.
2. A critical component is any component of a life support device or system whose failure to perform can be reasonably expected to cause the failure of the life support device or system, or to affect its safety or effectiveness.



National Semiconductor Corporation
Americas
Tel: 1-800-272-9959
Fax: 1-800-737-7018
Email: support@nsc.com
www.national.com

National Semiconductor Europe
Fax: +49 (0) 180-530 85 86
Email: europe.support@nsc.com
Deutsch Tel: +49 (0) 69 9508 6208
English Tel: +44 (0) 870 24 0 2171
Français Tel: +33 (0) 1 41 91 8790

National Semiconductor Asia Pacific Customer Response Group
Tel: 65-2544466
Fax: 65-2504466
Email: ap.support@nsc.com

National Semiconductor Japan Ltd.
Tel: 81-3-5639-7560
Fax: 81-3-5639-7507

IMPORTANT NOTICE

Texas Instruments Incorporated and its subsidiaries (TI) reserve the right to make corrections, modifications, enhancements, improvements, and other changes to its products and services at any time and to discontinue any product or service without notice. Customers should obtain the latest relevant information before placing orders and should verify that such information is current and complete. All products are sold subject to TI's terms and conditions of sale supplied at the time of order acknowledgment.

TI warrants performance of its hardware products to the specifications applicable at the time of sale in accordance with TI's standard warranty. Testing and other quality control techniques are used to the extent TI deems necessary to support this warranty. Except where mandated by government requirements, testing of all parameters of each product is not necessarily performed.

TI assumes no liability for applications assistance or customer product design. Customers are responsible for their products and applications using TI components. To minimize the risks associated with customer products and applications, customers should provide adequate design and operating safeguards.

TI does not warrant or represent that any license, either express or implied, is granted under any TI patent right, copyright, mask work right, or other TI intellectual property right relating to any combination, machine, or process in which TI products or services are used. Information published by TI regarding third-party products or services does not constitute a license from TI to use such products or services or a warranty or endorsement thereof. Use of such information may require a license from a third party under the patents or other intellectual property of the third party, or a license from TI under the patents or other intellectual property of TI.

Reproduction of TI information in TI data books or data sheets is permissible only if reproduction is without alteration and is accompanied by all associated warranties, conditions, limitations, and notices. Reproduction of this information with alteration is an unfair and deceptive business practice. TI is not responsible or liable for such altered documentation. Information of third parties may be subject to additional restrictions.

Resale of TI products or services with statements different from or beyond the parameters stated by TI for that product or service voids all express and any implied warranties for the associated TI product or service and is an unfair and deceptive business practice. TI is not responsible or liable for any such statements.

TI products are not authorized for use in safety-critical applications (such as life support) where a failure of the TI product would reasonably be expected to cause severe personal injury or death, unless officers of the parties have executed an agreement specifically governing such use. Buyers represent that they have all necessary expertise in the safety and regulatory ramifications of their applications, and acknowledge and agree that they are solely responsible for all legal, regulatory and safety-related requirements concerning their products and any use of TI products in such safety-critical applications, notwithstanding any applications-related information or support that may be provided by TI. Further, Buyers must fully indemnify TI and its representatives against any damages arising out of the use of TI products in such safety-critical applications.

TI products are neither designed nor intended for use in military/aerospace applications or environments unless the TI products are specifically designated by TI as military-grade or "enhanced plastic." Only products designated by TI as military-grade meet military specifications. Buyers acknowledge and agree that any such use of TI products which TI has not designated as military-grade is solely at the Buyer's risk, and that they are solely responsible for compliance with all legal and regulatory requirements in connection with such use.

TI products are neither designed nor intended for use in automotive applications or environments unless the specific TI products are designated by TI as compliant with ISO/TS 16949 requirements. Buyers acknowledge and agree that, if they use any non-designated products in automotive applications, TI will not be responsible for any failure to meet such requirements.

Following are URLs where you can obtain information on other Texas Instruments products and application solutions:

Products

Audio	www.ti.com/audio
Amplifiers	amplifier.ti.com
Data Converters	dataconverter.ti.com
DLP® Products	www.dlp.com
DSP	dsp.ti.com
Clocks and Timers	www.ti.com/clocks
Interface	interface.ti.com
Logic	logic.ti.com
Power Mgmt	power.ti.com
Microcontrollers	microcontroller.ti.com
RFID	www.ti-rfid.com
OMAP Mobile Processors	www.ti.com/omap
Wireless Connectivity	www.ti.com/wirelessconnectivity

Applications

Communications and Telecom	www.ti.com/communications
Computers and Peripherals	www.ti.com/computers
Consumer Electronics	www.ti.com/consumer-apps
Energy and Lighting	www.ti.com/energy
Industrial	www.ti.com/industrial
Medical	www.ti.com/medical
Security	www.ti.com/security
Space, Avionics and Defense	www.ti.com/space-avionics-defense
Transportation and Automotive	www.ti.com/automotive
Video and Imaging	www.ti.com/video

TI E2E Community Home Page

e2e.ti.com

Mailing Address: Texas Instruments, Post Office Box 655303, Dallas, Texas 75265
Copyright © 2011, Texas Instruments Incorporated







Looking for pricing, stock, or lifecycle information?

Click below to explore more details on WIN SOURCE:

 [View LM556CMX](#) on WIN SOURCE

 [Texas Instruments](#) Information

Optimize Your Supply Chain with WIN SOURCE Solutions

-  Global Sourcing Solution
-  Obsolete Management
-  Cost Control Management
-  Shortage Management
-  Alternative Solution
-  Excess Inventory Management