



**THE DATASHEET OF
LM5110-3MX/NOPB**



LM5110 Dual 5-A Compound Gate Driver With Negative Output Voltage Capability

1 Features

- Independently Drives Two N-Channel MOSFETs
- Compound CMOS and Bipolar Outputs Reduce Output Current Variation
- 5A sink/3A Source Current Capability
- Two Channels can be Connected in Parallel to Double the Drive Current
- Independent Inputs (TTL Compatible)
- Fast Propagation Times (25-ns Typical)
- Fast Rise and Fall Times (14-ns/12-ns Rise/Fall With 2-nF Load)
- Dedicated Input Ground Pin (IN_REF) for Split Supply or Single Supply Operation
- Outputs Swing from V_{CC} to V_{EE} Which Can Be Negative Relative to Input Ground
- Available in Dual Noninverting, Dual Inverting and Combination Configurations
- Shutdown Input Provides Low Power Mode
- Supply Rail Undervoltage Lockout Protection
- Pin-Out Compatible With Industry Standard Gate Drivers
- Packages:
 - SOIC-8
 - WSON-10 (4 mm × 4 mm)

2 Applications

- Synchronous Rectifier Gate Drivers
- Switch-Mode Power Supply Gate Driver
- Solenoid and Motor Drivers

3 Description

The LM5110 Dual Gate Driver replaces industry standard gate drivers with improved peak output current and efficiency. Each “compound” output driver stage includes MOS and bipolar transistors operating in parallel that together sink more than 5A peak from capacitive loads. Combining the unique characteristics of MOS and bipolar devices reduces drive current variation with voltage and temperature. Separate input and output ground pins provide Negative Drive Capability allowing the user to drive MOSFET gates with positive and negative VGS voltages. The gate driver control inputs are referenced to a dedicated input ground (IN_REF). The gate driver outputs swing from V_{CC} to the output ground V_{EE} which can be negative with respect to IN_REF. Undervoltage lockout protection and a shutdown input pin are also provided. The drivers can be operated in parallel with inputs and outputs connected to double the drive current capability. This device is available in the SOIC-8 and the thermally-enhanced WSON-10 packages.

Device Information⁽¹⁾

| PART NUMBER | PACKAGE | BODY SIZE (NOM) |
|-------------|-----------|-------------------|
| LM5110 | SOIC (8) | 4.90 mm × 3.91 mm |
| | WSON (10) | 4.00 mm × 4.00 mm |

(1) For all available packages, see the orderable addendum at the end of the data sheet.

Simplified Application Diagram

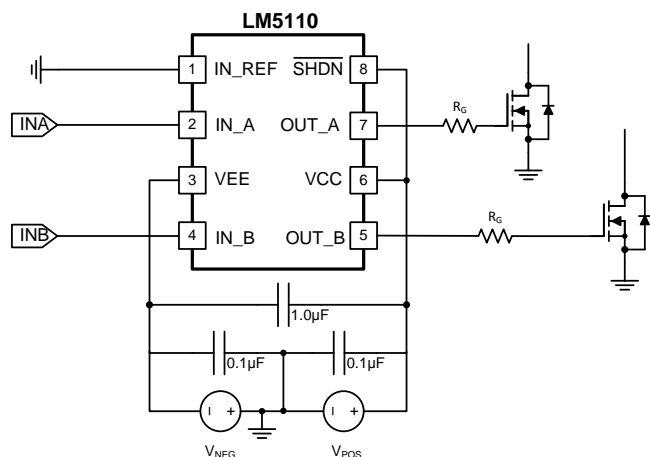

Copyright © 2016, Texas Instruments Incorporated



Table of Contents

| | | | |
|--|----------|--|-----------|
| 1 Features | 1 | 8.3 Feature Description | 10 |
| 2 Applications | 1 | 8.4 Device Functional Modes..... | 11 |
| 3 Description | 1 | 9 Applications and Implementation | 12 |
| 4 Revision History | 2 | 9.1 Application Information..... | 12 |
| 5 Device Options | 3 | 9.2 Typical Application | 13 |
| 6 Pin Configuration and Functions | 3 | 10 Power Supply Recommendations | 15 |
| 7 Specifications | 4 | 11 Layout | 15 |
| 7.1 Absolute Maximum Ratings | 4 | 11.1 Layout Guidelines | 15 |
| 7.2 ESD Ratings..... | 4 | 11.2 Layout Example | 16 |
| 7.3 Recommended Operating Conditions | 4 | 11.3 Thermal Considerations | 16 |
| 7.4 Thermal Information | 4 | 12 Device and Documentation Support | 19 |
| 7.5 Electrical Characteristics..... | 5 | 12.1 Receiving Notification of Documentation Updates | 19 |
| 7.6 Switching Characteristics | 5 | 12.2 Community Resources..... | 19 |
| 7.7 Typical Characteristics | 7 | 12.3 Trademarks | 19 |
| 8 Detailed Description | 9 | 12.4 Electrostatic Discharge Caution..... | 19 |
| 8.1 Overview | 9 | 12.5 Glossary | 19 |
| 8.2 Functional Block Diagram | 9 | 13 Mechanical, Packaging, and Orderable Information | 19 |

4 Revision History

NOTE: Page numbers for previous revisions may differ from page numbers in the current version.

| Changes from Revision A (November 2012) to Revision B | Page |
|--|-------------|
| • Added <i>ESD Ratings</i> table, <i>Feature Description</i> section, <i>Device Functional Modes</i> , <i>Application and Implementation</i> section, <i>Power Supply Recommendations</i> section, <i>Layout</i> section, <i>Device and Documentation Support</i> section, and <i>Mechanical, Packaging, and Orderable Information</i> section | 1 |
| • Added <i>Thermal Information</i> table. | 4 |

5 Device Options

Table 1. Configuration Table

| PART NUMBER | “A” OUTPUT CONFIGURATION | “B” OUTPUT CONFIGURATION | PACKAGE |
|-------------|--------------------------|--------------------------|---------|
| LM5110-1M | Noninverting | Noninverting | SOIC- 8 |
| LM5110-2M | Inverting | Inverting | SOIC- 8 |
| LM5110-3M | Inverting | Noninverting | SOIC- 8 |
| LM5110-1SD | Noninverting | Noninverting | WSO-10 |
| LM5110-2SD | Inverting | Inverting | WSO-10 |
| LM5110-3SD | Inverting | Noninverting | WSO-10 |

6 Pin Configuration and Functions

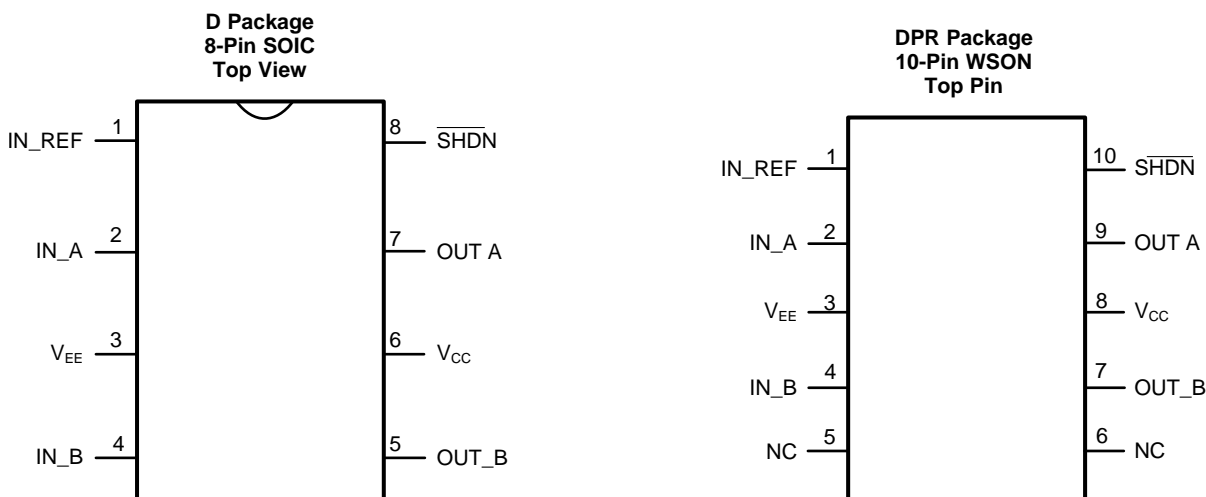

Pin Functions

| PIN | | | I/O ⁽¹⁾ | DESCRIPTION | APPLICATION INFORMATION |
|------|--------------------|-----------------|--------------------|-------------------------------------|--|
| SOIC | WSO ⁽²⁾ | NAME | | | |
| 1 | 1 | IN_REF | G | Ground reference for control inputs | Connect to V _{EE} for standard positive only output voltage swing. Connect to system logic ground reference for positive and negative output voltage swing. |
| 2 | 2 | IN_A | I | 'A' side control input | TTL compatible thresholds. |
| 3 | 3 | V _{EE} | G | Power ground of the driver outputs | Connect to either power ground or a negative gate drive supply. |
| 4 | 4 | IN_B | I | 'B' side control input | TTL compatible thresholds. |
| 5 | 7 | OUT_B | O | Output for the 'B' side driver. | Capable of sourcing 3A and sinking 5A. Voltage swing of this output is from V _{CC} to V _{EE} . |
| 6 | 8 | V _{CC} | P | Positive supply | Locally decouple to V _{EE} and IN_REF. |
| 7 | 9 | OUT_A | O | Output for the 'A' side driver. | Capable of sourcing 3A and sinking 5A. Voltage swing of this output is from V _{CC} to V _{EE} . |
| 8 | 10 | nSHDN | I | Shutdown input pin | Pull below 1.5V to activate low power shutdown mode. |

(1) P = Power, G = Ground, I = Input, O = Output, I/O = Input/Output.

(2) Pins 5 and 6 are No Connect for WSO-10 packages.

7 Specifications

7.1 Absolute Maximum Ratings

over operating free-air temperature range (unless otherwise noted)⁽¹⁾⁽²⁾

| | MIN | MAX | UNIT |
|---|------|-----|------|
| V_{CC} to V_{EE} | -0.3 | 15 | V |
| V_{CC} to IN_REF | -0.3 | 15 | V |
| IN to IN_REF, nSHDN to IN_REF | -0.3 | 15 | V |
| IN_REF to V_{EE} | -0.3 | 5 | V |
| Maximum junction temperature, $(T_J(\max))$ | | 150 | °C |
| Operating junction temperature | | 125 | °C |
| Storage temperature, (T_{stg}) | -55 | 150 | °C |

- (1) Stresses beyond those listed under *Absolute Maximum Ratings* may cause permanent damage to the device. These are stress ratings only, which do not imply functional operation of the device at these or any other conditions beyond those indicated under *Recommended Operating Conditions*. Exposure to absolute-maximum-rated conditions for extended periods may affect device reliability.
- (2) If Military/Aerospace specified devices are required, please contact the Texas Instruments Sales Office/ Distributors for availability and specifications.

7.2 ESD Ratings

| | VALUE | UNIT |
|---|-------|------|
| V_{ESD} Electrostatic discharge Human-body model (HBM), per ANSI/ESDA/JEDEC JS-001 ⁽¹⁾ | ±2000 | V |

- (1) JEDEC document JEP155 states that 500-V HBM allows safe manufacturing with a standard ESD control process.

7.3 Recommended Operating Conditions

over operating free-air temperature range (unless otherwise noted)

| | MIN | NOM | MAX | UNIT |
|----------------------|-----|-----|-----|------|
| V_{CC} to V_{EE} | 3.5 | - | 14 | V |
| V_{CC} to IN_REF | 3.5 | - | 14 | V |
| IN_REF to V_{EE} | 0 | | 4 | V |
| Junction Temperature | -40 | | 126 | °C |

7.4 Thermal Information

| THERMAL METRIC ⁽¹⁾ | LM5110 | | UNIT |
|---|----------|------------|------|
| | D (SOIC) | DPR (WSON) | |
| | 8 PINS | 10 PINS | |
| $R_{\theta JA}$ Junction-to-ambient thermal resistance | 114 | 40.1 | °C/W |
| $R_{\theta JC(top)}$ Junction-to-case (top) thermal resistance | 56.6 | 40.4 | °C/W |
| $R_{\theta JB}$ Junction-to-board thermal resistance | 55.2 | 17.3 | °C/W |
| Ψ_{JT} Junction-to-top characterization parameter | 10.3 | 0.5 | °C/W |
| Ψ_{JB} Junction-to-board characterization parameter | 54.6 | 17.5 | °C/W |
| $R_{\theta JC(bot)}$ Junction-to-case (bottom) thermal resistance | - | 6.3 | °C/W |

- (1) For more information about traditional and new thermal metrics, see [Semiconductor and IC Package Thermal Metrics](#) application report.

7.5 Electrical Characteristics

$T_J = -40^{\circ}\text{C}$ to $+125^{\circ}\text{C}$, $V_{CC} = 12\text{V}$, $V_{EE} = \text{IN_REF} = 0\text{V}$, $\text{nSHDN} = V_{CC}$, No Load on OUT_A or OUT_B, unless otherwise specified.

| PARAMETER | TEST CONDITIONS | MIN | TYP | MAX | UNIT | |
|---------------------------|---|---|-----|-----|------|---------------|
| V_{CC} Operating Range | $V_{CC} - \text{IN_REF}$ and $V_{CC} - V_{EE}$ | 3.5 | | 14 | V | |
| V_{CCR} | V_{CC} Under Voltage Lockout (rising) | $V_{CC} - \text{IN_REF}$ | 2.3 | 2.9 | 3.5 | V |
| V_{CCH} | V_{CC} Under Voltage Lockout Hysteresis | | 230 | | mV | |
| I_{CC} | V_{CC} Supply Current (I_{CC}) | $\text{IN_A} = \text{IN_B} = 0\text{V}$ (5110-1) | | 1 | 2 | mA |
| | | $\text{IN_A} = \text{IN_B} = V_{CC}$ (5110-2) | | 1 | 2 | |
| | | $\text{IN_A} = V_{CC}$, $\text{IN_B} = 0\text{V}$ (5110-3) | | 1 | 2 | |
| I_{CCSD} | V_{CC} Shutdown Current (I_{CC}) | $\text{nSHDN} = 0\text{V}$ | | 18 | 25 | μA |
| CONTROL INPUTS | | | | | | |
| V_{IH} | Logic High | | 2.2 | | V | |
| V_{IL} | Logic Low | | | 0.8 | V | |
| HYS | Input Hysteresis | | 400 | | mV | |
| I_{IL} | Input Current Low | $\text{IN_A} = \text{IN_B} = V_{CC}$ (5110-1-2-3) | -1 | 0.1 | 1 | μA |
| I_{IH} | Input Current High | $\text{IN_A} = \text{IN_B} = V_{CC}$ (5110-1) | 10 | 18 | 25 | |
| | | $\text{IN_A} = \text{IN_B} = V_{CC}$ (5110-2) | -1 | 0.1 | 1 | |
| | | $\text{IN_A} = V_{CC}$ (5110-3) | -1 | 0.1 | 1 | |
| | | $\text{IN_B} = V_{CC}$ (5110-3) | 10 | 18 | 25 | |
| SHUTDOWN INPUT | | | | | | |
| ISD | Pullup Current | $\text{nSHDN} = 0\text{V}$ | | -18 | -25 | μA |
| VSDR | Shutdown Threshold | nSHDN rising | 0.8 | 1.5 | 2.2 | V |
| VSDH | Shutdown Hysteresis | | | 165 | | mV |
| OUTPUT DRIVERS | | | | | | |
| R_{OH} | Output Resistance High | $I_{OUT} = -10\text{mA}$ ⁽¹⁾ | | 30 | 50 | Ω |
| R_{OL} | Output Resistance Low | $I_{OUT} = +10\text{mA}$ ⁽¹⁾ | | 1.4 | 2.5 | Ω |
| I_{Source} | Peak Source Current | $\text{OUTA/OUTB} = V_{CC}/2$, 200 ns Pulsed Current | | 3 | | A |
| I_{Sink} | Peak Sink Current | $\text{OUTA/OUTB} = V_{CC}/2$, 200 ns Pulsed Current | | 5 | | A |
| LATCHUP PROTECTION | | | | | | |
| | AEC - Q100, Method 004 | $T_J = 150^{\circ}\text{C}$ | | 500 | | mA |

(1) The output resistance specification applies to the MOS device only. The total output current capability is the sum of the MOS and Bipolar devices.

7.6 Switching Characteristics

over operating free-air temperature range (unless otherwise noted)

| PARAMETER | TEST CONDITIONS | MIN | TYP | MAX | UNIT | |
|-----------|--|--|-----|-----|------|----|
| td1 | Propagation Delay Time Low to High, IN rising (IN to OUT) | $C_{LOAD} = 2\text{nF}$, see Figure 2 | | 25 | 40 | ns |
| td2 | Propagation Delay Time High to Low, IN falling (IN to OUT) | $C_{LOAD} = 2\text{nF}$, see Figure 2 | | 25 | 40 | ns |
| t_r | Rise Time | $C_{LOAD} = 2\text{nF}$, see Figure 2 | | 14 | 25 | ns |
| t_f | Fall Time | $C_{LOAD} = 2\text{nF}$, see Figure 2 | | 12 | 25 | ns |

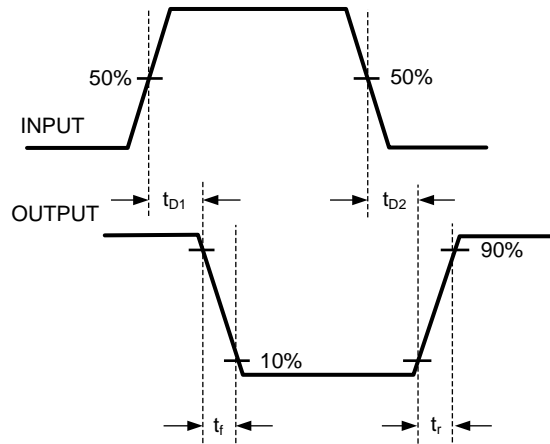

(a)

Figure 1. Inverting

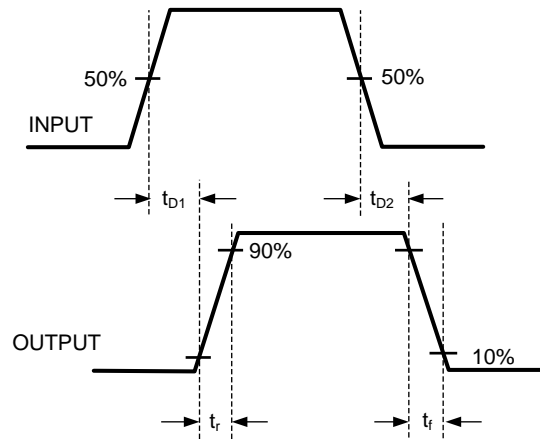

(b)

Figure 2. Noninverting

7.7 Typical Characteristics

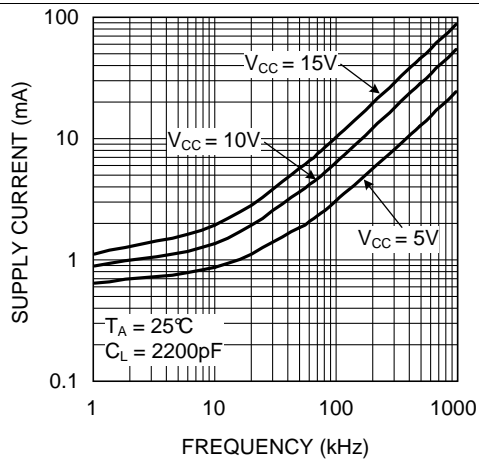

Figure 3. Supply Current vs Frequency

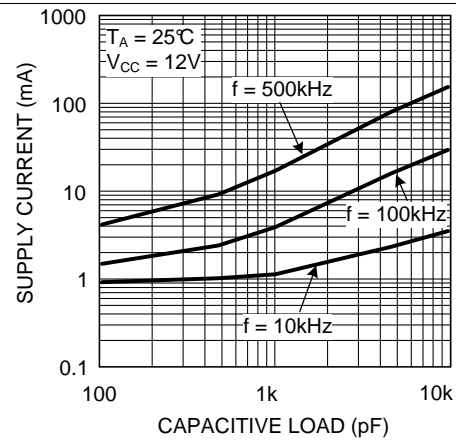

Figure 4. Supply Current vs Load

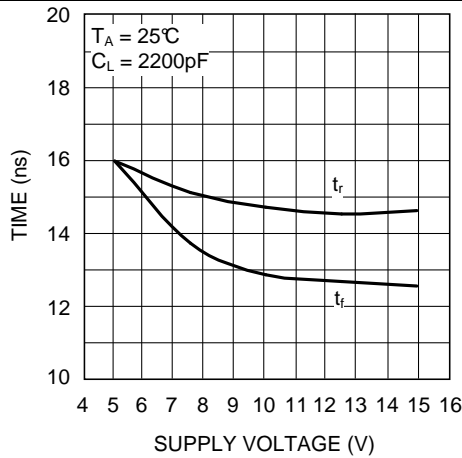

Figure 5. Rise and Fall Time vs Supply Voltage

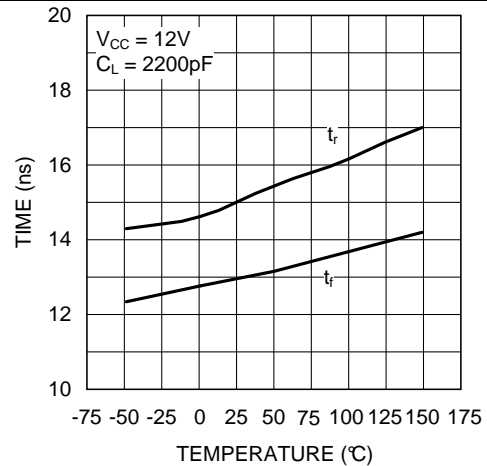

Figure 6. Rise and Fall Time vs Temperature

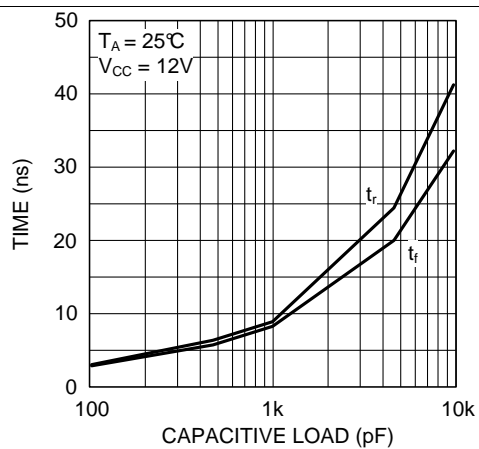

Figure 7. Rise and Fall Time vs Capacitive Load

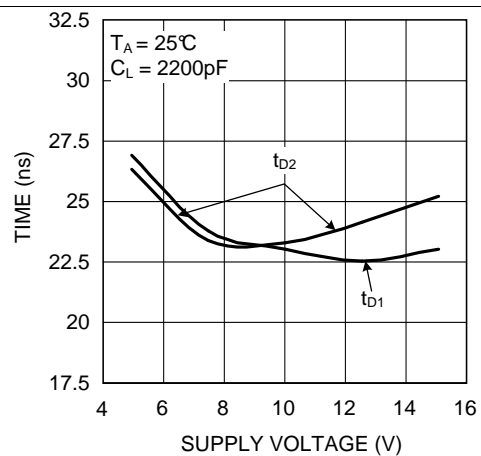

Figure 8. Delay Time vs Supply Voltage

Typical Characteristics (continued)

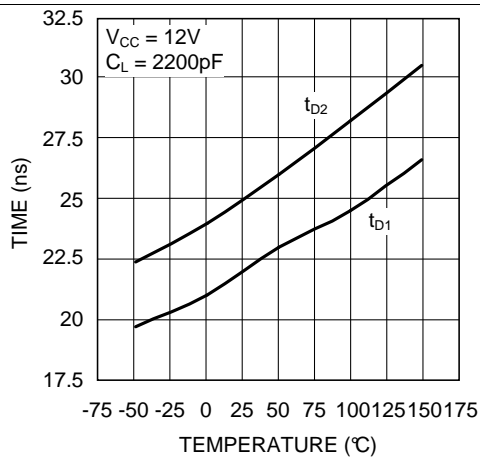

Figure 9. Delay Time vs Temperature

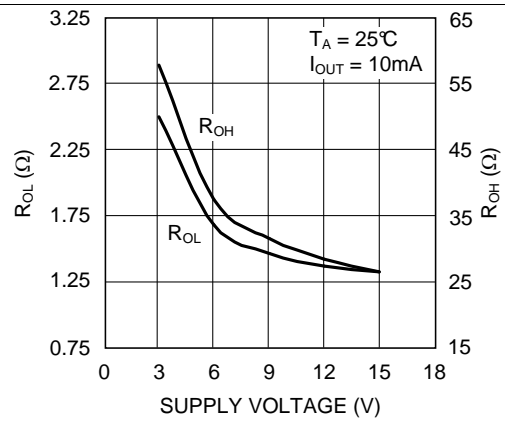

Figure 10. R_{DS(on)} vs Supply Voltage

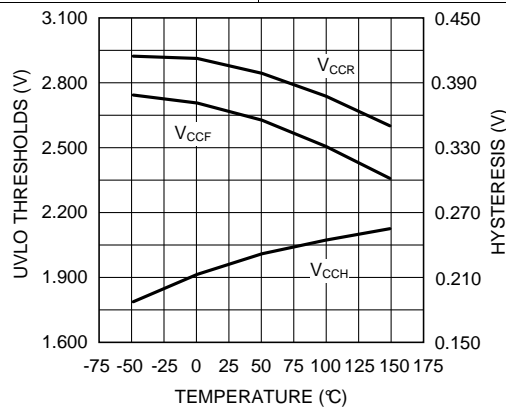

Figure 11. UVLO Thresholds and Hysteresis vs Temperature

8 Detailed Description

8.1 Overview

LM5110 dual gate driver consists of two independent and identical driver channels with TTL compatible logic inputs and high current totem-pole outputs that source or sink current to drive MOSFET gates. The driver output consist of a compound structure with MOS and bipolar transistor operating in parallel to optimize current capability over a wide output voltage and operating temperature range. The bipolar device provides high peak current at the critical threshold region of the MOSFET VGS while the MOS devices provide rail-to-rail output swing. The totem pole output drives the MOSFET gate between the gate drive supply voltage V_{CC} and the power ground potential at the V_{EE} pin.

The LM5110 is available in dual noninverting (-1), dual inverting (-2) and the combination inverting plus noninverting (-3) configurations. All three configurations are offered in the SOIC-8 and WSON-10 plastic packages.

8.2 Functional Block Diagram

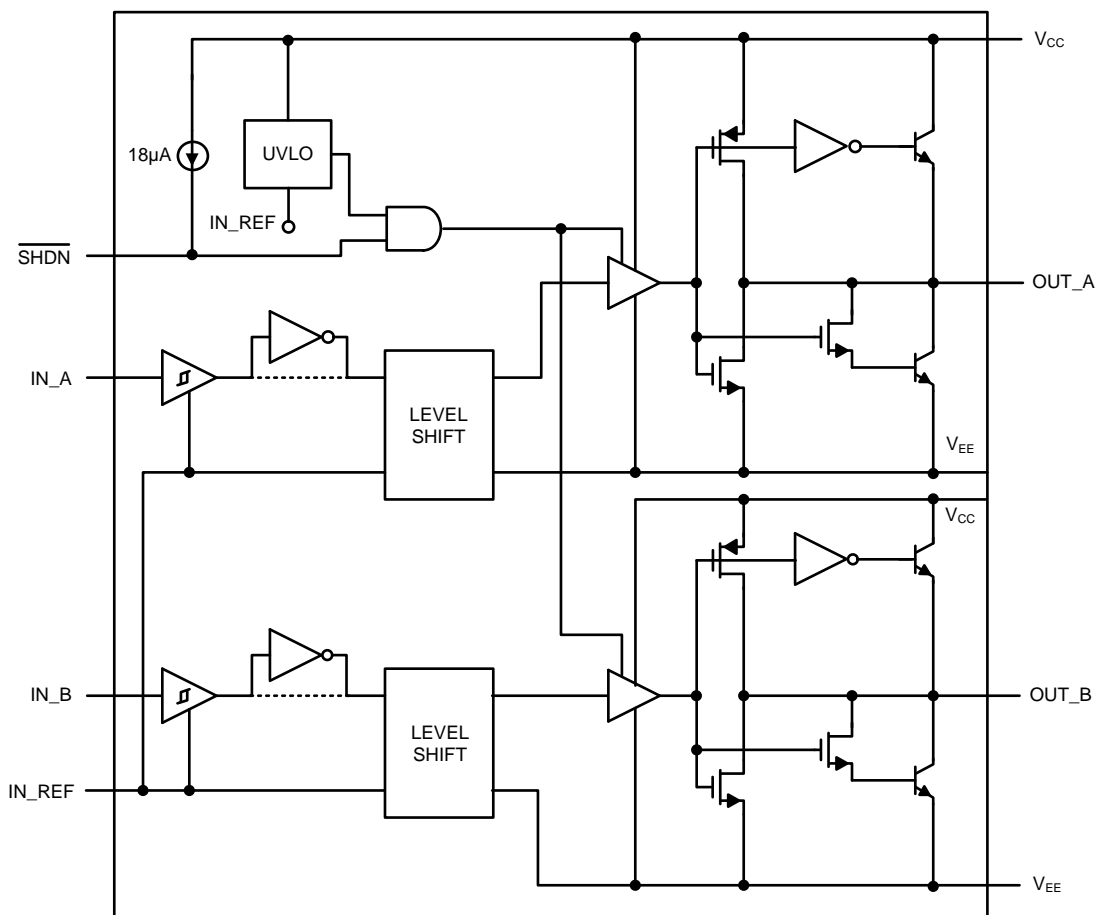

Copyright © 2016, Texas Instruments Incorporated

8.3 Feature Description

8.3.1 Input Stage and Level Shifter

The control inputs of the drivers are high impedance CMOS buffers with TTL compatible threshold voltages. The negative supply of the input buffer is connected to the input ground pin IN_REF. An internal level shifting circuit connects the logic input buffers to the totem pole output drivers. The level shift circuit and separate input/output ground pins provide the option of single supply or split supply configurations. When driving MOSFET gates from a single positive supply, the IN_REF and V_{EE} pins are both connected to the power ground. The LM5110 pinout was designed for compatibility with industry standard gate drivers in single supply gate driver applications. Pin 1 (IN_REF) on the LM5110 is a no-connect on standard driver IC's. Connecting pin 1 to pin 3 (V_{EE}) on the printed-circuit board accommodates the pin-out of both the LM5110 and competitive drivers.

The input stage of each driver should be driven by a signal with a short rise and fall time. Slow rising and falling input signals, although not harmful to the driver, may result in the output switching repeatedly at a high frequency.

The input pins of noninverting drivers have an internal 18- μ A current source pull-down to IN-REF. The input pins of inverting driver channels have neither pullup nor pulldown current sources. Unused input should be tied to IN_REF or VCC and not left open.

8.3.2 Output Stage

The two driver channels of the LM5110 are designed as identical cells. Transistor matching inherent to integrated circuit manufacturing ensures that the AC and DC performance of the channels are nearly identical. Closely matched propagation delays allow the dual driver to be operated as a single driver if inputs and output pins are connected. The drive current capability in parallel operation is 2X the drive of either channel. Small differences in switching speed between the driver channels will produce a transient current (shoot-through) in the output stage when two output pins are connected to drive a single load. Differences in input thresholds between the driver channels will also produce a transient current (shoot-through) in the output stage. Fast transition input signals are especially important while operating in a parallel configuration. The efficiency loss for parallel operation has been characterized at various loads, supply voltages and operating frequencies. The power dissipation in the LM5110 increases by less than 1% relative to the dual driver configuration when operated as a single driver with inputs and outputs connected.

8.3.3 Turn-off with Negative Bias

The isolated input/output grounds provide the capability to drive the MOSFET to a negative VGS voltage for a more robust and reliable off state. In split supply configuration, the IN_REF pin is connected to the ground of the controller which drives the LM5110 inputs. The V_{EE} pin is connected to a negative bias supply that can range from the IN-REF as much as 14-V below the V_{CC} gate drive supply.

Enhancement mode MOSFETs do not inherently require a negative bias on the gate to turn off the FET. However, certain applications may benefit from the capability of negative VGS voltage during turnoff including:

1. When the gate voltages cannot be held safely below the threshold voltage due to transients or coupling in the printed-circuit-board.
2. When driving low threshold MOSFETs at high junction temperatures.
3. When high switching speeds produce capacitive gate-drain current that lifts the internal gate potential of the MOSFET.

8.3.4 UVLO and Power Supplies

An undervoltage lockout (UVLO) circuit is included in the LM5110, which senses the voltage difference between V_{CC} and the input ground pin, IN_REF. When the V_{CC} to IN_REF voltage difference falls below 2.7 V, both driver channels are disabled. The driver will resume normal operation when the V_{CC} to IN_REF differential voltage exceeds approximately 2.9 V. UVLO hysteresis prevents chattering during brown-out conditions.

The maximum recommended voltage difference between V_{CC} and IN_REF or between V_{CC} and V_{EE} is 14 V. The minimum voltage difference between V_{CC} and IN_REF is 3.5 V.

Feature Description (continued)

8.3.5 Shutdown $\overline{\text{SHDN}}$

The Shutdown pin ($\overline{\text{SHDN}}$) is a TTL compatible logic input provided to enable/disable both driver channels. When $\overline{\text{SHDN}}$ is in the logic low state, the LM5110 is switched to a low power standby mode with total supply current less than 25 μA . This function can be effectively used for start-up, thermal overload, or short circuit fault protection. TI recommends connecting this pin to V_{CC} when the shutdown function is not being used. The shutdown pin has an internal 18- μA current source pullup to V_{CC} .

8.4 Device Functional Modes

The device operates in normal mode and UVLO mode. See [Table 2](#) for more information on UVLO operation mode. In normal mode when the V_{CC} and $V_{\text{IN-REF}}$ are above UVLO threshold, the output stage is dependent on the states of the IN_A, IN_B and nSHDN pins. The output HO and LO will be low if input state is floating.

Table 2. INPUT/OUTPUT Logic Table

| IN_A ⁽¹⁾ | IN_B ⁽¹⁾ | $\overline{\text{SHDN}}$ | OUT_A ⁽²⁾ | OUT_B ⁽²⁾ |
|---------------------|---------------------|--------------------------|----------------------|----------------------|
| L | L | H or Left Open | L | L |
| L | H | H or Left Open | L | H |
| H | L | H or Left Open | H | L |
| H | H | H or Left Open | H | H |
| X | X | L | L | L |

(1) IN_A and IN_B is referenced to IN_REF.

(2) OUT_A and OUT_B is referenced to VEE.

9 Applications and Implementation

NOTE

Information in the following applications sections is not part of the TI component specification, and TI does not warrant its accuracy or completeness. TI's customers are responsible for determining suitability of components for their purposes. Customers should validate and test their design implementation to confirm system functionality.

9.1 Application Information

To operate fast switching of power MOSFETs at high switching frequencies and to reduce associated switching losses, a powerful gate driver is employed between the PWM output of controller and the gates of the power semiconductor devices. Also, gate drivers are indispensable when it is impossible for the PWM controller to directly drive the gates of the switching devices. With the advent of digital power, this situation is often encountered because the PWM signal from the digital controller is often a 3.3 V logic signal which cannot effectively turn on a power switch. Level shift circuit is needed to boost the 3.3 V signal to the gate-drive voltage (such as 12 V) in order to fully turn-on the power device and minimize conduction losses. Traditional buffer drive circuits based on NPN/PNP bipolar transistors in totem-pole arrangement prove inadequate with digital power because they lack level-shifting capability. Gate drivers effectively combine both the level-shifting and buffer-drive functions. Gate drivers also find other needs such as minimizing the effect of high-frequency switching noise (by placing the high-current driver IC physically close to the power switch), driving gate-drive transformers and controlling floating power-device gates, reducing power dissipation and thermal stress in controllers by moving gate charge power losses from the controller into the driver.

The LM5110 Dual Gate Driver replaces industry standard gate drivers with improved peak output current and efficiency. Each “compound” output driver stage includes MOS and bipolar transistors operating in parallel that together sink more than 5A peak from capacitive loads. Combining the unique characteristics of MOS and bipolar devices reduces drive current variation with voltage and temperature. Separate input and output ground pins provide Negative Drive Capability allowing the user to drive MOSFET gates with positive and negative VGS voltages.

9.2 Typical Application

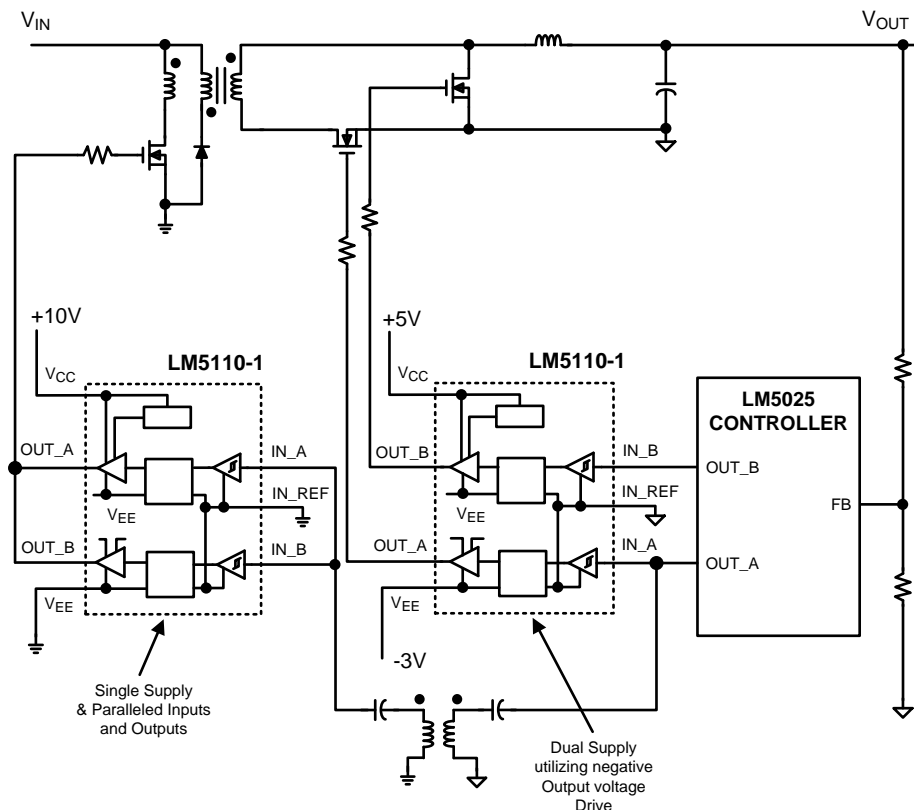

Copyright © 2016, Texas Instruments Incorporated

Figure 12. Simplified Power Converter Using Synchronous Rectifiers With Negative Off Gate Voltage

9.2.1 Design Requirements

To select proper device from LM5110 family, TI recommends first checking the appropriate logic for the outputs. LM5110-2 has dual inverting outputs; LM5110-1 has dual noninverting outputs; LM5110-3 have inverting channel A and noninverting channel B. Moreover, some design considerations must be evaluated first in order to make the most appropriate selection. Among these considerations are VCC, drive current, and power dissipation.

9.2.2 Detailed Design Procedure

9.2.2.1 Parallel Outputs

The A and B drivers may be combined into a single driver by connecting the INA/INB inputs together as close to the IC as possible, and the OUTA/OUTB outputs ties together if the external gate drive resistor is not used. In some cases where the external gate drive resistor is used, TI recommends that the resistor can be equally split in OUTA and OUTB respectively to reduce the parasitic inductance induce unbalance between two channels, as show in [Figure 13](#).

Typical Application (continued)

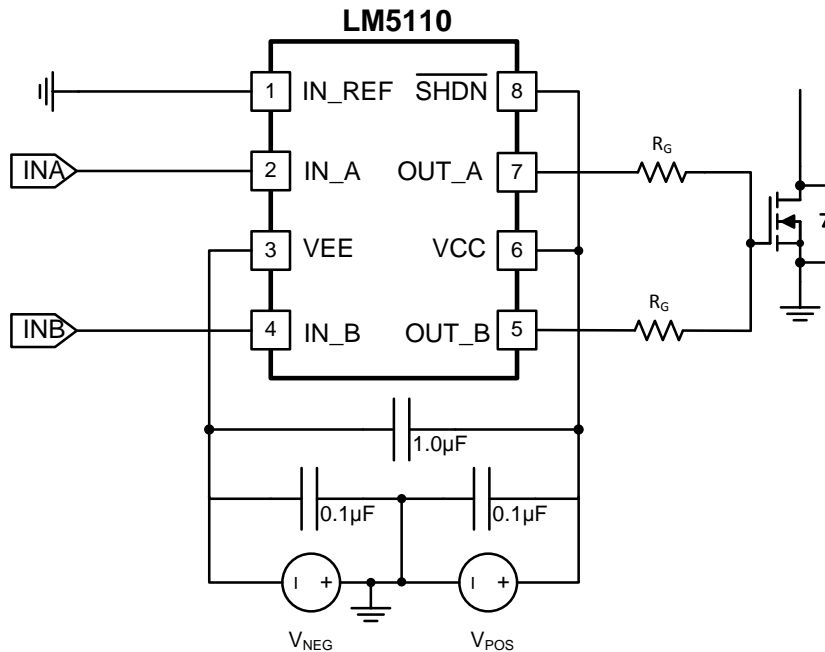

Copyright © 2016, Texas Instruments Incorporated

Figure 13. Parallel Operation of LM5110-1 and LM5110-2

Important consideration about paralleling two channels for LM5110 include: 1) IN_A and IN_B should be shorted in PCB layout as close to the device as possible, as well as for OUT_A and OUT_B, in which condition PCB layout parasitic mismatching between two channels could be minimized. 2) INA/B input slope signal should be fast enough to avoid mismatched V_{IH}/V_{IL} , t_{d1}/t_{d2} between channel-A and channel-B. TI recommends having input signal slope faster than 20 V/ μ s.

9.2.3 Application Curves

Figure 14 and Figure 15 shows the total operation current consumption vs load and frequency.

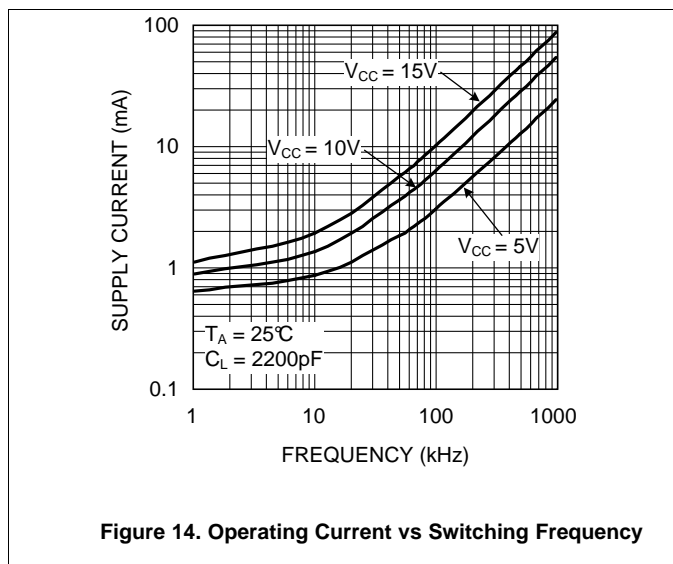

Figure 14. Operating Current vs Switching Frequency

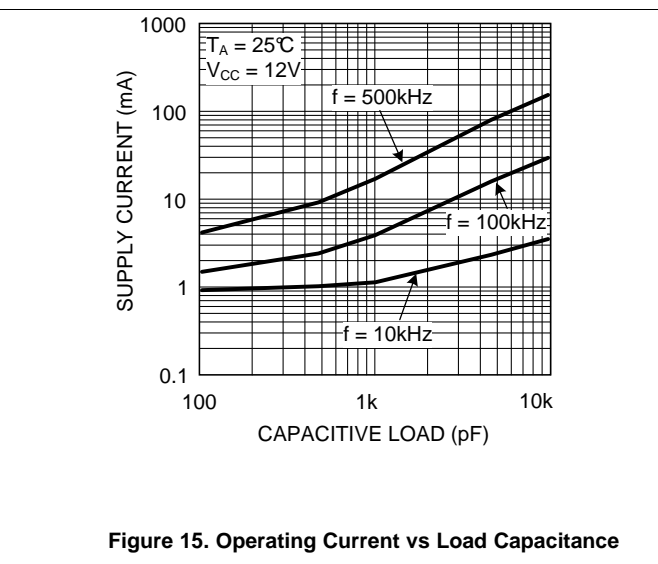

Figure 15. Operating Current vs Load Capacitance

10 Power Supply Recommendations

The recommended bias supply voltage range for LM5110 is from 3.5 V to 14 V. The upper end of this range is driven by the 15 V absolute maximum voltage rating of the VCC. TI recommends keeping proper margin to allow for transient voltage spikes.

A local bypass capacitor must be placed between the VCC and IN_REF pins, as well as between the VCC and VEE. This capacitor must be placed as close to the device as possible. A low ESR, ceramic surface mount capacitor is recommended. TI recommends using 2 capacitors in parallel: a 100-nF ceramic surface-mount capacitor for high frequency filtering placed as close to VCC as possible, and another surface-mount capacitor, 220 nF to 10 μ F, for IC bias requirements.

11 Layout

11.1 Layout Guidelines

Attention must be given to board layout when using LM5110. Some important considerations include:

1. A Low ESR/ESL capacitor must be connected close to the IC and between the V_{CC} and V_{EE} pins to support high peak currents being drawn from V_{CC} during turn-on of the MOSFET.
2. Proper grounding is crucial. The drivers need a very low impedance path for current return to ground avoiding inductive loops. The two paths for returning current to ground are a) between LM5110 IN-REF pin and the ground of the circuit that controls the driver inputs, b) between LM5110 V_{EE} pin and the source of the power MOSFET being driven. All these paths should be as short as possible to reduce inductance and be as wide as possible to reduce resistance. All these ground paths should be kept distinctly separate to avoid coupling between the high current output paths and the logic signals that drive the LM5110. A good method is to dedicate one copper plane in a multi-layered PCB to provide a common ground surface.
3. With the rise and fall times in the range of 10 ns to 30 ns, care is required to minimize the lengths of current carrying conductors to reduce their inductance and EMI from the high di/dt transients generated by the LM5110.
4. The LM5110 SOIC footprint is compatible with other industry standard drivers. Simply connect IN_REF pin of the LM5110 to V_{EE} (pin 1 to pin 3) to operate the LM5110 in a standard single supply configuration.
5. If either channel is not being used, the respective input pin (IN_A or IN_B) should be connected to either IN_REF or V_{CC} to avoid spurious output signals. If the shutdown feature is not used, the nSHDN pin should be connected to V_{CC} to avoid erratic behavior that would result if system noise were coupled into a floating 'nSHDN' pin.

11.2 Layout Example

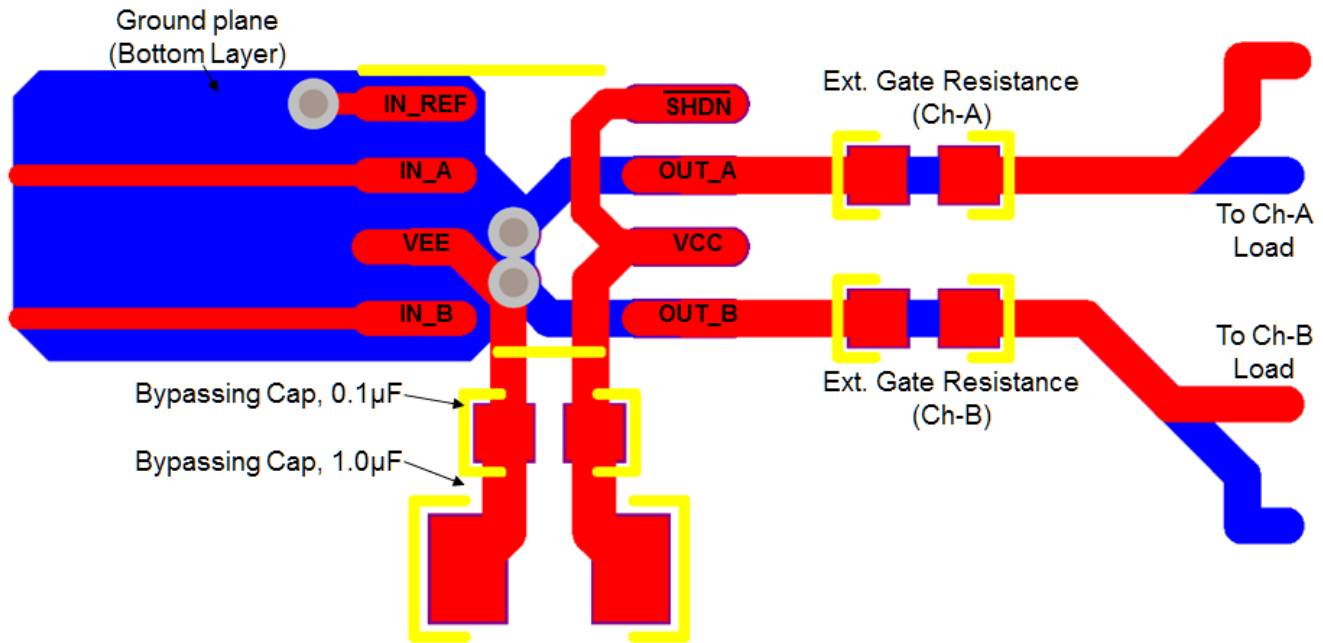

Figure 16. SOIC(8) Layout Example

11.3 Thermal Considerations

The primary goal of thermal management is to maintain the integrated circuit (IC) junction temperature (T_J) below a specified maximum operating temperature to ensure reliability. It is essential to estimate the maximum T_J of IC components in worst case operating conditions. The junction temperature is estimated based on the power dissipated in the IC and the junction to ambient thermal resistance θ_{JA} for the IC package in the application board and environment. The θ_{JA} is not a given constant for the package and depends on the printed circuit board design and the operating environment.

11.3.1 Drive Power Requirement Calculations in LM5110

The LM5110 dual low side MOSFET driver is capable of sourcing/sinking 3-A/5-A peak currents for short intervals to drive a MOSFET without exceeding package power dissipation limits. High peak currents are required to switch the MOSFET gate very quickly for operation at high frequencies.

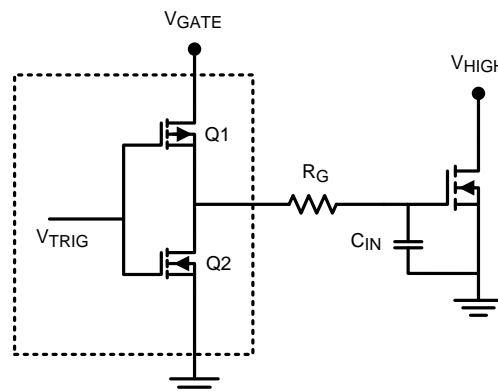

Figure 17. LM5110 drives MOSFET with Driver Output Stage and MOSFET Gate-Source Capacitance

Thermal Considerations (continued)

The schematic above shows a conceptual diagram of the LM5110 output and MOSFET load. Q1 and Q2 are the switches within the gate driver. R_G is the gate resistance of the external MOSFET, and C_{IN} is the equivalent gate capacitance of the MOSFET. The gate resistance R_G is usually very small and losses in it can be neglected. The equivalent gate capacitance is a difficult parameter to measure since it is the combination of C_{GS} (gate to source capacitance) and C_{GD} (gate to drain capacitance). Both of these MOSFET capacitances are not constants and vary with the gate and drain voltage. The better way of quantifying gate capacitance is the total gate charge Q_G in coulombs. Q_G combines the charge required by C_{GS} and C_{GD} for a given gate drive voltage V_{GATE} .

Assuming negligible gate resistance, the total power dissipated in the MOSFET driver due to gate charge is approximated by

$$P_{DRIVER} = V_{GATE} \times Q_G \times F_{SW}$$

where

- F_{SW} = switching frequency of the MOSFET (1)

As an example, consider the MOSFET MTD6N15 whose gate charge specified as 30 nC for $V_{GATE} = 12$ V.

The power dissipation in the driver due to charging and discharging of MOSFET gate capacitances at switching frequency of 300 kHz and V_{GATE} of 12 V is equal to

$$P_{DRIVER} = 12 \text{ V} \times 30 \text{ nC} \times 300 \text{ kHz} = 0.108 \text{ W.} \quad (2)$$

If both channels of the LM5110 are operating at equal frequency with equivalent loads, the total losses will be twice as this value which is 0.216 W.

In addition to the above gate charge power dissipation, - transient power is dissipated in the driver during output transitions. When either output of the LM5110 changes state, current will flow from V_{CC} to V_{EE} for a very brief interval of time through the output totem-pole N and P channel MOSFETs. The final component of power dissipation in the driver is the power associated with the quiescent bias current consumed by the driver input stage and undervoltage lockout sections.

Characterization of the LM5110 provides accurate estimates of the transient and quiescent power dissipation components. At 300-kHz switching frequency and 30-nC load used in the example, the transient power will be 8 mW. The 1-mA nominal quiescent current and 12-V V_{GATE} supply produce a 12-mW typical quiescent power.

Therefore the total power dissipation

$$P_D = 0.216 + 0.008 + 0.012 = 0.236 \text{ W.} \quad (3)$$

We know that the junction temperature is given by

$$T_J = P_D \times \theta_{JA} + T_A \quad (4)$$

Or the rise in temperature is given by

$$T_{RISE} = T_J - T_A = P_D \times \theta_{JA} \quad (5)$$

For SOIC-8 package θ_{JA} is estimated as 114°C/W see [Thermal Information](#) section.

Therefore T_{RISE} is equal to

$$T_{RISE} = 0.236 \times 114 \approx 27^\circ\text{C} \quad (6)$$

For WSON-10 package, the integrated circuit die is attached to leadframe die pad which is soldered directly to the printed circuit board. This substantially decreases the junction to ambient thermal resistance (θ_{JA}). θ_{JA} as low as 40°C/W is achievable with the WSON10 package. The resulting T_{RISE} for the dual driver example above is thereby reduced to just 9.5°.

11.3.2 Continuous Current Rating of LM5110

The LM5110 can deliver pulsed source/sink currents of 3 A and 5 A to capacitive loads. In applications requiring continuous load current (resistive or inductive loads), package power dissipation, limits the LM5110 current capability far below the 5-A sink/3-A source capability. Rated continuous current can be estimated both when sourcing current to or sinking current from the load. For example when sinking, the maximum sink current can be calculated using [Equation 7](#).

$$I_{SINK}(\text{MAX}) := \sqrt{\frac{T_J(\text{MAX}) - T_A}{\theta_{JA} \cdot R_{DS}(\text{ON})}}$$

Thermal Considerations (continued)

where

- $R_{DS(on)}$ is the on resistance of lower MOSFET in the output stage of LM5110. (7)

Consider $T_J(max)$ of 125°C and θ_{JA} of 114°C/W for an SO-8 package under the condition of natural convection and no air flow. If the ambient temperature (T_A) is 60°C, and the $R_{DS(on)}$ of the LM5110 output at $T_J(max)$ is 2.5 Ω , this equation yields $I_{SINK(max)}$ of 478 mA which is much smaller than 5-A peak pulsed currents.

Similarly, the maximum continuous source current can be calculated as

$$I_{SOURCE (MAX)} := \frac{T_J(MAX) - T_A}{\theta_{JA} \cdot V_{DIODE}}$$

where

- V_{DIODE} is the voltage drop across hybrid output stage which varies over temperature and can be assumed to be about 1.1 V at $T_J(max)$ of 125°C (8)

Assuming the same parameters as above, this equation yields $I_{SOURCE(max)}$ of 518 mA.

12 Device and Documentation Support

12.1 Receiving Notification of Documentation Updates

To receive notification of documentation updates, navigate to the device product folder on ti.com. In the upper right corner, click on *Alert me* to register and receive a weekly digest of any product information that has changed. For change details, review the revision history included in any revised document.

12.2 Community Resources

The following links connect to TI community resources. Linked contents are provided "AS IS" by the respective contributors. They do not constitute TI specifications and do not necessarily reflect TI's views; see TI's [Terms of Use](#).

TI E2E™ Online Community *TI's Engineer-to-Engineer (E2E) Community*. Created to foster collaboration among engineers. At e2e.ti.com, you can ask questions, share knowledge, explore ideas and help solve problems with fellow engineers.

Design Support *TI's Design Support* Quickly find helpful E2E forums along with design support tools and contact information for technical support.

12.3 Trademarks

E2E is a trademark of Texas Instruments.
All other trademarks are the property of their respective owners.

12.4 Electrostatic Discharge Caution



These devices have limited built-in ESD protection. The leads should be shorted together or the device placed in conductive foam during storage or handling to prevent electrostatic damage to the MOS gates.

12.5 Glossary

[SLYZ022](#) — *TI Glossary*.

This glossary lists and explains terms, acronyms, and definitions.

13 Mechanical, Packaging, and Orderable Information

The following pages include mechanical, packaging, and orderable information. This information is the most current data available for the designated devices. This data is subject to change without notice and revision of this document. For browser-based versions of this data sheet, refer to the left-hand navigation.

TAPE AND REEL INFORMATION

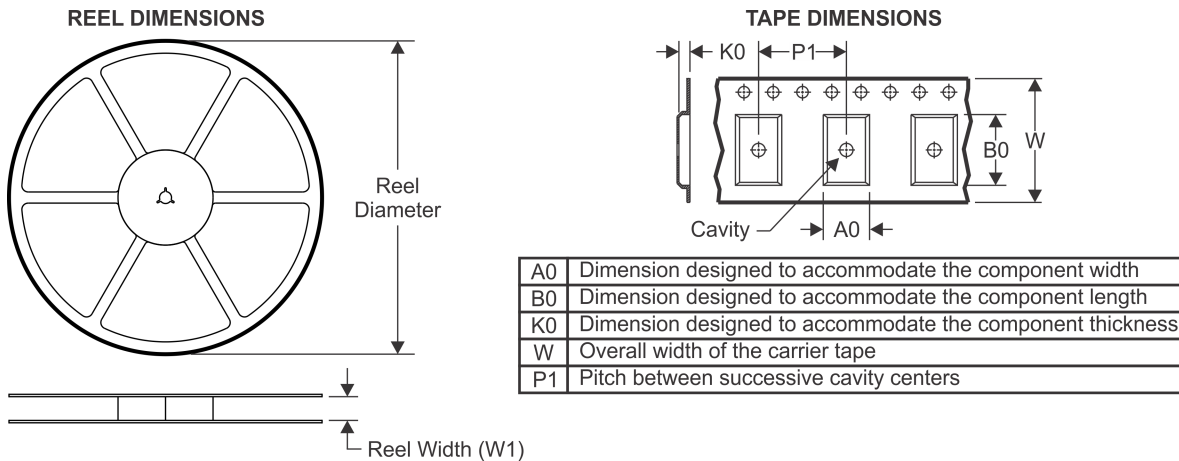

QUADRANT ASSIGNMENTS FOR PIN 1 ORIENTATION IN TAPE



*All dimensions are nominal

| Device | Package Type | Package Drawing | Pins | SPQ | Reel Diameter (mm) | Reel Width W1 (mm) | A0 (mm) | B0 (mm) | K0 (mm) | P1 (mm) | W (mm) | Pin1 Quadrant |
|------------------|--------------|-----------------|------|------|--------------------|--------------------|---------|---------|---------|---------|--------|---------------|
| LM5110-1MX/NOPB | SOIC | D | 8 | 2500 | 330.0 | 12.4 | 6.5 | 5.4 | 2.0 | 8.0 | 12.0 | Q1 |
| LM5110-1SD | WSON | DPR | 10 | 1000 | 178.0 | 12.4 | 4.3 | 4.3 | 1.3 | 8.0 | 12.0 | Q1 |
| LM5110-1SD/NOPB | WSON | DPR | 10 | 1000 | 180.0 | 12.4 | 4.3 | 4.3 | 1.1 | 8.0 | 12.0 | Q1 |
| LM5110-1SDX/NOPB | WSON | DPR | 10 | 4500 | 330.0 | 12.4 | 4.3 | 4.3 | 1.3 | 8.0 | 12.0 | Q1 |
| LM5110-2MX/NOPB | SOIC | D | 8 | 2500 | 330.0 | 12.4 | 6.5 | 5.4 | 2.0 | 8.0 | 12.0 | Q1 |
| LM5110-2SD/NOPB | WSON | DPR | 10 | 1000 | 180.0 | 12.4 | 4.3 | 4.3 | 1.1 | 8.0 | 12.0 | Q1 |
| LM5110-2SD/NOPB | WSON | DPR | 10 | 1000 | 178.0 | 12.4 | 4.3 | 4.3 | 1.3 | 8.0 | 12.0 | Q1 |
| LM5110-3MX/NOPB | SOIC | D | 8 | 2500 | 330.0 | 12.4 | 6.5 | 5.4 | 2.0 | 8.0 | 12.0 | Q1 |
| LM5110-3SD | WSON | DPR | 10 | 1000 | 178.0 | 12.4 | 4.3 | 4.3 | 1.3 | 8.0 | 12.0 | Q1 |
| LM5110-3SD/NOPB | WSON | DPR | 10 | 1000 | 178.0 | 12.4 | 4.3 | 4.3 | 1.3 | 8.0 | 12.0 | Q1 |
| LM5110-3SDX/NOPB | WSON | DPR | 10 | 4500 | 330.0 | 12.4 | 4.3 | 4.3 | 1.3 | 8.0 | 12.0 | Q1 |

TAPE AND REEL BOX DIMENSIONS

*All dimensions are nominal

| Device | Package Type | Package Drawing | Pins | SPQ | Length (mm) | Width (mm) | Height (mm) |
|------------------|--------------|-----------------|------|------|-------------|------------|-------------|
| LM5110-1MX/NOPB | SOIC | D | 8 | 2500 | 367.0 | 367.0 | 35.0 |
| LM5110-1SD | WSON | DPR | 10 | 1000 | 210.0 | 185.0 | 35.0 |
| LM5110-1SD/NOPB | WSON | DPR | 10 | 1000 | 203.0 | 203.0 | 35.0 |
| LM5110-1SDX/NOPB | WSON | DPR | 10 | 4500 | 367.0 | 367.0 | 35.0 |
| LM5110-2MX/NOPB | SOIC | D | 8 | 2500 | 367.0 | 367.0 | 35.0 |
| LM5110-2SD/NOPB | WSON | DPR | 10 | 1000 | 203.0 | 203.0 | 35.0 |
| LM5110-2SD/NOPB | WSON | DPR | 10 | 1000 | 210.0 | 185.0 | 35.0 |
| LM5110-3MX/NOPB | SOIC | D | 8 | 2500 | 367.0 | 367.0 | 35.0 |
| LM5110-3SD | WSON | DPR | 10 | 1000 | 210.0 | 185.0 | 35.0 |
| LM5110-3SD/NOPB | WSON | DPR | 10 | 1000 | 210.0 | 185.0 | 35.0 |
| LM5110-3SDX/NOPB | WSON | DPR | 10 | 4500 | 367.0 | 367.0 | 35.0 |

DPR (S-PWSON-N10)

PLASTIC SMALL OUTLINE NO-LEAD

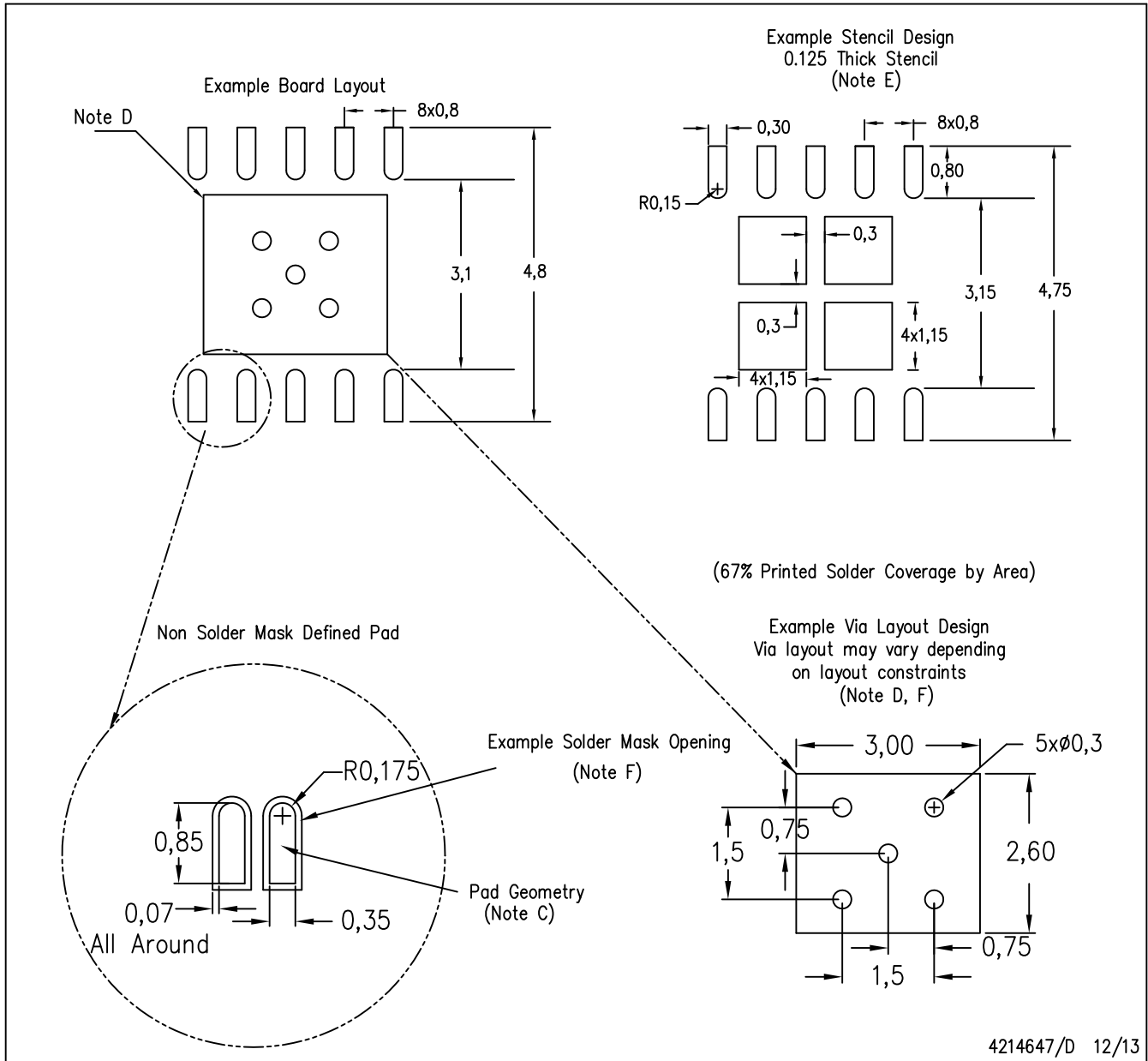

- NOTES:
- All linear dimensions are in millimeters.
 - This drawing is subject to change without notice.
 - Publication IPC-7351 is recommended for alternate designs.
 - This package is designed to be soldered to a thermal pad on the board. Refer to Application Note, Quad Flat-Pack Packages, Texas Instruments Literature No. SLUA271, and also the Product Data Sheets for specific thermal information, via requirements, and recommended board layout. These documents are available at www.ti.com <<http://www.ti.com>>.
 - Laser cutting apertures with trapezoidal walls and also rounding corners will offer better paste release. Customers should contact their board assembly site for stencil design recommendations. Refer to IPC 7525 for stencil design considerations.
 - Customers should contact their board fabrication site for recommended solder mask tolerances and via tenting recommendations for vias placed in the thermal pad.



D0008A

PACKAGE OUTLINE

SOIC - 1.75 mm max height

SMALL OUTLINE INTEGRATED CIRCUIT



4214825/C 02/2019

NOTES:

1. Linear dimensions are in inches [millimeters]. Dimensions in parenthesis are for reference only. Controlling dimensions are in inches. Dimensioning and tolerancing per ASME Y14.5M.
2. This drawing is subject to change without notice.
3. This dimension does not include mold flash, protrusions, or gate burrs. Mold flash, protrusions, or gate burrs shall not exceed $.006$ [0.15] per side.
4. This dimension does not include interlead flash.
5. Reference JEDEC registration MS-012, variation AA.

EXAMPLE BOARD LAYOUT

D0008A

SOIC - 1.75 mm max height

SMALL OUTLINE INTEGRATED CIRCUIT



LAND PATTERN EXAMPLE
 EXPOSED METAL SHOWN
 SCALE:8X



SOLDER MASK DETAILS

4214825/C 02/2019

NOTES: (continued)

- 6. Publication IPC-7351 may have alternate designs.
- 7. Solder mask tolerances between and around signal pads can vary based on board fabrication site.

EXAMPLE STENCIL DESIGN

D0008A

SOIC - 1.75 mm max height

SMALL OUTLINE INTEGRATED CIRCUIT



SOLDER PASTE EXAMPLE
BASED ON .005 INCH [0.125 MM] THICK STENCIL
SCALE:8X

4214825/C 02/2019

NOTES: (continued)

8. Laser cutting apertures with trapezoidal walls and rounded corners may offer better paste release. IPC-7525 may have alternate design recommendations.
9. Board assembly site may have different recommendations for stencil design.

IMPORTANT NOTICE AND DISCLAIMER

TI PROVIDES TECHNICAL AND RELIABILITY DATA (INCLUDING DATASHEETS), DESIGN RESOURCES (INCLUDING REFERENCE DESIGNS), APPLICATION OR OTHER DESIGN ADVICE, WEB TOOLS, SAFETY INFORMATION, AND OTHER RESOURCES "AS IS" AND WITH ALL FAULTS, AND DISCLAIMS ALL WARRANTIES, EXPRESS AND IMPLIED, INCLUDING WITHOUT LIMITATION ANY IMPLIED WARRANTIES OF MERCHANTABILITY, FITNESS FOR A PARTICULAR PURPOSE OR NON-INFRINGEMENT OF THIRD PARTY INTELLECTUAL PROPERTY RIGHTS.

These resources are intended for skilled developers designing with TI products. You are solely responsible for (1) selecting the appropriate TI products for your application, (2) designing, validating and testing your application, and (3) ensuring your application meets applicable standards, and any other safety, security, or other requirements. These resources are subject to change without notice. TI grants you permission to use these resources only for development of an application that uses the TI products described in the resource. Other reproduction and display of these resources is prohibited. No license is granted to any other TI intellectual property right or to any third party intellectual property right. TI disclaims responsibility for, and you will fully indemnify TI and its representatives against, any claims, damages, costs, losses, and liabilities arising out of your use of these resources.

TI's products are provided subject to TI's Terms of Sale (www.ti.com/legal/termsofsale.html) or other applicable terms available either on ti.com or provided in conjunction with such TI products. TI's provision of these resources does not expand or otherwise alter TI's applicable warranties or warranty disclaimers for TI products.

Mailing Address: Texas Instruments, Post Office Box 655303, Dallas, Texas 75265
Copyright © 2019, Texas Instruments Incorporated

Looking for pricing, stock, or lifecycle information?

Click below to explore more details on WIN SOURCE:

 [View LM5110-3MX/NOPB on WIN SOURCE](#)

 [Texas Instruments](#) Information

Optimize Your Supply Chain with WIN SOURCE Solutions

-  Global Sourcing Solution
-  Obsolete Management
-  Cost Control Management
-  Shortage Management
-  Alternative Solution
-  Excess Inventory Management