



**THE DATASHEET OF
LM5071MT-50**



LM5071 Power Over Ethernet PD Controller with Auxiliary Power Interface

Check for Samples: [LM5071](#)

FEATURES

- Compatible with 12V AC Adapters
- Fully Compliant 802.3af Power Interface Port
- 80V, 1 Ω , 400 mA Internal MOSFET
- Detection Resistor Disconnect Function
- Programmable Classification Current
- Programmable Under-voltage Lockout with Programmable Hysteresis
- Thermal Shutdown Protection
- Auxiliary Power Enable Pin
- Current Mode Pulse Width Modulator
- Supports both Isolated and Non-Isolated Applications
- Error Amplifier and Reference for Non-Isolated Applications
- Programmable Oscillator Frequency
- Programmable Soft-Start
- 80% Maximum Duty Cycle Limiter, Slope Compensation (-80 device)
- 50% Maximum Duty Cycle Limiter, No Slope Compensation (-50 device)

PACKAGES

- TSSOP-16

DESCRIPTION

The LM5071 power interface port and pulse width modulation (PWM) controller provides a complete integrated solution for Powered Devices (PD) that connect into Power over Ethernet (PoE) systems. **The LM5071 is specifically designed for the PD that must accept power from auxiliary sources such as AC adapters.** The auxiliary power interface of the LM5071 activates the PWM controller when the ac adapter is connected to power the PD when PoE network power is unavailable. The LM5071 integrates an 80V, 400mA line connection switch and associated control for a fully IEEE 802.3af compliant interface with a full featured current mode pulse width modulator dc-dc converter. All power sequencing requirements between the controller interface and switch mode power supply (SMPS) are integrated into the IC.

Block Diagram

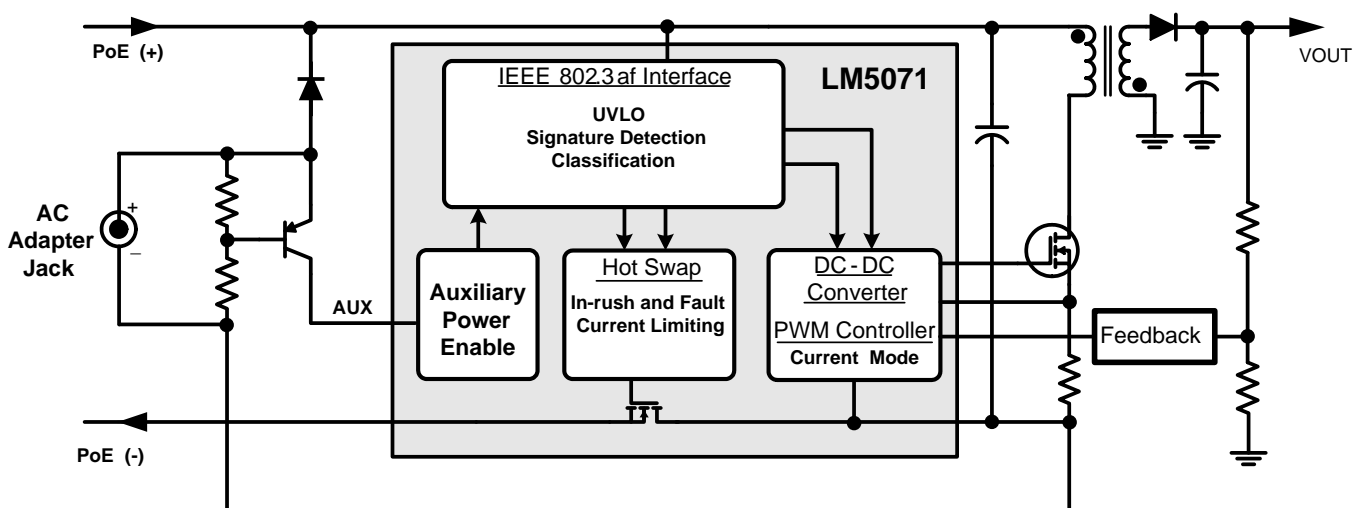

Please be aware that an important notice concerning availability, standard warranty, and use in critical applications of Texas Instruments semiconductor products and disclaimers thereto appears at the end of this data sheet.

All trademarks are the property of their respective owners.

PRODUCTION DATA information is current as of publication date. Products conform to specifications per the terms of the Texas Instruments standard warranty. Production processing does not necessarily include testing of all parameters.

Copyright © 2005–2013, Texas Instruments Incorporated

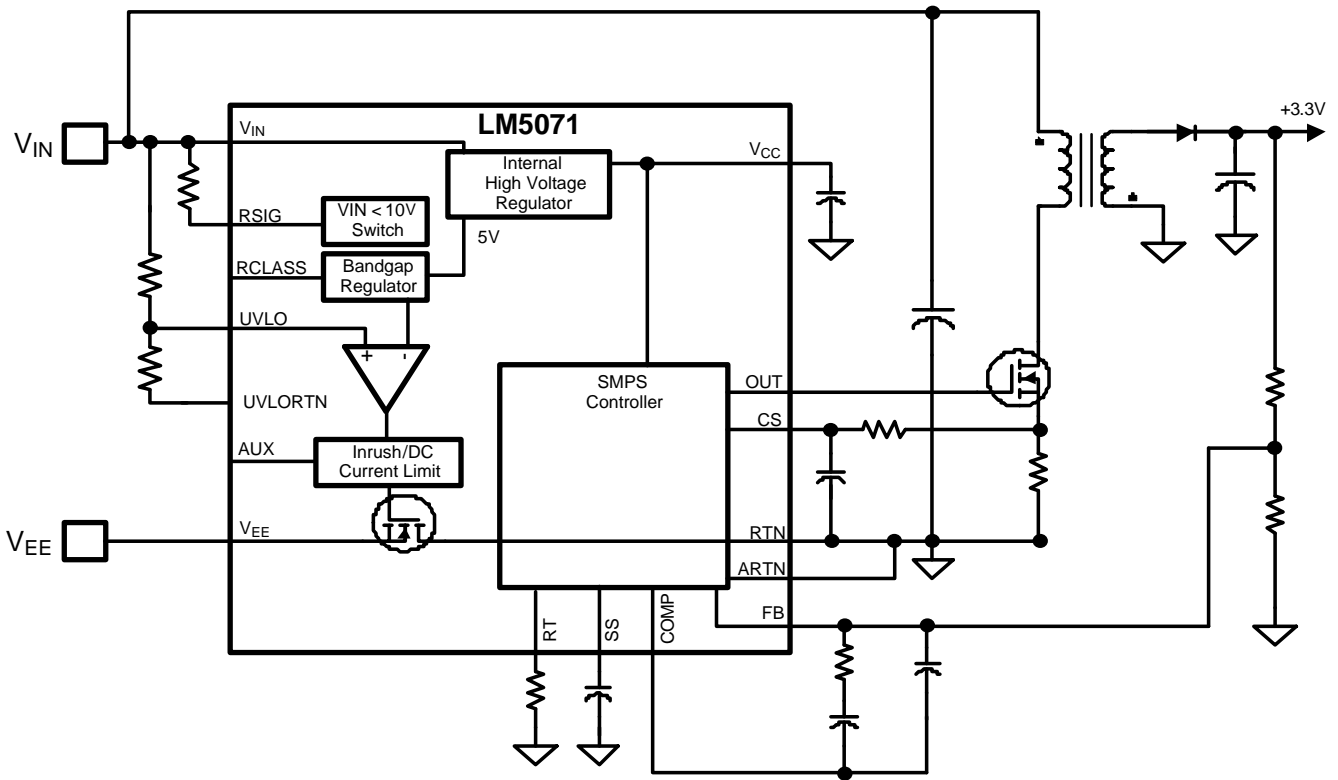

Figure 1. Simplified Block Diagram

Connection Diagram

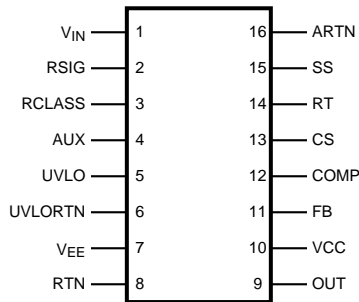

Figure 2. 16 Lead TSSOP

PIN DESCRIPTIONS

Pin	Name	Description	Application Information
1	VIN	System high potential input.	The diode "OR" of several lines entering the PD, it is the more positive input potential.
2	RSIG	Signature resistor pin.	Connect a resistor from V_{IN} to this pin for signature detection. The resistor is in parallel with the UVLO resistors and should be valued accordingly.
3	RCLASS	Classification resistor pin.	Connect the classification programming resistor from this pin to V_{EE} .
4	AUX	Auxiliary input power startup pin.	A resistor divider between the AUX voltage input to V_{EE} programs the startup levels with a 2.5V threshold. A high value (>300k Ω) internal pull down resistor is present to pull the pin low if it is left open. In practice, the divider voltage should be set well above 2.5V by the programming resistors.
5	UVLO	Line under-voltage lockout.	An external resistor divider from V_{IN} to UVLORTN programs the shutdown levels with a 2.00V threshold at the UVLO pin. Hysteresis is set by a switched internal 10 μ A current source that forces additional current into the resistor divider.
6	UVLORTN	Return for the external UVLO resistors.	Connect the bottom resistor of the resistor divider between the UVLO pin and this pin.
7	VEE	System low potential input.	Diode "OR'd" to the RJ45 connector and PSE's -48V supply, it is the more negative input potential.
8	RTN	System return for the PWM converter.	The drain of the internal current limiting power MOSFET which connects V_{EE} to the return path of the dc-dc converter.
9	OUT	Output of the PWM controller.	DC-DC converter gate driver output with 800mA peak sink current capability.
10	V_{CC}	Output of the internal high voltage series pass regulator. Regulated output voltage is nominally 7.8V.	When the auxiliary transformer winding (if used) raises the voltage on this pin above the regulation set point, the internal series pass regulator will shutdown, reducing the controller power dissipation.
11	FB	Feedback signal.	Inverting input of the internal error amplifier. The non-inverting input is internally connected to a 1.25V reference.
12	COMP	The output of the error amplifier and input to the Pulse Width Modulator.	COMP pull-up is provided by an internal 5K resistor which may be used to bias an opto-coupler transistor.
13	CS	Current sense input.	Current sense input for current mode control and over-current protection. Current limiting is accomplished using a dedicated current sense comparator. If the CS pin voltage exceeds 0.5V the OUT pin switches low for cycle-by-cycle current limiting. CS is held low for 50ns after OUT switches high to blank leading edge current spikes.
14	RT / SYNC	Oscillator timing resistor pin and synchronization input.	An external resistor connected from RT to ARTN sets the oscillator frequency. This pin will also accept narrow ac-coupled synchronization pulses from an external clock.
15	SS	Soft-start input.	An external capacitor and an internal 10 μ A current source set the soft-start ramp rate.
16	ARTN	Analog PWM supply return.	RTN for sensitive analog circuitry including the SMPS current limit amplifier.



These devices have limited built-in ESD protection. The leads should be shorted together or the device placed in conductive foam during storage or handling to prevent electrostatic damage to the MOS gates.

Absolute Maximum Ratings⁽¹⁾⁽²⁾

V_{IN} , RTN to V_{EE}		-0.3V to 80V
RSIG to V_{IN}		-12V to 0V
AUX to V_{EE}		-0.3V to 57V
UVLO to V_{EE}		-0.3V to 13V
RCLASS to V_{EE}		-0.3V to 7V
ARTN to RTN		-0.3V to 0.3V
V_{CC} , OUT to ARTN		-0.3V to 16V
All other inputs to ARTN		-0.3V to 7V
ESD Rating	Human Body Model	2000V
Lead Temperature ⁽³⁾	Wave (4 seconds)	260°C
	Infrared (10 seconds)	240°C
	Vapor Phase (75 seconds)	219°C

- (1) Absolute Maximum Ratings are limits beyond which damage to the device may occur. Operating Ratings are conditions under which operation of the device is intended to be functional. For specifications and test conditions, see [Electrical Characteristics](#). The absolute maximum rating of V_{IN} , RTN to V_{EE} is derated to (-0.3V to 76V) at -40°C.
- (2) If Military/Aerospace specified devices are required, please contact the Texas Instruments Sales Office/Distributors for availability and specifications.
- (3) For detailed information on soldering the plastic TSSOP package, refer to the Packaging Databook available from Texas Instruments.

Operating Ratings

V_{IN} voltage	1.8V to 60V
External voltage applied to V_{CC}	8.1V to 15V
Operating Junction Temperature	-40°C to 125°C

Electrical Characteristics⁽¹⁾

Specifications in standard type face are for $T_J = +25^\circ\text{C}$ and those in **boldface type** apply over the full operating junction temperature range. Unless otherwise specified: $V_{IN} = 48\text{V}$, $V_{CC} = 10\text{V}$, $RT = 30.3\text{k}\Omega$.

Symbol	Parameter	Conditions	Min	Typ	Max	Units
Powered Interface						
IOS	Offset Current	$V_{IN} < 10.0\text{V}$			10	μA
VCLSS(ON)	Signature Resistor Disable / Classification Current Turn On	V_{IN} with respect to V_{EE}	10.0	11.5	12.5	V
VCLSS(OFF)	Classification Current Turn Off	V_{IN} with respect to V_{EE}	23.5	25.0	26.5	V
	Classification Voltage	With respect to V_{EE}	1.43	1.5	1.57	V
ICLASS	Supply Current During Classification	$V_{IN} = 17\text{V}$		0.5	1.0	mA
IDC	Supply Current During Normal Operation	OUT floating		1	1.9	mA
	UVLO Pin Reference Voltage	$V_{IN} > 27\text{V}$	1.95	2.00	2.05	V
	UVLO Hysteresis Current	$V_{IN} > \text{UVLO}$	8.0	10	11.5	μA
	Softstart Release	RTN falling with respect to V_{EE}	1.2	1.45	1.7	V
	Softstart Release Hysteresis	RTN rising with respect to V_{EE}	0.8	1.1	1.3	V
RDS(ON)	PowerFET Resistance	$I = 350\text{mA}$, $V_{IN} = 48\text{V}$		1	2.2	Ω
ILEAK	SMPS Bias Current	$V_{EE} = 0\text{V}$, $V_{IN} = \text{RTN} = 57\text{V}$			100	μA
	AUX Pin Threshold	AUX pin rising with respect to V_{EE}	2.4	2.5	2.65	V
	AUX Pin Threshold Hysteresis	AUX pin falling with respect to V_{EE}	0.4	0.5	0.6	V
ZAUX	AUX Pin Input Impedance	AUX = 0.5V		350		k Ω
I_{INRUSH}	Inrush Current Limit	$V_{EE} = 0\text{V}$, RTN = 3.0V	70	100	130	mA
ILIM	DC Current Limit	$V_{EE} = 0\text{V}$, RTN = 3.0V, Temp = 0°C to 85°C	350	390	420	mA
ILIM	DC Current Limit	$V_{EE} = 0\text{V}$, RTN = 3.0V, Temp = -40°C to 125°C	325	390	420	mA
Startup Regulator						
VinMin	Operational VIN Input Voltage	AUX = 5V, $V_{CC} = V_{in}^{(2)}$	9.5			V
VccReg	V_{CC} Regulation	Open ckt	7.5	7.8	8.1	V
	V_{CC} Current Limit	See ⁽³⁾	15	20		mA
V_{CC} Supply						
	V_{CC} UVLO (Rising)		VccReg – 300mV	$V_{CCReg} - 100\text{mV}$		
	V_{CC} UVLO (Falling)		5.9	6.25	6.6	V
	Supply Current (I_{CC})	Clload = 0		1.5	3	mA
Error Amplifier						
GBW	Gain Bandwidth			4		MHz
	DC Gain			75		dB
	Input Voltage	FB = COMP	1.219 1.212		1.281 1.288	V
	COMP Sink Capability	FB=1.5V COMP=1V	5	20		mA
Current Limit						
	ILIM Delay to Output	CS step from 0 to 0.6V, time to onset of OUT transition (90%)		20		ns
	Cycle by Cycle Current Limit Threshold Voltage		0.44	0.5	0.56	V

- (1) Min and Max limits are 100% production tested at 25°C . Limits over the operating temperature range are specified through correlation using Statistical Quality Control (SQC) methods. Limits are used to calculate Texas Instruments' Average Outgoing Quality Level (AOQL).
- (2) The V_{CC} regulator requires an external source whenever the Vin pin is below 13V with respect to RTN. An external load on V_{CC} increases this startup voltage requirement.
- (3) Device thermal limitations may limit usable range.

Electrical Characteristics⁽¹⁾ (continued)

Specifications in standard type face are for $T_J = +25^\circ\text{C}$ and those in **boldface type** apply over the full operating junction temperature range. Unless otherwise specified: $V_{IN} = 48\text{V}$, $V_{CC} = 10\text{V}$, $RT = 30.3\text{k}\Omega$.

Symbol	Parameter	Conditions	Min	Typ	Max	Units
	Leading Edge Blanking Time			55		ns
	CS Sink Impedance (clocked)			25	55	Ω
Soft-Start						
	Softstart Current Source		7	10	13	μA
Oscillator⁽⁴⁾						
	Frequency1 (RT = 30.3K)		175	200	225	KHz
	Frequency2 (RT = 10.5K)		505	580	665	KHz
	Sync threshold			3.1	3.8	V
PWM Comparator						
	Delay to Output	COMP set to 2V CS stepped 0 to 0.4V, time to onset of OUT transition low		25		ns
	Min Duty Cycle	COMP=0V			0	%
	Max Duty Cycle (-80 Device)			80		%
	Max Duty Cycle (-50 Device)			50		%
	COMP to PWM Comparator Gain			0.33		
	COMP Open Circuit Voltage		4.5	5.4	6.3	V
	COMP Short Circuit Current	COMP= 0V	0.6	1.1	1.5	mA
Slope Compensation						
	Slope Comp Amplitude (LM5071-80 Device Only)	Delta increase at PWM Comparator to CS		105		mV
Output Section						
	Output High Saturation	$I_{out} = 50\text{mA}$, $V_{CC} - V_{OUT}$		0.25	0.75	V
	Output Low Saturation	$I_{out} = 100\text{mA}$		0.25	0.75	V
	Rise time	Clload = 1nF		15		ns
	Fall time	Clload = 1nF		15		ns
Thermal Shutdown						
Tsd	Thermal Shutdown Temp.			165		$^\circ\text{C}$
Thermal Shutdown Hysteresis				25		$^\circ\text{C}$
Thermal Resistance						
θ_{JA}	Junction to Ambient	PW Package		125		$^\circ\text{C/W}$

(4) Specification applies to the oscillator frequency. The operational frequency of the LM5071-50 devices is divided by two.

Typical Performance Characteristics

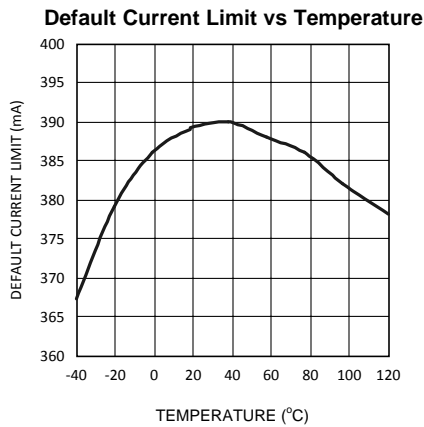

Figure 3.

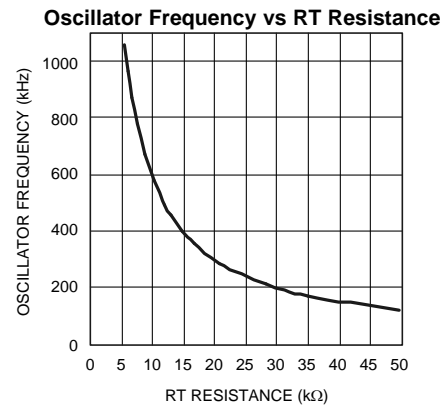

Figure 4.

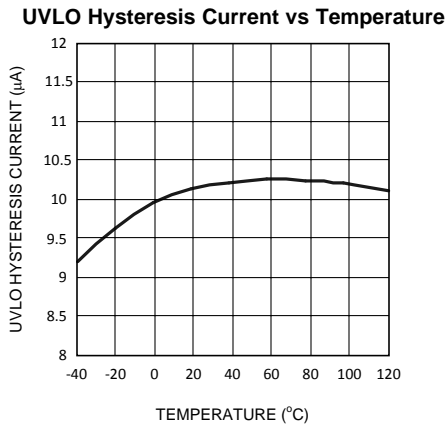

Figure 5.

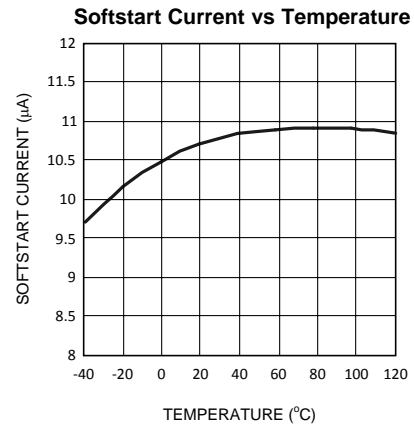

Figure 6.

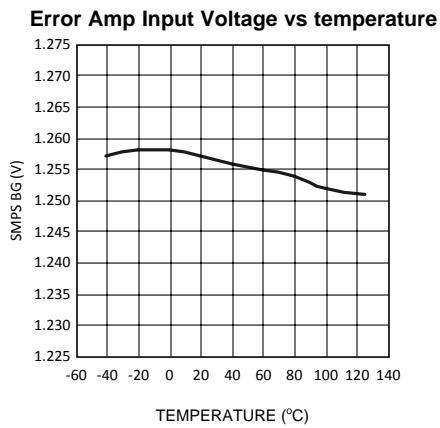

Figure 7.

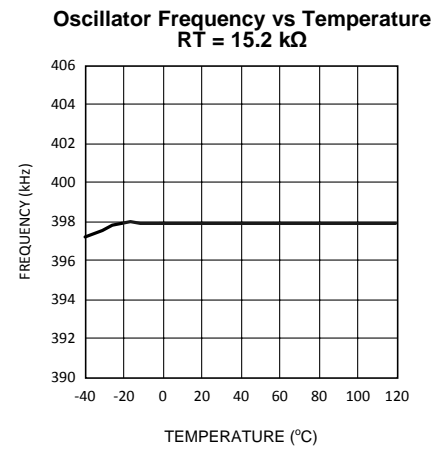

Figure 8.

Typical Performance Characteristics (continued)

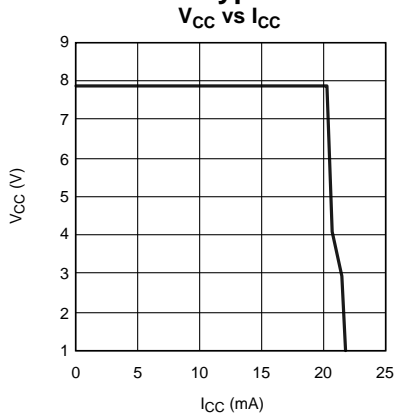

Figure 9.

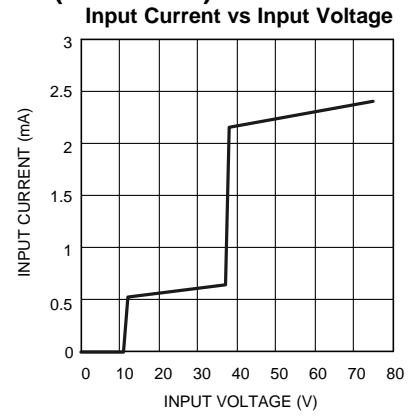

Figure 10.

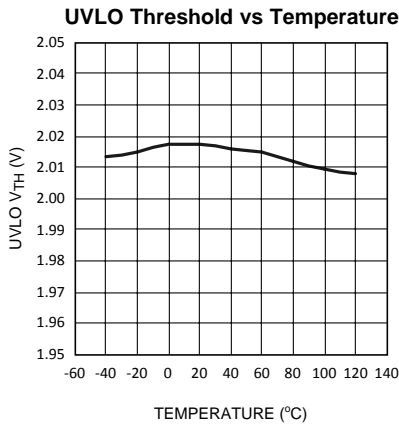

Figure 11.

Specialized Block Diagrams

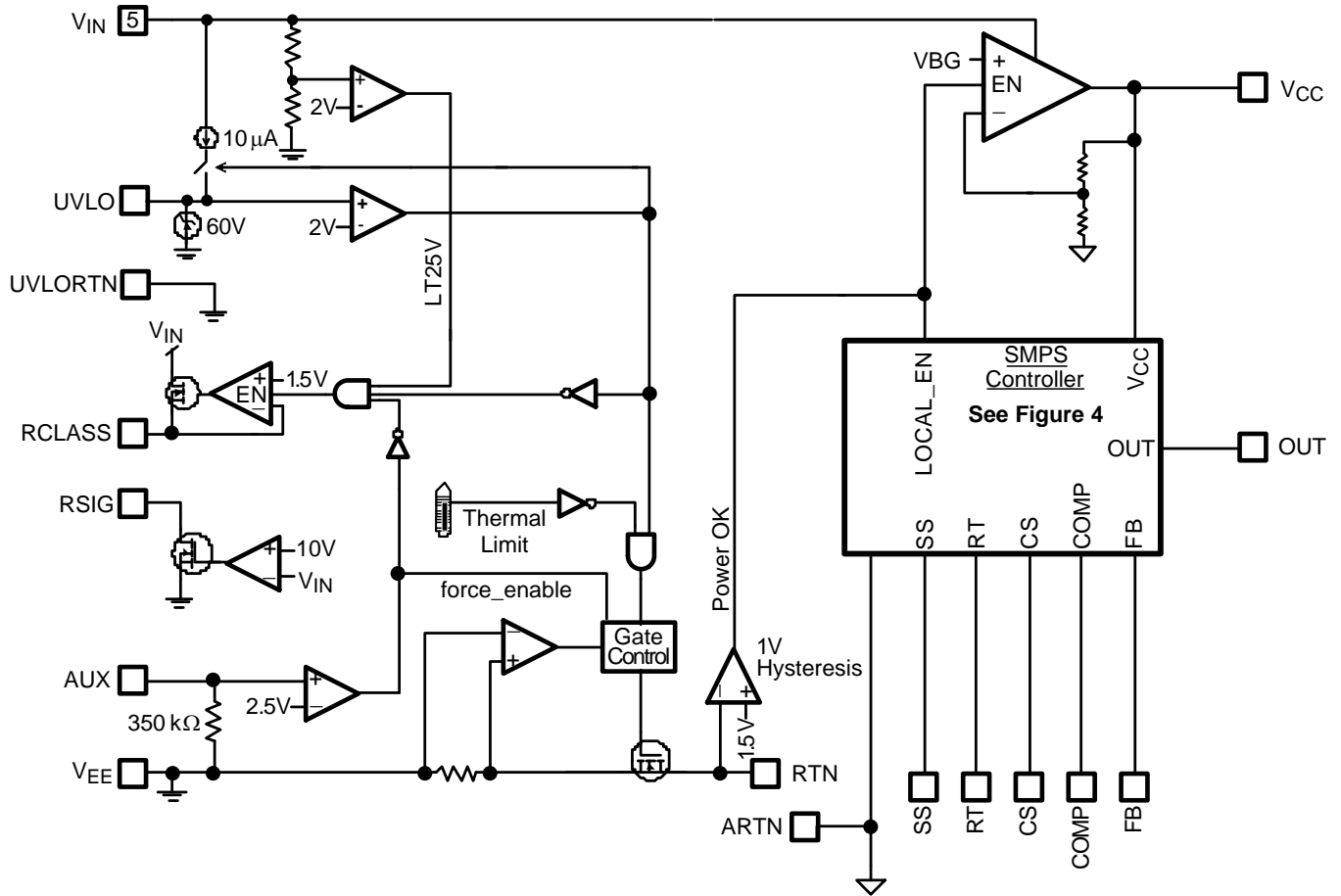

Figure 12. Top Level Block Diagram

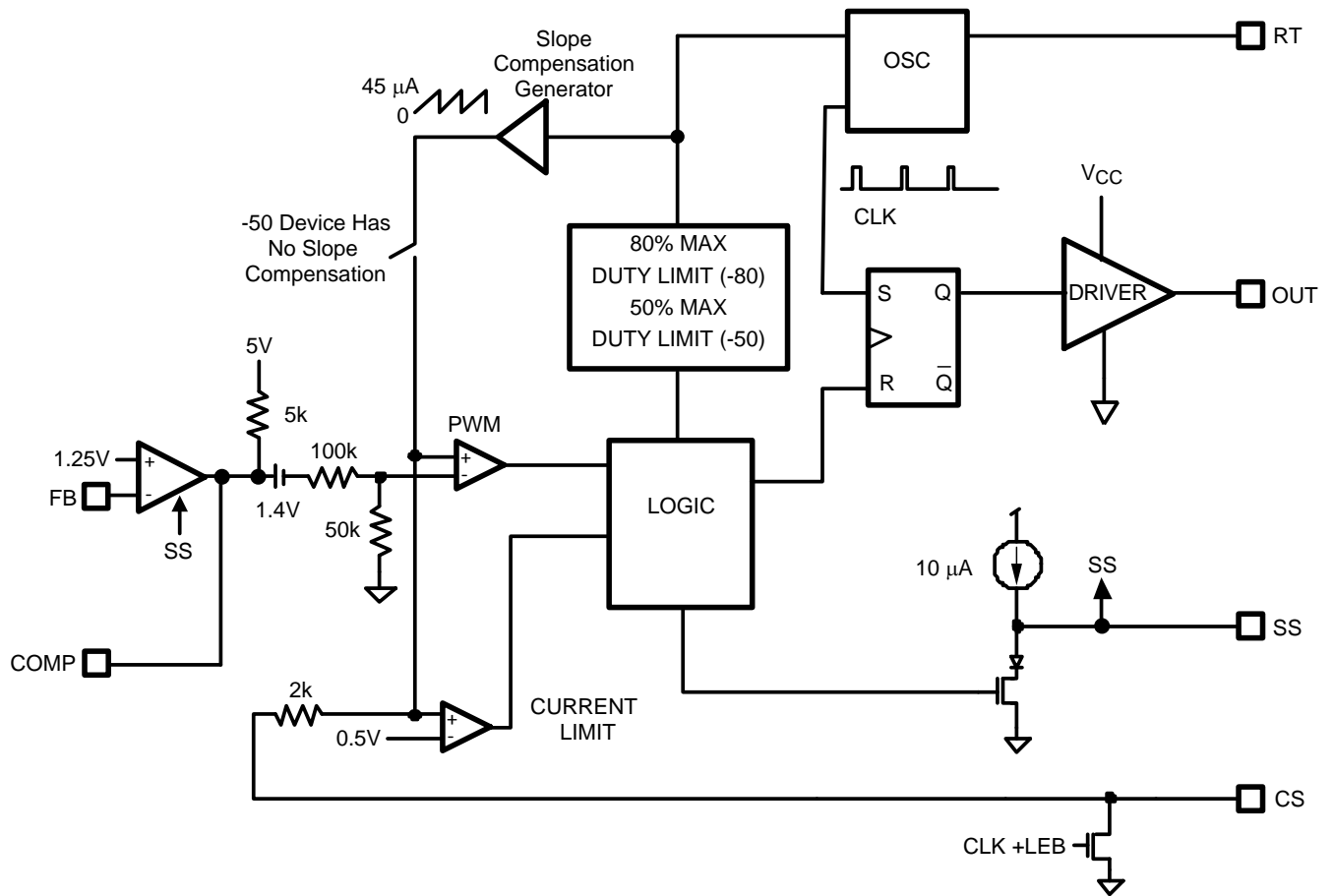

Figure 13. PWM Controller Block Diagram

DETAILED OPERATING DESCRIPTION

The LM5071 power interface port and pulse width modulation (PWM) controller provides a complete integrated solution for Powered Devices (PD) that connect into Power over Ethernet (PoE) systems. Major features of the PD interface portion of the IC include detection, classification, thermal limit, programmable undervoltage lockout, and current limit monitoring. The device also includes a high-voltage start-up bias regulator that operates over a wide input range up to 60V. The switch mode power supply (SMPS) control portion of the IC includes power good sensing, V_{CC} regulator under-voltage lockout, cycle-by-cycle current limit, error amplifier, slope compensation, soft-start, and oscillator sync capability. This high speed BiCMOS IC has total propagation delays less than 100ns and a 1MHz capable oscillator programmed by a single external resistor. The LM5071 PWM controller provides current-mode control for dc-dc converter topologies requiring a single drive output, such as Flyback and Forward topologies. The LM5071 PWM enables all of the advantages of current-mode control including line feed-forward, cycle-by-cycle current limit and simplified loop compensation. The oscillator ramp is internally buffered and added to the PWM comparator input ramp to provide slope compensation necessary for current mode control at duty cycles greater than 50% (-80 suffix only).

Modes of Operation

The LM5071 PD interface is designed to provide a fully compliant IEEE 802.3af system. As such, the modes of operation take into account the barrel rectifiers often utilized to correctly polarize the dc input from the Ethernet cable.

Table 1. Operating Modes With Respect to Input Voltage

Input Voltage V_{IN} wrt V_{EE}	Mode of Operation
1.8V to 10.0V	Detection (Signature)
12.5V to 25.0V	Classification
25.0V to UVLO Rising V_{th}	Awaiting Full Power
60V to UVLO Falling V_{th}	Normal Powered Operation

An external signature resistor is connected to V_{EE} when V_{IN} exceeds 1.8V, initiating detection mode. During detection mode, quiescent current drawn by the LM5071 is less than 10uA. Between 10.0V and 12.5V, the device enters classification mode and the signature resistor is disabled. The nominal range for classification mode is 11.5V to 25.0V. The classification current is turned off once the classification range voltage is exceeded, to reduce power dissipation. Between 25.0V and UVLO release, the device is in a standby state, awaiting the input voltage to reach the operational range to complete the power up sequence. Once the V_{IN} voltage increases above the upper UVLO threshold voltage, the internal power MOSFET is enabled to deliver a constant current to charge the input capacitor of the dc-dc converter. When the MOSFET V_{ds} voltage falls below 1.5V, the internal Power Good signal enables the SMPS controller. The LM5071 is specified to operate with an input voltage as high as 60.0V. The SMPS controller and internal MOSFET are disabled when V_{IN} falls to the lower UVLO threshold.

Detection Signature

To detect a potential powered device candidate, the PSE (Power Sourcing Equipment) will apply a voltage from 2.8V to 10V across the input terminals of the PD. The voltage can be of either polarity so a diode barrel network is required on both lines to ensure this capability. The PSE will take two measurements, separated by at least 1V and 2ms of time. The voltage ramp between measurement points will not exceed 0.1V/us. The delta voltage / delta current calculation is then performed; if the detected impedance is above 23.75k Ω and below 26.25k Ω , the PSE will consider a PD to be present. If the impedance is less than 15k Ω or greater than 33k Ω a PD will be considered not present and will not receive power. Impedances between these values may or may not indicate the presence of a valid PD. The LM5071 will enable the signature resistor at a controller input voltage of 1.5V to take into account the diode voltage drops. An external signature resistor should be placed between the VIN and RSIG pins. The signature resistor is in parallel with the external UVLO resistor divider, and its value should be calculated accordingly. Targeting 24.5k Ω increases margin in the signature design as the input bridge rectifier diodes contribute to the series resistance measured at the PD input terminals. The PSE will tolerate no more than 1.9V of offset voltage (caused by the external diodes) or more than 10uA of offset current (bias current). The input capacitance must be greater than 0.05uF and less than 0.12uF. To increase efficiency, the signature resistor is disabled by the LM5071 controller once the input voltage is above the detection range (> 11V).

Classification

To classify the PD, the PSE will present a voltage between 14.5V and 20.5V to the PD. The LM5071 enables classification mode at a nominal input voltage of 11.5V. An internal 1.5V linear regulator and an external resistor connected to the RCLASS pin provide classification programming current. [Table 1](#) shows the external classification resistor required for a particular class.

The classification current flows through the IC into the classification resistor. The suggested resistor values take into account the bias current flowing into the IC. A different desired RCLASS can be calculated by dividing 1.5V by the desired classification current.

Per the IEEE 802.3af specification, classification is optional, and the PSE will default to class 0 if a valid classification current is not detected. If PD classification is not desired (i.e., Class 0), simply leave the RCLASS pin open. The classification time period may not last longer than 75ms as per IEEE 802.3af. The LM5071 will remain in classification mode until V_{IN} is greater than 25V.

Table 2. Classification Levels and Required External Resistors

Class	P _{MIN}	P _{MAX}	ICLASS (MIN)	ICLASS (MAX)	RCLASS
0	0.44W	12.95W	0mA	4mA	Open
1	0.44W	3.84W	9mA	12mA	150Ω
2	3.84W	6.49W	17mA	20mA	82.5Ω
3	6.49W	12.95W	26mA	30mA	54.9Ω
4	Reserved	Reserved	36mA	44mA	38.3Ω

Undervoltage Lockout (UVLO)

The IEEE 802.3af specification states that the PSE will supply power to the PD within 400ms after completion of detection. The LM5071 contains a programmable line Under Voltage Lock Out (UVLO) circuit. The first resistor should be connected between the V_{IN} to UVLO pins; the bottom resistor in the divider should be connected between the UVLO and UVLORTN pins.

The divider must be designed such that the voltage at the UVLO pin equals 2.0V when V_{IN} reaches the desired minimum operating level. If the UVLO threshold is not met, the interface control and SMPS control will remain in standby.

UVLO hysteresis is accomplished with an internal 10uA current source that is switched on and off into the impedance of the UVLO set point divider. When the UVLO threshold is exceeded, the current source is activated to instantly raise the voltage at the UVLO pin. When the UVLO pin voltage falls below the 2.00V threshold, the current source is turned off, causing the voltage at the UVLO pin to fall. The LM5071 UVLO thresholds cannot be programmed lower than 25V, the AUX pin should be used to force UVLO release below 25V.

There are many additional uses for the UVLO pin. The UVLO function can also be used to implement a remote enable / disable function. Pulling the UVLO pin down below the UVLO threshold disables the interface and SMPS controller unless forced on via AUX pin operation.

AUX Pin Operation

The AUX pin can be used to force operation (UVLO release) of the interface and switching regulator at any input voltage above 9.5V. This is especially useful for auxiliary input (wall transformer) input voltages. The pin has a 2.5V threshold (0.5V hysteresis) and an input impedance of approximately 350kΩ. The input resistor provides a defined pull down impedance if the pin is left open by the user. An external pull down resistor should be used to provide additional noise immunity. The resultant pin voltage from the external resistor divider should be well above the 2.5V threshold to ensure proper auxiliary operation. See [Figure 14](#) for an example of a simple yet robust auxiliary configuration.

Oscillator, Shutdown and Sync Capability

A single external resistor connected between the RT and ARTN pins sets the LM5071 oscillator frequency. Internal to the LM5071–50 device (50% duty cycle limited option) is an oscillator divide by two circuit. This divide by two circuit creates an exact 50% duty cycle clock which is used internally to create a precise 50% duty cycle limit function. Because of this divide by two, the internal oscillator actually operates at twice the frequency of the output (OUT). For the LM5071–80 device the oscillator frequency and the operational output frequency are the same. To set a desired output operational frequency (F), the RT resistor can be calculated from:

LM5071-80:

$$RT = \frac{1}{F \times 165 \times 10^{-12}} \quad (1)$$

LM5071-50:

$$RT = \frac{1}{F \times 330 \times 10^{-12}} \quad (2)$$

The LM5071 can also be synchronized to an external clock. The external clock must have a higher frequency than the free running oscillator frequency set by the RT resistor. The clock signal should be capacitively coupled into the RT pin with a 100pF capacitor. A peak voltage level greater than 3.7 volts at the RT pin is required for detection of the sync pulse. The sync pulse width should be set between 15 to 150ns by the external components. The RT resistor is always required, whether the oscillator is free running or externally synchronized. The voltage at the RT pin is internally regulated to a 2 volts. The RT resistor should be located very close to the device and connected directly to the pins of the controller (RT and ARTN).

PWM Comparator / Slope Compensation

The PWM comparator compares the current ramp signal with the loop error voltage derived from the error amplifier output. The error amplifier output voltage at the COMP pin is offset by 1.4V and then further attenuated by a 3:1 resistor divider. The PWM comparator polarity is such that 0 Volts on the COMP pin will result in zero duty cycle at the controller output. For duty cycles greater than 50 percent, current mode control circuits are subject to sub-harmonic oscillation. By adding an additional fixed slope voltage ramp signal (slope compensation) to the current sense signal, this oscillation can be avoided. The LM5071-80 integrates this slope compensation by summing a current ramp generated by the oscillator with the current sense signal. Additional slope compensation may be added by increasing the source impedance of the current sense signal (with an external resistor between the CS pin and current sense resistor). Since the LM5071-50 is not capable of duty cycles greater than 50%, there is no slope compensation feature in this device.

Soft-Start

The softstart feature allows the power converter to gradually reach the initial steady state operating point, thereby reducing start-up stresses, output overshoot and current surges. At power on, after the V_{CC} undervoltage lockout threshold is satisfied, an internal 10 μ A current source charges an external capacitor connected to the SS pin. The capacitor voltage will ramp up slowly and will limit the COMP pin voltage and the duty cycle of the output pulses.

Gate Driver and Maximum Duty Cycle Limit

The LM5071 provides an internal gate driver (OUT), which can source and sink a peak current of 800mA. The LM5071 is available in two duty cycle limit options. The maximum output duty cycle is typically 80% for the LM5071-80 option and precisely equal to 50% for the LM5071-50 option. The maximum duty cycle function for the LM5071-50 is accomplished with an internal toggle flip-flop which ensures an accurate duty cycle limit. The internal oscillator frequency of the LM5071-50 is therefore twice the operating frequency of the PWM controller (OUT pin).

The 80% maximum duty cycle limit of the LM5071-80 is determined by the internal oscillator and varies more than the 50% limit of the LM5071-50. For the LM5071-80, the internal oscillator frequency and the operational frequency of the PWM controller are equal.

Thermal Protection

Internal thermal shutdown circuitry is provided to protect the integrated circuit in the event the maximum junction temperature is exceeded. This feature prevents catastrophic failures from accidental device overheating. When activated, typically at 165 degrees Celsius, the controller is forced into a low power standby state, disabling the output driver, bias regulator, main interface pass MOSFET, and classification regulator if enabled. After the temperature is reduced (typical hysteresis = 25°C) the V_{CC} regulator will be enabled and a softstart sequence initiated.

Thermal shutdown is not enabled during auxiliary power operation as the power MOSFET is not running any current and should not experience an over-temperature condition. If the drain of the MOSFET exceeds 2.5V with respect to VEE (internal Power Good de-assertion), PoE UVLO becomes de-asserted (insertion of PoE or other 48V supply), or the auxiliary power is removed, thermal limit will be re-enabled immediately.

LM5071 Application Circuit Diagrams

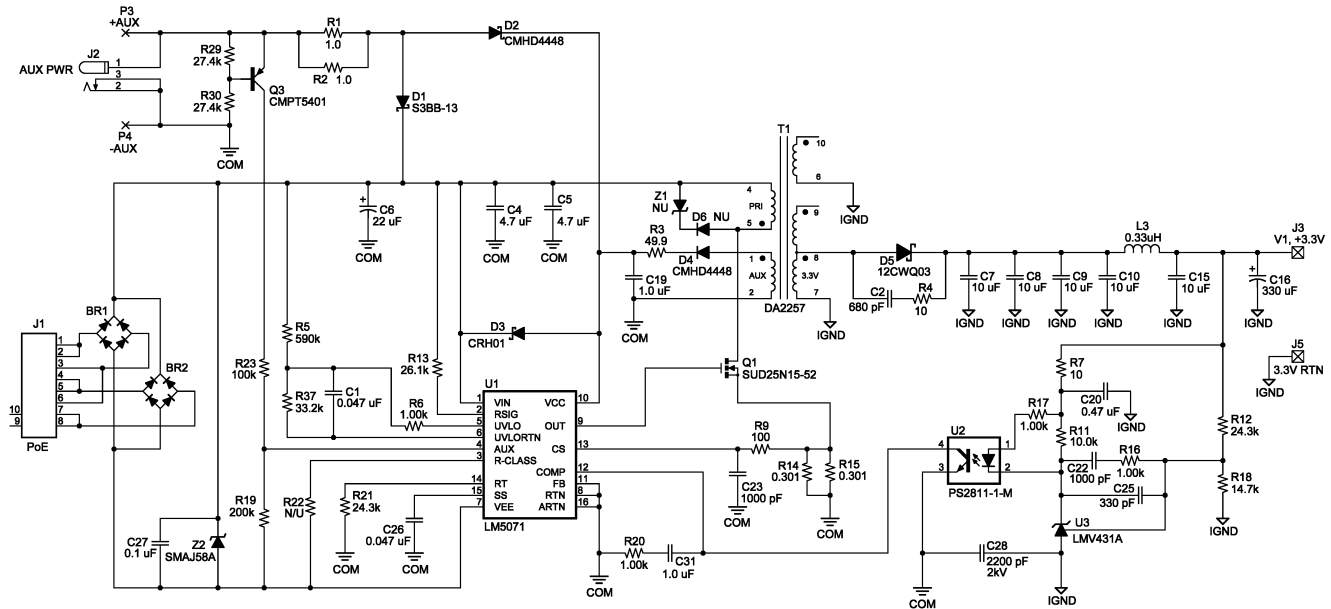

Figure 16. Single Isolated Output with Diode Rectification and 12V Auxiliary Supply

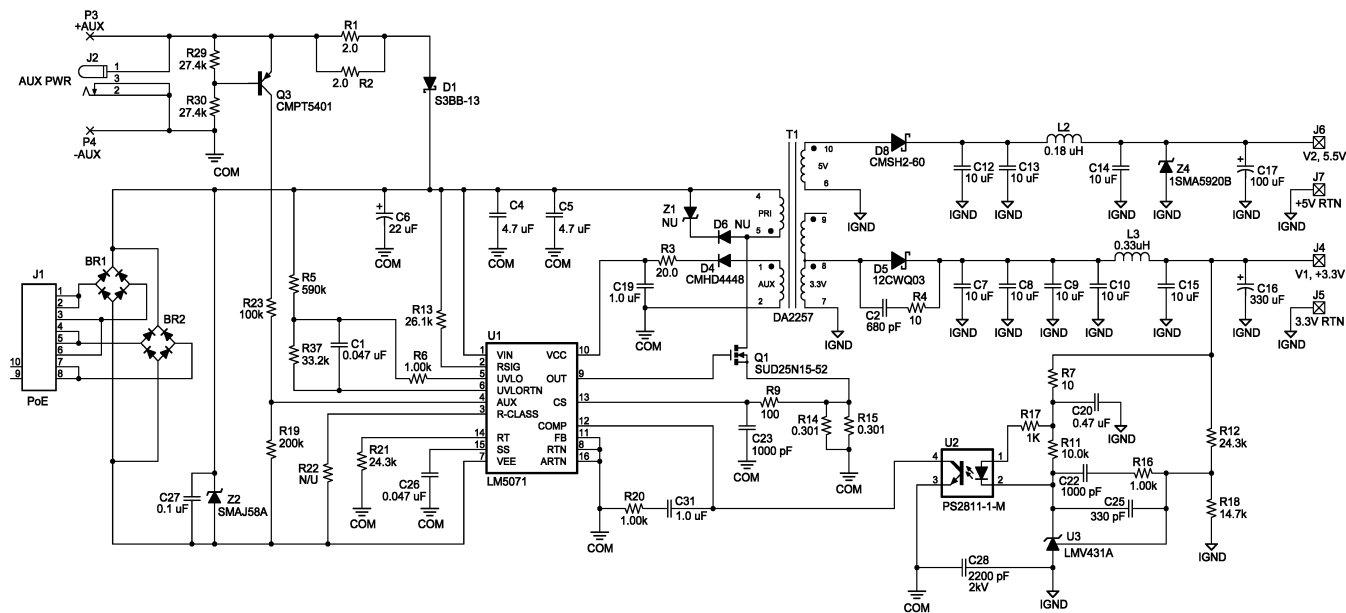

Figure 17. Dual Isolated Output with Diode Rectification

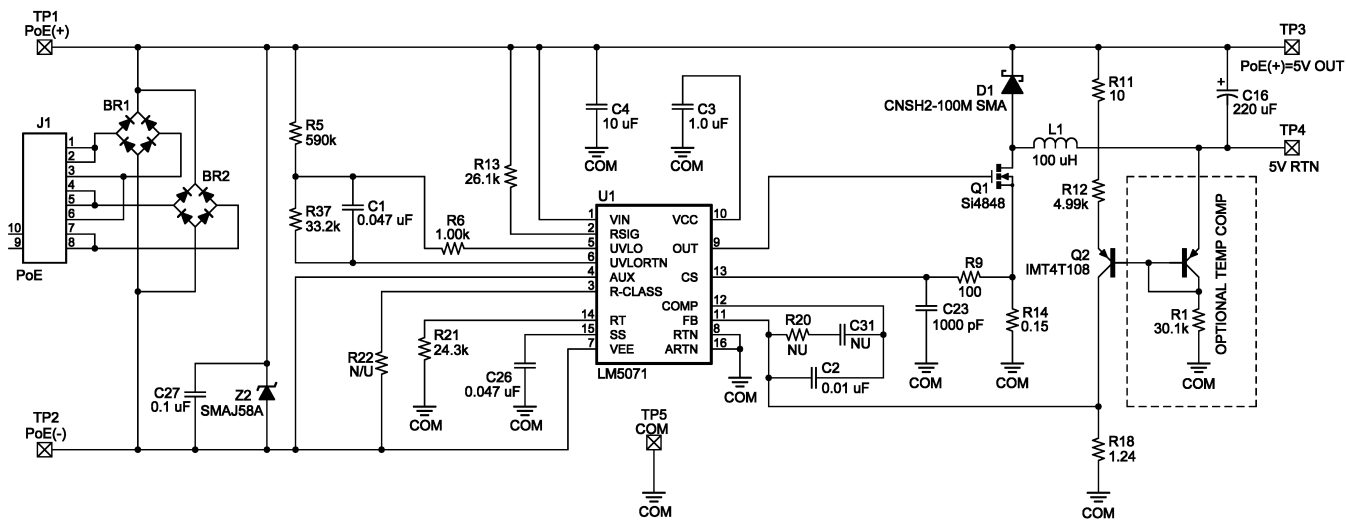

Figure 18. Non-Isolated Output Buck with Diode Rectification

REVISION HISTORY

Changes from Revision D (April 2013) to Revision E	Page
• Changed layout of National Data Sheet to TI format	17

PACKAGING INFORMATION

Orderable Device	Status (1)	Package Type	Package Drawing	Pins	Package Qty	Eco Plan (2)	Lead/Ball Finish (6)	MSL Peak Temp (3)	Op Temp (°C)	Device Marking (4/5)	Samples
LM5071MT-50/NOPB	ACTIVE	TSSOP	PW	16	92	Green (RoHS & no Sb/Br)	CU NIPDAU CU SN	Level-1-260C-UNLIM	-40 to 125	5071MT -50	Samples
LM5071MT-80/NOPB	ACTIVE	TSSOP	PW	16	92	Green (RoHS & no Sb/Br)	CU NIPDAU CU SN	Level-1-260C-UNLIM	-40 to 125	5071MT -80	Samples
LM5071MTX-50/NOPB	ACTIVE	TSSOP	PW	16	2500	Green (RoHS & no Sb/Br)	CU NIPDAU CU SN	Level-1-260C-UNLIM	-40 to 125	5071MT -50	Samples
LM5071MTX-80/NOPB	ACTIVE	TSSOP	PW	16	2500	Green (RoHS & no Sb/Br)	CU NIPDAU CU SN	Level-1-260C-UNLIM	-40 to 125	5071MT -80	Samples

(1) The marketing status values are defined as follows:

ACTIVE: Product device recommended for new designs.

LIFEBUY: TI has announced that the device will be discontinued, and a lifetime-buy period is in effect.

NRND: Not recommended for new designs. Device is in production to support existing customers, but TI does not recommend using this part in a new design.

PREVIEW: Device has been announced but is not in production. Samples may or may not be available.

OBSELETE: TI has discontinued the production of the device.

(2) Eco Plan - The planned eco-friendly classification: Pb-Free (RoHS), Pb-Free (RoHS Exempt), or Green (RoHS & no Sb/Br) - please check <http://www.ti.com/productcontent> for the latest availability information and additional product content details.

TBD: The Pb-Free/Green conversion plan has not been defined.

Pb-Free (RoHS): TI's terms "Lead-Free" or "Pb-Free" mean semiconductor products that are compatible with the current RoHS requirements for all 6 substances, including the requirement that lead not exceed 0.1% by weight in homogeneous materials. Where designed to be soldered at high temperatures, TI Pb-Free products are suitable for use in specified lead-free processes.

Pb-Free (RoHS Exempt): This component has a RoHS exemption for either 1) lead-based flip-chip solder bumps used between the die and package, or 2) lead-based die adhesive used between the die and leadframe. The component is otherwise considered Pb-Free (RoHS compatible) as defined above.

Green (RoHS & no Sb/Br): TI defines "Green" to mean Pb-Free (RoHS compatible), and free of Bromine (Br) and Antimony (Sb) based flame retardants (Br or Sb do not exceed 0.1% by weight in homogeneous material)

(3) MSL, Peak Temp. - The Moisture Sensitivity Level rating according to the JEDEC industry standard classifications, and peak solder temperature.

(4) There may be additional marking, which relates to the logo, the lot trace code information, or the environmental category on the device.

(5) Multiple Device Markings will be inside parentheses. Only one Device Marking contained in parentheses and separated by a "~" will appear on a device. If a line is indented then it is a continuation of the previous line and the two combined represent the entire Device Marking for that device.

(6) Lead/Ball Finish - Orderable Devices may have multiple material finish options. Finish options are separated by a vertical ruled line. Lead/Ball Finish values may wrap to two lines if the finish value exceeds the maximum column width.

Important Information and Disclaimer: The information provided on this page represents TI's knowledge and belief as of the date that it is provided. TI bases its knowledge and belief on information provided by third parties, and makes no representation or warranty as to the accuracy of such information. Efforts are underway to better integrate information from third parties. TI has taken and continues to take reasonable steps to provide representative and accurate information but may not have conducted destructive testing or chemical analysis on incoming materials and chemicals. TI and TI suppliers consider certain information to be proprietary, and thus CAS numbers and other limited information may not be available for release.

In no event shall TI's liability arising out of such information exceed the total purchase price of the TI part(s) at issue in this document sold by TI to Customer on an annual basis.

TAPE AND REEL INFORMATION

QUADRANT ASSIGNMENTS FOR PIN 1 ORIENTATION IN TAPE

*All dimensions are nominal

Device	Package Type	Package Drawing	Pins	SPQ	Reel Diameter (mm)	Reel Width W1 (mm)	A0 (mm)	B0 (mm)	K0 (mm)	P1 (mm)	W (mm)	Pin1 Quadrant
LM5071MTX-50/NOPB	TSSOP	PW	16	2500	330.0	12.4	6.95	5.6	1.6	8.0	12.0	Q1
LM5071MTX-80/NOPB	TSSOP	PW	16	2500	330.0	12.4	6.95	5.6	1.6	8.0	12.0	Q1

TAPE AND REEL BOX DIMENSIONS

*All dimensions are nominal

Device	Package Type	Package Drawing	Pins	SPQ	Length (mm)	Width (mm)	Height (mm)
LM5071MTX-50/NOPB	TSSOP	PW	16	2500	367.0	367.0	35.0
LM5071MTX-80/NOPB	TSSOP	PW	16	2500	367.0	367.0	35.0



NOTES:

1. All linear dimensions are in millimeters. Any dimensions in parenthesis are for reference only. Dimensioning and tolerancing per ASME Y14.5M.
2. This drawing is subject to change without notice.
3. This dimension does not include mold flash, protrusions, or gate burrs. Mold flash, protrusions, or gate burrs shall not exceed 0.15 mm per side.
4. This dimension does not include interlead flash. Interlead flash shall not exceed 0.25 mm per side.
5. Reference JEDEC registration MO-153.

EXAMPLE BOARD LAYOUT

PW0016A

TSSOP - 1.2 mm max height

SMALL OUTLINE PACKAGE



LAND PATTERN EXAMPLE
EXPOSED METAL SHOWN
SCALE: 10X



SOLDER MASK DETAILS

4220204/A 02/2017

NOTES: (continued)

- 6. Publication IPC-7351 may have alternate designs.
- 7. Solder mask tolerances between and around signal pads can vary based on board fabrication site.

EXAMPLE STENCIL DESIGN

PW0016A

TSSOP - 1.2 mm max height

SMALL OUTLINE PACKAGE



SOLDER PASTE EXAMPLE
BASED ON 0.125 mm THICK STENCIL
SCALE: 10X

4220204/A 02/2017

NOTES: (continued)

8. Laser cutting apertures with trapezoidal walls and rounded corners may offer better paste release. IPC-7525 may have alternate design recommendations.
9. Board assembly site may have different recommendations for stencil design.

IMPORTANT NOTICE AND DISCLAIMER

TI PROVIDES TECHNICAL AND RELIABILITY DATA (INCLUDING DATASHEETS), DESIGN RESOURCES (INCLUDING REFERENCE DESIGNS), APPLICATION OR OTHER DESIGN ADVICE, WEB TOOLS, SAFETY INFORMATION, AND OTHER RESOURCES "AS IS" AND WITH ALL FAULTS, AND DISCLAIMS ALL WARRANTIES, EXPRESS AND IMPLIED, INCLUDING WITHOUT LIMITATION ANY IMPLIED WARRANTIES OF MERCHANTABILITY, FITNESS FOR A PARTICULAR PURPOSE OR NON-INFRINGEMENT OF THIRD PARTY INTELLECTUAL PROPERTY RIGHTS.

These resources are intended for skilled developers designing with TI products. You are solely responsible for (1) selecting the appropriate TI products for your application, (2) designing, validating and testing your application, and (3) ensuring your application meets applicable standards, and any other safety, security, or other requirements. These resources are subject to change without notice. TI grants you permission to use these resources only for development of an application that uses the TI products described in the resource. Other reproduction and display of these resources is prohibited. No license is granted to any other TI intellectual property right or to any third party intellectual property right. TI disclaims responsibility for, and you will fully indemnify TI and its representatives against, any claims, damages, costs, losses, and liabilities arising out of your use of these resources.

TI's products are provided subject to TI's Terms of Sale (www.ti.com/legal/termsofsale.html) or other applicable terms available either on ti.com or provided in conjunction with such TI products. TI's provision of these resources does not expand or otherwise alter TI's applicable warranties or warranty disclaimers for TI products.

Mailing Address: Texas Instruments, Post Office Box 655303, Dallas, Texas 75265
Copyright © 2018, Texas Instruments Incorporated

Looking for pricing, stock, or lifecycle information?

Click below to explore more details on WIN SOURCE:

 [View LM5071MT-50 on WIN SOURCE](#)

 [Texas Instruments](#) Information

Optimize Your Supply Chain with WIN SOURCE Solutions

-  Global Sourcing Solution
-  Obsolete Management
-  Cost Control Management
-  Shortage Management
-  Alternative Solution
-  Excess Inventory Management