



**THE DATASHEET OF  
LM5070MTCX-50/NOPB**



# LM5070 Integrated Power Over Ethernet PD Interface and PWM Controller

 Check for Samples: [LM5070](#)

## FEATURES

- Fully Compliant 802.3af Power Interface Port
- 80V, 1Ω, 400 mA Internal MOSFET
- Programmable Inrush Current Limit
- Detection Resistor Disconnect Function
- Programmable Classification Current
- Programmable Under-voltage Lockout with Programmable Hysteresis
- Thermal Shutdown Protection
- Current Mode Pulse Width Modulator
- Supports Both Isolated and Non-Isolated Applications
- Error Amplifier and Reference for Non-Isolated Applications
- Programmable Oscillator Frequency
- Programmable Soft-Start
- 80% Maximum Duty Cycle Limiter, Slope Compensation (-80 device)
- 50% Maximum Duty Cycle Limiter, No Slope Compensation (-50 device)
- 800 mA Peak Gate Driver

## DESCRIPTION

The LM5070 power interface port and pulse width modulation (PWM) controller provides a complete integrated solution for Powered Devices (PD) that connect into Power over Ethernet (PoE) systems. The LM5070 integrates an 80V, 400mA line connection switch and associated control for a fully IEEE 802.3af compliant interface with a full featured current mode pulse width modulator dc-dc converter. All power sequencing requirements between the controller interface and switch mode power supply (SMPS) are integrated into the IC. Two options are available providing either an 80% maximum duty cycle limit with slope compensation (on the -80 suffix) device or a 50% maximum duty cycle limit and no slope compensation on the (-50 suffix) device.

## PACKAGES

- TSSOP-16
- WSON-16 (5 mm x 5 mm)

## Block Diagrams

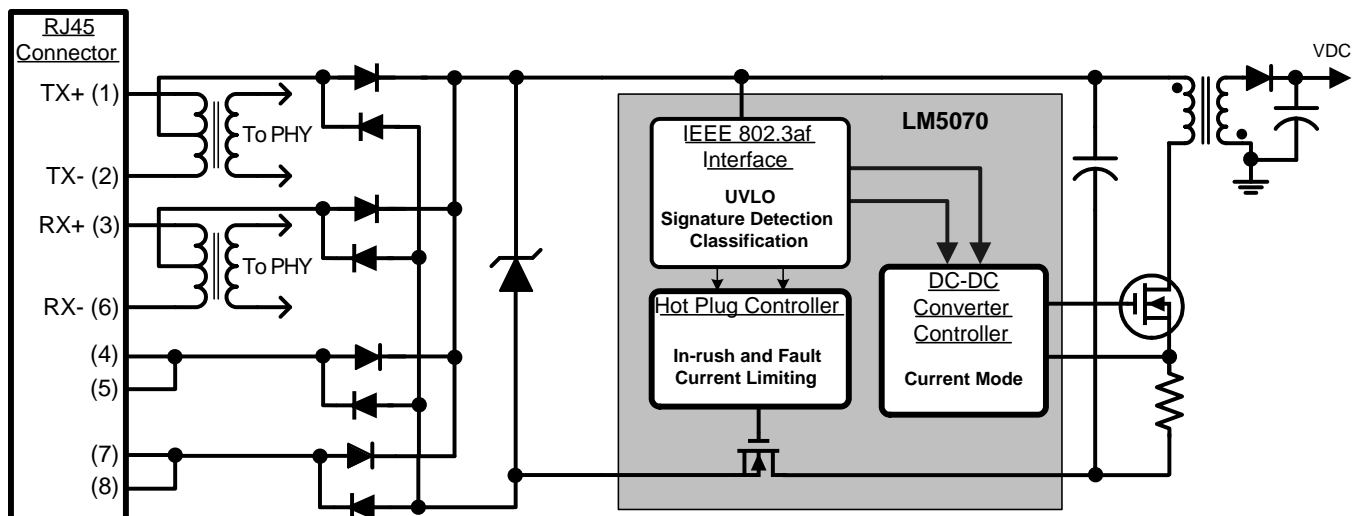

Please be aware that an important notice concerning availability, standard warranty, and use in critical applications of Texas Instruments semiconductor products and disclaimers thereto appears at the end of this data sheet.

All trademarks are the property of their respective owners.

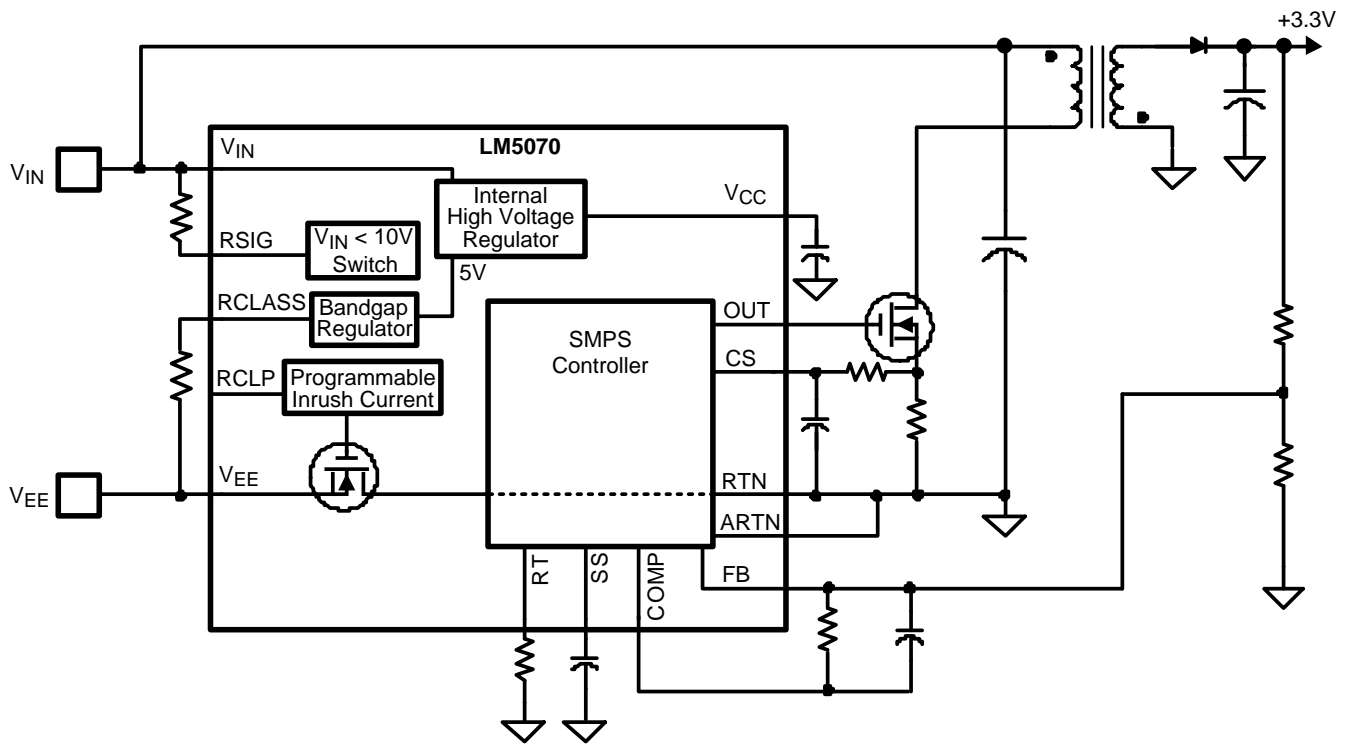

Figure 1. Simplified Block Diagram and Application

Connection Diagram

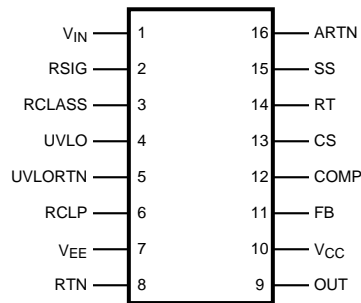

Figure 2. 16 Lead TSSOP/WSON  
See Package Number PW or NHQ0016A

**PIN DESCRIPTIONS**

Pin	Name	Description	Application Information
1	V <sub>IN</sub>	System high potential input.	The diode "OR" of several lines entering the PD, it is the more positive input potential.
2	RSIG	Signature resistor pin.	Connect a 25kΩ signature resistor from V <sub>IN</sub> to this pin for signature detection.
3	RCLASS	Classification resistor pin.	Connect the classification programming resistor from this pin to V <sub>EE</sub> .
4	UVLO	Line under-voltage lockout.	An external resistor divider from V <sub>IN</sub> to UVLORTN programs the shutdown levels with a 2.00V threshold at the UVLO pin. Hysteresis is set by a switched internal 10uA current source that forces additional current into the resistor divider.
5	UVLORTN	Return for the external UVLO resistors.	Connect the bottom resistor of the resistor divider between the UVLO pin and this pin.
6	RCLP	Current limit programming pin.	Programs the inrush current limit for the device. If left open, the inrush current limit will default to 400mA max.
7	V <sub>EE</sub>	System low potential input.	Diode "OR'd" to the RJ45 connector and PSE's -48V supply, it is the more negative input potential.
8	RTN	System return for the PWM converter.	The drain of the internal current limiting power MOSFET which connects V <sub>EE</sub> to the return path of the dc-dc converter.
9	OUT	Output of the PWM controller.	DC-DC converter gate driver output with 800mA peak sink current capability.
10	V <sub>CC</sub>	Output of the internal high voltage series pass regulator. Regulated output voltage is nominally 7.8V.	When the auxiliary transformer winding (if used) raises the voltage on this pin above the regulation set point, the internal series pass regulator will shutdown, reducing the controller power dissipation.
11	FB	Feedback signal.	Inverting input of the internal error amplifier. The non-inverting input is internally connected to a 1.25V reference.
12	COMP	The output of the error amplifier and input to the Pulse Width Modulator.	COMP pull-up is provided by an internal 5K resistor which may be used to bias an opto-coupler transistor.
13	CS	Current sense input.	Current sense input for current mode control and over-current protection. Current limiting is accomplished using a dedicated current sense comparator. If the CS pin voltage exceeds 0.5V the OUT pin switches low for cycle-by-cycle current limiting. CS is held low for 50ns after OUT switches high to blank leading edge current spikes.
14	RT / SYNC	Oscillator timing resistor pin and synchronization input.	An external resistor connected from RT to ARTN sets the oscillator frequency. This pin will also accept narrow ac-coupled synchronization pulses from an external clock.
15	SS	Soft-start input.	An external capacitor and an internal 10uA current source set the soft-start ramp rate.
16	ARTN	Analog PWM supply return.	RTN for sensitive analog circuitry including the SMPS current limit amplifier.
—	EP	Exposed PAD, underside of the WSON package option.	Internally bonded to the die substrate. Connect to V <sub>EE</sub> potential for low thermal impedance.



These devices have limited built-in ESD protection. The leads should be shorted together or the device placed in conductive foam during storage or handling to prevent electrostatic damage to the MOS gates.

### Absolute Maximum Ratings<sup>(1)(2)</sup>

$V_{IN}$ , RTN to $V_{EE}$		-0.3V to 80V
RSIG to $V_{IN}$		-12V to 0V
UVLO to $V_{EE}$		-0.3V to 57V
UVLORTN		-0.3V to 13V
RCLASS, RCLP to $V_{EE}$		-0.3V to 7V
ARTN to RTN		-0.3V to 0.3V
$V_{CC}$ , OUT to ARTN		-0.3V to 16V
All other inputs to ARTN		-0.3V to 7V
ESD Rating	Human Body Model	2000V
Storage Temperature		-65°C to +150°C
Junction Temperature		150°C
Lead Temperature <sup>(3)</sup>	Wave (4 seconds)	260°C
	Infrared (10 seconds)	240°C
	Vapor Phase (75 seconds)	219°C

- (1) Absolute Maximum Ratings are limits beyond which damage to the device may occur. Operating Ratings are conditions under which operation of the device is intended to be functional. For specifications and test conditions, see the Electrical Characteristics. The absolute maximum rating of  $V_{IN}$ , RTN to  $V_{EE}$  is derated to (-0.3V to 76V) at -40°C.
- (2) If Military/Aerospace specified devices are required, please contact the Texas Instruments Sales Office/Distributors for availability and specifications.
- (3) For detailed information on soldering plastic TSSOP and WSON packages, see the Packaging Databook available from TI.

### Operating Ratings

$V_{IN}$ voltage	1.8V to 75V
External voltage applied to $V_{CC}$	8.1V to 15V
Operating Junction Temperature	-40°C to +125°C

### Electrical Characteristics<sup>(1)</sup>

Specifications in standard type face are for  $T_J = +25^\circ\text{C}$  and those in **boldface type** apply over the full operating junction temperature range. Unless otherwise specified:  $V_{IN} = 48\text{V}$ ,  $V_{CC} = 10\text{V}$ , RT = 30.3k $\Omega$ .

Symbol	Parameter	Conditions	Min	Typ	Max	Units
<b>Powered Interface</b>						
IOS	Offset Current	$V_{IN} < 10.0\text{V}$			<b>10</b>	$\mu\text{A}$
VCLSS(ON)	Signature Resistor Disable / Classification Current Turn On	$V_{IN}$ with respect to $V_{EE}$	<b>10.0</b>	11.5	<b>12.5</b>	V
VCLSS(OFF)	Classification Current Turn Off	$V_{IN}$ with respect to $V_{EE}$	<b>20.5</b>	22.0	<b>23.0</b>	V
	Classification Voltage	With respect to $V_{EE}$	<b>1.43</b>	1.5	<b>1.57</b>	V
ICLASS	Supply Current During Classification	$V_{IN} = 17\text{V}$		0.5	<b>1.0</b>	mA
IDC	Supply Current During Normal Operation	OUT floating		1	<b>1.9</b>	mA
	UVLO Pin Reference Voltage	$V_{IN} > 12\text{V}$	<b>1.95</b>	2.00	<b>2.05</b>	V
	UVLO Hysteresis Current	$V_{IN} > \text{UVLO}$	<b>8.0</b>	10	<b>11.5</b>	$\mu\text{A}$
	Softstart Release	RTN falling with respect to $V_{EE}$	<b>1.2</b>	1.45	<b>1.7</b>	V
	Softstart Release Hysteresis	RTN rising with respect to $V_{EE}$	<b>0.8</b>	1.1	<b>1.3</b>	V
RDS(ON)	PowerFET Resistance	$I = 350\text{mA}$ , $V_{IN} = 48\text{V}$		1	<b>2.2</b>	$\Omega$
ILEAK	SMPS Bias Current	$V_{EE} = 0\text{V}$ , $V_{IN} = \text{RTN} = 57\text{V}$			<b>100</b>	$\mu\text{A}$
ILIM	Default Current Limit	$V_{EE} = 0\text{V}$ , RTN = 3.0V, Temp = 0°C to 85°C	<b>350</b>	390	<b>420</b>	mA

- (1) Min and Max limits are 100% production tested at 25 °C. Limits over the operating temperature range are specified through correlation using Statistical Quality Control (SQC) methods. Limits are used to calculate Average Outgoing Quality Level (AOQL).

**Electrical Characteristics<sup>(1)</sup> (continued)**

Specifications in standard type face are for  $T_J = +25^\circ\text{C}$  and those in **boldface type** apply over the full operating junction temperature range. Unless otherwise specified:  $V_{IN} = 48\text{V}$ ,  $V_{CC} = 10\text{V}$ ,  $RT = 30.3\text{k}\Omega$ .

Symbol	Parameter	Conditions	Min	Typ	Max	Units
ILIM	Default Current Limit	$V_{EE} = 0\text{V}$ , $RTN = 3.0\text{V}$ , Temp = $-40^\circ\text{C}$ to $125^\circ\text{C}$	<b>325</b>	390	<b>420</b>	mA
	Current Limit Programming Accuracy	$V_{EE} = 0\text{V}$ , $RTN = 3.0\text{V}$ , $RCLP = 80.6\text{k}\Omega$	<b>-20</b>		<b>+20</b>	%
<b>Startup Regulator</b>						
VccReg	$V_{CC}$ Regulation	Open ckt	<b>7.5</b>	7.8	<b>8.1</b>	V
	$V_{CC}$ Current Limit	See <sup>(2)</sup>	<b>15</b>	20		mA
<b><math>V_{CC}</math> Supply</b>						
	$V_{CC}$ UVLO (Rising)		<b>VccReg – 300mV</b>	VccReg – 100mV		
	$V_{CC}$ UVLO (Falling)		<b>5.9</b>	6.25	<b>6.6</b>	V
	Supply Current ( $I_{CC}$ )	$C_{load} = 0$		1.5	<b>3</b>	mA
<b>Error Amplifier</b>						
GBW	Gain Bandwidth			4		MHz
	DC Gain			75		dB
	Input Voltage	FB = COMP	1.219 <b>1.212</b>		1.281 <b>1.288</b>	V
	COMP Sink Capability	FB=1.5V COMP=1V	<b>5</b>	20		mA
<b>Current Limit</b>						
	ILIM Delay to Output	CS step from 0 to 0.6V, time to onset of OUT transition (90%)		20		ns
	Cycle by Cycle Current Limit Threshold Voltage		<b>0.44</b>	0.5	<b>0.56</b>	V
	Leading Edge Blanking Time			55		ns
	CS Sink Impedance (clocked)			25	<b>55</b>	$\Omega$
<b>Softstart</b>						
	Softstart Current Source		<b>7</b>	10	<b>13</b>	$\mu\text{A}$
<b>Oscillator<sup>(3)</sup></b>						
	Frequency1 (RT = 30.3K)		<b>175</b>	200	<b>225</b>	KHz
	Frequency2 (RT = 10.5K)		<b>505</b>	580	<b>665</b>	KHz
	Sync threshold			3.1	<b>3.8</b>	V
<b>PWM Comparator</b>						
	Delay to Output	COMP set to 2V CS stepped 0 to 0.4V, time to onset of OUT transition low		25		ns
	Min Duty Cycle	COMP=0V			<b>0</b>	%
	Max Duty Cycle (-80 Device)			80		%
	Max Duty Cycle (-50 Device)			50		%
	COMP to PWM Comparator Gain			0.33		
	COMP Open Circuit Voltage		<b>4.5</b>	5.4	<b>6.3</b>	V
	COMP Short Circuit Current	COMP= 0V	<b>0.6</b>	1.1	<b>1.5</b>	mA
<b>Slope Compensation</b>						
	Slope Comp Amplitude (LM5070-80 Device Only)	Delta increase at PWM Comparator to CS		105		mV

(2) Device thermal limitations may limit usable range.

(3) Specification applies to the oscillator frequency. The operational frequency of the LM5070-50 devices is divided by two.

### Electrical Characteristics<sup>(1)</sup> (continued)

Specifications in standard type face are for  $T_J = +25^\circ\text{C}$  and those in **boldface type** apply over the full operating junction temperature range. Unless otherwise specified:  $V_{IN} = 48\text{V}$ ,  $V_{CC} = 10\text{V}$ ,  $R_T = 30.3\text{k}\Omega$ .

Symbol	Parameter	Conditions	Min	Typ	Max	Units
<b>Output Section</b>						
	Output High Saturation	$I_{out} = 50\text{mA}$ , $V_{CC} - V_{OUT}$		0.25	<b>0.75</b>	V
	Output Low Saturation	$I_{out} = 100\text{mA}$		0.25	<b>0.75</b>	V
	Rise time	$C_{load} = 1\text{nF}$		15		ns
	Fall time	$C_{load} = 1\text{nF}$		15		ns
<b>Thermal Shutdown</b>						
Tsd	Thermal Shutdown Temp.			165		$^\circ\text{C}$
Thermal Shutdown Hysteresis				25		$^\circ\text{C}$
<b>Thermal Resistance</b>						
$\theta_{JA}$	Junction to Ambient	PW Package		125		$^\circ\text{C/W}$
		NHQ0016A Package		32		$^\circ\text{C/W}$

### Typical Performance Characteristics

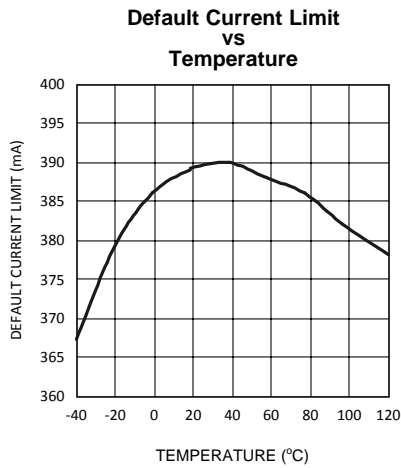

Figure 3.

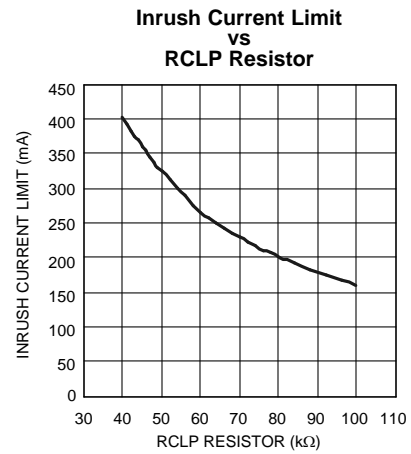

Figure 4.

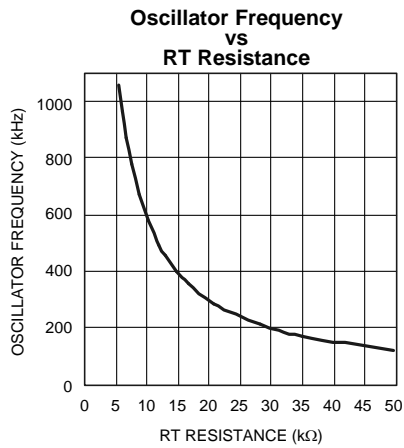

Figure 5.

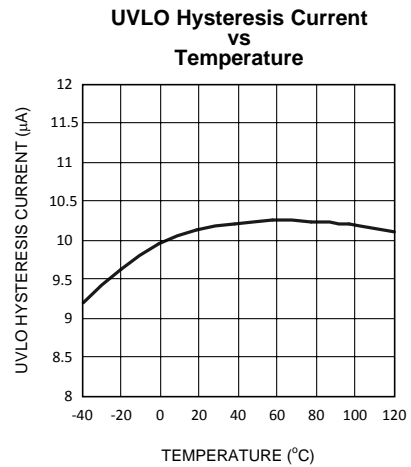

Figure 6.

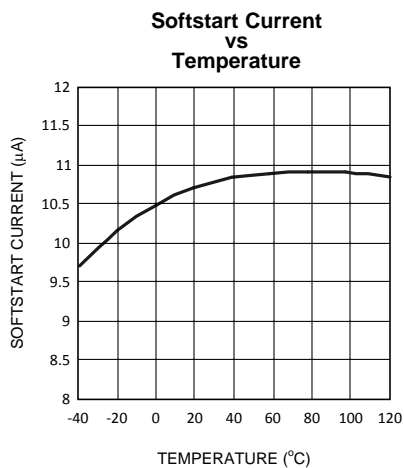

Figure 7.

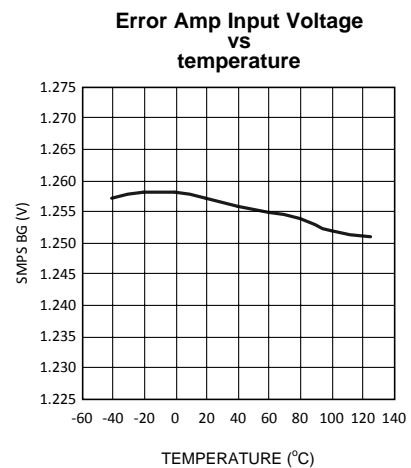
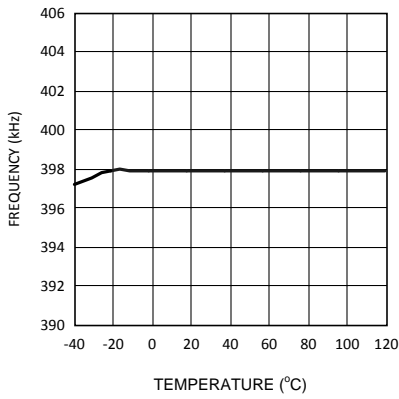

Figure 8.

**Typical Performance Characteristics (continued)**

**Oscillator Frequency vs Temperature**  
RT = 15.2 kΩ



**Figure 9.**

**V<sub>CC</sub> vs I<sub>CC</sub>**

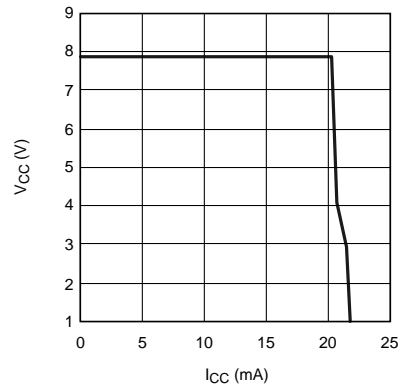

**Figure 10.**

**Input Current vs Input Voltage**

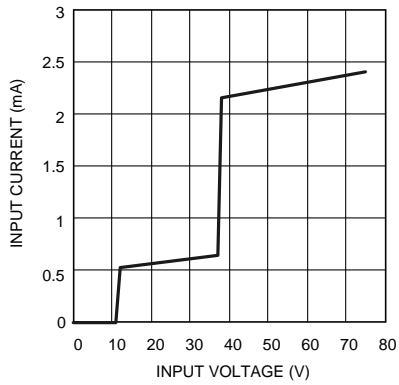

**Figure 11.**

**UVLO V<sub>TH</sub> vs Temperature**

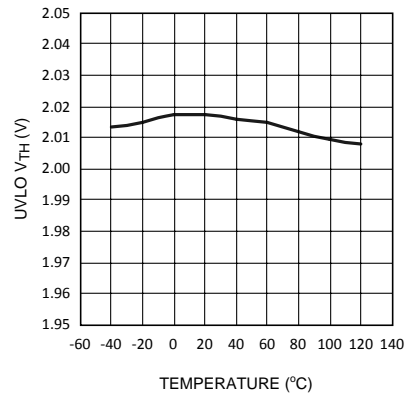

**Figure 12.**

BLOCK DIAGRAMS

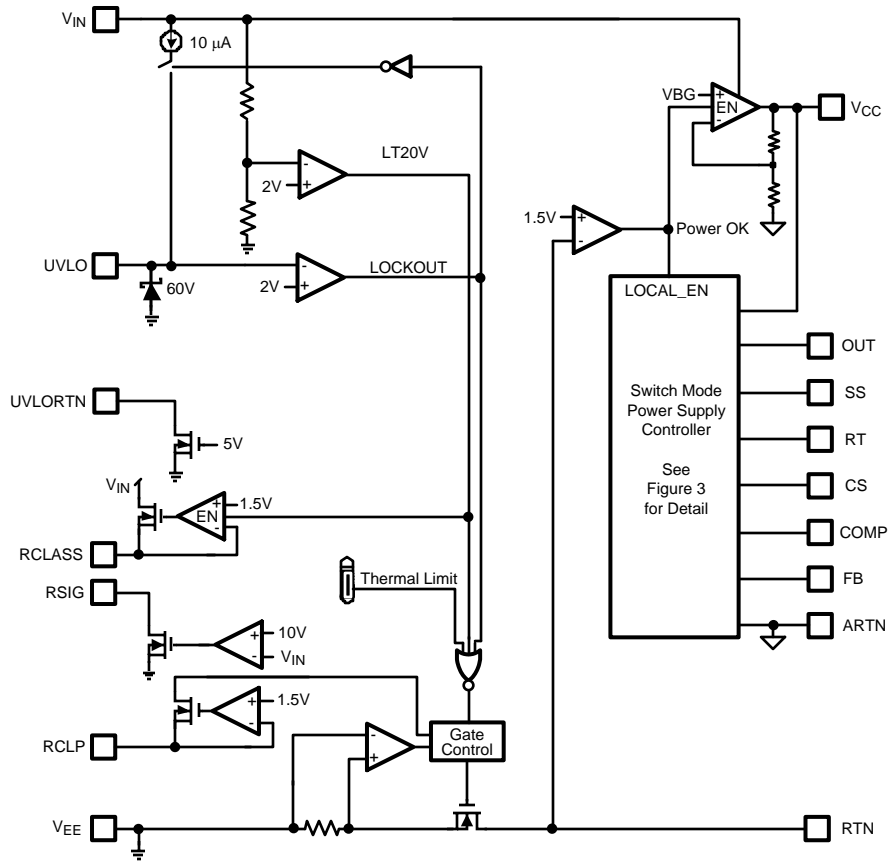

Figure 13. Top Level Block Diagram

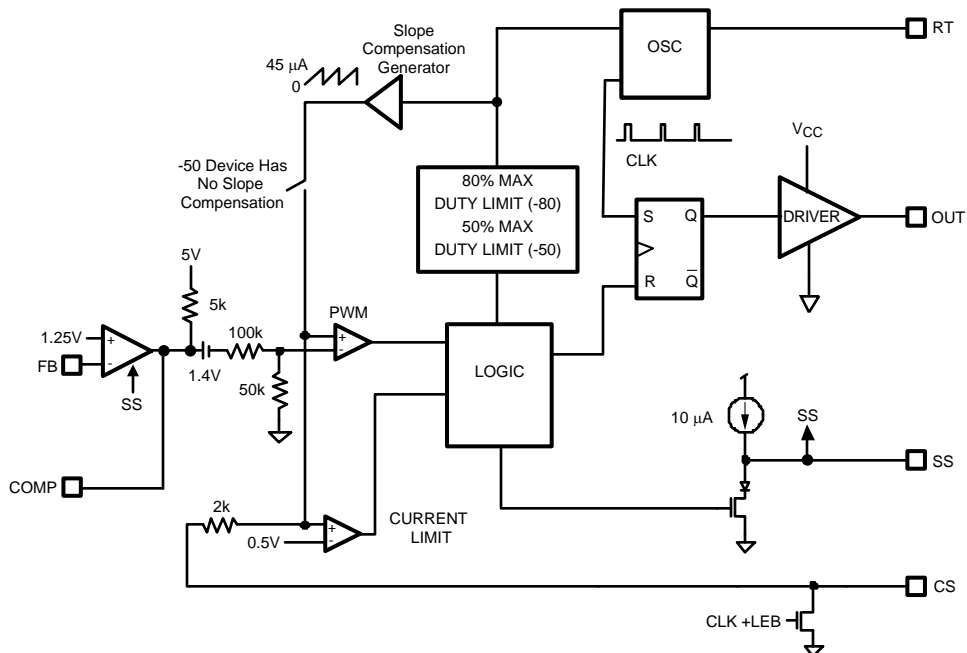

Figure 14. PWM Controller Block Diagram

## Detailed Operating Description

The LM5070 power interface port and pulse width modulation (PWM) controller provides a complete integrated solution for Powered Devices (PD) that connect into Power over Ethernet (PoE) systems. Major features of the PD interface portion of the IC include detection, classification, programmable inrush current limit, thermal limit, programmable undervoltage lockout, and current limit monitoring. The device also includes a high-voltage start-up bias regulator that operates over a wide input range up to 75V. The switch mode power supply (SMPS) control portion of the IC includes power good sensing,  $V_{CC}$  regulator under-voltage lockout, cycle-by-cycle current limit, error amplifier, slope compensation, softstart, and oscillator sync capability. This high speed BiCMOS IC has total propagation delays less than 100ns and a 1MHz capable oscillator programmed by a single external resistor. The LM5070 PWM controller provides current-mode control for dc-dc converter topologies requiring a single drive output, such as Flyback and Forward topologies. The LM5070 PWM enables all of the advantages of current-mode control including line feed-forward, cycle-by-cycle current limit and simplified loop compensation. The oscillator ramp is internally buffered and added to the PWM comparator input ramp to provide slope compensation necessary for current mode control at duty cycles greater than 50% (-80 suffix only).

## Modes of Operation

The LM5070 PD interface is designed to provide a fully compliant IEEE 802.3af system. As such, the modes of operation take into account the barrel rectifiers often utilized to correctly polarize the dc input from the Ethernet cable. [Table 1](#) shows the LM5070 operating modes and associated input voltage range.

**Table 1. Operating Modes With Respect to Input Voltage**

Input Voltage $V_{IN}$ wrt $V_{EE}$	Mode of Operation
1.8V to 10.0V	Detection (Signature)
12.5V to 20.5V	Classification
23.0V to UVLO Rising $V_{th}$	Awaiting Full Power
75V to UVLO Falling $V_{th}$	Normal Powered Operation

An external signature resistor is connected to  $V_{EE}$  when  $V_{IN}$  exceeds 1.8V, initiating detection mode. During detection mode, quiescent current drawn by the LM5070 is less than 10uA. Between 10.0V and 12.5V, the device enters classification mode and the signature resistor is disabled. The nominal range for classification mode is 11.5V to 21.5V. The classification current is turned off once the classification range voltage is exceeded, to reduce power dissipation. Between 21.5V and UVLO release, the device is in a standby state, awaiting the input voltage to reach the operational range to complete the power up sequence. Once the  $V_{IN}$  voltage increases above the upper UVLO threshold voltage, the internal power MOSFET is enabled to deliver a constant current to charge the input capacitor of the dc-dc converter. When the MOSFET  $V_{ds}$  voltage falls below 1.5V, the internal Power Good signal enables the SMPS controller. The LM5070 is specified to operate with an input voltage as high as 75V. The SMPS controller and internal MOSFET are disabled when  $V_{IN}$  falls to the lower UVLO threshold.

## Detection Signature

To detect a potential powered device candidate, the PSE will apply a voltage from 2.8V to 10V across the input terminals of the PD. The voltage can be of either polarity so a diode barrel network is required on both lines to ensure this capability. The PSE will take two measurements, separated by at least 1V and 2ms of time. The voltage ramp between measurement points will not exceed 0.1V/us. The delta voltage / delta current calculation is then performed; if the detected impedance is above 23.75k $\Omega$  and below 26.25k $\Omega$ , the PSE will consider a PD to be present. If the impedance is less than 15k $\Omega$  or greater than 33k $\Omega$  a PD will be considered not present and will not receive power. Impedances between these values may or may not indicate the presence of a valid PD. The LM5070 will enable the signature resistor at a controller input voltage of 1.5V to take into account the diode voltage drops. The PSE will tolerate no more than 1.9V of offset voltage (caused by the external diodes) or more than 10uA of offset current (bias current). The input capacitance must be greater than 0.05uF and less than 0.12uF. To increase efficiency, the signature resistor is disabled by the LM5070 controller once the input voltage is above the detection range (> 11V).

## Classification

To classify the PD, the PSE will present a voltage between 14.5V and 20.5V to the PD. The LM5070 enables classification mode at a nominal input voltage of 11.5V. An internal 1.5V linear regulator and an external resistor connected to the RCLASS pin provide classification programming current. [Table 2](#) shows the external classification resistor required for a particular class.

The classification current flows through the IC into the classification resistor. The suggested resistor values take into account the bias current flowing into the IC. A different desired RCLASS can be calculated by dividing 1.5V by the desired classification current.

Per the IEEE 802.3af specification, classification is optional, and the PSE will default to class 0 if a valid classification current is not detected. If PD classification is not desired (i.e., Class 0), simply leave the RCLASS pin open. The classification time period may not last longer than 75ms as per IEEE 802.3af. The LM5070 will remain in classification mode until  $V_{IN}$  is greater than 22V.

**Table 2. Classification Levels and Required External Resistors**

Class	P <sub>MIN</sub>	P <sub>MAX</sub>	ICLASS (MIN)	ICLASS (MAX)	RCLASS
0	0.44W	12.95W	0mA	4mA	Open
1	0.44W	3.84W	9mA	12mA	150Ω
2	3.84W	6.49W	17mA	20mA	82.5Ω
3	6.49W	12.95W	26mA	30mA	53.6Ω
4	Reserved	Reserved	36mA	44mA	38.3Ω

## Undervoltage Lockout (UVLO)

The IEEE 802.3af specification states that the PSE will supply power to the PD within 400ms after completion of detection. The LM5070 contains a programmable line Under Voltage Lock Out (UVLO) circuit. The first resistor should be connected between the  $V_{IN}$  to UVLO pins; the bottom resistor in the divider should be connected between the UVLO and UVLORTN pins. The bottom resistor should not be tied to  $V_{EE}$  because any current from  $V_{IN}$  to  $V_{EE}$  will cause the system to violate the 10uA maximum offset current specification during detection mode.

The divider must be designed such that the voltage at the UVLO pin equals 2.0V when  $V_{IN}$  reaches the desired minimum operating level. If the UVLO threshold is not met, the interface control and SMPS control will remain in standby.

UVLO hysteresis is accomplished with an internal 10uA current source that is switched on and off into the impedance of the UVLO set point divider. When the UVLO threshold is exceeded, the current source is activated to instantly raise the voltage at the UVLO pin. When the UVLO pin voltage falls below the 2.00V threshold, the current source is turned off, causing the voltage at the UVLO pin to fall. The LM5070 UVLO thresholds cannot be programmed lower than 23V, otherwise the device would operate in classification mode with both the classification current source and the SMPS enabled. The combined power dissipation of these two functions could exceed the maximum power dissipation of the package.

There are many additional uses for the UVLO pin. The UVLO function can also be used to implement a remote enable / disable function. Pulling the UVLO pin down below the UVLO threshold disables the interface and SMPS controller.

## Power Supply Operation / Current Limit Programming

Once the UVLO threshold has been satisfied, the interface controller of the LM5070 will charge up the SMPS input capacitor through the internal power MOSFET. This load capacitance provides input filtering for the power converter section and must be at least 5uF per the IEEE 802.3af specification. To accomplish the charging in a controlled manner, the power MOSFET is current limited to 375mA. The IEEE 802.3af specification requires that the load capacitance be charged within 75ms.

Some legacy PSEs may not be able to supply the IEEE maximum power of 15W to the PD, and this can be a problem during startup. Low power PDs that are used in these legacy systems will require a lower startup current limit. The LM5070 can be programmed for a reduced inrush current limit level with a resistor at RCLP pin. The programmable inrush current limit range is 75mA to 390mA. If the RCLP pin is left open, the LM5070 will default to 390mA, near the maximum allowed per the IEEE 802.3 specification. To set a desired inrush current limit (limit), the RCLP resistor can be calculated from:

$$RCLP = \frac{16000\Omega \cdot A}{I_{\text{limit}} (A)} \quad (1)$$

The SMPS controller will not initiate operation until the load capacitor is completely charged. The power sequencing between the interface circuitry and the SMPS controller occurs automatically within the LM5070. Detection circuitry monitors the RTN pin to detect interface startup completion. When the RTN pin potential drops below 1.5V with respect to  $V_{EE}$ , the  $V_{CC}$  regulator of the SMPS controller is enabled. The soft-start function is enabled once the  $V_{CC}$  regulator achieves minimum operating voltage. The RCLP programmed inrush current limit only applies to the initial charging phase. The interface power MOSFET current limit will revert to the fixed default protection current limit of 390mA once the SMPS is powered up and the soft-start pin sequence begins.

### High Voltage Start-Up Regulator

The LM5070 contains an internal high voltage startup regulator that allows the input pin ( $V_{IN}$ ) to be connected directly to line voltages as high as 75V. The regulator output is internally current limited to 15mA. The recommended capacitance range for the  $V_{CC}$  regulator output is 0.1uF to 10uF. When the voltage on the  $V_{CC}$  pin reaches the regulation point of 7.8V, the controller output is enabled. The controller will remain enabled until  $V_{CC}$  falls below 6.25V.

In typical applications, a transformer auxiliary winding is diode connected to the  $V_{CC}$  pin. This winding should raise the  $V_{CC}$  voltage above 8.1V to shut off the internal startup regulator. Though not required, powering  $V_{CC}$  from an auxiliary winding improves conversion efficiency while reducing the power dissipated in the controller. The external  $V_{CC}$  capacitor must be selected such that the capacitor maintains the  $V_{CC}$  voltage greater than the  $V_{CC}$  UVLO falling threshold (6.25V) during the initial start-up. During a fault condition when the converter auxiliary winding is inactive, external current draw on the  $V_{CC}$  line should be limited such that the power dissipated in the start-up regulator does not exceed the maximum power dissipation capability of the LM5070 package.

### Error Amplifier

An internal high gain error amplifier is provided within the LM5070. The amplifier's non-inverting reference is set to a fixed reference voltage of 1.25V. The inverting input is connected to the FB pin. In non-isolated applications, the power converter output is connected to the FB pin via voltage scaling resistors. Loop compensation components are connected between the COMP and FB pins. For most isolated applications the error amplifier function is implemented on the secondary side of the converter and the internal error amplifier is not used. The internal error amplifier is configured as an open drain output and can be disabled by connecting the FB pin to ARTN. An internal 5K pull-up resistor between a 5V reference and COMP can be used as the pull-up for an optocoupler in isolated applications.

### Current Limit / Current Sense

The LM5070 provides a cycle-by-cycle over current protection function. Current limit is accomplished by an internal current sense comparator. If the voltage at the current sense comparator input CS exceeds 0.5V with respect to RTN/ARTN, the output pulse will be immediately terminated. A small RC filter, located near the CS pin of the controller, is recommended to filter noise from the current sense signal. The CS input has an internal MOSFET which discharges the CS pin capacitance at the conclusion of every cycle. The discharge device remains on an additional 50ns after the beginning of the new cycle to attenuate the leading edge spike on the current sense signal.

The LM5070 current sense and PWM comparators are very fast, and may respond to short duration noise pulses. Layout considerations are critical for the current sense filter and sense resistor. The capacitor associated with the CS filter must be located very close to the device and connected directly to the pins of the controller (CS and ARTN). If a current sense transformer is used, both leads of the transformer secondary should be routed to the sense resistor and the current sense filter network. A sense resistor located in the source of the primary power MOSFET may be used for current sensing, but a low inductance resistor is required. When designing with a current sense resistor, all of the noise sensitive low power ground connections should be connected together local to the controller and a single connection should be made to the high current power return (sense resistor ground point).

### Oscillator, Shutdown and Sync Capability

A single external resistor connected between the RT and ARTN pins sets the LM5070 oscillator frequency. Internal to the LM5070–50 device (50% duty cycle limited option) is an oscillator divide by two circuit. This divide by two circuit creates an exact 50% duty cycle clock which is used internally to create a precise 50% duty cycle limit function. Because of this divide by two, the internal oscillator actually operates at twice the frequency of the output (OUT). For the LM5070–80 device the oscillator frequency and the operational output frequency are the same. To set a desired output operational frequency (F), the RT resistor can be calculated from:

LM5070-80:

$$RT = \frac{1}{F \times 165 \times 10^{-12}} \quad (2)$$

LM5070-50:

$$RT = \frac{1}{F \times 330 \times 10^{-12}} \quad (3)$$

The LM5070 can also be synchronized to an external clock. The external clock must have a higher frequency than the free running oscillator frequency set by the RT resistor. The clock signal should be capacitively coupled into the RT pin with a 100pF capacitor. A peak voltage level greater than 3.7 volts at the RT pin is required for detection of the sync pulse. The sync pulse width should be set between 15 to 150ns by the external components. The RT resistor is always required, whether the oscillator is free running or externally synchronized. The voltage at the RT pin is internally regulated to a 2 volts. The RT resistor should be located very close to the device and connected directly to the pins of the controller (RT and ARTN).

### PWM Comparator / Slope Compensation

The PWM comparator compares the current ramp signal with the loop error voltage derived from the error amplifier output. The error amplifier output voltage at the COMP pin is offset by 1.4V and then further attenuated by a 3:1 resistor divider. The PWM comparator polarity is such that 0 Volts on the COMP pin will result in zero duty cycle at the controller output. For duty cycles greater than 50 percent, current mode control circuits are subject to sub-harmonic oscillation. By adding an additional fixed slope voltage ramp signal (slope compensation) to the current sense signal, this oscillation can be avoided. The LM5070-80 integrates this slope compensation by summing a current ramp generated by the oscillator with the current sense signal. Additional slope compensation may be added by increasing the source impedance of the current sense signal (with an external resistor between the CS pin and current sense resistor). Since the LM5070-50 is not capable of duty cycles greater than 50%, there is no slope compensation feature in this device.

### Softstart

The softstart feature allows the power converter to gradually reach the initial steady state operating point, thereby reducing start-up stresses, output overshoot and current surges. At power on, after the  $V_{CC}$  undervoltage lockout threshold is satisfied, an internal 10 $\mu$ A current source charges an external capacitor connected to the SS pin. The capacitor voltage will ramp up slowly and will limit the COMP pin voltage and the duty cycle of the output pulses.

## Gate Driver and Maximum Duty Cycle Limit

The LM5070 provides an internal gate driver (OUT), which can source and sink a peak current of 800mA. The LM5070 is available in two duty cycle limit options. The maximum output duty cycle is typically 80% for the LM5070-80 option and precisely equal to 50% for the LM5070-50 option. The maximum duty cycle function for the LM5070-50 is accomplished with an internal toggle flip-flop which ensures an accurate duty cycle limit. The internal oscillator frequency of the LM5070-50 is therefore twice the operating frequency of the PWM controller (OUT pin).

The 80% maximum duty cycle limit of the LM5070-80 is determined by the internal oscillator and varies more than the 50% limit of the LM5070-50. For the LM5070-80, the internal oscillator frequency and the operational frequency of the PWM controller are equal.

## Thermal Protection

Internal thermal shutdown circuitry is provided to protect the integrated circuit in the event the maximum junction temperature is exceeded. This feature prevents catastrophic failures from accidental device overheating. When activated, typically at 165 degrees Celsius, the controller is forced into a low power standby state, disabling the output driver, bias regulator, main interface pass MOSFET, and classification regulator if enabled. After the temperature is reduced (typical hysteresis = 25°C) the  $V_{CC}$  regulator will be enabled and a softstart sequence initiated.



LM5070 Application Circuit – Isolated Output with Synchronous Rectification

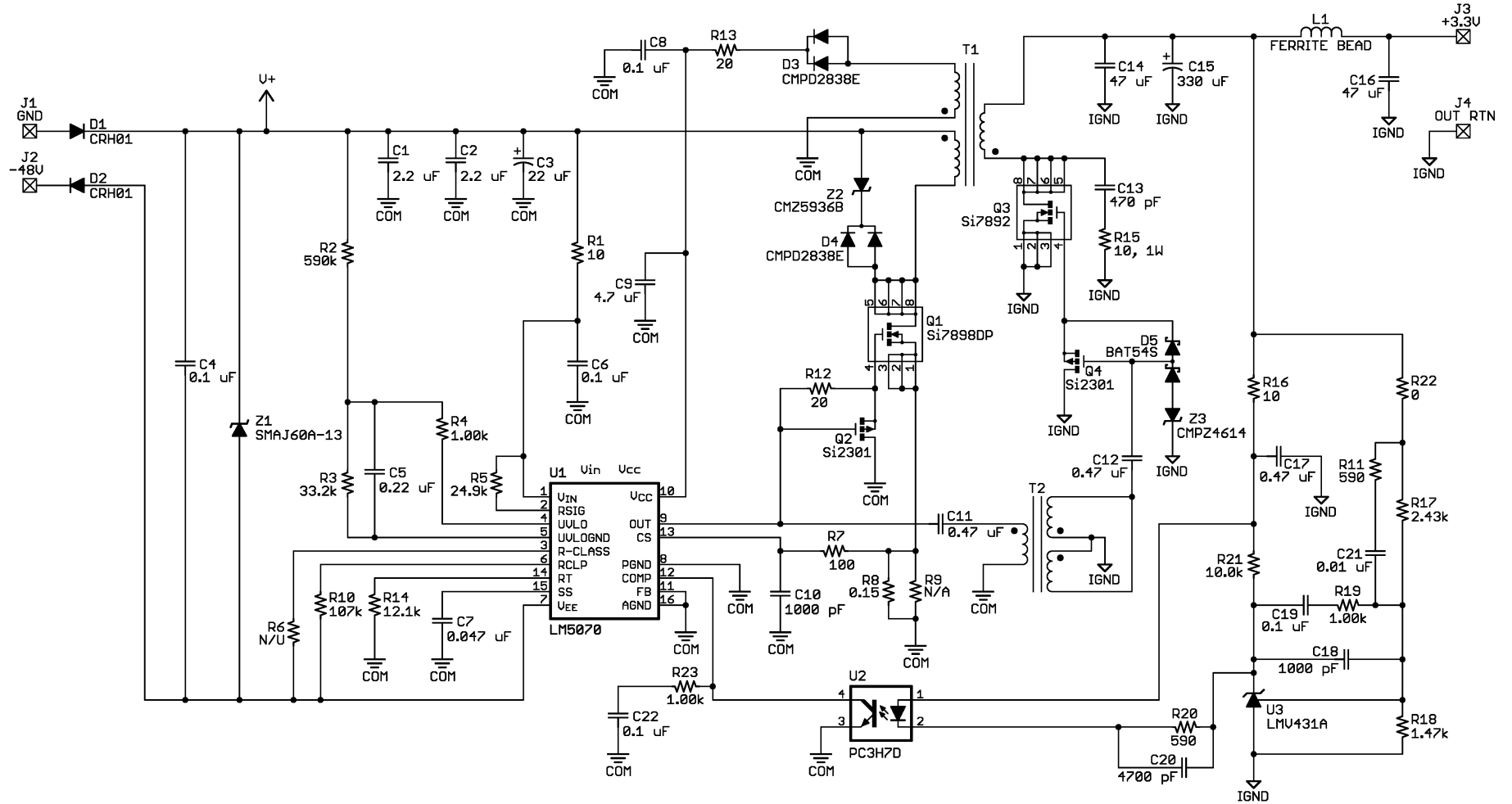

---

**REVISION HISTORY**

<b>Changes from Revision F (April 2013) to Revision G</b>	<b>Page</b>
<hr/> <ul style="list-style-type: none"><li>• Changed layout of National Data Sheet to TI format .....</li></ul>	<hr/> <b>16</b>

**PACKAGING INFORMATION**

Orderable Device	Status (1)	Package Type	Package Drawing	Pins	Package Qty	Eco Plan (2)	Lead/Ball Finish (6)	MSL Peak Temp (3)	Op Temp (°C)	Device Marking (4/5)	Samples
LM5070MTC-50/NOPB	ACTIVE	TSSOP	PW	16	92	Green (RoHS & no Sb/Br)	CU SN	Level-1-260C-UNLIM	-40 to 125	5070M TC-50	<a href="#">Samples</a>
LM5070MTC-80/NOPB	ACTIVE	TSSOP	PW	16	92	Green (RoHS & no Sb/Br)	CU SN	Level-1-260C-UNLIM	-40 to 125	5070M TC-80	<a href="#">Samples</a>
LM5070MTCX-50/NOPB	ACTIVE	TSSOP	PW	16	2500	Green (RoHS & no Sb/Br)	CU SN	Level-1-260C-UNLIM	-40 to 125	5070M TC-50	<a href="#">Samples</a>
LM5070MTCX-80/NOPB	ACTIVE	TSSOP	PW	16	2500	Green (RoHS & no Sb/Br)	CU SN	Level-1-260C-UNLIM	-40 to 125	5070M TC-80	<a href="#">Samples</a>
LM5070SD-50/NOPB	ACTIVE	WSON	NHQ	16	1000	Green (RoHS & no Sb/Br)	CU SN	Level-1-260C-UNLIM	-40 to 125	L00051B	<a href="#">Samples</a>

(1) The marketing status values are defined as follows:

**ACTIVE:** Product device recommended for new designs.

**LIFEBUY:** TI has announced that the device will be discontinued, and a lifetime-buy period is in effect.

**NRND:** Not recommended for new designs. Device is in production to support existing customers, but TI does not recommend using this part in a new design.

**PREVIEW:** Device has been announced but is not in production. Samples may or may not be available.

**OBSOLETE:** TI has discontinued the production of the device.

(2) **RoHS:** TI defines "RoHS" to mean semiconductor products that are compliant with the current EU RoHS requirements for all 10 RoHS substances, including the requirement that RoHS substance do not exceed 0.1% by weight in homogeneous materials. Where designed to be soldered at high temperatures, "RoHS" products are suitable for use in specified lead-free processes. TI may reference these types of products as "Pb-Free".

**RoHS Exempt:** TI defines "RoHS Exempt" to mean products that contain lead but are compliant with EU RoHS pursuant to a specific EU RoHS exemption.

**Green:** TI defines "Green" to mean the content of Chlorine (Cl) and Bromine (Br) based flame retardants meet JS709B low halogen requirements of <=1000ppm threshold. Antimony trioxide based flame retardants must also meet the <=1000ppm threshold requirement.

(3) MSL, Peak Temp. - The Moisture Sensitivity Level rating according to the JEDEC industry standard classifications, and peak solder temperature.

(4) There may be additional marking, which relates to the logo, the lot trace code information, or the environmental category on the device.

(5) Multiple Device Markings will be inside parentheses. Only one Device Marking contained in parentheses and separated by a "-" will appear on a device. If a line is indented then it is a continuation of the previous line and the two combined represent the entire Device Marking for that device.

(6) Lead/Ball Finish - Orderable Devices may have multiple material finish options. Finish options are separated by a vertical ruled line. Lead/Ball Finish values may wrap to two lines if the finish value exceeds the maximum column width.

**Important Information and Disclaimer:** The information provided on this page represents TI's knowledge and belief as of the date that it is provided. TI bases its knowledge and belief on information provided by third parties, and makes no representation or warranty as to the accuracy of such information. Efforts are underway to better integrate information from third parties. TI has taken and continues to take reasonable steps to provide representative and accurate information but may not have conducted destructive testing or chemical analysis on incoming materials and chemicals. TI and TI suppliers consider certain information to be proprietary, and thus CAS numbers and other limited information may not be available for release.

In no event shall TI's liability arising out of such information exceed the total purchase price of the TI part(s) at issue in this document sold by TI to Customer on an annual basis.

**TAPE AND REEL INFORMATION**

**QUADRANT ASSIGNMENTS FOR PIN 1 ORIENTATION IN TAPE**

\*All dimensions are nominal

Device	Package Type	Package Drawing	Pins	SPQ	Reel Diameter (mm)	Reel Width W1 (mm)	A0 (mm)	B0 (mm)	K0 (mm)	P1 (mm)	W (mm)	Pin1 Quadrant
LM5070MTCX-50/NOPB	TSSOP	PW	16	2500	330.0	12.4	6.95	5.6	1.6	8.0	12.0	Q1
LM5070MTCX-80/NOPB	TSSOP	PW	16	2500	330.0	12.4	6.95	5.6	1.6	8.0	12.0	Q1
LM5070SD-50/NOPB	WSO	NHQ	16	1000	178.0	12.4	5.3	5.3	1.3	8.0	12.0	Q1

**TAPE AND REEL BOX DIMENSIONS**

\*All dimensions are nominal

Device	Package Type	Package Drawing	Pins	SPQ	Length (mm)	Width (mm)	Height (mm)
LM5070MTCX-50/NOPB	TSSOP	PW	16	2500	367.0	367.0	35.0
LM5070MTCX-80/NOPB	TSSOP	PW	16	2500	367.0	367.0	35.0
LM5070SD-50/NOPB	WSON	NHQ	16	1000	210.0	185.0	35.0

NHQ0016A

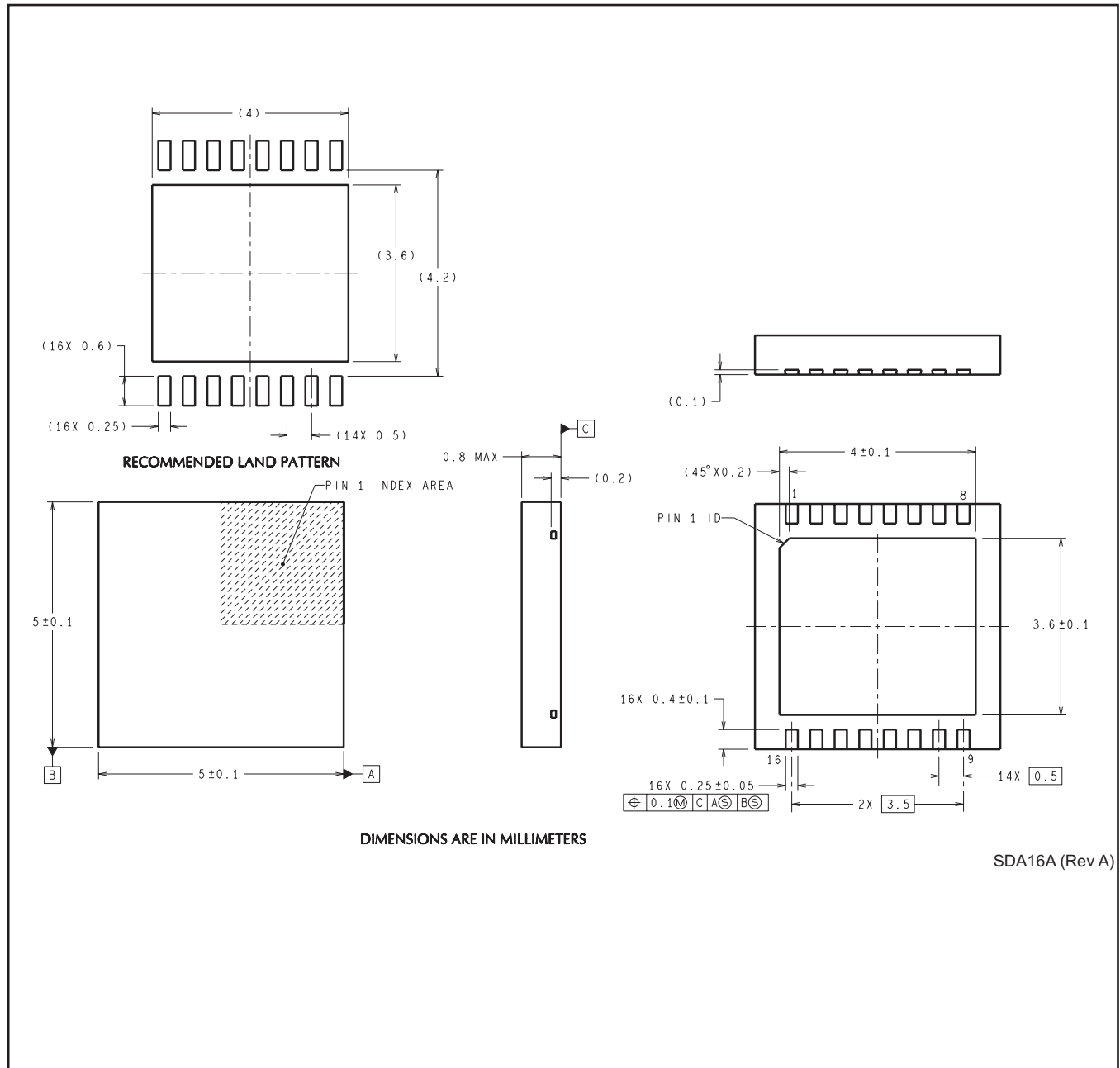



4220204/A 02/2017

NOTES:

- All linear dimensions are in millimeters. Any dimensions in parenthesis are for reference only. Dimensioning and tolerancing per ASME Y14.5M.
- This drawing is subject to change without notice.
- This dimension does not include mold flash, protrusions, or gate burrs. Mold flash, protrusions, or gate burrs shall not exceed 0.15 mm per side.
- This dimension does not include interlead flash. Interlead flash shall not exceed 0.25 mm per side.
- Reference JEDEC registration MO-153.

# EXAMPLE BOARD LAYOUT

PW0016A

TSSOP - 1.2 mm max height

SMALL OUTLINE PACKAGE



LAND PATTERN EXAMPLE  
EXPOSED METAL SHOWN  
SCALE: 10X



4220204/A 02/2017

NOTES: (continued)

- 6. Publication IPC-7351 may have alternate designs.
- 7. Solder mask tolerances between and around signal pads can vary based on board fabrication site.

# EXAMPLE STENCIL DESIGN

PW0016A

TSSOP - 1.2 mm max height

SMALL OUTLINE PACKAGE



SOLDER PASTE EXAMPLE  
BASED ON 0.125 mm THICK STENCIL  
SCALE: 10X

4220204/A 02/2017

NOTES: (continued)

8. Laser cutting apertures with trapezoidal walls and rounded corners may offer better paste release. IPC-7525 may have alternate design recommendations.
9. Board assembly site may have different recommendations for stencil design.

## IMPORTANT NOTICE AND DISCLAIMER

TI PROVIDES TECHNICAL AND RELIABILITY DATA (INCLUDING DATASHEETS), DESIGN RESOURCES (INCLUDING REFERENCE DESIGNS), APPLICATION OR OTHER DESIGN ADVICE, WEB TOOLS, SAFETY INFORMATION, AND OTHER RESOURCES "AS IS" AND WITH ALL FAULTS, AND DISCLAIMS ALL WARRANTIES, EXPRESS AND IMPLIED, INCLUDING WITHOUT LIMITATION ANY IMPLIED WARRANTIES OF MERCHANTABILITY, FITNESS FOR A PARTICULAR PURPOSE OR NON-INFRINGEMENT OF THIRD PARTY INTELLECTUAL PROPERTY RIGHTS.

These resources are intended for skilled developers designing with TI products. You are solely responsible for (1) selecting the appropriate TI products for your application, (2) designing, validating and testing your application, and (3) ensuring your application meets applicable standards, and any other safety, security, or other requirements. These resources are subject to change without notice. TI grants you permission to use these resources only for development of an application that uses the TI products described in the resource. Other reproduction and display of these resources is prohibited. No license is granted to any other TI intellectual property right or to any third party intellectual property right. TI disclaims responsibility for, and you will fully indemnify TI and its representatives against, any claims, damages, costs, losses, and liabilities arising out of your use of these resources.

TI's products are provided subject to TI's Terms of Sale ([www.ti.com/legal/termsofsale.html](http://www.ti.com/legal/termsofsale.html)) or other applicable terms available either on [ti.com](http://ti.com) or provided in conjunction with such TI products. TI's provision of these resources does not expand or otherwise alter TI's applicable warranties or warranty disclaimers for TI products.

Mailing Address: Texas Instruments, Post Office Box 655303, Dallas, Texas 75265  
Copyright © 2019, Texas Instruments Incorporated

## Looking for pricing, stock, or lifecycle information?

Click below to explore more details on WIN SOURCE:

- ⊖ [View LM5070MTCX-50/NOPB on WIN SOURCE](#)
- ⊖ [Texas Instruments](#) Information

## Optimize Your Supply Chain with WIN SOURCE Solutions

- ✓ Global Sourcing Solution
- ✓ Obsolete Management
- ✓ Cost Control Management
- ✓ Shortage Management
- ✓ Alternative Solution
- ✓ Excess Inventory Management