



THE DATASHEET OF LM4913MH/NOPB



LM4913 Boomer® Audio Power Amplifier Series 2W Monaural, 90mW Stereo Headphone Audio Amplifier

Check for Samples: [LM4913](#)

FEATURES

- Advanced "Click and Pop" Suppression Circuitry
- Stereo Headphone Amplifier Mode
- Low Current Micro-Power Shutdown Mode
- Thermal Shutdown Protection Circuitry
- 2.5V to 5.5V Operation
- Unity-Gain Stable
- Gain Set with External Resistors
- Space-Saving Exposed-DAP VSSOP Package

KEY SPECIFICATIONS

- BTL Output Power ($R_L = 4\Omega$)
 - $V_{DD} = \text{at } 3.0\text{V}$, THD = 1%: 660mW (typ)
 - $V_{DD} = \text{at } 5.0\text{V}$, THD = 0.3%: 2W (typ)
- SE Output Power ($R_L = 32\Omega$ and THD = 0.1%)
 - $V_{DD} = \text{at } 3.0\text{V}$: 33mW (typ)
 - $V_{DD} = \text{at } 5.0\text{V}$: 90mW (typ)
- Micro-Power Shutdown Supply Current: 1 μA (typ)
- PSRR (@ 1kHz, $2.9\text{V} \leq V_{DD} \leq 5.1\text{V}$, (Figure 1))
 - BTL: 52dB (typ)
 - SE: 62dB (typ)

APPLICATIONS

- PDAs
- Cellular Phones
- Handheld Portable Electronic Devices

DESCRIPTION

The unity-gain stable LM4913 is both a mono differential output (for bridge-tied loads, or BTL) audio power amplifier and a single-ended (SE) stereo headphone amplifier. Operating on a single 5V supply, the mono BTL mode delivers 2W (typ) to a 4 Ω load ⁽¹⁾ at 0.3% THD+N. In SE stereo mode, the amplifier will deliver 90mW to 32 Ω loads. The LM4913 features circuitry that suppresses output transients ("clicks and pops").

The LM4913 is designed for notebook and other handheld portable applications. It delivers high quality output power from a surface-mount package and requires few external components. The LM4913 is pin and functionally compatible with the TPA0213.

Other features include an active-low micro-power shutdown mode and thermal shutdown protection.

The LM4913 is available in a space efficient 10-lead exposed-DAP VSSOP package.

- (1) **Note:** When operating on a 5V_{DC} supply, an LM4913MH that has been properly mounted to a circuit board will deliver 2W into 4 Ω . See the [Application Information](#) sections for further information concerning PCB layout suggestions to maximize the LM4913MH's output power with a 4 Ω load.

Connection Diagram

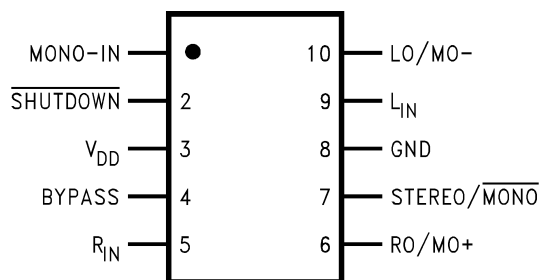

10 Pin TSSOP - Top View
Package Number DGQ



Please be aware that an important notice concerning availability, standard warranty, and use in critical applications of Texas Instruments semiconductor products and disclaimers thereto appears at the end of this data sheet.

All trademarks are the property of their respective owners.

Typical Application

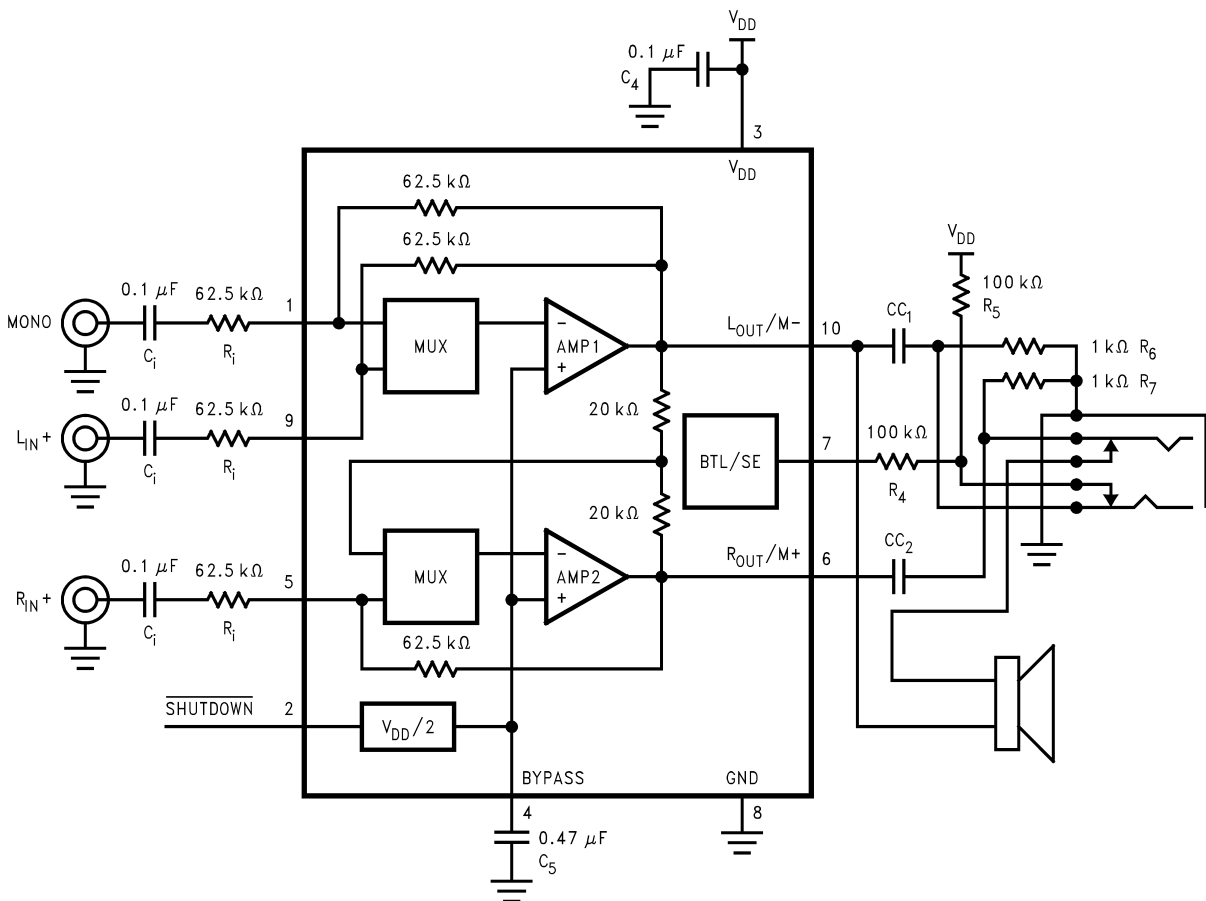

Figure 1. Typical Audio Amplifier Application Circuit



These devices have limited built-in ESD protection. The leads should be shorted together or the device placed in conductive foam during storage or handling to prevent electrostatic damage to the MOS gates.

Absolute Maximum Ratings ⁽¹⁾⁽²⁾⁽³⁾

Supply Voltage	6.0V
Storage Temperature	–65°C to +150°C
Input Voltage	–0.3V to $V_{DD} + 0.3V$
Power Dissipation ⁽⁴⁾	Internally Limited
ESD Susceptibility ⁽⁵⁾	2000V
ESD Susceptibility ⁽⁶⁾	200V
Junction Temperature	150°C
Solder Information	
Small Outline Package	
Vapor Phase (60sec)	215°C
Infrared (15sec)	220°C
Thermal Resistance	
θ_{JA} (DGQ)	46°C/W ⁽⁷⁾

- (1) All voltages are measured with respect to the ground pin, unless otherwise specified.
- (2) *Absolute Maximum Ratings* indicate limits beyond which damage to the device may occur. *Operating Ratings* indicate conditions for which the device is functional, but do not ensure specific performance limits. *Electrical Characteristics* state DC and AC electrical specifications under particular test conditions which ensure specific performance limits. This assumes that the device is within the Operating Ratings. Specifications are not ensured for parameters where no limit is given, however, the typical value is a good indication of device performance.
- (3) If Military/Aerospace specified devices are required, please contact the Texas Instruments Sales Office/ Distributors for availability and specifications.
- (4) The maximum power dissipation must be derated at elevated temperatures and is dictated by T_{JMAX} , θ_{JA} , and the ambient temperature T_A . The maximum allowable power dissipation is $P_{DMAX} = (T_{JMAX} - T_A) / \theta_{JA}$ or the number given in Absolute Maximum Ratings, whichever is lower.
- (5) Human body model, 100pF discharged through a 1.5k Ω resistor.
- (6) Machine Model, 220pF–240pF discharged through all pins.
- (7) The given θ_{JA} is for an LM4913 packaged in a DGQ with the Exposed-DAP soldered to an exposed 2in² area of 1oz printed circuit board copper.

Operating Ratings

Temperature Range	
$T_{MIN} \leq T_A \leq T_{MAX}$	–40°C $\leq T_A \leq$ 85°C
Supply Voltage	2.5V $\leq V_{DD} \leq$ 5.5V

Electrical Characteristics for Entire Amplifier ($V_{DD} = 5V$)

The following specifications apply for the circuit shown in [Figure 1](#) unless otherwise specified. Limits apply for $T_A = 25^\circ\text{C}$. ⁽¹⁾

Symbol	Parameter	Conditions	LM4913		Units (Limits)
			Typical ⁽¹⁾	Limit	
⁽²⁾⁽³⁾ V_{DD}	Supply Voltage			2.5 5.5	V (min) V (max)
I_{DD}	Quiescent Power Supply Current	$V_{IN} = 0V, I_O = 0A$, No Load	4	8	mA (max)
I_{SD}	Shutdown Quiescent Power Supply Current	$V_{SHUTDOWN} = GND$	1	6	μA (max)
R_{IN}	Input Resistance			50	k Ω
V_{OS}	Output Offset Voltage		5	30	mV (max)
PSRR	Power Supply Rejection Ratio	$V_{DD} = 3V, C_{BYPASS} = 0.47\mu F$, $V_{ripple} = 200mVp-p$ 1kHz sine wave BTL, $R_L = 4\Omega$ BTL, SE, $R_L = 32\Omega$	58 60		dB dB
HP- S_{VIH}	HP-SENSE Logic-High Threshold Voltage			4.5	V (min)

- (1) Typicals are measured at 25°C and represent the parametric norm.
- (2) Limits are specified to AOQL (Average Outgoing Quality Level).
- (3) Datasheet minimum and maximum specification limits are specified by design, test, or statistical analysis.

Electrical Characteristics for Entire Amplifier ($V_{DD} = 5V$) (continued)

The following specifications apply for the circuit shown in Figure 1 unless otherwise specified. Limits apply for $T_A = 25^\circ\text{C}$.⁽¹⁾

Symbol	Parameter	Conditions	LM4913		Units (Limits)
			Typical	Limit	
			(1)		
HP-S _{VIL}	HP-SENSE Logic-Low Threshold Voltage			2.75	V (max)
SD _{VIH}	Shutdown Logic High Threshold			2.0	V (min)
SD _{VIL}	Shutdown Logic Low Threshold			0.8	V (max)

Electrical Characteristics: Bridged-Mode Operation ($V_{DD} = 5V$)

The following specifications apply for the circuit shown in Figure 1, $R_L = 4\Omega$, and a measurement bandwidth of 20Hz to 80kHz, unless otherwise specified. Limits apply for $T_A = 25^\circ\text{C}$.⁽¹⁾

Symbol	Parameter	Conditions	LM4913		Units (Limits)
			Typical	Limit	
			(1)		
⁽²⁾⁽³⁾ P _O	Output Power ⁽⁴⁾	THD = 0.3% (max); f = 1kHz $R_L = 4\Omega$ ⁽⁵⁾	2		W
THD+N	Total Harmonic Distortion + Noise	$R_L = 4\Omega$, P _O = 1.5W, f = 1kHz	0.2		%
V _{ON}	Output Voltage Noise	C _B = 0.47 μ F, 20Hz < f < 20kHz	21		μ V _{RMS}

(1) Typicals are measured at 25°C and represent the parametric norm.

(2) Limits are specified to AOQL (Average Outgoing Quality Level).

(3) Datasheet minimum and maximum specification limits are specified by design, test, or statistical analysis.

(4) Output power is measured at the amplifier's package pins.

(5) When driving 4 Ω loads and operating on a 5V supply, the LM4913MH must be mounted to a circuit board that has a minimum of 2.5in² of exposed, uninterrupted copper area connected to the MH package's exposed DAP.

Electrical Characteristics: SE Operation ($V_{DD} = 5V$)

The following specifications apply for the circuit shown in Figure 1, $R_L = 4\Omega$, and a measurement bandwidth of 20Hz to 80kHz, unless otherwise specified. Limits apply for $T_A = 25^\circ\text{C}$.⁽¹⁾

Symbol	Parameter	Conditions	LM4913		Units (Limits)
			Typical	Limit	
			(1)		
⁽²⁾⁽³⁾ P _O	Output Power ⁽⁴⁾	THD+N = 0.1%, f = 1kHz, $R_L = 32\Omega$	90		mW
THD+N	Total Harmonic Distortion + Noise	f = 1kHz $R_L = 32\Omega$, P _O = 70mW	0.2		% %
V _{ON}	Output Voltage Noise	C _B = 0.47 μ F, 20Hz < f < 20kHz	12		μ V _{RMS}

(1) Typicals are measured at 25°C and represent the parametric norm.

(2) Limits are specified to AOQL (Average Outgoing Quality Level).

(3) Datasheet minimum and maximum specification limits are specified by design, test, or statistical analysis.

(4) Output power is measured at the amplifier's package pins.

Electrical Characteristics for Entire Amplifier ($V_{DD} = 3V$)

The following specifications apply for the circuit shown in Figure 1 unless otherwise specified. Limits apply for $T_A = 25^\circ\text{C}$.⁽¹⁾

Symbol	Parameter	Conditions	LM4913		Units (Limits)
			Typical	Limit	
			(1)		
⁽²⁾⁽³⁾ V _{DD}	Supply Voltage			2.7 5.5	V (min) V (max)
I _{DD}	Quiescent Power Supply Current	V _{IN} = 0V, I _O = 0A, No Load	3	7	mA (max)

(1) Typicals are measured at 25°C and represent the parametric norm.

(2) Limits are specified to AOQL (Average Outgoing Quality Level).

(3) Datasheet minimum and maximum specification limits are specified by design, test, or statistical analysis.

Electrical Characteristics for Entire Amplifier ($V_{DD} = 3V$) (continued)

The following specifications apply for the circuit shown in [Figure 1](#) unless otherwise specified. Limits apply for $T_A = 25^\circ\text{C}$.⁽¹⁾

Symbol	Parameter	Conditions	LM4913		Units (Limits)
			Typical (1)	Limit	
I_{SD}	Shutdown Quiescent Power Supply Current	$V_{SHUTDOWN} = GND$	1	4	μA (max)
V_{OS}	Output Offset Voltage		7	30	mV (max)
PSRR	Power Supply Rejection Ratio	$V_{DD} = 3V$, $C_{BYPASS} = 0.47\mu\text{F}$, $V_{ripple} = 200\text{mVp-p}$ 1kHz sine wave BTL, $R_L = 8\Omega$ BTL, SE, $R_L = 32\Omega$	58 60		dB dB
HP- S_{VIH}	HP-SENSE Logic-High Threshold Voltage			2.7	V (min)
HP- S_{VIL}	HP-SENSE Logic-Low Threshold Voltage			1.65	V (max)
SD_{VIH}	Shutdown Logic High Threshold			2	V (min)
SD_{VIL}	Shutdown Logic Low Threshold			0.8	V (max)

Electrical Characteristics: Bridged-Mode Operation ($V_{DD} = 3V$)

The following specifications apply for the circuit shown in [Figure 1](#), $R_L = 4\Omega$, and a measurement bandwidth of 20Hz to 80kHz, unless otherwise specified. Limits apply for $T_A = 25^\circ\text{C}$.⁽¹⁾

Symbol	Parameter	Conditions	LM4913		Units (Limits)
			Typical (1)	Limit	
⁽²⁾⁽³⁾ P_O	Output Power ⁽⁴⁾	THD = 1% (max); $f = 1\text{kHz}$ ⁽⁵⁾ $R_L = 4\Omega$ (THD = 0.1%)	660		W
THD+N	Total Harmonic Distortion + Noise	$f = 1\text{kHz}$ $R_L = 4\Omega$, $P_O = 500\text{mW}$	0.2		%
V_{ON}	Output Voltage Noise	$C_B = 0.47\mu\text{F}$, $20\text{Hz} < f < 20\text{kHz}$	21		μV_{RMS}

(1) Typicals are measured at 25°C and represent the parametric norm.

(2) Limits are specified to AOQL (Average Outgoing Quality Level).

(3) Datasheet minimum and maximum specification limits are specified by design, test, or statistical analysis.

(4) Output power is measured at the amplifier's package pins.

(5) When driving 4Ω loads and operating on a 5V supply, the LM4913MH must be mounted to a circuit board that has a minimum of 2.5in^2 of exposed, uninterrupted copper area connected to the MH package's exposed DAP.

Electrical Characteristics: SE Operation ($V_{DD} = 3V$)⁽¹⁾

The following specifications apply for the circuit shown in [Figure 1](#), $R_L = 4\Omega$, and a measurement bandwidth of 20Hz to 80kHz, unless otherwise specified. Limits apply for $T_A = 25^\circ\text{C}$.⁽²⁾

Symbol	Parameter	Conditions	LM4913		Units (Limits)
			Typical (2)	Limit	
⁽³⁾⁽⁴⁾ P_O	Output Power ⁽⁵⁾	THD+N = 0.1%, $f = 1\text{kHz}$, $R_L = 32\Omega$	33	30	mW
THD+N	Total Harmonic Distortion + Noise	$f = 1\text{kHz}$ $R_L = 32\Omega$, $P_O = 30\text{mW}$	0.1		%
V_{ON}	Output Voltage Noise	$C_B = 0.47\mu\text{F}$, $20\text{Hz} < f < 20\text{kHz}$	12		μV_{RMS}

(1) See Application Information section "[Bridge \(BTL\) OR Single-Ended \(SE\) Configuration Explanation](#)" for more information.

(2) Typicals are measured at 25°C and represent the parametric norm.

(3) Limits are specified to AOQL (Average Outgoing Quality Level).

(4) Datasheet minimum and maximum specification limits are specified by design, test, or statistical analysis.

(5) Output power is measured at the amplifier's package pins.

External Components Description

(see [Figure 1](#))

Components		Functional Description
1.	R_i	This is the input resistor for the inverting input that, along with the 62.5k Ω internal feedback resistor R_f , sets the first stage's closed-loop gain. The overall SE gain is $A_V (SE) = 62.5k\Omega / R_i$, whereas the overall BTL gain is $A_V (BTL) = -125k\Omega / R_i$. Input resistance R_i and input capacitance C_i form a high pass filter. The filter's cutoff frequency is filter's cutoff frequency is $f_C = 1 / 2\pi R_i C_i$.
2.	C_i	This is the input coupling capacitor. It blocks DC voltage at the amplifier's inverting input. C_i and R_i create a highpass filter. The filter's cutoff frequency is $f_C = 1 / 2\pi R_i C_i$. Refer to the Application Information section, Selecting External Components , for an explanation of determining C_i 's value.
3.	C_C	This is the output coupling capacitor. Refer to the Application Information section, Selecting External Components , for an explanation of determining C_C 's value.
4.	C_S	The supply bypass capacitor. Refer to the Power Supply Bypassing section for information about properly placing, and selecting the value of this capacitor.
5.	C_B	This capacitor filters the half-supply voltage present on the BYPASS pin. Refer to the Application Information section, Selecting External Components , for information about properly placing, and selecting the value of this capacitor.

Typical Performance Characteristics

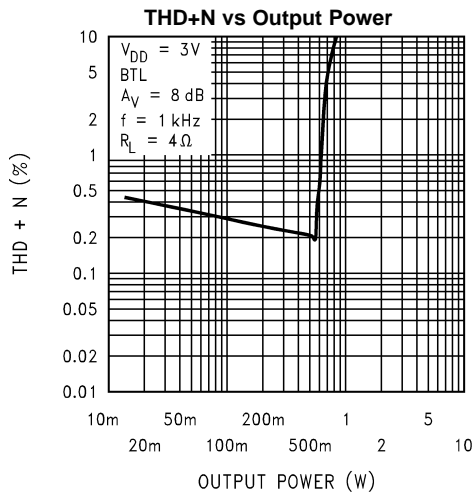

Figure 2.

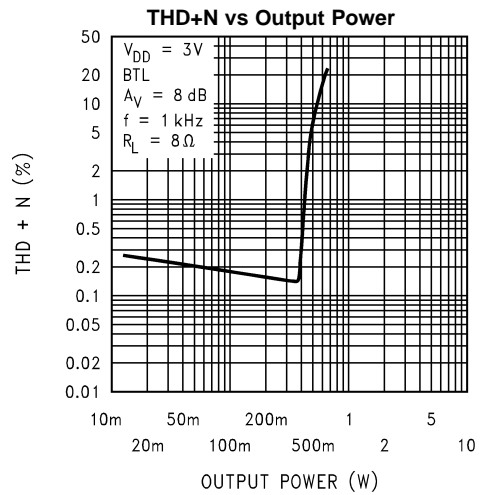

Figure 3.

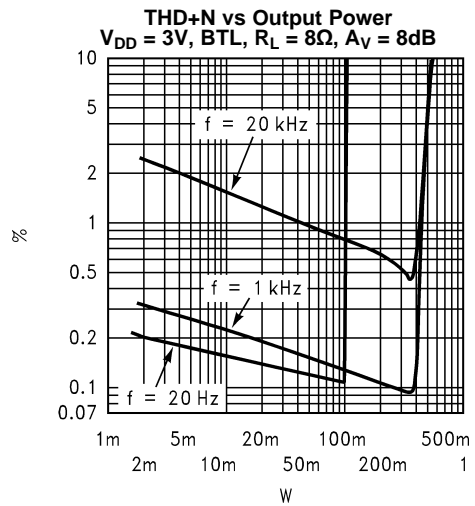

Figure 4.

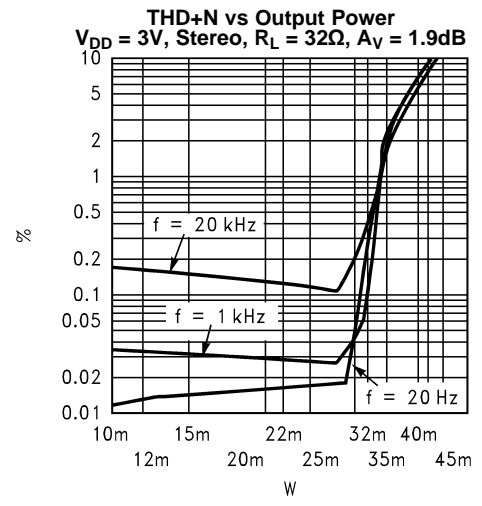

Figure 5.

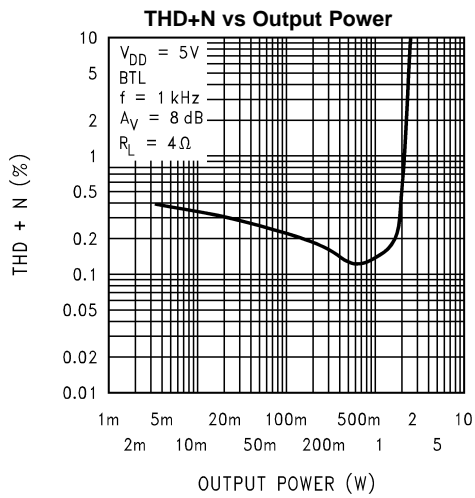

Figure 6.

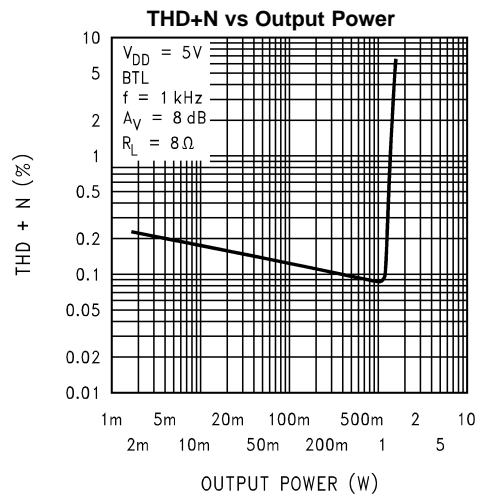

Figure 7.

Typical Performance Characteristics (continued)

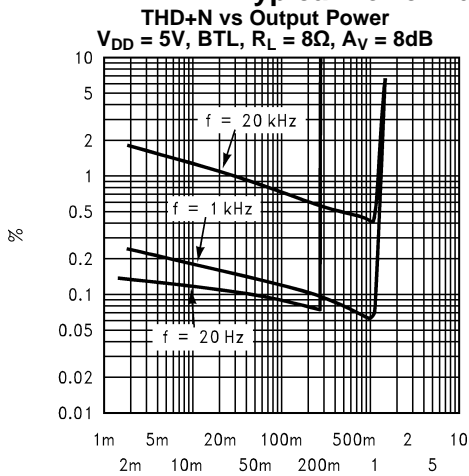

Figure 8.

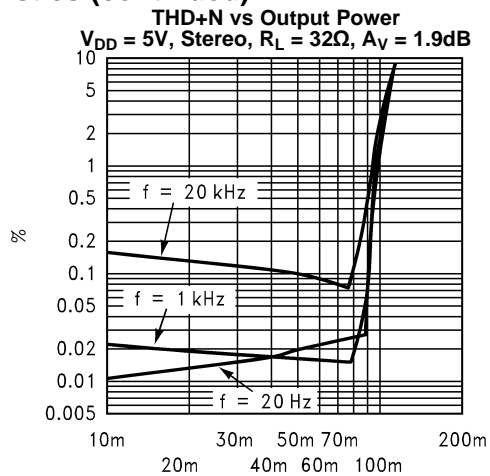

Figure 9.

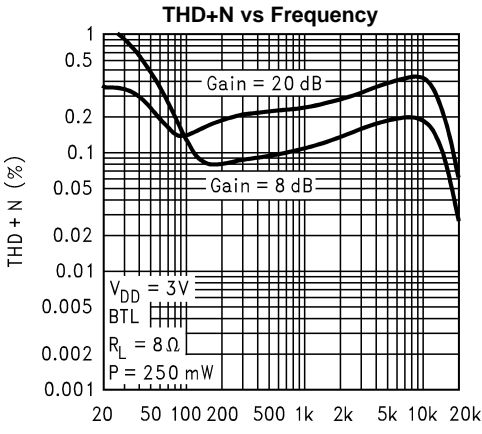

Figure 10.

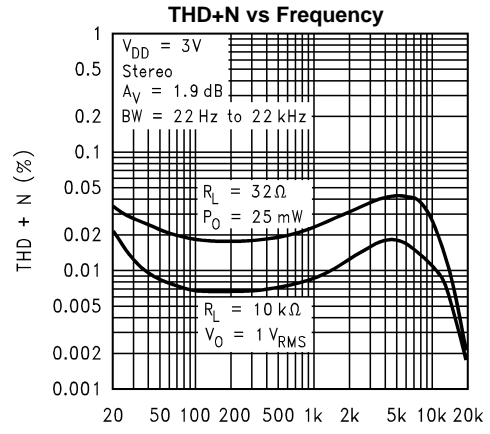

Figure 11.

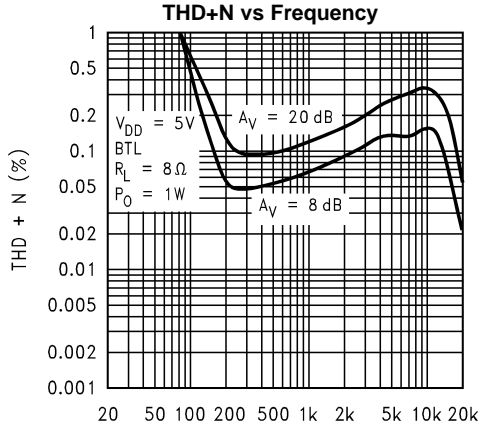

Figure 12.

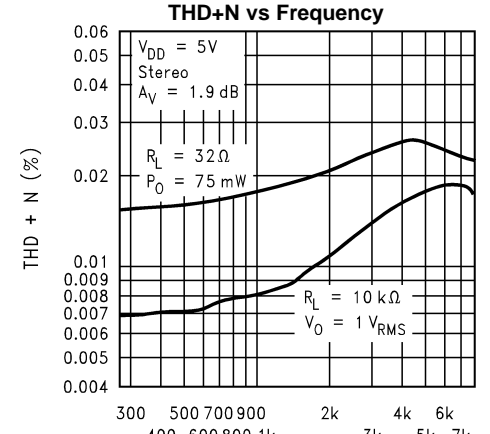

Figure 13.

Typical Performance Characteristics (continued)

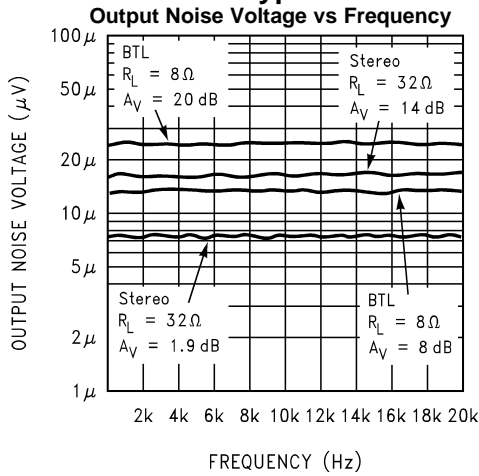

Figure 14.

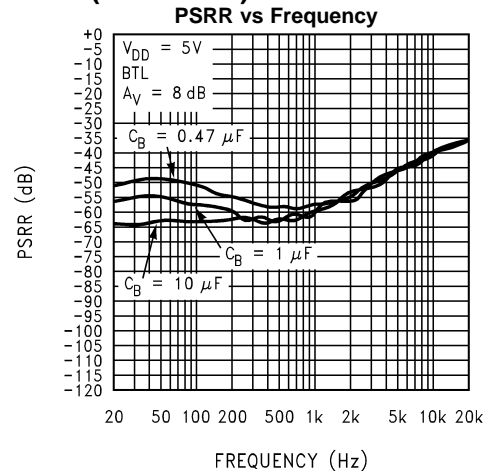

Figure 15.

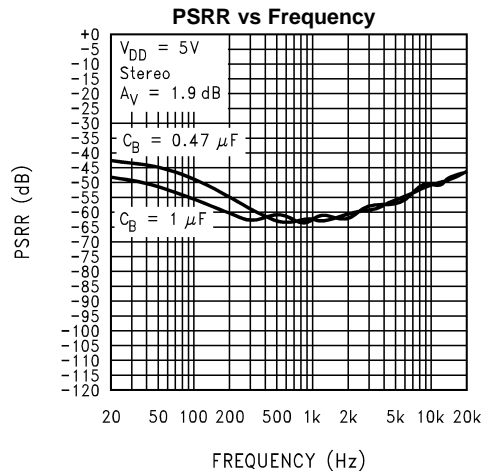

Figure 16.

APPLICATION INFORMATION

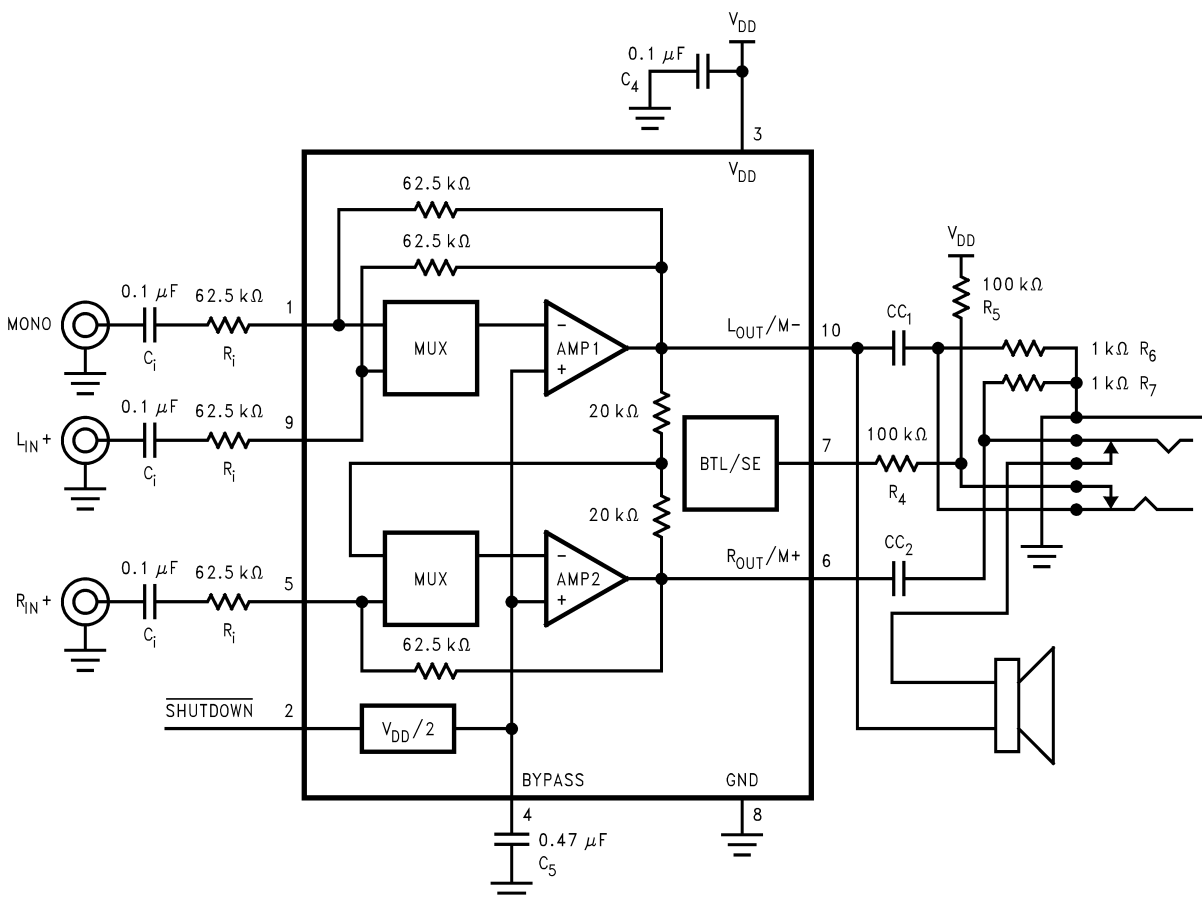

Figure 17. Typical Audio Amplifier Application Circuit

Bridge (BTL) OR Single-Ended (SE) Configuration Explanation

As shown in Figure 17, the LM4913 consists of two input multiplexers (MUX) and two power amplifiers designed to drive loads that have a minimum impedance of 4 ohms. In mono BTL mode, AMP1 and AMP2 drive a speaker connected between their outputs. In stereo SE mode, AMP1 and AMP2 each drive a SE load such as stereo headphones.

In mono BTL mode, R1 works with one of AMP1's internal 62.5Ω feedback resistors to set this amplifier's gain. AMP2 operates unity gain, set by two internal 20kΩ resistors. In stereo SE modes, R2 and R3 work with AMP1's and AMP2's internal 62.5kΩ feedback resistors to set each amplifier's gain. The LM4913 drives a BTL load, such as a speaker, connected between AMP1's and AMP2's outputs. Two SE loads can also be connected to the LM4913's outputs, one driven by AMP1 and the other driven by AMP2.

When the LM4913 operates in BTL mode, AMP1's output serves as AMP2's input through AMP2's input MUX. This results in AMP1 and AMP2 producing signals identical in magnitude, but 180° out of phase. Taking advantage of this phase difference, a load placed between ROUT/M+ and LOUT/M- is driven differentially (commonly referred to as "bridge mode"). This results in a differential, or BTL, gain of

$$A_v (\text{BTL}) = -2(A_v(\text{SE})) \quad (1)$$

$$A_v (\text{SE}) = -2(62.5\text{k}\Omega) / R_i \quad (2)$$

$$A_v (\text{BTL}) = -125\text{k}\Omega / R_i \quad (3)$$

Bridge mode amplifiers are different from single-ended amplifiers that drive loads connected between a single amplifier's output and ground. At any given supply voltage, bridge mode has a distinct advantage over the single-ended configuration: its differential output doubles the voltage swing across the load. Theoretically, this produces four times the output power when compared to a single-ended, capacitively coupled amplifier under the same conditions. This increase in attainable output power assumes that an amplifier is not current limited and that the output signal is not clipped. To ensure minimum output signal clipping when choosing an amplifier's closed-loop gain, refer to the [Audio Power Amplifier Design](#) section.

Power Dissipation

Power dissipation is a major concern when designing a successful single-ended or bridged amplifier. [Equation 4](#) states the maximum power dissipation point for a single-ended amplifier operating at a given supply voltage and driving a specified output load.

$$P_{\text{DMAX-SE}} = (V_{\text{DD}})^2 / 2\pi^2 R_L: \text{ Single-Ended} \quad (4)$$

However, a direct consequence of the increased power delivered to the load by a bridge amplifier is higher internal power dissipation for the same conditions. The LM4913 has two operational amplifiers driving a mono bridge load. The maximum internal power dissipation operating in the bridge mode is twice that of a single-ended amplifier. From [Equation 5](#), assuming a 5V power supply and an 8Ω load, the maximum BTL-mode power dissipation is 317mW.

$$P_{\text{DMAX-MONOBTL}} = 2(V_{\text{DD}})^2 / 2\pi^2 R_L: \text{ Bridge Mode} \quad (5)$$

The maximum power dissipation point given by [Equation 5](#) must not exceed the power dissipation given by [Equation 6](#):

$$P_{\text{DMAX}} = (T_{\text{JMAX}} - T_A) / \theta_{\text{JA}} \quad (6)$$

The LM4913's $T_{\text{JMAX}} = 150^\circ\text{C}$. In the DGQ package, the LM4913's θ_{JA} is 46°C/W . At any given ambient temperature T_A , use [Equation 6](#) to find the maximum internal power dissipation supported by the IC packaging. Rearranging [Equation 6](#) and substituting P_{DMAX} for P_{DMAX} results in [Equation 7](#). This equation gives the maximum ambient temperature that still allows maximum mono BTL power dissipation without violating the LM4913's maximum junction temperature.

$$T_A = T_{\text{JMAX}} - P_{\text{DMAX-MONOBTL}} \theta_{\text{JA}} \quad (7)$$

For a typical application with a 5V power supply and an 8Ω load, the maximum ambient temperature that allows maximum BTL power dissipation without exceeding the maximum junction temperature is approximately 134°C for the IBL package.

$$T_{\text{JMAX}} = P_{\text{DMAX-MONOBTL}} \theta_{\text{JA}} + T_A \quad (8)$$

[Equation 8](#) gives the maximum junction temperature T_{JMAX} . If the result violates the LM4913's 150°C T_{JMAX} , reduce the maximum junction temperature by decreasing the power supply voltage or increasing the load resistance. Further allowance should be made for increased ambient temperatures.

The above examples assume that a device is a surface mount part operating around the maximum power dissipation point. Since internal power dissipation is a function of output power, higher ambient temperatures are allowed as output power or duty cycle decreases. If the result of [Equation 5](#) is greater than that of [Equation 6](#), then decrease the supply voltage, increase the load impedance, or reduce the ambient temperature. If these measures are insufficient, a heat sink can be added to reduce θ_{JA} . The heat sink can be created using additional copper area around the package, with connections to the ground pin(s), supply pin and amplifier output pins. External, solder attached SMT heatsinks such as the Thermalloy 7106D can also improve power dissipation. When adding a heat sink, the θ_{JA} is the sum of θ_{JC} , θ_{CS} , and θ_{SA} . (θ_{JC} is the junction-to-case thermal impedance, θ_{CS} is the case-to-sink thermal impedance, and θ_{SA} is the sink-to-ambient thermal impedance.) Refer to the [Typical Performance Characteristics](#) curves for power dissipation information at lower output power levels.

Exposed-DAP Package PCB Mounting Considerations

The LM4913's exposed-DAP (die attach paddle) package provides a low thermal resistance between the die and the PCB to which the part is mounted and soldered. This low thermal resistance is achieved by soldering the DAP to a copper pad on the PCB. The copper pad's dimensions should match the DAP's. The copper pad should then connect to a larger copper area. This area can be on the component side, in an inner layer in a multi-layer board, or on the board's back side. This connection from the DAP, to the DAP pad, and finally to a larger copper area allows rapid heat transfer away from the die to the surrounding air. The result is a low voltage audio power amplifier that produces 2.0W at $\approx 1\%$ THD+N with a 4 Ω load. This high power is achieved through careful consideration of necessary thermal design. Failing to optimize thermal design may compromise the LM4913's high power performance and activate unwanted, though necessary, thermal shutdown protection.

The DGQ package must have its DAP soldered to a copper pad on the PCB. The DAP's PCB copper pad is connected to a large plane of continuous unbroken copper. This plane forms a thermal mass, and heat sink, and radiation area. Place the heat sink area on either outside plane in the case of a two-sided PCB, or on an inner layer of a board with more than two layers. Connecting to a ground plane is permissible. Connect the DAP copper pad to the inner layer or backside copper heat sink area with 4(2x2) vias. The via diameter should be 0.012in-0.013in with a 1.27mm pitch. Ensure efficient thermal conductivity by plating-through and solder-filling the vias.

Best thermal performance is achieved with the largest practical copper heatsink area. If the heatsink and amplifier share the same PCB layer, a nominal 2.5in² (min) area is necessary for 5V operation with a 4 Ω load. The heatsink area should be 5in² (min) when placed on a layer different from that used by the LM4913. The last two area recommendations apply for 25°C ambient temperature. Increase the area to compensate for ambient temperatures above 25°C. In all circumstances and conditions, the junction temperature must be held below 150°C to prevent activating the LM4913's thermal shutdown protection. The LM4913's power de-rating curve in the Typical Performance Characteristics shows the maximum power dissipation versus temperature. An example PCB layout for the LM4913's exposed-DAP package is shown in the [LM4913 Demo Board Artwork](#) section.

PCB Layout and Supply Regulation Considerations for Driving 4 Ω Loads

Power dissipated by a load is a function of the voltage swing across the load and the load's impedance. As load impedance decreases, load dissipation becomes increasingly dependent on the interconnect (PCB trace and wire) resistance between the amplifier output pins and the load's connections. Residual trace resistance causes a voltage drop, which results in power dissipated in the trace and not in the load as desired. For example, 0.1 Ω trace resistance reduces the output power dissipated by a 4 Ω load from 2W to 1.9W. This problem of decreased load dissipation is exacerbated as load impedance decreases. Therefore, to maintain the highest load dissipation and widest output voltage swing, PCB traces that connect the output pins to a load must be as wide as possible.

Poor power supply regulation adversely affects maximum output power. A poorly regulated supply's output voltage decreases with increasing load current. Reduced supply voltage causes decreased headroom, output signal clipping, and reduced output power. Even with tightly regulated supplies, trace resistance creates the same effects as poor supply regulation. Therefore, make the power supply traces as wide as possible to maintain full output voltage swing.

Power Supply Bypassing

As with any power amplifier, proper supply bypassing is critical for low noise performance and high power supply rejection. Applications that employ a 5V regulator typically use a 10 μ F in parallel with a 0.1 μ F filter capacitors to stabilize the regulator's output, reduce noise on the supply line, and improve the supply's transient response. However, their presence does not eliminate the need for a local 0.47 μ F tantalum bypass capacitance connected between the LM4913's supply pins and ground. Do not substitute a ceramic capacitor for the tantalum. Doing so may cause oscillation.

Keep the length of leads and traces that connect capacitors between the LM4913's power supply pin and ground as short as possible. Connecting a 0.47 μ F capacitor, C_B , between the BYPASS pin and ground improves the internal bias voltage's stability and improves the amplifier's PSRR. The PSRR improvements increase as the bypass pin capacitor value increases. Too large, however, increases turn-on time and can compromise the amplifier's click and pop performance. The selection of bypass capacitor values, especially C_B , depends on desired PSRR requirements, click and pop performance (as explained in the section, [Selecting External Components](#)), system cost, and size constraints.

Micro-Power Shutdown

The LM4913 features an active-low micro-power shutdown mode. When active, the LM4913's micro-power shutdown feature turns off the amplifier's bias circuitry, reducing the supply current. The logic threshold is typically $V_{DD}/2$. The low 0.1 μ A typical shutdown current is achieved by applying a voltage to the SHUTDOWN pin that is as near to GND as possible. A voltage that is greater than GND may increase the shutdown current.

There are a few methods to control the micro-power shutdown. These include using a single-pole, single-throw switch (SPST), a microprocessor, or a microcontroller. When using a switch, connect a 100k Ω pull-up resistor between the SHUTDOWN pin and V_{DD} and the SPST switch between the SHUTDOWN pin and GND. Select normal amplifier operation by opening the switch. Closing the switch applies GND to the SHUTDOWN pin, activating micro-power shutdown. The switch and resistor ensure that the SHUTDOWN pin will not float. This prevents unwanted state changes. In a system with a microprocessor or a microcontroller, use a digital output to apply the active-state voltage to the SHUTDOWN pin.

Headphone (Single-Ended) Amplifier Operation

BTL/SE [Mono (BTL)/Stereo (SE)] Function

Applying a voltage greater than 0.9 V_{DD} to the LM4913's BTL/SE headphone control pin switches the amplifier's operation from mono BTL to stereo SE. Applying a voltage less than 0.55 V_{DD} to the LM4913's BTL/SE headphone control pin switches the amplifier's operation from stereo SE to mono BTL.

Figure 18 shows how to control the LM4913's headphone function using four external resistors and a dual-switch stereo headphone jack. External resistors R4 - R6 provide the control voltages that are applied through the upper headphone jack switch. R6 and R7 provide a DC return path for the SE coupling capacitors.

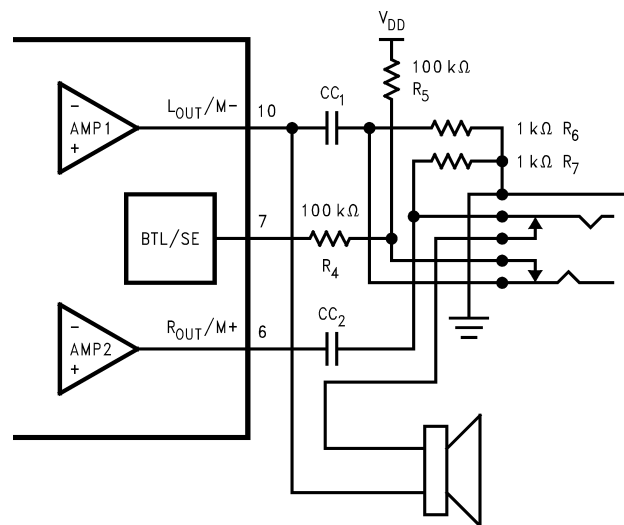

Figure 18. Headphone Operation and BTL - SE Mode Switching

With no headphones connected to the headphone jack, the R5-R6 voltage divider sets the voltage applied to the BTL/SE pin (pin 7) at approximately 50mV (comfortably below the 0.55 V_{DD} logic-low threshold). This 50mV tells the LM4913 to select the signal applied to the MONO-IN input and places the LM4913 in mono BTL operation. When stereo SE operation is desired, both headphone jack switches are opened with a headphone plug. Opening the lower one, allows R5 to apply V_{DD} to the BTL/SE pin. This switches the amplifier's inputs to the stereo signal. Opening the lower one breaks the connection between AMP4's output and the BTL speaker, muting it. The output coupling capacitors blocks the amplifier's half supply DC voltage, protecting the headphones from the $V_{DD}/2$ DC output voltage.

Figure 18 also shows the suggested headphone jack electrical connections. The jack is designed to mate with a three-wire plug. The plug's tip and adjacent ring should carry the left and right channel stereo signals, respectively. The sleeve furthest from the tip should carry the ground return. The Switchcraft 35RAPC4BH3 five-terminal headphone jack easily satisfies the LM4913's requirement for a dual switch headphone jack. For applications that require an SPDIF interface in the stereo headphone jack, use a Foxconn 2F1138-TJ-TR.

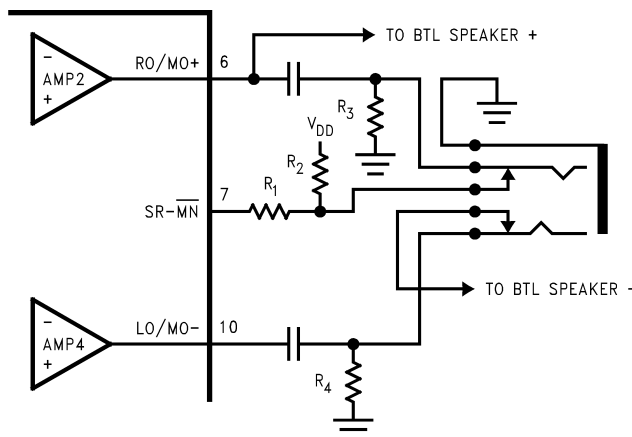

Figure 19. Headphone Circuit

Selecting External Components

Input Capacitor Value Selection

Amplifying the lowest audio frequencies requires high value input coupling capacitor (C_i in Figure 17). A high value capacitor can be expensive and may compromise space efficiency in portable designs. In many cases, however, the speakers used in portable systems, whether internal or external, have little ability to reproduce signals below 150Hz. Applications using speakers with this limited frequency response reap little improvement by using large input capacitor.

The LM4913's advanced output transient suppression circuitry has eliminated the need to select the input capacitor's value in relation to the BYPASS capacitor's value as was necessary in some previous Boomer amplifiers. The value of C_i is now strictly determined by the desired low frequency response.

As shown in Figure 17, the input resistor (R_i) and the input capacitor (C_i) produce a high pass filter cutoff frequency that is found using Equation 9.

$$f_c = 1 / 2\pi R_i C_i \quad (9)$$

As an example when using a speaker with a low frequency limit of 150Hz, C_i , using Equation 9 is 0.063 μ F. The 1.0 μ F C_i shown in Figure 17 allows the LM4913 to drive high efficiency, full range speaker whose response extends below 30Hz.

Bypass Capacitor Value Selection

Besides minimizing the input capacitor size, careful consideration should be paid to value of C_B , the capacitor connected to the BYPASS pin. Since C_B determines how fast the LM4913 settles to quiescent operation, its value is critical when minimizing turn-on pops. The slower the LM4913's outputs ramp to their quiescent DC voltage (nominally $V_{DD}/2$), the smaller the turn-on pop. Choosing C_B equal to 1.0 μ F along with a small value of C_i (in the range of 0.1 μ F to 0.39 μ F), produces a click-less and pop-less shutdown function. As discussed above, choosing C_i no larger than necessary for the desired bandwidth helps minimize clicks and pops. C_B 's value should be in the range of 5 times to 7 times the value of C_i . This ensures that output transients are eliminated when power is first applied or the LM4913 resumes operation after shutdown.

Optimizing Click and Pop Reduction Performance

The LM4913 contains circuitry that eliminates turn-on and shutdown transients ("clicks and pops") and transients that could occur when switching between BTL speakers and single-ended headphones. For this discussion, turn-on refers to either applying the power supply voltage or when the micro-power shutdown mode is deactivated.

As the $V_{DD}/2$ voltage present at the BYPASS pin ramps to its final value, the LM4913's internal amplifiers are configured as unity gain buffers and are disconnected from the RO/MO+ and LO/MO- pins. An internal current source charges the capacitor connected between the BYPASS pin and GND in a controlled, linear manner. Ideally, the input and outputs track the voltage applied to the BYPASS pin. The gain of the internal amplifiers remains unity until the voltage on the bypass pin reaches $V_{DD}/2$. As soon as the voltage on the bypass pin is stable, the device becomes fully operational and the amplifier outputs are reconnected to their respective output pins. Although the BYPASS pin current cannot be modified, changing the size of C_B alters the device's turn-on time. There is a linear relationship between the size of C_B and the turn-on time. Here are some typical turn-on times for various values of C_B :

C_B (μ F)	T_{ON} (ms)
0.01	2
0.1	20
0.22	42
0.47	90
1.0	200
2.2	420

In order to eliminate "clicks and pops", all capacitors must be discharged before turn-on. Rapidly switching V_{DD} may not allow the capacitors to fully discharge, which may cause "clicks and pops".

Audio Power Amplifier Design

Audio Amplifier Design: Driving 1W into an 8 Ω Load

Given:	
Power Output	1 Wrms
Load Impedance	8 Ω
Input Level	1 Vrms
Input Impedance	>20k Ω
Bandwidth	100Hz – 20kHz \pm 0.25 dB

The design begins by specifying the minimum supply voltage necessary to obtain the specified output power. One way to find the minimum supply voltage is to use the Output Power vs Supply Voltage curve in the [Typical Performance Characteristics](#) section. Another way, using [Equation 10](#), is to calculate the peak output voltage necessary to achieve the desired output power for a given load impedance. To account for the amplifier's dropout voltage, two additional voltages, based on the Dropout Voltage vs Supply Voltage in the [Typical Performance Characteristics](#) curves, must be added to the result obtained by [Equation 10](#). The result is [Equation 11](#).

$$V_{\text{opeak}} = \sqrt{2R_L P_O} \quad (10)$$

$$V_{DD} = V_{\text{OUTPEAK}} + V_{\text{ODTOP}} + V_{\text{ODBOT}} \quad (11)$$

The Output Power vs. Supply Voltage graph for an 8 Ω load indicates a minimum supply voltage of 4.6V. The commonly used 5V supply voltage easily meets this. The additional voltage creates the benefit of headroom, allowing the LM4913 to produce peak output power in excess of 1W without clipping or other audible distortion. The choice of supply voltage must also not create a situation that violates of maximum power dissipation as explained above in the [Power Dissipation](#) section.

After satisfying the LM4913's power dissipation requirements, the minimum differential gain needed to achieve 1W dissipation in an 8 Ω load is found using [Equation 12](#). (RESUME HERE- All that is left is to discuss the BTL low frequency phase shift.)

$$A_V (\text{BTL}) \geq \frac{\sqrt{P_O R_L}}{V_{IN}} = \frac{V_{ORMS}}{V_{INRMS}} \quad (12)$$

Thus, a minimum gain of 2.83 allows the LM4913's to reach full output swing and maintain low noise and THD+N performance. For this example, let $A_V(\text{BTL}) = 3$. The amplifier's overall gain is set using the input (R_i), the first stage internal feedback resistor, and the second stage's fixed gain of 1.25. With the desired input impedance set at 20k Ω , the feedback resistor is found using [Equation 13](#).

LM4913

SNAS202F – DECEMBER 2002 – REVISED APRIL 2013

www.ti.com

$$R_i = -125\text{k}\Omega / A_V \text{ (BTL)} \quad (13)$$

The value of R_i is 44.2k Ω . The nominal output power is 1.13W.

The last step in this design example is setting the amplifier's -3dB frequency bandwidth. To achieve the desired $\pm 0.25\text{dB}$ pass band magnitude variation limit, the low frequency response must extend to at least one-fifth the lower bandwidth limit and the high frequency response must extend to at least five times the upper bandwidth limit. The gain variation for both response limits is 0.17dB, well within the $\pm 0.25\text{dB}$ desired limit. The results are an

$$f_L = 100\text{Hz} / 5 = 20\text{Hz} \quad (14)$$

and an

$$f_H = 20\text{kHz} \times 5 = 100\text{kHz} \quad (15)$$

As mentioned in the [Selecting External Components](#) section, R_i and C_i create a highpass filter that sets the amplifier's lower bandpass frequency limit. Find the coupling capacitor's value using [Equation 16](#).

$$C_i = 1 / 2\pi R_i f_L \quad (16)$$

The result is

$$1 / 2\pi \times 44.2\text{k}\Omega \times 20\text{Hz} = 0.180\mu\text{F} \quad (17)$$

Use a 180 μF capacitor, the closest standard value.

The product of the desired high frequency cutoff (100kHz in this example) and the differential gain $A_V(\text{BTL})$, determines the upper passband response limit. With $A_V(\text{BTL}) = 3$ and $f_H = 100\text{kHz}$, the closed-loop gain bandwidth product (GBWP) is 300kHz. This is less than the LM4913's 3.5MHz GBWP. With this margin, the amplifier can be used in designs that require more differential gain while avoiding performance restricting bandwidth limitations.

LM4913 Demo Board Artwork

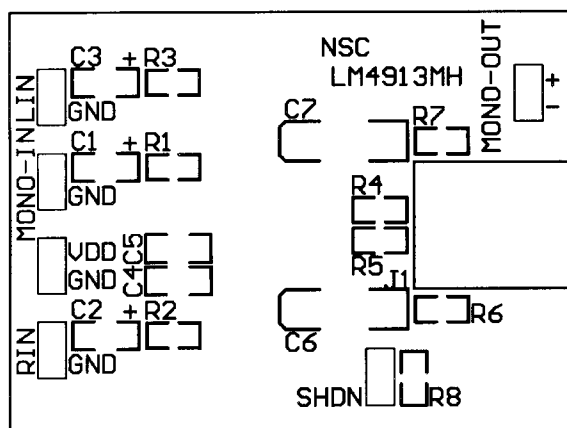

Figure 20. Top Overlay

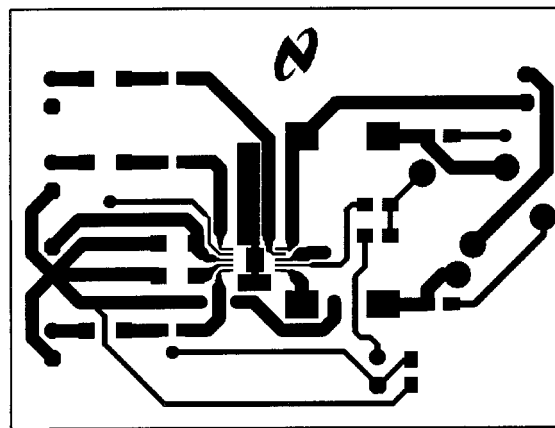

Figure 21. Top Layer

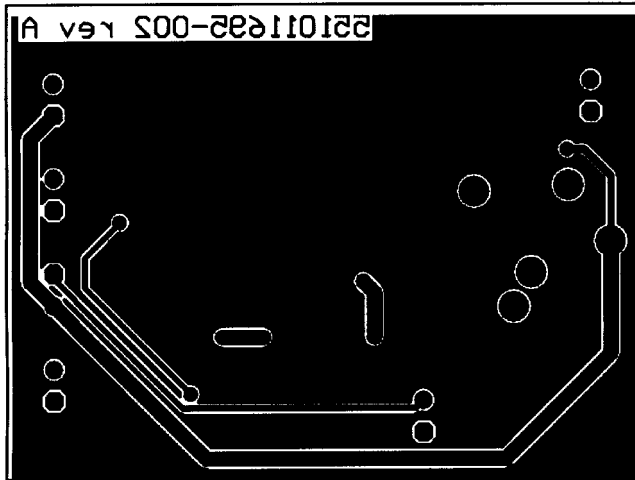

Figure 22. Bottom Layer

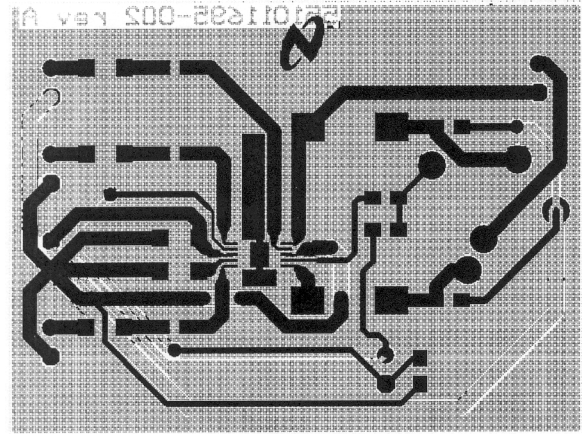

Figure 23. Composite Layer

Revision History

Rev	Date	Description
1.0	8/05/05	Replaced the mktg outline (MUA08A, wrong one) (with the correct one (MXF10A) per Allan, then re-released D/S to the WEB.
1.1	7/25/06	Did a minor edit on the conn. dg, RO/MO- to RO/MO+ (per Allan S.), then re-released the D/S to the WEB.
1.2	04/21/08	Re-arranged the Typical Performance Characteristics curves.
F	04/10/13	Changed layout of National Data Sheet to TI format.

IMPORTANT NOTICE

Texas Instruments Incorporated and its subsidiaries (TI) reserve the right to make corrections, enhancements, improvements and other changes to its semiconductor products and services per JESD46, latest issue, and to discontinue any product or service per JESD48, latest issue. Buyers should obtain the latest relevant information before placing orders and should verify that such information is current and complete. All semiconductor products (also referred to herein as "components") are sold subject to TI's terms and conditions of sale supplied at the time of order acknowledgment.

TI warrants performance of its components to the specifications applicable at the time of sale, in accordance with the warranty in TI's terms and conditions of sale of semiconductor products. Testing and other quality control techniques are used to the extent TI deems necessary to support this warranty. Except where mandated by applicable law, testing of all parameters of each component is not necessarily performed.

TI assumes no liability for applications assistance or the design of Buyers' products. Buyers are responsible for their products and applications using TI components. To minimize the risks associated with Buyers' products and applications, Buyers should provide adequate design and operating safeguards.

TI does not warrant or represent that any license, either express or implied, is granted under any patent right, copyright, mask work right, or other intellectual property right relating to any combination, machine, or process in which TI components or services are used. Information published by TI regarding third-party products or services does not constitute a license to use such products or services or a warranty or endorsement thereof. Use of such information may require a license from a third party under the patents or other intellectual property of the third party, or a license from TI under the patents or other intellectual property of TI.

Reproduction of significant portions of TI information in TI data books or data sheets is permissible only if reproduction is without alteration and is accompanied by all associated warranties, conditions, limitations, and notices. TI is not responsible or liable for such altered documentation. Information of third parties may be subject to additional restrictions.

Resale of TI components or services with statements different from or beyond the parameters stated by TI for that component or service voids all express and any implied warranties for the associated TI component or service and is an unfair and deceptive business practice. TI is not responsible or liable for any such statements.

Buyer acknowledges and agrees that it is solely responsible for compliance with all legal, regulatory and safety-related requirements concerning its products, and any use of TI components in its applications, notwithstanding any applications-related information or support that may be provided by TI. Buyer represents and agrees that it has all the necessary expertise to create and implement safeguards which anticipate dangerous consequences of failures, monitor failures and their consequences, lessen the likelihood of failures that might cause harm and take appropriate remedial actions. Buyer will fully indemnify TI and its representatives against any damages arising out of the use of any TI components in safety-critical applications.

In some cases, TI components may be promoted specifically to facilitate safety-related applications. With such components, TI's goal is to help enable customers to design and create their own end-product solutions that meet applicable functional safety standards and requirements. Nonetheless, such components are subject to these terms.

No TI components are authorized for use in FDA Class III (or similar life-critical medical equipment) unless authorized officers of the parties have executed a special agreement specifically governing such use.

Only those TI components which TI has specifically designated as military grade or "enhanced plastic" are designed and intended for use in military/aerospace applications or environments. Buyer acknowledges and agrees that any military or aerospace use of TI components which have **not** been so designated is solely at the Buyer's risk, and that Buyer is solely responsible for compliance with all legal and regulatory requirements in connection with such use.

TI has specifically designated certain components as meeting ISO/TS16949 requirements, mainly for automotive use. In any case of use of non-designated products, TI will not be responsible for any failure to meet ISO/TS16949.

Products

Audio	www.ti.com/audio
Amplifiers	amplifier.ti.com
Data Converters	dataconverter.ti.com
DLP® Products	www.dlp.com
DSP	dsp.ti.com
Clocks and Timers	www.ti.com/clocks
Interface	interface.ti.com
Logic	logic.ti.com
Power Mgmt	power.ti.com
Microcontrollers	microcontroller.ti.com
RFID	www.ti-rfid.com
OMAP Applications Processors	www.ti.com/omap
Wireless Connectivity	www.ti.com/wirelessconnectivity

Applications

Automotive and Transportation	www.ti.com/automotive
Communications and Telecom	www.ti.com/communications
Computers and Peripherals	www.ti.com/computers
Consumer Electronics	www.ti.com/consumer-apps
Energy and Lighting	www.ti.com/energy
Industrial	www.ti.com/industrial
Medical	www.ti.com/medical
Security	www.ti.com/security
Space, Avionics and Defense	www.ti.com/space-avionics-defense
Video and Imaging	www.ti.com/video

TI E2E Community

e2e.ti.com

Looking for pricing, stock, or lifecycle information?

Click below to explore more details on WIN SOURCE:

 [View LM4913MH/NOPB on WIN SOURCE](#)

 [Texas Instruments](#) Information

Optimize Your Supply Chain with WIN SOURCE Solutions

-  Global Sourcing Solution
-  Obsolete Management
-  Cost Control Management
-  Shortage Management
-  Alternative Solution
-  Excess Inventory Management