



THE DATASHEET OF LM48557TLX



LM48557 Boomer™ Mono, Bridge-Tied Load, Ceramic Speaker Driver with I²C Volume Control and Reset

Check for Samples: [LM48557](#)

FEATURES

- Integrated Charge Pump
- Bridge-Tied Load Output
- Differential Input
- High PSRR
- I²C Volume and Mode Control
- Reset Input
- Advanced Click-and-Pop Suppression
- Low Supply Current
- Minimum External Components
- Micro-Power Shutdown
- Available in Space-Saving 16-Bump DSBGA Package

APPLICATIONS

- Mobile Phones
- PDAs
- Notebook Electronic Devices
- MP3 Players

KEY APPLICATIONS

- Output Voltage at $V_{DD} = 4.2V$
 - $R_L = 1\mu F + 22\Omega$, THD+N $\leq 1\%$: 5.8 V_{RMS} (Typ)

DESCRIPTION

The LM48557 is a single supply, mono, ceramic speaker driver with an integrated charge-pump, designed for portable devices, such as cell phones and portable media players, where board space is at a premium. The LM48557 charge pump allows the device to deliver 5.8V_{RMS} from a single 4.2V supply.

The LM48557 features high power supply rejection ratio (PSRR), 80dB at 217Hz, allowing the device to operate in noisy environments without additional power supply conditioning. Flexible power supply requirements allow operation from 2.7V to 4.5V. The LM48557 features an active low reset input that reverts the device to its default state. Additionally, the LM48557 features a 36-step I²C volume control and mute function. The low power Shutdown mode reduces supply current consumption to 0.01 μ A.

The LM48557's superior click and pop suppression eliminates audible transients on power-up/down and during shutdown. The LM48557 is available in an ultra-small 16-bump DSBGA package (1.965mm x 1.965mm).



Please be aware that an important notice concerning availability, standard warranty, and use in critical applications of Texas Instruments semiconductor products and disclaimers thereto appears at the end of this data sheet.

Boomer is a trademark of Texas Instruments.

All other trademarks are the property of their respective owners.

Typical Application

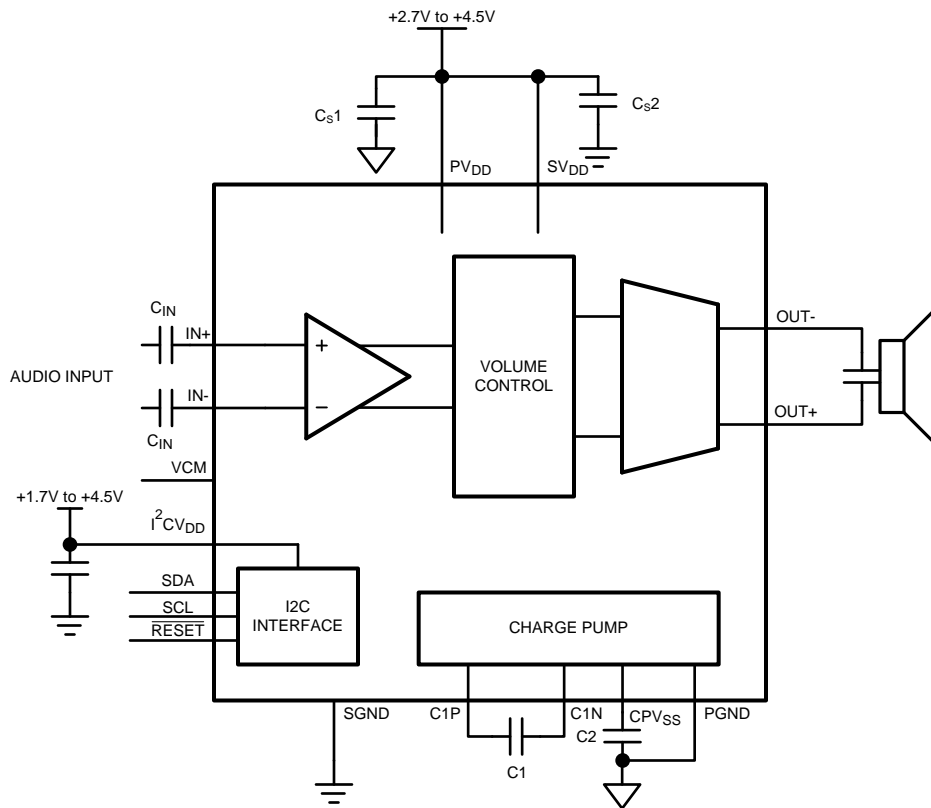

Figure 1. Typical Audio Amplifier Application Circuit

Connection Diagram

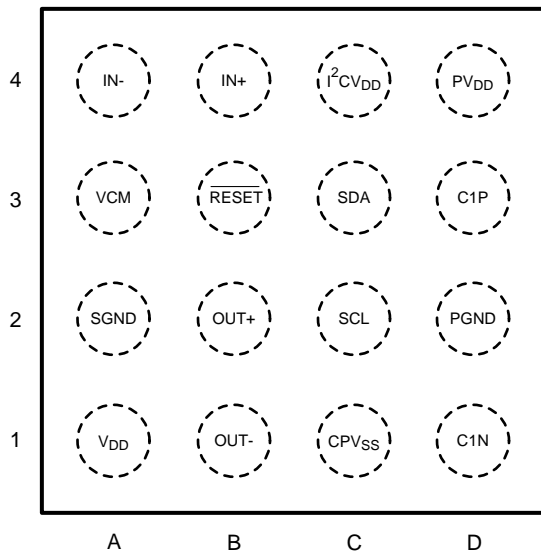

Figure 2. YZR Package - Top View
See Package Number YZR001611A

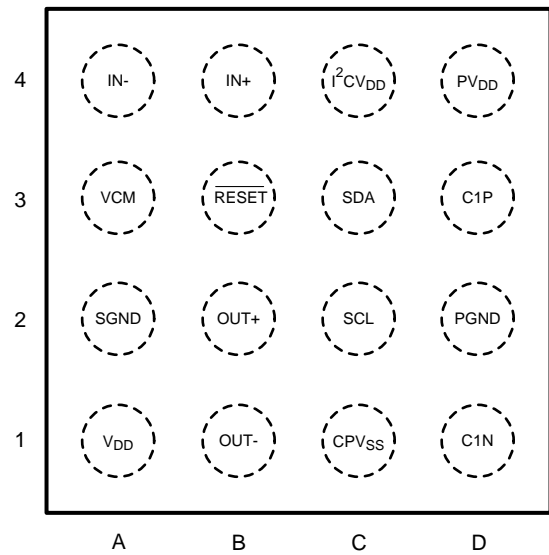

Figure 3. YPD Package - Top View
See Package Number YPD001611A

Table 1. Bump Descriptions

Bump	Name	Description
A1	SV _{DD}	Signal Power Supply
A2	SGND	Signal Ground
A3	VCM	Common Mode Sense Input
A4	IN-	Amplifier Inverting input
B1	OUT-	Amplifier Inverting output
B2	OUT+	Amplifier Non-Inverting Output
B3	$\overline{\text{RESET}}$	Active Low Reset Input. Connect to V _{DD} for normal operation. Toggle between V _{DD} and GND to reset the device.
B4	IN+	Amplifier Non-Inverting Input
C1	CPV _{SS}	Charge Pump Output
C2	SCL	I ² C Serial Clock Input
C3	SDA	I ² C Serial Data Input
C4	I ² CV _{DD}	I ² C Supply Voltage
D1	C1N	Charge Pump Flying Capacitor Negative Terminal
D2	PGND	Power Ground
D3	C1P	Charge Pump Flying Capacitor Positive Terminal
D4	PV _{DD}	Power Supply



These devices have limited built-in ESD protection. The leads should be shorted together or the device placed in conductive foam during storage or handling to prevent electrostatic damage to the MOS gates.

Absolute Maximum Ratings⁽¹⁾⁽²⁾⁽³⁾

Supply Voltage ⁽¹⁾	5.25V
Storage Temperature	-65°C to +150°C
Input Voltage	-0.3V to V _{DD} +0.3V
Power Dissipation ⁽⁴⁾	Internally Limited
ESD Rating-Human Body Model ⁽⁵⁾	2kV
ESD Rating-Machine Model ⁽⁶⁾	150V
Junction Temperature	150°C
Thermal Resistance	θ_{JA} (typ) - (YZR001611A) 63°C/W
Soldering Information: See AN-1112 "Micro SMD Wafer Level Chip Scale Package."	

- (1) "Absolute Maximum Ratings indicate limits beyond which damage to the device may occur, including inoperability and degradation of device reliability and/or performance. Functional operation of the device and/or non-degradation at the Absolute Maximum Ratings or other conditions beyond those indicated in the Operating Ratings is not implied. The Operating Ratings indicate conditions at which the device is functional and the device should not be operated beyond such conditions. All voltages are measured with respect to the ground pin, unless otherwise specified.
- (2) The Electrical Characteristics tables list specified specifications under the listed Operating Ratings except as otherwise modified or specified by the Electrical Characteristics Conditions and/or Notes. Typical specifications are estimations only and are not ensured.
- (3) If Military/Aerospace specified devices are required, please contact the Texas Instruments Sales Office/Distributors for availability and specifications.
- (4) The maximum power dissipation must be derated at elevated temperatures and is dictated by T_{JMAX}, θ_{JA} , and the ambient temperature, T_A. The maximum allowable power dissipation is P_{DMAX} = (T_{JMAX} - T_A) / θ_{JA} or the number given in Absolute Maximum Ratings, whichever is lower.
- (5) Human body model, applicable std. JESD22-A114C.
- (6) Machine model, applicable std. JESD22-A115-A.

Operating Ratings

Temperature Range (T _{MIN} ≤ T _A ≤ T _{MAX})	-40°C ≤ T _A ≤ +85°C	
Supply Voltage	PV _{DD} and SV _{DD}	2.7V ≤ V _{DD} ≤ 4.5V
	I ² CV _{DD}	1.7V ≤ I ² CV _{DD} ≤ 4.5V

Electrical Characteristics $V_{DD} = 4.2V^{(1)(2)}$

The following specifications apply for $A_V = 6dB$, $R_L = 1\mu F + 22\Omega$, $C_1 = 2.2\mu F$, $C_2 = 2.2\mu F$, $f = 1kHz$, unless otherwise specified. Limits apply for $T_A = 25^\circ C$.

Symbol	Parameter	Conditions	LM48557			Units
			Min ⁽³⁾	Typ ⁽⁴⁾	Max ⁽³⁾	
V_{DD}	Supply Voltage Range		2.7		4.5	V
I^2CV_{DD}	I ² C Supply Voltage Range		1.7		4.5	V
I_{DD}	Quiescent Power Supply Current	$V_{IN} = 0V$, $R_L = \infty$		5	8	mA
I_{SD}	Shutdown Current	Shutdown Enabled		0.01	1	μA
$ V_{OS} $	Differential Output Offset Voltage	$V_{IN} = 0V$, $A_V = 0dB$		3	12	mV
		$V_{IN} = 0V$, $A_V = 48dB$		40	160	mV
V_{IH}	Logic High Input Threshold	\overline{RESET} , $V_{DD} = 2.7V$ to $4.5V$	1.4			V
V_{IL}	Logic Low Input Threshold	\overline{RESET} , $V_{DD} = 2.7V$ to $4.5V$			0.4	V
A_V	Gain	Minimum Gain Setting Volume Control = 000001	-25.5	-25	-24.5	dB
		Maximum Gain Setting Volume Control = 111111	47	48	49	dB
$A_{V(MUTE)}$	Mute Attenuation	Volume Control = 000000		-90		dB
R_{IN}	Input Resistance		1	3		M Ω
V_{IN}	Common Mode Input Voltage Range		-1		1	V_{P-P}
V_O	Output Voltage	$R_L = 1\mu F + 22\Omega$, THD+N = 1%				
		$f = 1kHz$	5.5	5.8		V_{RMS}
		$f = 5kHz$	15.6	16.4		V_{P-P}
		$R_L = 2.2\mu F + 10\Omega$, THD+N = 1%				
		$f = 1kHz$		5.6		V_{RMS}
	$f = 5kHz$		2.9		V_{RMS}	
THD+N	Total Harmonic Distortion + Noise	$V_O = 4V_{RMS}$, $f = 1kHz$, $A_V = 48dB$		0.05		%
PSRR	Power Supply Rejection Ratio (Figure 4)	$V_{DD} = 4.2V + 200mV_{P-P}$ (sine), Inputs AC GND, $C_{IN} = 0.1\mu F$, $A_V = 0dB$				
		$f_{RIPPLE} = 217Hz$		80		dB
		$f_{RIPPLE} = 1kHz$		80		dB
		$V_{DD} = 4.2V + 200mV_{P-P}$ (sine), Inputs AC GND, $C_{IN} = 0.1\mu F$, $A_V = 48dB$				
		$f = 1kHz$	15	40		dB
	$f = 5kHz$		40		dB	
CMRR	Common Mode Rejection Ratio (Figure 5)	$V_{CM} = 200mV_{P-P}$ (sine), $C_{IN} = 0.1\mu F$, $A_V = 48dB$				
		$f_{RIPPLE} = 500Hz$	16	36		dB
		$f_{RIPPLE} = 1kHz$		37		dB
f_{SW}	Charge Pump Switching Frequency		230	300	370	kHz
SNR	Signal To Noise Ratio	$V_{OUT} = 5V_{RMS}$, $f = 1kHz$, $A_V = 48dB$		74		dB
ϵ_{OS}	Output Noise	$A_V = 0dB$, A-Weighted Filter		20	30	μV
		$A_V = 48dB$, A-weighted Filter		1		mV

- (1) "Absolute Maximum Ratings indicate limits beyond which damage to the device may occur, including inoperability and degradation of device reliability and/or performance. Functional operation of the device and/or non-degradation at the Absolute Maximum Ratings or other conditions beyond those indicated in the Operating Ratings is not implied. The Operating Ratings indicate conditions at which the device is functional and the device should not be operated beyond such conditions. All voltages are measured with respect to the ground pin, unless otherwise specified.
- (2) The Electrical Characteristics tables list specified specifications under the listed Operating Ratings except as otherwise modified or specified by the Electrical Characteristics Conditions and/or Notes. Typical specifications are estimations only and are not ensured.
- (3) Datasheet min/max specification limits are specified by test or statistical analysis.
- (4) Typical values represent most likely parametric norms at $T_A = +25^\circ C$, and at the Operation Rating at the time of product characterization and are not ensured.

Electrical Characteristics $V_{DD} = 4.2V^{(1)(2)}$ (continued)

The following specifications apply for $A_V = 6dB$, $R_L = 1\mu F + 22\Omega$, $C1 = 2.2\mu F$, $C2 = 2.2\mu F$, $f = 1kHz$, unless otherwise specified. Limits apply for $T_A = 25^\circ C$.

Symbol	Parameter	Conditions	LM48557			Units
			Min ⁽³⁾	Typ ⁽⁴⁾	Max ⁽³⁾	
T_{WU}	Wake Up Time	From shutdown		5		ms

I²C Interface Characteristics $1.7V \leq I^2CV_{DD} \leq 4.5V$ ⁽¹⁾⁽²⁾

The following specifications apply for $R_{PU} = 1k\Omega$ to I^2CV_{DD} , unless otherwise specified. Limits apply for $T_A = 25^\circ C$.

Symbol	Parameter	Conditions	LM48557			Units
			Min ⁽³⁾	Typ ⁽⁴⁾	Max ⁽³⁾	
V_{IH}	Logic Input High Threshold	SDA, SCL	$0.7 \times I^2CV_{DD}$			V
V_{IL}	Logic Input Low Threshold	SDA, SCL			$0.3 \times I^2CV_{DD}$	V
V_{OL}	Logic Output Low Threshold	SDA, $I_{SDA} = 3.6mA$			0.35	V
I_{OH}	Logic Output High Current	SDA, SCL, $I^2CV_{DD} = 4.5V$			2	μA
	SCL Frequency				400	kHz
6	SDA Setup Time		100			ns
5	SDA Stable Time		0	250	900	ns
1	Start Condition Time		100			ns
7	Stop Condition Time		100			ns

- (1) "Absolute Maximum Ratings indicate limits beyond which damage to the device may occur, including inoperability and degradation of device reliability and/or performance. Functional operation of the device and/or non-degradation at the Absolute Maximum Ratings or other conditions beyond those indicated in the Operating Ratings is not implied. The Operating Ratings indicate conditions at which the device is functional and the device should not be operated beyond such conditions. All voltages are measured with respect to the ground pin, unless otherwise specified.
- (2) The Electrical Characteristics tables list specified specifications under the listed Operating Ratings except as otherwise modified or specified by the Electrical Characteristics Conditions and/or Notes. Typical specifications are estimations only and are not ensured.
- (3) Datasheet min/max specification limits are specified by test or statistical analysis.
- (4) Typical values represent most likely parametric norms at $T_A = +25^\circ C$, and at the Operation Rating at the time of product characterization and are not ensured.

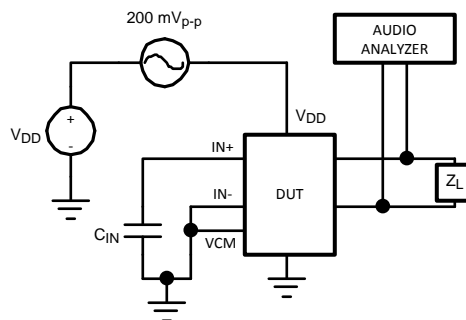

Figure 4. PSRR Test Circuit

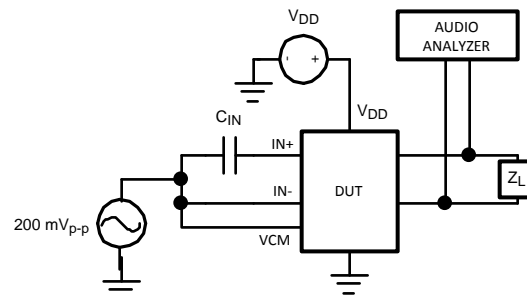

Figure 5. CMRR Test Circuit

Typical Performance Characteristics

THD+N vs Frequency
 $V_{DD} = 3.6V$, $Z_L = 1\mu F + 22\Omega$
 $A_V = 48dB$, $V_O = 2.5V$

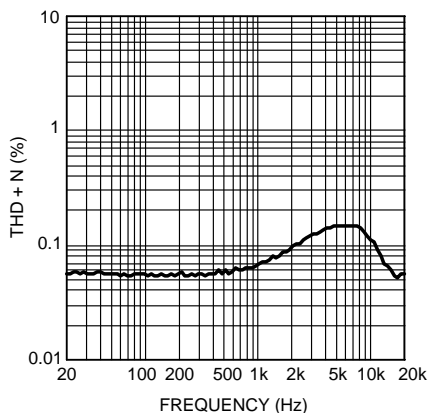

Figure 6.

THD+N vs Frequency
 $V_{DD} = 4.2V$, $Z_L = 1\mu F + 22\Omega$
 $A_V = 48dB$

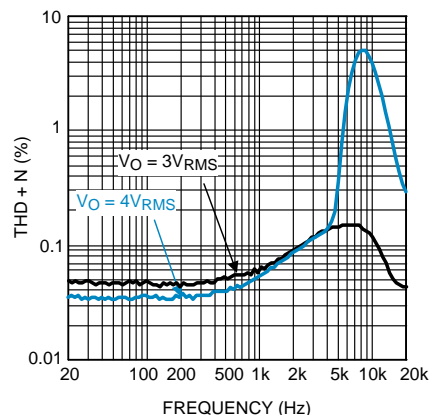

Figure 7.

THD+N vs Output Voltage
 $Z_L = 1\mu F + 22\Omega$, $A_V = 0dB$

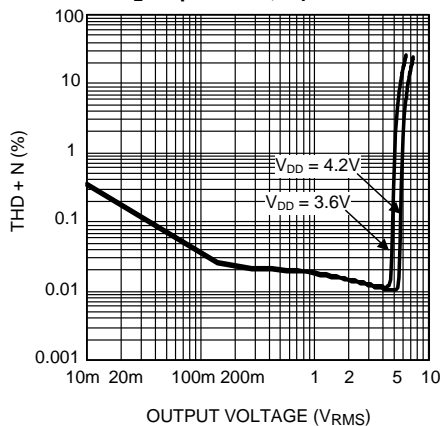

Figure 8.

Output Voltage vs Frequency
 $V_{DD} = 4.2V$, $Z_L = 1\mu F + 22\Omega$
 $THD+N = 1\%$

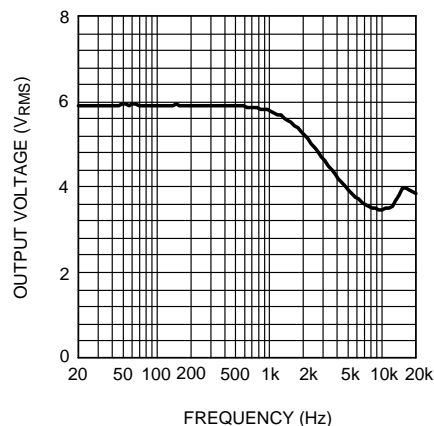

Figure 9.

Power Consumption vs Output Voltage
 $V_{DD} = 3.6V$, $Z_L = 1\mu F + 22\Omega$

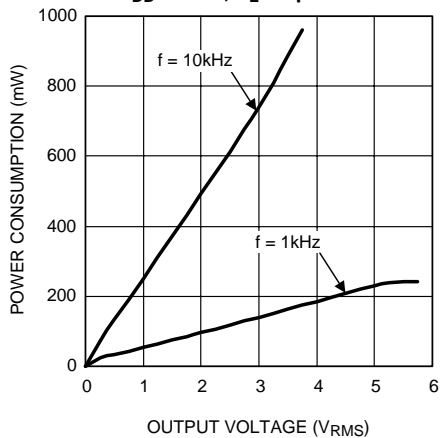

Figure 10.

Power Consumption vs Output Voltage
 $V_{DD} = 4.2V$, $Z_L = 1\mu F + 22\Omega$

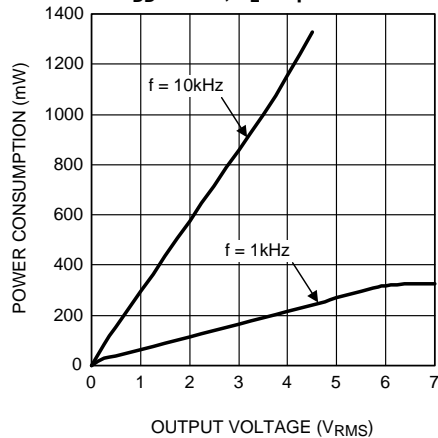

Figure 11.

Typical Performance Characteristics (continued)

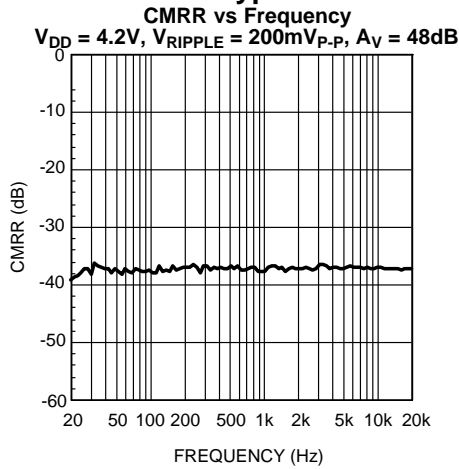

Figure 12.

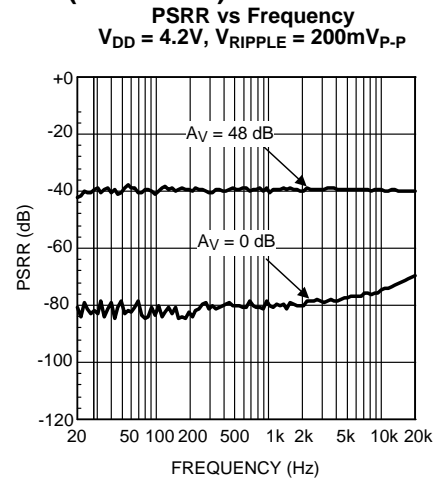

Figure 13.

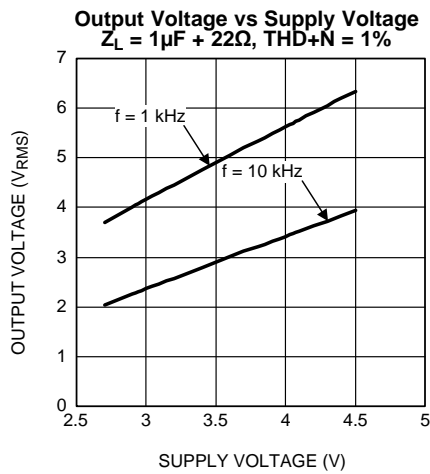

Figure 14.

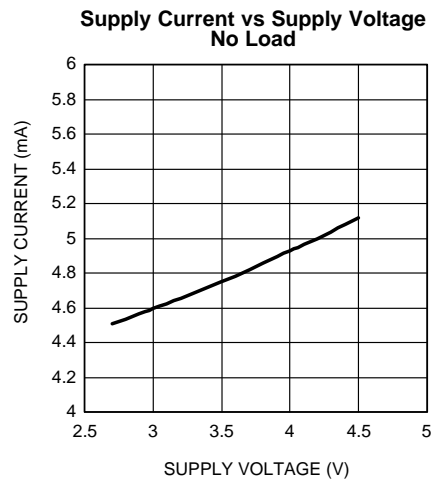

Figure 15.

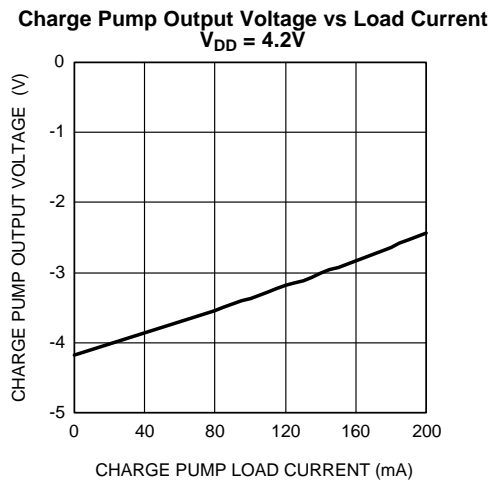

Figure 16.

APPLICATION INFORMATION

I²C COMPATIBLE INTERFACE

The LM48557 is controlled through an I²C compatible serial interface that consists of a serial data line (SDA) and a serial clock (SCL). The clock line is uni-directional. The data line is bi-directional (open drain). The LM48557 and the master can communicate at clock rates up to 400kHz. Figure 17 shows the I²C interface timing diagram. Data on the SDA line must be stable during the HIGH period of SCL. The LM48557 is a transmit/receive slave-only device, reliant upon the master to generate the SCL signal. Each transmission sequence is framed by a START condition and a STOP condition (Figure 18). Each data word, device address and data, transmitted over the bus is 8 bits long and is always followed by an acknowledge pulse (Figure 19). The LM48557 device address is 11011110.

I²C BUS FORMAT

The I²C bus format is shown in Figure 19. The START signal, the transition of SDA from HIGH to LOW while SCL is HIGH, is generated, alerting all devices on the bus that a device address is being written to the bus.

The 7-bit device address is written to the bus, most significant bit (MSB) first, followed by the R/W bit. Set $\overline{R/W} = 0$; the LM48557 is a WRITE-ONLY device and will not respond to $\overline{R/W} = 1$. In other words, the LM48557 will not issue an ACK when $\overline{R/W} = 1$. Each address bit is latched in on the rising edge of the clock. Each address bit must be stable while SCL is HIGH. After the last address bit is transmitted, the master device releases SDA, during which time, an acknowledge clock pulse is generated by the LM48557. If the LM48557 receives the correct address, the device pulls the SDA line low, generating an acknowledge bit (ACK).

Once the master device registers the ACK bit, the 8-bit register data word is sent. Each data bit should be stable while SCL is HIGH. The LM48557 has two registers, Mode Control and Volume Control. The register address and register data are combined into a single byte, the most significant bit (MSB) indicates which register is being addressed. To address the Mode Control register, set the MSB of the data byte to 0, followed by seven bits of register data. To address the Volume Control register, set the MSB of the data byte to 1, followed by seven bits of register data. After the 8-bit register data word is sent, the LM48557 sends another ACK bit. The LM48557 supports single and multi-byte write operations, any number of data bytes can be transmitted to the device between START and STOP conditions. Following the acknowledgement of the last register data word, the master issues a STOP bit, allowing SDA to go high while SCL is high.

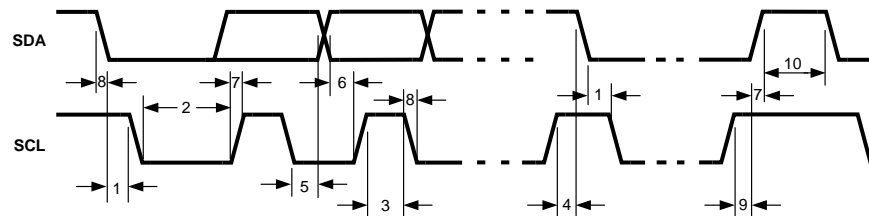

Figure 17. I²C Timing Diagram

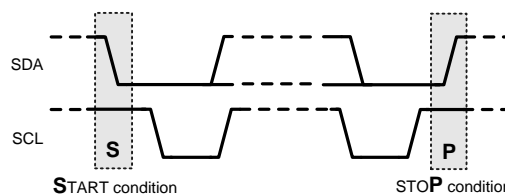

Figure 18. Start and Stop Diagram

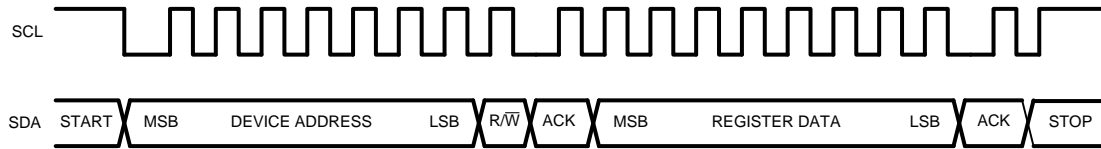

Figure 19. Example Write Sequence

Table 2. Device Address

	B7	B6	B5	B4	B3	B2	B1	B0 R/W
Device Address	1	1	0	1	1	1	1	0

Table 3. Control Registers

Register Name	B7	B6	B5	B4	B3	B2	B1	B0
Mode Control	0	0	0	0	0	0	MUTE	$\overline{\text{SHDN}}$
Volume Control	1	0	VOL5	VOL4	VOL3	VOL2	VOL1	VOL0

Table 4. Mode Control Registers

BIT	NAME	VALUE	DESCRIPTION	DEFAULT SETTING
B0	$\overline{\text{SHDN}}$	0	Shutdown mode	0
		1	Normal operation	
B1	MUTE	0	Normal operation	0
		1	Device mute, $A_V = -90\text{dB}$.	
B2	RESERVED ⁽¹⁾	X	Unused, Set to 0	0
B3	RESERVED ⁽¹⁾	X	Unused, Set to 0	0
B4	TESTMODE	0	Set B4 to 0. B4 = 1 enables TESTMODE. See TEST MODE .	0
B5	RESERVED ⁽¹⁾	X	Unused, Set to 0	0
B6	RESERVED ⁽¹⁾	X	Unused, Set to 0	0
B7	REGISTER ADDRESS	0	Set to 0 to access Mode Control register	0

(1) RESERVED bits are Don't Cares and are ignored by the device. The state of the RESERVED bits does not affect device operation.

Table 5. Volume Control Registers

BIT	NAME	VALUE	DESCRIPTION	DEFAULT SETTING
B0:B5	VOL0:VOL5	See Table 6	Controls amplifier gain/attenuation	0
B6	RESERVED ⁽¹⁾	X	Unused, Set to 0	0
B7	REGISTER ADDRESS	1	Set to 1 to access Volume Control register	1

(1) RESERVED bits are Don't Cares and are ignored by the device. The state of the RESERVED bits does not affect device operation.

SINGLE AND MULTI-BYTE WRITE OPERATION

The LM48557 supports both single-byte and multi-byte write operations. A single-byte write operation begins with the master device transmitting a START condition followed by the device address ([Figure 20](#)). After receiving the correct device address, the LM48557 generates an ACK bit. The master device transmits the register data byte, after which the LM48557 generates an ACK bit. Following the ACK, the master issues a STOP condition, completing the single-byte data transfer.

A multi-byte write operation is similar to a single-byte operation, the master device issues a START condition and device address, and the LM48557 responds with an ACK (Figure 21). The master device then transmits the first data byte. Following the LM48557's ACK, the master device does not issue a STOP condition, transmitting a second data byte instead. The LM48557 responds with an ACK bit. The master device can continue to issue data bytes, and the LM48557 will respond with an ACK, until a STOP condition is issued. Once a STOP condition is issued, the LM48557 ignores the I²C bus until the master issues the LM48557's device address.



Figure 20. Single-Byte Write Example



Figure 21. Multi-Byte Write Example

GENERAL AMPLIFIER FUNCTION

The LM48557 is a fully differential ceramic speaker driver that utilizes Ti's inverting charge pump technology to deliver over 5.8V_{RMS} to a 1µF ceramic speaker while operating from a single 4.2V supply. The low noise, inverting charge pump generates a negative supply voltage (CPV_{SS}) from the positive supply voltage (PV_{DD}). The LM48557 takes advantage of the increased head room created by the charge pump and the bridge-tied load (BTL) architecture, delivering significantly more voltage than a single-ended, single-supply amplifier to the speaker.

Table 6. Volume Control Table

VOLUME STEP	VOL5	VOL4	VOL3	VOL2	VOL1	VOL0	GAIN (dB)
1 (MUTE)	0	0	0	0	0	0	-90
2	0	0	0	0	0	1	-25
3	0	0	0	0	1	0	-22
4	0	0	0	0	1	1	-19
5	0	0	0	1	0	0	-16
6	0	0	0	1	0	1	-13
7	0	0	0	1	1	0	-10
8	0	0	0	1	1	1	-8
9	0	0	1	0	0	0	-6
10	0	0	1	0	0	1	-4
11	0	0	1	0	1	0	-2
12	0	0	1	0	1	1	0
13	0	0	1	1	0	0	2
14	0	0	1	1	0	1	4
15	0	0	1	1	1	0	6
16	0	0	1	1	1	1	8
17	0	1	0	0	0	0	10
18	0	1	0	0	0	1	12
19	0	1	0	0	1	0	14
20	0	1	0	0	1	1	16
21	0	1	0	1	0	0	18
22	0	1	0	1	0	1	20
23	0	1	0	1	1	0	22
24	0	1	0	1	1	1	24

Table 6. Volume Control Table (continued)

VOLUME STEP	VOL5	VOL4	VOL3	VOL2	VOL1	VOL0	GAIN (dB)
25	0	1	1	0	0	0	26
26	0	1	1	0	0	1	28
27	0	1	1	0	1	0	30
28	0	1	1	0	1	1	32
29	0	1	1	1	0	0	34
30	0	1	1	1	0	1	36
31	0	1	1	1	1	0	38
32	0	1	1	1	1	1	40
Do Not Use Volume Steps 33-60 See Table 7							
61	1	1	1	1	0	0	42
62	1	1	1	1	0	1	44
63	1	1	1	1	1	0	46
64	1	1	1	1	1	1	48

Table 7. Unused Volume Steps

VOLUME STEP	VOL5	VOL4	VOL3	VOL2	VOL1	VOL0	GAIN (dB)
33	1	0	0	0	0	0	-90
34	1	0	0	0	0	1	-25
35	1	0	0	0	1	0	-22
36	1	0	0	0	1	1	-19
37	1	0	0	1	0	0	-16
38	1	0	0	1	0	1	-13
39	1	0	0	1	1	0	-10
40	1	0	0	1	1	1	-8
41	1	0	1	0	0	0	-6
42	1	0	1	0	0	1	-4
43	1	0	1	0	1	0	0
44	1	0	1	0	1	1	4
45	1	0	1	1	0	0	8
46	1	0	1	1	0	1	12
47	1	0	1	1	1	0	14
48	1	0	1	1	1	1	16
49	1	1	0	0	0	0	18
50	1	1	0	0	0	1	20
51	1	1	0	0	1	0	22
52	1	1	0	0	1	1	24
53	1	1	0	1	0	0	26
54	1	1	0	1	0	1	28
55	1	1	0	1	1	0	30
56	1	1	0	1	1	1	32
57	1	1	1	0	0	0	34
58	1	1	1	0	0	1	36
59	1	1	1	0	1	0	38
60	1	1	1	0	1	1	40

VOLUME CONTROL

The LM48557 has a 64 step volume control, but only 36 steps are recommended for use. Use steps 1 through 32 and steps 61 through 64 to set the gain of the device. Accessing steps 33 through 60 results in the repeated gain conditions shown in [Table 7](#). Steps 33 through 60 are not tested and should not be used.

SHUTDOWN FUNCTION

The LM48557 features a low-power shutdown mode that disables the device lowers the quiescent current to $0.01\mu\text{A}$. Set bit B0 ($\overline{\text{SHDN}}$) of the Mode Control register to 0 to disable the amplifier and charge pump. Set $\overline{\text{SHDN}}$ to 1 for normal operation. Shutdown mode does not clear the I²C register. When re-enabled, the device returns to its previous volume setting. To clear the I²C register, either remove power from the device, or toggle $\overline{\text{RESET}}$ (see [RESET](#) section).

$\overline{\text{RESET}}$

The LM48557 features an active low reset input. Driving $\overline{\text{RESET}}$ low clears the I²C register. Volume control is set to 000000 (-90dB) and $\overline{\text{SHDN}}$ is set to 0, disabling the device. While $\overline{\text{RESET}}$ is low, the LM48557 ignores any I²C data. After the device is reset, and $\overline{\text{RESET}}$ is driven high, the LM48557 remains in shutdown mode with the volume set to -90dB. Re-enable the device by writing to the I²C register.

MUTE

The LM48557 features a mute mode. Set bit B1 (MUTE) of the Mode Control register to 1 to mute the device. In mute mode, the gain is set to -90dB, equivalent to the volume step 1. Set MUTE = 0 to unmute the device. Once unmuted, the device returns to its previous volume step.

TEST MODE

If enabled, TESTMODE does not affect device performance under normal operating conditions. Operating above the recommended supply voltage range with TESTMODE enabled can result in damage to the device.

PROPER SELECTION OF EXTERNAL COMPONENTS

Power Supply Bypassing/Filtering

Proper power supply bypassing is critical for low noise performance and high PSRR. Place the supply bypass capacitors as close to the device as possible. Place a $1\mu\text{F}$ ceramic capacitor from V_{DD} to GND. Additional bulk capacitance may be added as required.

Charge Pump Capacitor Selection

Use low ESR ceramic capacitors (less than $100\text{m}\Omega$) for optimum performance.

Charge Pump Flying Capacitor (C1)

The flying capacitor (C1) affects the load regulation and output impedance of the charge pump. A C1 value that is too low results in a loss of current drive, leading to a loss of amplifier headroom. A higher valued C1 improves load regulation and lowers charge pump output impedance to an extent. Above $2.2\mu\text{F}$, the $R_{\text{DS(ON)}}$ of the charge pump switches and the ESR of C1 and C2 dominate the output impedance. A lower value capacitor can be used in systems where low maximum output power requirements.

Charge Pump Hold Capacitor (C2)

The value and ESR of the hold capacitor (C2) directly affects the ripple on CPV_{SS} . Increasing the value of C2 reduces output ripple. Decreasing the ESR of C2 reduces both output ripple and charge pump output impedance. A lower value capacitor can be used in systems where low maximum output power requirements.

Input Capacitor Selection

Input capacitors block the DC component of the audio signal, eliminating any conflict between the DC component of the audio source and the bias voltage of the LM48557. The input capacitors create a high-pass filter with the input resistors R_{IN} . The -3dB point of the high pass filter is found using the equation below.

$$f = 1 / 2\pi R_{IN} C_{IN} \quad (\text{Hz}) \quad (1)$$

Where the value of R_{IN} is given in the [Electrical Characteristics Table](#).

High pass filtering the audio signal helps protect the speakers. When the LM48557 is using a single-ended source, power supply noise on the ground is seen as an input signal. Setting the high-pass filter point above the power supply noise frequencies, 217Hz in a GSM phone, for example, filters out the noise such that it is not amplified and heard on the output. Capacitors with a tolerance of 10% or better are recommended for impedance matching and improved CMRR and PSRR.

COMMON MODE SENSE

The LM48557 features a common mode sense pin (VCM, pin A3) that includes additional common mode cancelling circuitry that improves the CMRR. When the volume control is set at a high gain step such as 48dB, any mismatch in the input capacitors would degrade CMRR performance significantly. With the VCM pin connected to the ground of the input source, it takes the input capacitor mismatches out of the equation and therefore improves the CMRR. Another advantage with this feature is that only one input capacitor is needed in the single-ended configuration as opposed to two well matched capacitors. See next section for details of different configurations of the LM48857.

SINGLE-ENDED INPUT CONFIGURATION

Ground-Referenced Audio Source

The LM48557 input stage is compatible with ground-referenced input sources, such as CODECs with an integrated headphone amplifier. Connect either input, IN+ or IN- to the CODEC output, and connect the unused input and VCM to the CODEC output ground ([Figure 22](#)). An input coupling capacitor in series with the source and device input is recommended to block the CODEC output offset voltage, minimizing click and pop and zipper noise during volume transitions.

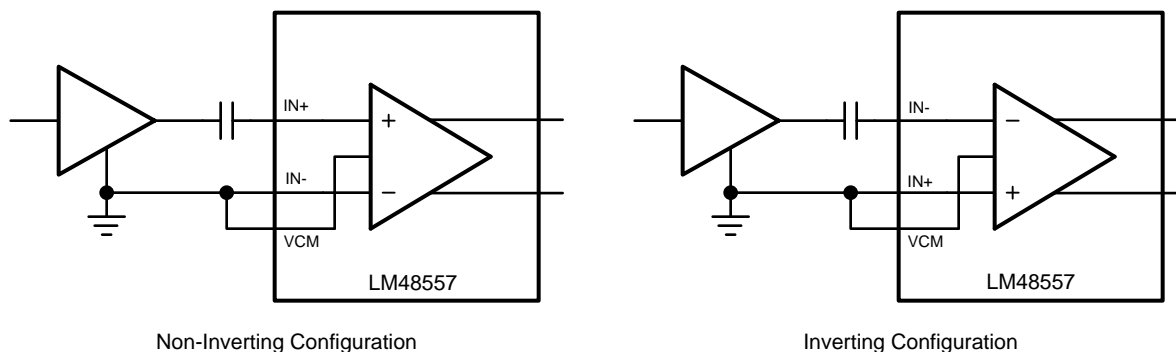

Figure 22. Single-Ended Input Configuration with a Ground-Referenced Source

NON-GROUND REFERENCED AUDIO SOURCE

Stereo-to-Mono Conversion

The LM48557 can convert a single-ended stereo signal to a mono BTL signal ([Figure 23](#)). Connect the left and right CODEC outputs in parallel through two equal value resistors to either IN+ or IN-, and connect the unused input and VCM to the CODEC ground. Select the value of the resistors based on the desired frequency response created by the combination of the input resistor and the input coupling capacitor.

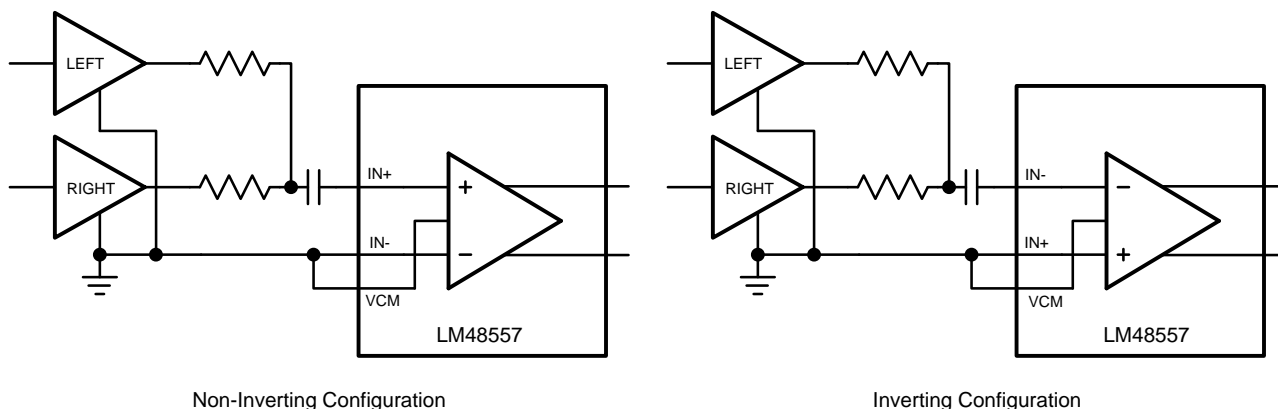

Figure 23. Single-Ended Stereo-to-Mono BTL Conversion

PCB Layout Guidelines

Minimize trace impedance of the power, ground and all output traces for optimum performance. Voltage loss due to trace resistance between the LM48557 and the load results in decreased output power and efficiency. Trace resistance between the power supply and ground has the same effect as a poorly regulated supply, increased ripple and reduced peak output power. Use wide traces for power supply inputs and amplifier outputs to minimize losses due to trace resistance, as well as route heat away from the device. Proper grounding improves audio performance, minimizes crosstalk between channels and prevents switching noise from interfering with the audio signal. Use of power and ground planes is recommended.

Place all digital components and route digital signal traces as far as possible from analog components and traces. Do not run digital and analog traces in parallel on the same PCB layer. If digital and analog signal lines must cross either over or under each other, ensure that they cross in a perpendicular fashion.

Table 8. LM48557TL Demoboard Bill of Materials

Designator	Quantity	Description
U1	1	LM48557TL Differential, Mono, Ceramic Speaker Driver with I ² C Volume Control, and Reset
C1, C2, C5, C6, C7	5	CAP CERAMIC 2.2μF 10V X5R 10% 0603
C3, C4	2	CAP .1μF 16V CERAMIC X7R 10% 1206
C8	1	CAP TANT LOESR 10μF 16V 10% SMD
J2	1	CONN SOCKET PCB VERT 16POS .1"
JU1, JU2, JU3, JU4, VCM, VDD, GND, I ² CV _{DD} , IN+, IN-, OUT+, OUT-	12	CONN HEADER VERT .100 2POS 30Au
JU5	1	CONN HEADER VERT .100 3POS 30Au
R1, R2	2	RES 5.1K OHM 1/10W 5% 0603 SMD
R3	1	RES 20K OHM 1/10W 5% 0603 SMD
JU1_SH, JU2_SH, JU3_SH, JU5_SH	4	Jumper Shunt w/handle, 30uin gold plated, 0.100" pitch

PC Board Layout

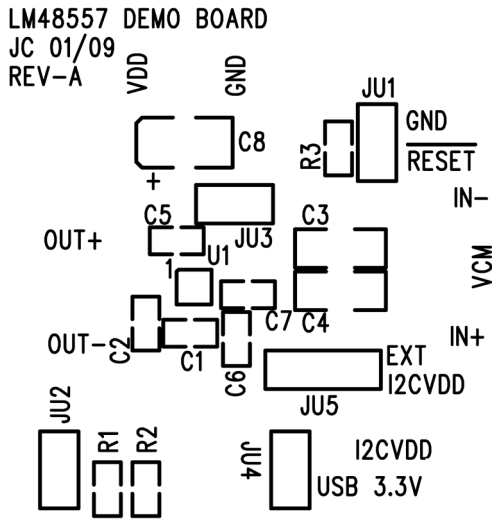

Figure 24. Silk Screen

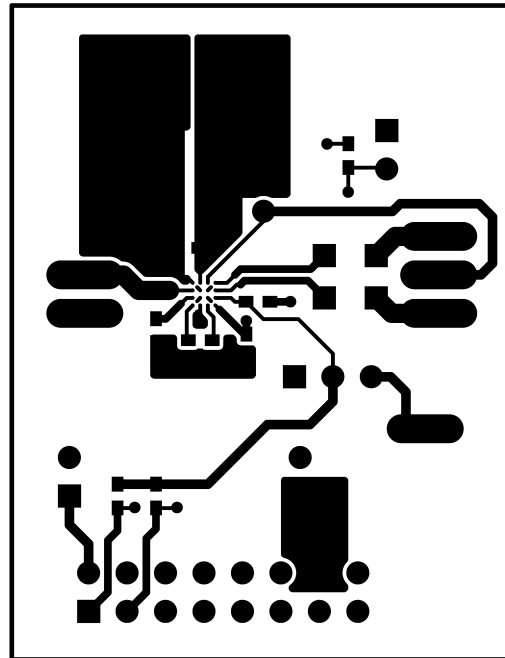

Figure 25. Top Layer

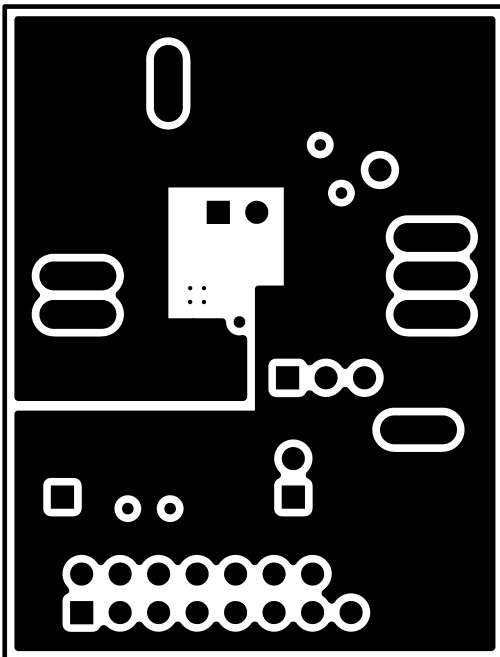

Figure 26. Layer 2

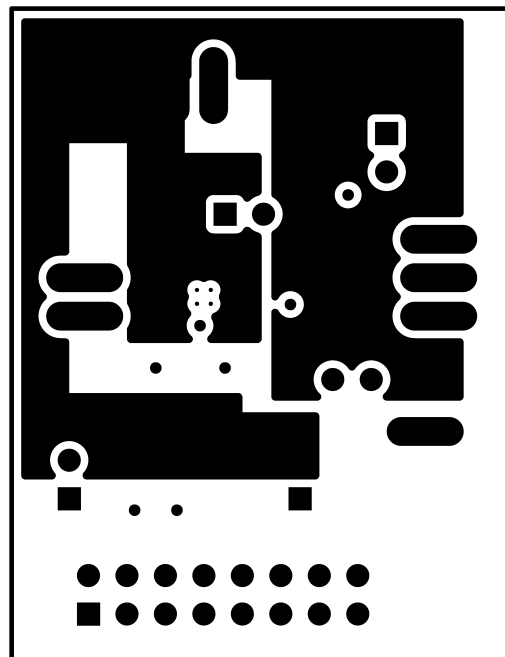

Figure 27. Layer 3

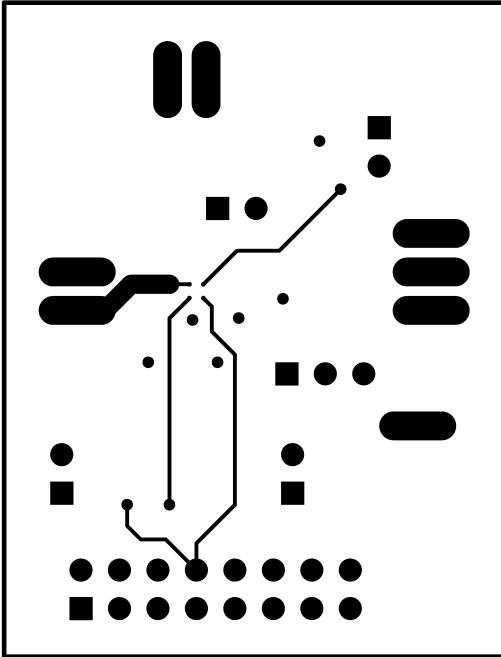

Figure 28. Bottom Layer

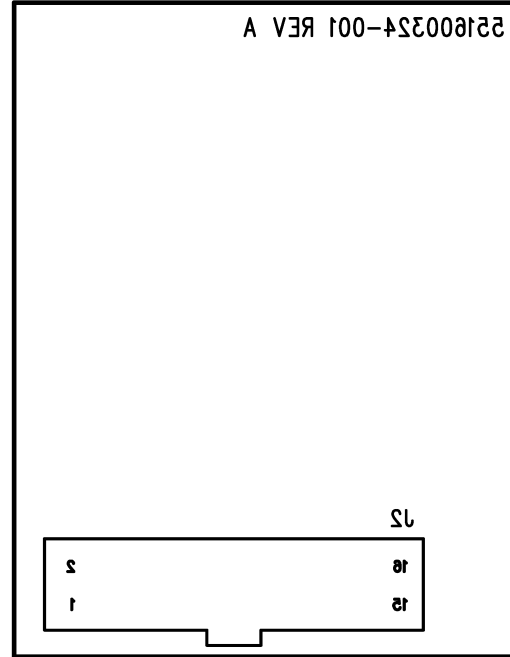

Figure 29. Bottom Silkscreen

Demo Board Schematic

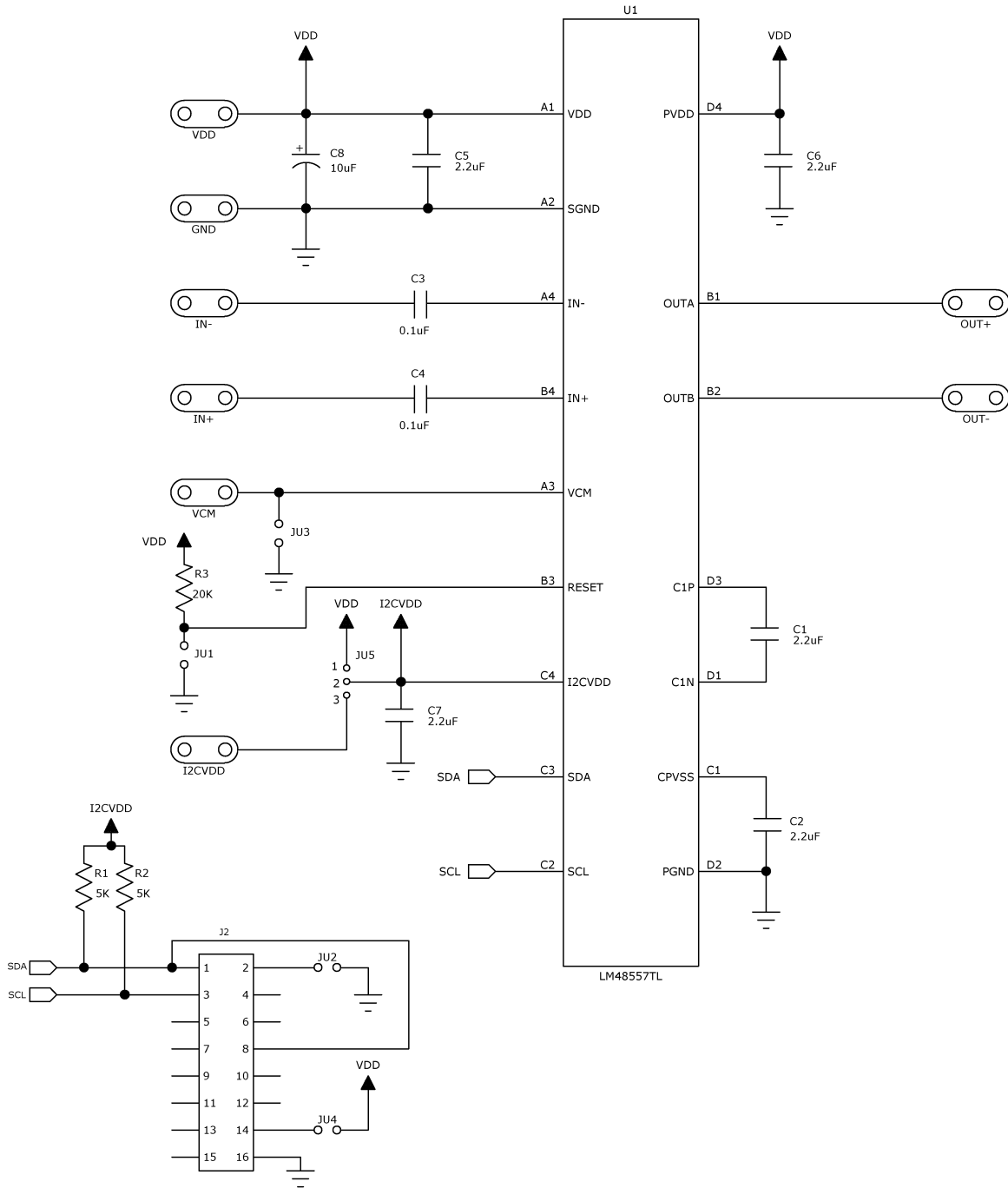

Figure 30. LM48557 Demo Board Schematic

Revision History

Rev	Date	Description
1.0	07/08/09	Initial released.
1.01	07/15/09	Deleted the "Tru-GND..." trademark on the cover page.
1.02	08/05/09	Text edits.
1.03	08/06/09	Fixed a typo error.
1.04	01/11/10	Added the LM48557UR package drawing, top markings, and the marketing outline.
D	02/05/2013	Changed layout of National Data Sheet to TI format.

PACKAGING INFORMATION

Orderable Device	Status (1)	Package Type	Package Drawing	Pins	Package Qty	Eco Plan (2)	Lead/Ball Finish	MSL Peak Temp (3)	Op Temp (°C)	Top-Side Markings (4)	Samples
LM48557TL/NOPB	ACTIVE	DSBGA	YZR	16	250	Green (RoHS & no Sb/Br)	SNAGCU	Level-1-260C-UNLIM		GM2	Samples
LM48557TLX/NOPB	ACTIVE	DSBGA	YZR	16	3000	Green (RoHS & no Sb/Br)	SNAGCU	Level-1-260C-UNLIM		GM2	Samples
LM48557UR/NOPB	ACTIVE	DSBGA	YPD	16	250	Green (RoHS & no Sb/Br)	SNAGCU	Level-1-260C-UNLIM		GN5	Samples
LM48557URX/NOPB	ACTIVE	DSBGA	YPD	16	3000	Green (RoHS & no Sb/Br)	SNAGCU	Level-1-260C-UNLIM		GN5	Samples

(1) The marketing status values are defined as follows:

ACTIVE: Product device recommended for new designs.

LIFEBUY: TI has announced that the device will be discontinued, and a lifetime-buy period is in effect.

NRND: Not recommended for new designs. Device is in production to support existing customers, but TI does not recommend using this part in a new design.

PREVIEW: Device has been announced but is not in production. Samples may or may not be available.

OBSOLETE: TI has discontinued the production of the device.

(2) Eco Plan - The planned eco-friendly classification: Pb-Free (RoHS), Pb-Free (RoHS Exempt), or Green (RoHS & no Sb/Br) - please check <http://www.ti.com/productcontent> for the latest availability information and additional product content details.

TBD: The Pb-Free/Green conversion plan has not been defined.

Pb-Free (RoHS): TI's terms "Lead-Free" or "Pb-Free" mean semiconductor products that are compatible with the current RoHS requirements for all 6 substances, including the requirement that lead not exceed 0.1% by weight in homogeneous materials. Where designed to be soldered at high temperatures, TI Pb-Free products are suitable for use in specified lead-free processes.

Pb-Free (RoHS Exempt): This component has a RoHS exemption for either 1) lead-based flip-chip solder bumps used between the die and package, or 2) lead-based die adhesive used between the die and leadframe. The component is otherwise considered Pb-Free (RoHS compatible) as defined above.

Green (RoHS & no Sb/Br): TI defines "Green" to mean Pb-Free (RoHS compatible), and free of Bromine (Br) and Antimony (Sb) based flame retardants (Br or Sb do not exceed 0.1% by weight in homogeneous material)

(3) MSL, Peak Temp. -- The Moisture Sensitivity Level rating according to the JEDEC industry standard classifications, and peak solder temperature.

(4) Multiple Top-Side Markings will be inside parentheses. Only one Top-Side Marking contained in parentheses and separated by a "~" will appear on a device. If a line is indented then it is a continuation of the previous line and the two combined represent the entire Top-Side Marking for that device.

Important Information and Disclaimer: The information provided on this page represents TI's knowledge and belief as of the date that it is provided. TI bases its knowledge and belief on information provided by third parties, and makes no representation or warranty as to the accuracy of such information. Efforts are underway to better integrate information from third parties. TI has taken and continues to take reasonable steps to provide representative and accurate information but may not have conducted destructive testing or chemical analysis on incoming materials and chemicals. TI and TI suppliers consider certain information to be proprietary, and thus CAS numbers and other limited information may not be available for release.

In no event shall TI's liability arising out of such information exceed the total purchase price of the TI part(s) at issue in this document sold by TI to Customer on an annual basis.

TAPE AND REEL INFORMATION

QUADRANT ASSIGNMENTS FOR PIN 1 ORIENTATION IN TAPE

*All dimensions are nominal

Device	Package Type	Package Drawing	Pins	SPQ	Reel Diameter (mm)	Reel Width W1 (mm)	A0 (mm)	B0 (mm)	K0 (mm)	P1 (mm)	W (mm)	Pin1 Quadrant
LM48557TL/NOPB	DSBGA	YZR	16	250	178.0	8.4	2.08	2.08	0.76	4.0	8.0	Q1
LM48557TLX/NOPB	DSBGA	YZR	16	3000	178.0	8.4	2.08	2.08	0.76	4.0	8.0	Q1
LM48557UR/NOPB	DSBGA	YPD	16	250	178.0	8.4	2.11	2.11	0.56	4.0	8.0	Q1
LM48557URX/NOPB	DSBGA	YPD	16	3000	178.0	8.4	2.11	2.11	0.56	4.0	8.0	Q1

TAPE AND REEL BOX DIMENSIONS

*All dimensions are nominal

Device	Package Type	Package Drawing	Pins	SPQ	Length (mm)	Width (mm)	Height (mm)
LM48557TL/NOPB	DSBGA	YZR	16	250	210.0	185.0	35.0
LM48557TLX/NOPB	DSBGA	YZR	16	3000	210.0	185.0	35.0
LM48557UR/NOPB	DSBGA	YPD	16	250	210.0	185.0	35.0
LM48557URX/NOPB	DSBGA	YPD	16	3000	210.0	185.0	35.0

IMPORTANT NOTICE

Texas Instruments Incorporated (TI) reserves the right to make corrections, enhancements, improvements and other changes to its semiconductor products and services per JESD46, latest issue, and to discontinue any product or service per JESD48, latest issue. Buyers should obtain the latest relevant information before placing orders and should verify that such information is current and complete.

TI's published terms of sale for semiconductor products (<http://www.ti.com/sc/docs/stdterms.htm>) apply to the sale of packaged integrated circuit products that TI has qualified and released to market. Additional terms may apply to the use or sale of other types of TI products and services.

Reproduction of significant portions of TI information in TI data sheets is permissible only if reproduction is without alteration and is accompanied by all associated warranties, conditions, limitations, and notices. TI is not responsible or liable for such reproduced documentation. Information of third parties may be subject to additional restrictions. Resale of TI products or services with statements different from or beyond the parameters stated by TI for that product or service voids all express and any implied warranties for the associated TI product or service and is an unfair and deceptive business practice. TI is not responsible or liable for any such statements.

Buyers and others who are developing systems that incorporate TI products (collectively, "Designers") understand and agree that Designers remain responsible for using their independent analysis, evaluation and judgment in designing their applications and that Designers have full and exclusive responsibility to assure the safety of Designers' applications and compliance of their applications (and of all TI products used in or for Designers' applications) with all applicable regulations, laws and other applicable requirements. Designer represents that, with respect to their applications, Designer has all the necessary expertise to create and implement safeguards that (1) anticipate dangerous consequences of failures, (2) monitor failures and their consequences, and (3) lessen the likelihood of failures that might cause harm and take appropriate actions. Designer agrees that prior to using or distributing any applications that include TI products, Designer will thoroughly test such applications and the functionality of such TI products as used in such applications.

TI's provision of technical, application or other design advice, quality characterization, reliability data or other services or information, including, but not limited to, reference designs and materials relating to evaluation modules, (collectively, "TI Resources") are intended to assist designers who are developing applications that incorporate TI products; by downloading, accessing or using TI Resources in any way, Designer (individually or, if Designer is acting on behalf of a company, Designer's company) agrees to use any particular TI Resource solely for this purpose and subject to the terms of this Notice.

TI's provision of TI Resources does not expand or otherwise alter TI's applicable published warranties or warranty disclaimers for TI products, and no additional obligations or liabilities arise from TI providing such TI Resources. TI reserves the right to make corrections, enhancements, improvements and other changes to its TI Resources. TI has not conducted any testing other than that specifically described in the published documentation for a particular TI Resource.

Designer is authorized to use, copy and modify any individual TI Resource only in connection with the development of applications that include the TI product(s) identified in such TI Resource. NO OTHER LICENSE, EXPRESS OR IMPLIED, BY ESTOPPEL OR OTHERWISE TO ANY OTHER TI INTELLECTUAL PROPERTY RIGHT, AND NO LICENSE TO ANY TECHNOLOGY OR INTELLECTUAL PROPERTY RIGHT OF TI OR ANY THIRD PARTY IS GRANTED HEREIN, including but not limited to any patent right, copyright, mask work right, or other intellectual property right relating to any combination, machine, or process in which TI products or services are used. Information regarding or referencing third-party products or services does not constitute a license to use such products or services, or a warranty or endorsement thereof. Use of TI Resources may require a license from a third party under the patents or other intellectual property of the third party, or a license from TI under the patents or other intellectual property of TI.

TI RESOURCES ARE PROVIDED "AS IS" AND WITH ALL FAULTS. TI DISCLAIMS ALL OTHER WARRANTIES OR REPRESENTATIONS, EXPRESS OR IMPLIED, REGARDING RESOURCES OR USE THEREOF, INCLUDING BUT NOT LIMITED TO ACCURACY OR COMPLETENESS, TITLE, ANY EPIDEMIC FAILURE WARRANTY AND ANY IMPLIED WARRANTIES OF MERCHANTABILITY, FITNESS FOR A PARTICULAR PURPOSE, AND NON-INFRINGEMENT OF ANY THIRD PARTY INTELLECTUAL PROPERTY RIGHTS. TI SHALL NOT BE LIABLE FOR AND SHALL NOT DEFEND OR INDEMNIFY DESIGNER AGAINST ANY CLAIM, INCLUDING BUT NOT LIMITED TO ANY INFRINGEMENT CLAIM THAT RELATES TO OR IS BASED ON ANY COMBINATION OF PRODUCTS EVEN IF DESCRIBED IN TI RESOURCES OR OTHERWISE. IN NO EVENT SHALL TI BE LIABLE FOR ANY ACTUAL, DIRECT, SPECIAL, COLLATERAL, INDIRECT, PUNITIVE, INCIDENTAL, CONSEQUENTIAL OR EXEMPLARY DAMAGES IN CONNECTION WITH OR ARISING OUT OF TI RESOURCES OR USE THEREOF, AND REGARDLESS OF WHETHER TI HAS BEEN ADVISED OF THE POSSIBILITY OF SUCH DAMAGES.

Unless TI has explicitly designated an individual product as meeting the requirements of a particular industry standard (e.g., ISO/TS 16949 and ISO 26262), TI is not responsible for any failure to meet such industry standard requirements.

Where TI specifically promotes products as facilitating functional safety or as compliant with industry functional safety standards, such products are intended to help enable customers to design and create their own applications that meet applicable functional safety standards and requirements. Using products in an application does not by itself establish any safety features in the application. Designers must ensure compliance with safety-related requirements and standards applicable to their applications. Designer may not use any TI products in life-critical medical equipment unless authorized officers of the parties have executed a special contract specifically governing such use. Life-critical medical equipment is medical equipment where failure of such equipment would cause serious bodily injury or death (e.g., life support, pacemakers, defibrillators, heart pumps, neurostimulators, and implantables). Such equipment includes, without limitation, all medical devices identified by the U.S. Food and Drug Administration as Class III devices and equivalent classifications outside the U.S.

TI may expressly designate certain products as completing a particular qualification (e.g., Q100, Military Grade, or Enhanced Product). Designers agree that it has the necessary expertise to select the product with the appropriate qualification designation for their applications and that proper product selection is at Designers' own risk. Designers are solely responsible for compliance with all legal and regulatory requirements in connection with such selection.

Designer will fully indemnify TI and its representatives against any damages, costs, losses, and/or liabilities arising out of Designer's non-compliance with the terms and provisions of this Notice.

Looking for pricing, stock, or lifecycle information?

Click below to explore more details on WIN SOURCE:

 [View LM48557TLX on WIN SOURCE](#)

 [Texas Instruments](#) Information

Optimize Your Supply Chain with WIN SOURCE Solutions

-  Global Sourcing Solution
-  Obsolete Management
-  Cost Control Management
-  Shortage Management
-  Alternative Solution
-  Excess Inventory Management