



**THE DATASHEET OF  
LM4730TA**



## LM4730 Stereo 14W Audio Power Amplifier with Mute and Standby Modes

Check for Samples: [LM4730](#)

### FEATURES

- Minimal Amount of External Components Necessary
- Quiet Fade-in/out Mute Mode
- Low Current Standby-mode

### APPLICATIONS

- Audio Amplifier for High-end Stereo TVs
- Audio Amplifier for Component Stereo
- Audio Amplifier for Compact Stereo
- Audio Amplifier for PC Satellite Speaker Systems
- Audio Amplifier for Self Powered Speakers

### KEY SPECIFICATIONS

- Output Power into 4Ω or 8Ω, 10% THD+N 14W (typ)
- THD+N at 1kHz with 2 X 1W into 8Ω 0.02% (typ)
- Mute Attenuation 85dB (typ)
- PSRR with fRIPPLE = 120Hz, VRIPPLE = 1VRMS 50dB (typ)
- Slew Rate 18V/μs (typ)
- Standby Current (+/-17V) 3.5mA (typ)

### DESCRIPTION

The LM4730 is a stereo audio amplifier capable of delivering typically 14W per channel of continuous average output power into a 4Ω or 8Ω load with less than 10% THD+N from 20Hz - 20kHz.

Each amplifier has an independent smooth transition fade-in/out mute and a power conserving standby mode which can be controlled by external logic.

The LM4730 has short circuit protection and a thermal shut down feature that is activated when the die temperature exceeds 150°C. The LM4730 also has a under voltage lock out feature for click and pop free power off and on.

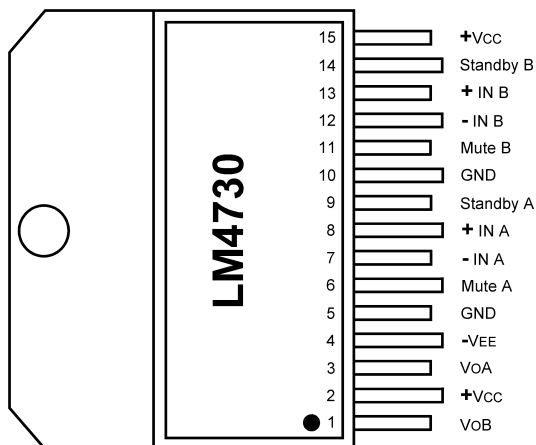
The LM4730 has a wide operating supply range from +/-10V - +/-25V allowing for lower cost unregulated power supplies to be used.



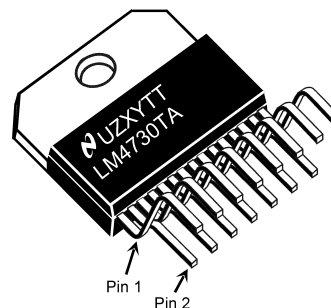
Please be aware that an important notice concerning availability, standard warranty, and use in critical applications of Texas Instruments semiconductor products and disclaimers thereto appears at the end of this data sheet.

All trademarks are the property of their respective owners.

## Connection Diagram

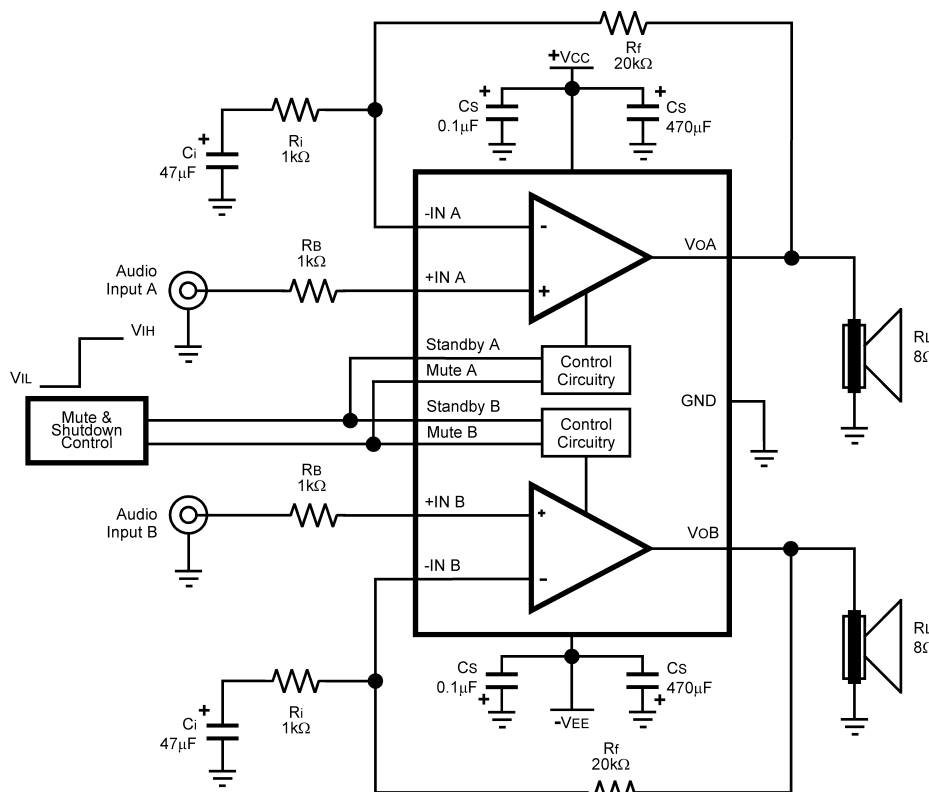


**Figure 1. Plastic Package<sup>(1)</sup> - Top View**  
**Non-Isolated Package**  
 See Package Number TA15A



**Figure 2. TO-220 Top Marking<sup>(1)</sup> - Top View**  
**U - Wafer Fab Code**  
**Z - Assembly Plant Code**  
**XY - Date Code**  
**TT - Die Traceability**  
**LM4730TA - LM4730TA**

## Typical Application



**Figure 3. Typical Audio Amplifier Application Circuit**

- (1) The LM4730TA package TA15A is a non-isolated package setting the tab of the device and the heat sink to  $V^-$  potential when the LM4730TA is directly mounted to the heat sink using only thermal compound. If a mica washer is used in addition to thermal compound,  $\theta_{CS}$  (case to sink) is increased, but the heat sink will be electrically isolated from  $V^-$ .



These devices have limited built-in ESD protection. The leads should be shorted together or the device placed in conductive foam during storage or handling to prevent electrostatic damage to the MOS gates.

### Absolute Maximum Ratings<sup>(1)(2)(3)</sup>

Supply Voltage $ V^+  +  V^- $		50V
Common Mode Input Voltage		$V^+$ or $V^-$
Differential Input Voltage		50V
Output Current		Internally Limited
Power Dissipation <sup>(4)</sup>		40W
ESD Susceptibility <sup>(5)</sup>		2.0kV
ESD Susceptibility <sup>(6)</sup>		250V
Junction Temperature ( $T_{JMAX}$ ) <sup>(7)</sup>		150°C
Soldering Information	T Package (10 sec.)	260°C
Storage Temperature		-40°C to +150°C
Thermal Resistance	$\theta_{JA}$ (TA)	43°C/W
	$\theta_{JC}$ (TA)	1.5°C/W

- (1) Absolute Maximum Ratings indicate limits beyond which damage to the device may occur. Operating Ratings indicate conditions for which the device is functional, but do not ensure specific performance limits. Electrical Characteristics state DC and AC electrical specifications under particular test conditions which ensure specific performance limits. This assumes that the device is within the Operating Ratings. Specifications are not ensured for parameters where no limit is given. However, the typical value is a good indication of a device's performance.
- (2) All voltages are measured with respect to the ground pin, unless otherwise specified.
- (3) If Military/Aerospace specified devices are required, please contact the Texas Instruments Sales Office/ Distributors for availability and specifications.
- (4) The maximum power dissipation must be de-rated at elevated temperatures and is dictated by  $T_{JMAX}$ ,  $\theta_{JC}$ , and the ambient temperature  $T_A$ . The maximum allowable power dissipation is  $P_{DMAX} = (T_{JMAX} - T_A) / \theta_{JC}$  or the number given in the Absolute Maximum Ratings, whichever is lower. For the LM4730,  $T_{JMAX} = 150^\circ\text{C}$  and the typical  $\theta_{JC}$  is 1.5°C/W for the TA15A package. Refer to the Thermal Considerations section for more information.
- (5) Human body model, 100 pF discharged through a 1.5 kΩ resistor.
- (6) Machine Model: a 220pF - 240pF discharged through all pins.
- (7) The operating junction temperature maximum is 150°C. However, the instantaneous Safe Operating Area temperature is 250°C.

### Operating Ratings<sup>(1)(2)</sup>

Temperature Range	$T_{MIN} \leq T_A \leq T_{MAX}$	$-20^\circ\text{C} \leq T_A \leq +85^\circ\text{C}$
Supply Voltage $ V^+  +  V^- $		$20\text{V} \leq V_{TOTAL} \leq 50\text{V}$

- (1) All voltages are measured with respect to the ground pin, unless otherwise specified.
- (2) Absolute Maximum Ratings indicate limits beyond which damage to the device may occur. Operating Ratings indicate conditions for which the device is functional, but do not ensure specific performance limits. Electrical Characteristics state DC and AC electrical specifications under particular test conditions which ensure specific performance limits. This assumes that the device is within the Operating Ratings. Specifications are not ensured for parameters where no limit is given. However, the typical value is a good indication of a device's performance.

## Electrical Characteristics<sup>(1)(2)</sup>

The following specifications apply for  $V^+ = +17V$ ,  $V^- = -17V$  and  $R_L = 8\Omega$  unless otherwise specified. Limits apply for  $T_A = 25^\circ C$ .

Symbol	Parameter	Conditions	LM4730		Units (Limits)
			Typical <sup>(3)</sup>	Limit <sup>(4)(5)</sup>	
$ V^+  +  V^- $	Power Supply Voltage <sup>(6)</sup>	GND - $V^- \geq 9V$		20 50	V (min) V (max)
$A_M$	Mute Attenuation		85		dB
$P_O$	Output Power (RMS)	THD+N = 10% (max), $f = 1kHz$ $ V^+  =  V^-  = 14V$ , $R_L = 4\Omega$ $ V^+  =  V^-  = 17V$ , $R_L = 8\Omega$	14 14	12 12	W (min) W (min)
		THD+N = 1% (max), $f = 1kHz$ $ V^+  =  V^-  = 14V$ , $R_L = 4\Omega$ $ V^+  =  V^-  = 17V$ , $R_L = 8\Omega$	11 11	9 9	W (min) W (min)
THD+N	Total Harmonic Distortion + Noise	$P_O = 1W$ , $f = 1kHz$ $A_V = 26dB$ $ V^+  =  V^-  = 14V$ , $R_L = 4\Omega$ $ V^+  =  V^-  = 17V$ , $R_L = 8\Omega$	0.03 0.02	0.5 0.3	% (max) % (max)
$X_{talk}$	Channel Separation	$P_O = 10W$ $f = 1kHz$ $f = 10kHz$	65 60		dB dB
SR	Slew Rate <sup>(7)</sup>	$V_{IN} = 2.0V_{p-p}$ , $t_{rise} = 2ns$	18		V/ $\mu s$
$I_{DD}$	Total Quiescent Power Supply Current	$V_{CM} = 0V$ , $V_O = 0V$ , $I_O = 0A$ Standby off (Play Mode) Standby on (Standby Mode)	90 3.5	100 6	mA (max) mA (max)
$V_{OS}$	Input Offset Voltage	$V_{CM} = 0V$ , $I_O = 0mA$	2.0	15	mV (max)
$I_B$	Input Bias Current	$V_{CM} = 0V$ , $I_O = 0mA$	0.2		$\mu A$
PSRR	Power Supply Rejection Ratio	$V_{RIPPLE} = 1V_{RMS}$ , $f_{RIPPLE} = 120Hz$ sine wave Inputs terminated to GND	50		dB
$A_{VOL}$	Open Loop Voltage Gain	$R_L = 2k\Omega$ , $\Delta V_O = 20V$	110		dB
$e_{IN}$	Input Noise	IHF — A-Weighting Filter $R_{IN} = 600\Omega$ (Input Referred)	2.0	8	$\mu V$ (max)
<b>Standby</b>					
$V_{IL}$	Standby Low Input Voltage	Not in Standby Mode (Play)		0.8	V (max)
$V_{IH}$	Standby High Input Voltage	In Standby Mode	2.0	2.5	V (min)
<b>Mute</b>					
$V_{IL}$	Mute Low Input Voltage	Not in Mute Mode (Play)		0.8	V (max)
$V_{IH}$	Mute High Input Voltage	In Mute Mode	2.0	2.5	V (min)

- (1) All voltages are measured with respect to the ground pin, unless otherwise specified.
- (2) Absolute Maximum Ratings indicate limits beyond which damage to the device may occur. Operating Ratings indicate conditions for which the device is functional, but do not ensure specific performance limits. Electrical Characteristics state DC and AC electrical specifications under particular test conditions which ensure specific performance limits. This assumes that the device is within the Operating Ratings. Specifications are not ensured for parameters where no limit is given. However, the typical value is a good indication of a device's performance.
- (3) Typical specifications are specified at  $25^\circ C$  and represent the parametric norm.
- (4) Tested limits are guaranteed to National's AOQL (Average Outgoing Quality Level).
- (5) Datasheet min/max specification limits are guaranteed by design, test, or statistical analysis.
- (6)  $V^-$  must have at least  $-9V$  at its pin with reference to GND in order for the under-voltage protection circuitry to be disabled. In addition, the voltage differential between  $V^+$  and  $V^-$  must be greater than  $14V$ .
- (7) The feedback compensation network limits the bandwidth of the closed-loop response causing the skew rate to be reduced by the high frequency roll-off. Without feedback compensation the slew rate is typically larger.

### Bridged Amplifier Application Circuit

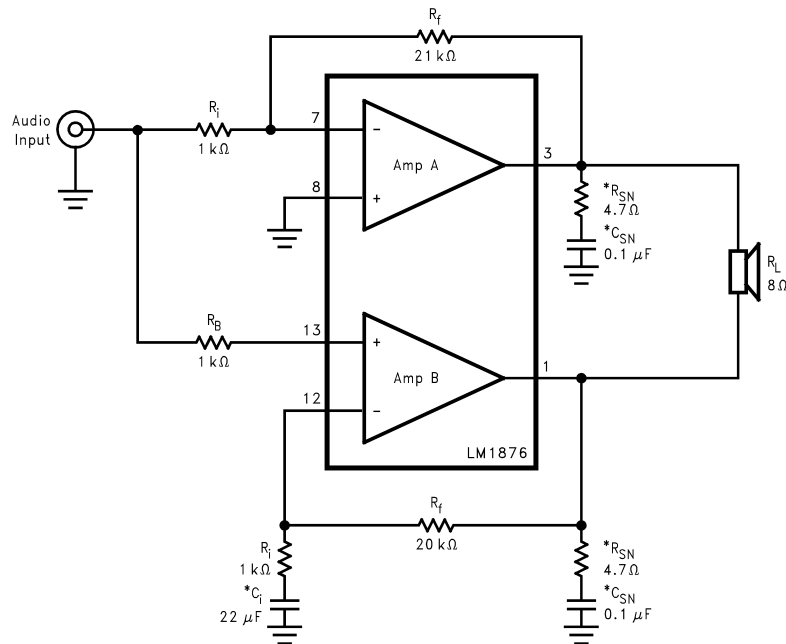


Figure 4. Bridged Amplifier Application Circuit

### Single Supply Application Circuit

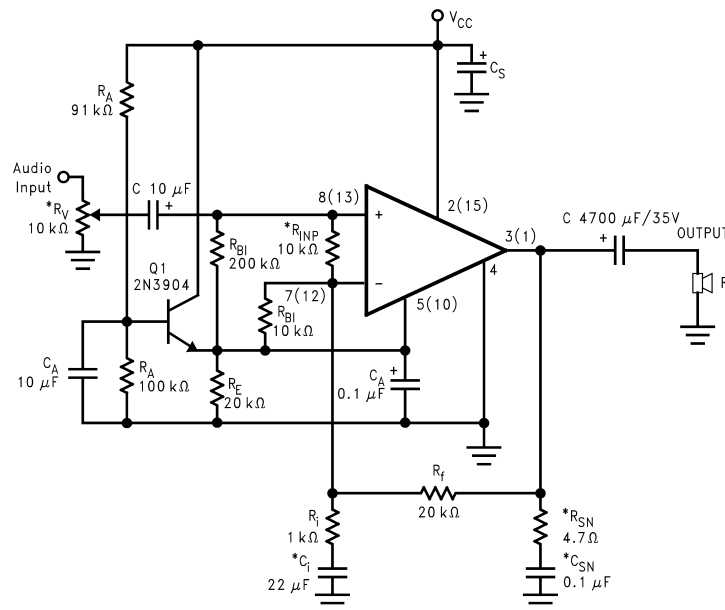


Figure 5. Single Supply Amplifier Application Circuit

#### NOTE

\*Optional components dependent upon specific design requirements.

## Auxiliary Amplifier Application Circuit

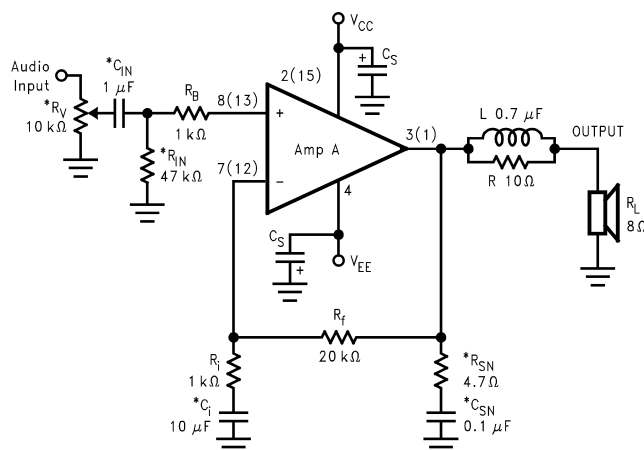


Figure 6. Special Audio Amplifier Application Circuit

## External Components Description

( See [Figure 3](#), [Figure 4](#), [Figure 5](#), [Figure 6](#) )

Components		Functional Description
1	$R_B$	Prevents currents from entering the amplifier's non-inverting input which may be passed through to the load upon power down of the system due to the low input impedance of the circuitry when the undervoltage circuitry is off. This phenomenon occurs when the supply voltages are below 1.5V.
2	$R_i$	Inverting input resistance to provide AC gain in conjunction with $R_f$ .
3	$R_f$	Feedback resistance to provide AC gain in conjunction with $R_i$ .
4	$C_i$ (1)	Feedback capacitor which ensures unity gain at DC. Also creates a highpass filter with $R_i$ at $f_C = 1/(2\pi R_i C_i)$ .
5	$C_S$	Provides power supply filtering and bypassing. Refer to the <a href="#">SUPPLY BYPASSING</a> application section for proper placement and selection of bypass capacitors.
6	$R_V$ (1)	Acts as a volume control by setting the input voltage level.
7	$R_{IN}$ (1)	Sets the amplifier's input terminals DC bias point when $C_{IN}$ is present in the circuit. Also works with $C_{IN}$ to create a highpass filter at $f_C = 1/(2\pi R_{IN} C_{IN})$ . Refer to <a href="#">Figure 6</a> .
8	$C_{IN}$ (1)	Input capacitor which blocks the input signal's DC offsets from being passed onto the amplifier's inputs.
9	$R_{SN}$ (1)	Works with $C_{SN}$ to stabilize the output stage by creating a pole that reduces high frequency instabilities.
10	$C_{SN}$ (1)	Works with $R_{SN}$ to stabilize the output stage by creating a pole that reduces high frequency instabilities. The pole is set at $f_C = 1/(2\pi R_{SN} C_{SN})$ . Refer to <a href="#">Figure 6</a> .
11	$L$ (1)	Provides high impedance at high frequencies so that R may decouple a highly capacitive load and reduce the Q of the series resonant circuit. Also provides a low impedance at low frequencies to short out R and pass audio signals to the load. Refer to <a href="#">Figure 6</a> .
12	$R$ (1)	
13	$R_A$	Provides DC voltage biasing for the transistor Q1 in single supply operation.
14	$C_A$	Provides bias filtering for single supply operation.
15	$R_{INP}$ (1)	Limits the voltage difference between the amplifier's inputs for single supply operation. Refer to the <a href="#">CLICKS AND POPS</a> application section for a more detailed explanation of the function of $R_{INP}$ .
16	$R_{BI}$	Provides input bias current for single supply operation. Refer to the <a href="#">CLICKS AND POPS</a> application section for a more detailed explanation of the function of $R_{BI}$ .
17	$R_E$	Establishes a fixed DC current for the transistor Q1 in single supply operation. This resistor stabilizes the half-supply point along with $C_A$ .

(1) Optional components dependent upon specific design requirements.

Typical Performance Characteristics

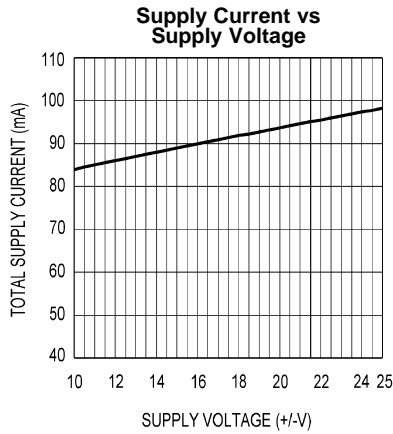


Figure 7.

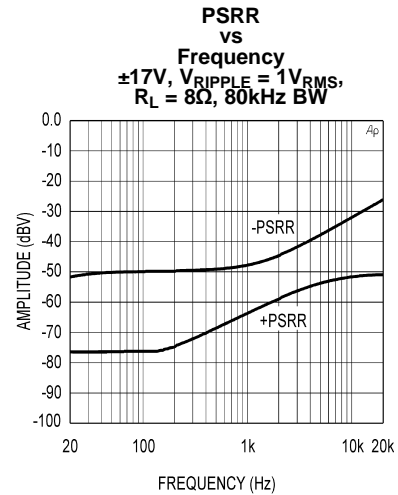


Figure 8.

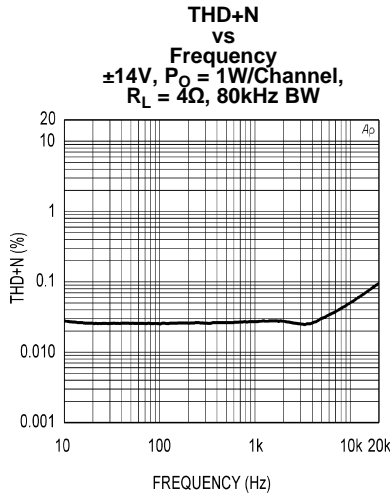


Figure 9.

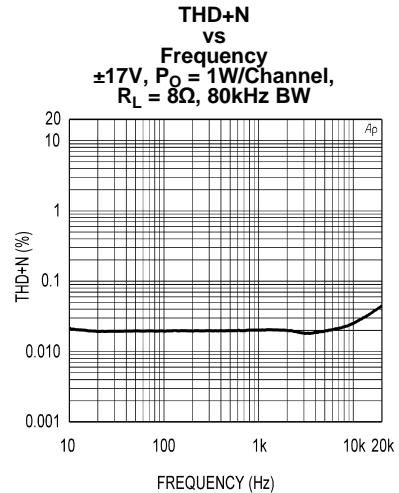


Figure 10.

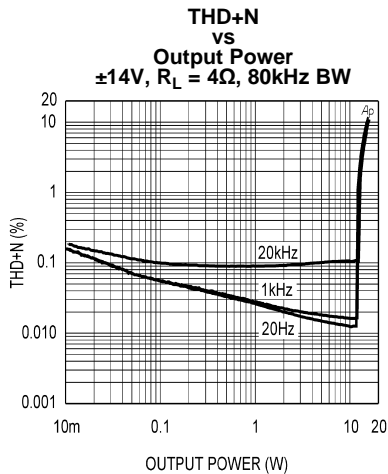


Figure 11.

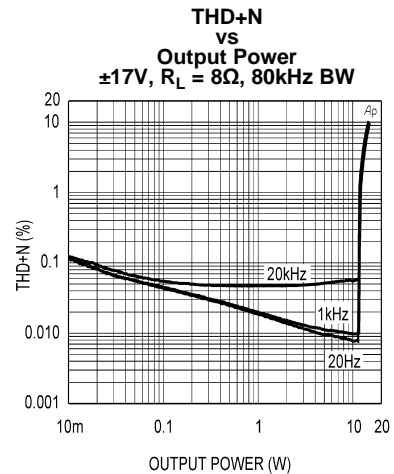


Figure 12.

**Typical Performance Characteristics (continued)**

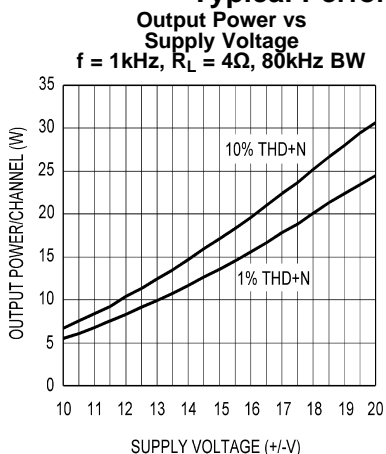


Figure 13.

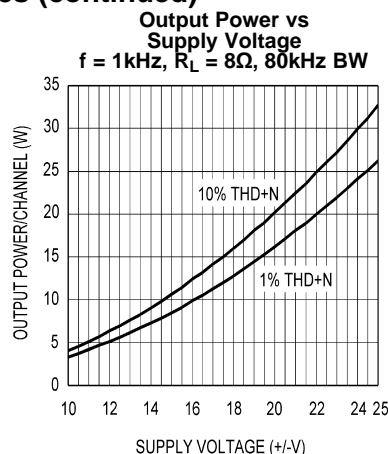


Figure 14.

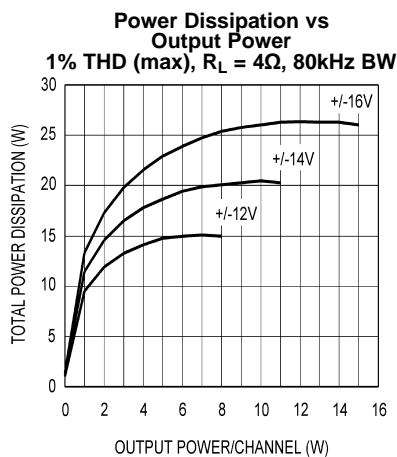


Figure 15.

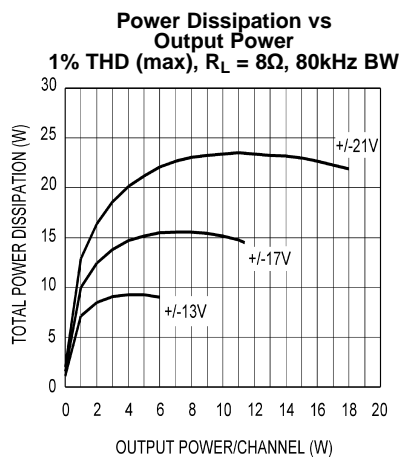


Figure 16.

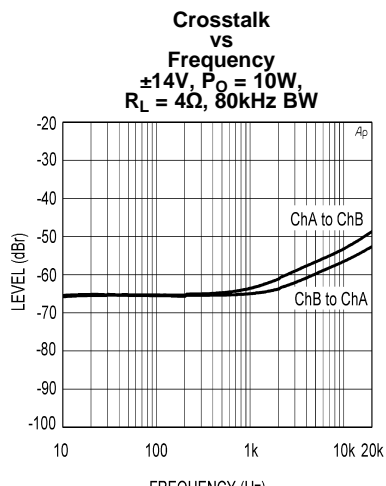


Figure 17.

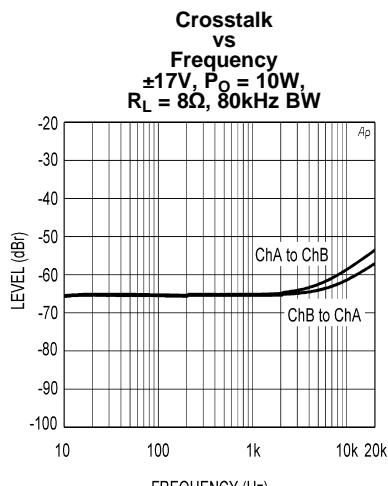
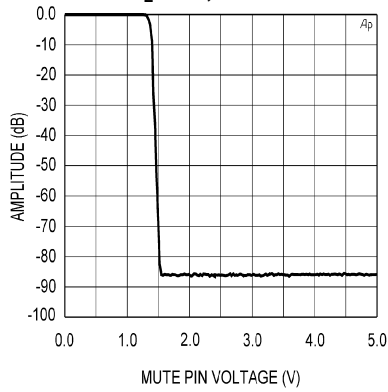


Figure 18.

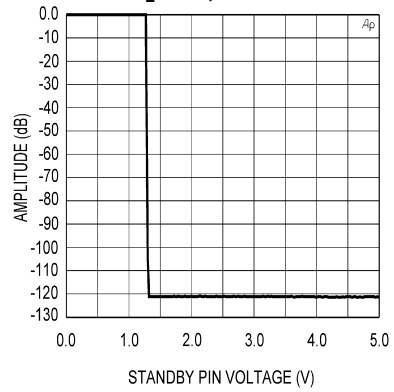
**Typical Performance Characteristics (continued)**

**Mute Attenuation vs Mute Pin Voltage**  
 $\pm 17V$ ,  $P_O = 1W$ ,  
 $R_L = 8\Omega$ , 80kHz BW



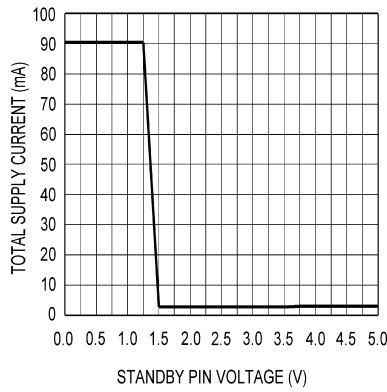
**Figure 19.**

**Standby Attenuation vs Standby Pin Voltage**  
 $\pm 17V$ ,  $P_O = 1W$ ,  
 $R_L = 8\Omega$ , 80kHz BW



**Figure 20.**

**Supply Current vs Standby Pin Voltage**  
 $\pm 17V$



**Figure 21.**

## APPLICATION INFORMATION

### MUTE MODE

By placing a logic-high voltage on the mute pins, the signal going into the amplifiers will be muted. If the mute pins are left floating or connected to a logic-low voltage, the amplifiers will be in a non-muted state. There are two mute pins, one for each amplifier, so that one channel can be muted without muting the other if the application requires such a configuration. Refer to the [Typical Performance Characteristics](#) section for curves concerning Mute Attenuation vs Mute Pin Voltage.

### STANDBY MODE

The standby mode of the LM4730 allows the user to drastically reduce power consumption when the amplifiers are idle. By placing a logic-high voltage on the standby pins, the amplifiers will go into Standby Mode. In this mode, the current drawn from the  $V_{CC}$  supply is typically less than 10  $\mu$ A total for both amplifiers. The current drawn from the  $V_{EE}$  supply is typically 3.5mA. Clearly, there is a significant reduction in idle power consumption when using the standby mode. There are two Standby pins, so that one channel can be put in standby mode without putting the other amplifier in standby if the application requires such flexibility. Refer to the [Typical Performance Characteristics](#) section for curves showing Supply Current vs. Standby Pin Voltage for both supplies.

### UNDER-VOLTAGE PROTECTION

Upon system power-up, the under-voltage protection circuitry allows the power supplies and their corresponding capacitors to come up close to their full values before turning on the LM4730 such that no DC output spikes occur. Upon turn-off, the output of the LM4730 is brought to ground before the power supplies such that no transients occur at power-down.

### OVER-VOLTAGE PROTECTION

The LM4730 contains over-voltage protection circuitry that limits the output current while also providing voltage clamping, though not through internal clamping diodes. The clamping effect is quite the same, however, the output transistors are designed to work alternately by sinking large current spikes.

### THERMAL PROTECTION

The LM4730 has a sophisticated thermal protection scheme to prevent long-term thermal stress of the device. When the temperature on the die exceeds 150°C, the LM4730 shuts down. It starts operating again when the die temperature drops to about 145°C, but if the temperature again begins to rise, shutdown will occur again above 150°C. Therefore, the device is allowed to heat up to a relatively high temperature if the fault condition is temporary, but a sustained fault will cause the device to cycle in a Schmitt Trigger fashion between the thermal shutdown temperature limits of 150°C and 145°C. This greatly reduces the stress imposed on the IC by thermal cycling, which in turn improves its reliability under sustained fault conditions.

Since the die temperature is directly dependent upon the heat sink used, the heat sink should be chosen such that thermal shutdown will not be reached during normal operation. Using the best heat sink possible within the cost and space constraints of the system will improve the long-term reliability of any power semiconductor device, as discussed in the [Determining the Correct Heat Sink](#) Section.

### DETERMINING MAXIMUM POWER DISSIPATION

Power dissipation within the integrated circuit package is a very important parameter requiring a thorough understanding if optimum power output is to be obtained. An incorrect maximum power dissipation calculation may result in inadequate heat sinking causing thermal shutdown and thus limiting the output power.

[Equation 1](#) exemplifies the theoretical maximum power dissipation point of each amplifier where  $V_{CC}$  is the total supply voltage.

$$P_{DMAX} = V_{CC}^2 / 2\pi^2 R_L \quad (1)$$

Thus by knowing the total supply voltage and rated output load, the maximum power dissipation point can be calculated. The package dissipation is twice the number which results from [Equation 1](#) since there are two amplifiers in each LM4730. Refer to the graphs of Power Dissipation versus Output Power in the [Typical Performance Characteristics](#) section which show the actual full range of power dissipation not just the maximum theoretical point that results from [Equation 1](#).

## DETERMINING THE CORRECT HEAT SINK

The choice of a heat sink for a high-power audio amplifier is made entirely to keep the die temperature at a level such that the thermal protection circuitry does not operate under normal circumstances.

The thermal resistance from the die (junction) to the outside air (ambient) is a combination of three thermal resistances,  $\theta_{JC}$ ,  $\theta_{CS}$ , and  $\theta_{SA}$ . In addition, the thermal resistance,  $\theta_{JC}$  (junction to case), of the LM4730TA is 1.5°C/W. Using Thermalloy Thermacote thermal compound, the thermal resistance,  $\theta_{CS}$  (case to sink), is about 0.2°C/W. Since convection heat flow (power dissipation) is analogous to current flow, thermal resistance is analogous to electrical resistance, and temperature drops are analogous to voltage drops, the power dissipation out of the LM4730 is equal to the following:

$$P_{DMAX} = (T_{JMAX} - T_{AMB}) / \theta_{JA}$$

where

- $T_{JMAX} = 150^{\circ}\text{C}$
- $T_{AMB}$  is the system ambient temperature
- $\theta_{JA} = \theta_{JC} + \theta_{CS} + \theta_{SA}$  (2)

Once the maximum package power dissipation has been calculated using [Equation 1](#), the maximum thermal resistance,  $\theta_{SA}$ , (heat sink to ambient) in °C/W for a heat sink can be calculated. This calculation is made using [Equation 3](#) which is derived by solving for  $\theta_{SA}$  in [Equation 2](#).

$$\theta_{SA} = [(T_{JMAX} - T_{AMB}) - P_{DMAX}(\theta_{JC} + \theta_{CS})] / P_{DMAX} \quad (3)$$

Again it must be noted that the value of  $\theta_{SA}$  is dependent upon the system designer's amplifier requirements. If the ambient temperature that the audio amplifier is to be working under is higher than 25°C, then the thermal resistance for the heat sink, given all other things are equal, will need to be smaller.

## SUPPLY BYPASSING

The LM4730 has excellent power supply rejection and does not require a regulated supply. However, to improve system performance as well as eliminate possible oscillations, the LM4730 should have its supply leads bypassed with low-inductance capacitors having short leads that are located close to the package terminals. Inadequate power supply bypassing will manifest itself by a low frequency oscillation known as “motorboating” or by high frequency instabilities. These instabilities can be eliminated through multiple bypassing utilizing a large tantalum or electrolytic capacitor (10 µF or larger) which is used to absorb low frequency variations and a small ceramic capacitor (0.1 µF) to prevent any high frequency feedback through the power supply lines.

If adequate bypassing is not provided, the current in the supply leads which is a rectified component of the load current may be fed back into internal circuitry. This signal causes distortion at high frequencies requiring that the supplies be bypassed at the package terminals with an electrolytic capacitor of 470 µF or more.

## BRIDGED AMPLIFIER APPLICATION

The LM4730 has two operational amplifiers internally, allowing for a few different amplifier configurations. One of these configurations is referred to as “bridged mode” and involves driving the load differentially through the LM4730's outputs. This configuration is shown in [Figure 4](#). Bridged mode operation is different from the classical single-ended amplifier configuration where one side of its load is connected to ground.

A bridge amplifier design has a distinct advantage over the single-ended configuration, as it provides differential drive to the load, thus doubling output swing for a specified supply voltage. Consequently, theoretically four times the output power is possible as compared to a single-ended amplifier under the same conditions. This increase in attainable output power assumes that the amplifier is not current limited or clipped.

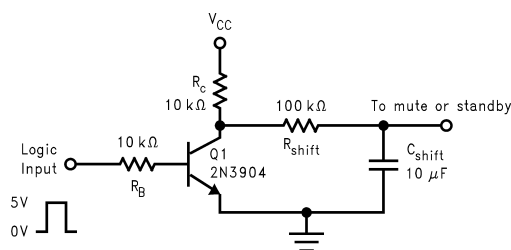
A direct consequence of the increased power delivered to the load by a bridge amplifier is an increase in internal power dissipation. For each operational amplifier in a bridge configuration, the internal power dissipation will increase by a factor of two over the single ended dissipation. Thus, for an audio power amplifier such as the LM4730, which has two operational amplifiers in one package, the package dissipation will increase by a factor of four. To calculate the LM4730's maximum power dissipation point for a bridged load, multiply [Equation 1](#) by a factor of four.

This value of  $P_{DMAX}$  can be used to calculate the correct size heat sink for a bridged amplifier application. Since the internal dissipation for a given power supply and load is increased by using bridged-mode, the heatsink's  $\theta_{SA}$  will have to decrease accordingly as shown by [Equation 3](#). Refer to the section, [Determining the Correct Heat Sink](#), for a more detailed discussion of proper heat sinking for a given application.

## SINGLE-SUPPLY AMPLIFIER APPLICATION

The typical application of the LM4730 is a split supply amplifier. But as shown in [Figure 5](#), the LM4730 can also be used in a single power supply configuration. This involves using some external components to create a half-supply bias which is used as the reference for the inputs and outputs. Thus, the signal will swing around half-supply much like it swings around ground in a split-supply application. Along with proper circuit biasing, a few other considerations must be accounted for to take advantage of all of the LM4730 functions.

The LM4730 possesses a mute and standby function with internal logic gates that are half-supply referenced. Thus, to enable either the Mute or Standby function, the voltage at these pins must be a minimum of 2.5V above half-supply. In single-supply systems, devices such as microprocessors and simple logic circuits used to control the mute and standby functions, are usually referenced to ground, not half-supply. Thus, to use these devices to control the logic circuitry of the LM4730, a "level shifter," like the one shown in [Figure 22](#), must be employed. A level shifter is not needed in a split-supply configuration since ground is also half-supply.



**Figure 22. Level Shift Circuit**

When the voltage at the Logic Input node is 0V, the 2N3904 is "off" and thus resistor  $R_C$  pulls up mute or standby input to the supply. This enables the mute or standby function. When the Logic Input is 5V, the 2N3904 is "on" and consequently, the voltage at the collector is essentially 0V. This will disable the mute or standby function, and thus the amplifier will be in its normal mode of operation.  $R_{shift}$ , along with  $C_{shift}$ , creates an RC time constant that reduces transients when the mute or standby functions are enabled or disabled. Additionally,  $R_{shift}$  limits the current supplied by the internal logic gates of the LM4730 which insures device reliability. Refer to the [MUTE MODE](#) and [STANDBY MODE](#) sections in the [Application Information](#) section for a more detailed description of these functions.

## CLICKS AND POPS

In the typical application of the LM4730 as a split-supply audio power amplifier, the IC exhibits excellent "click" and "pop" performance when utilizing the mute and standby modes. In addition, the device employs Under-Voltage Protection, which eliminates unwanted power-up and power-down transients. The basis for these functions are a stable and constant half-supply potential. In a split-supply application, ground is the stable half-supply potential. But in a single-supply application, the half-supply needs to charge up just like the supply rail,  $V_{CC}$ . This makes the task of attaining a clickless and popless turn-on more challenging. Any uneven charging of the amplifier inputs will result in output clicks and pops due to the differential input topology of the LM4730.

To achieve a transient free power-up and power-down, the voltage seen at the input terminals should be ideally the same. Such a signal will be common-mode in nature, and will be rejected by the LM4730. In [Figure 5](#), the resistor  $R_{INP}$  serves to keep the inputs at the same potential by limiting the voltage difference possible between the two nodes. This should significantly reduce any type of turn-on pop, due to an uneven charging of the amplifier inputs. This charging is based on a specific application loading and thus, the system designer may need to adjust these values for optimal performance.

As shown in [Figure 5](#), the resistors labeled  $R_{BI}$  help bias up the LM4730 off the half-supply node at the emitter of the 2N3904. But due to the input and output coupling capacitors in the circuit, along with the negative feedback, there are two different values of  $R_{BI}$ , namely 10 k $\Omega$  and 200 k $\Omega$ . These resistors bring up the inputs at the same rate resulting in a popless turn-on. Adjusting these resistors values slightly may reduce pops resulting from power supplies that ramp extremely quick or exhibit overshoot during system turn-on.

## PROPER SELECTION OF EXTERNAL COMPONENTS

Proper selection of external components is required to meet the design targets of an application. The choice of external component values that will affect gain and low frequency response are discussed below.

The gain of each amplifier is set by resistors  $R_f$  and  $R_i$  for the non-inverting configuration shown in [Figure 3](#). The gain is found by [Equation 4](#) below:

$$A_V = 1 + R_f / R_i \text{ (V/V)} \quad (4)$$

For best noise performance, lower values of resistors are used. A value of 1k $\Omega$  is commonly used for  $R_i$  and then setting the value of  $R_f$  for the desired gain. For the LM4730 the gain should be set no lower than 10V/V and no higher than 50V/V. Gain settings below 10V/V may experience instability and using the LM4730 for gains higher than 50V/V will see an increase in noise and THD.

The combination of  $R_i$  with  $C_i$  (see [Figure 3](#)) creates a high pass filter. The low frequency response is determined by these two components. The -3dB point can be found from [Equation 5](#) shown below:

$$f_i = 1 / (2\pi R_i C_i) \text{ (Hz)} \quad (5)$$

If an input coupling capacitor is used to block DC from the inputs as shown in [Figure 6](#), there will be another high pass filter created with the combination of  $C_{IN}$  and  $R_{IN}$ . When using a input coupling capacitor  $R_{IN}$  is needed to set the DC bias point on the amplifier's input terminal. The resulting -3dB frequency response due to the combination of  $C_{IN}$  and  $R_{IN}$  can be found from [Equation 6](#) shown below:

$$f_{IN} = 1 / (2\pi R_{IN} C_{IN}) \text{ (Hz)} \quad (6)$$

## PHYSICAL IC MOUNTING CONSIDERATIONS

Mounting of the TO-220 package to a heat sink must be done such that there is sufficient pressure from the mounting screw to insure good contact with the heat sink for efficient heat flow. Over tightening the mounting screw will cause the TO-220 package to warp reducing contact area with the heat sink. Less contact with the heat sink will increase the thermal resistance from the TO-220 package case to the heat sink ( $\theta_{CS}$ ) resulting in higher operating die temperatures and possible unwanted thermal shut down activation. Extreme over tightening of the mounting screw will cause severe physical stress resulting in cracked die and catastrophic IC failure. The recommended maximum mounting screw torque is 40 inch-lbs or 3.3 foot-lbs (4.5 newton-meter).

Additionally, if the mounting screw is used to force the TO-220 package into correct alignment with the heat sink, package stress will be increased. This increase in package stress will result in reduced contact area with the heat sink increasing die operating temperature and possible catastrophic IC failure.

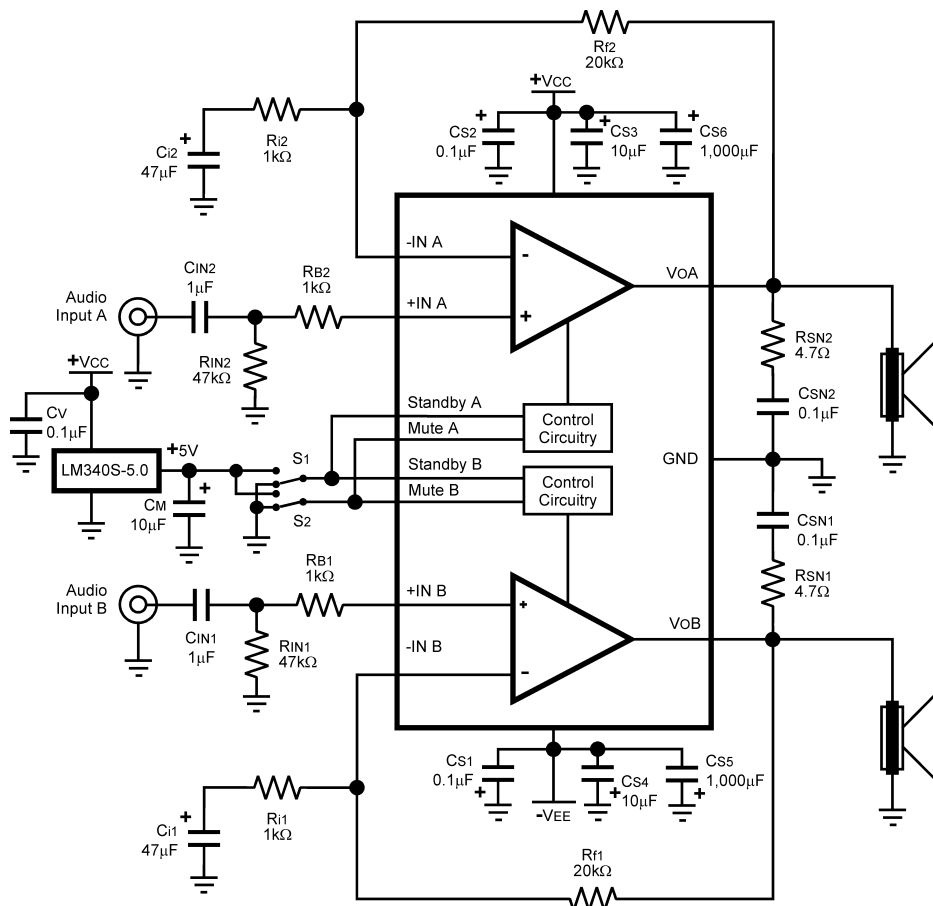


Figure 23. Reference PCB Schematic

LM4730 REFERENCE BOARD ARTWORK

Figure 24. Composite View

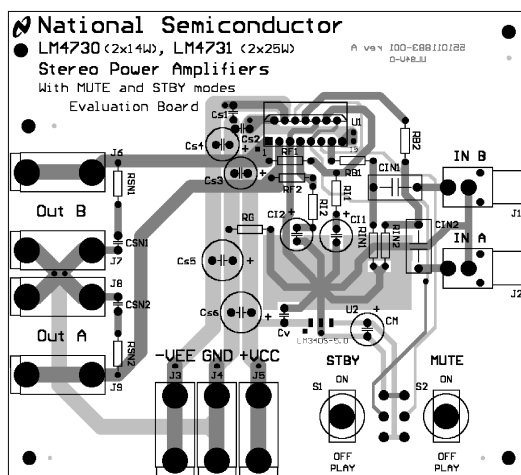


Figure 25. Silk Screen

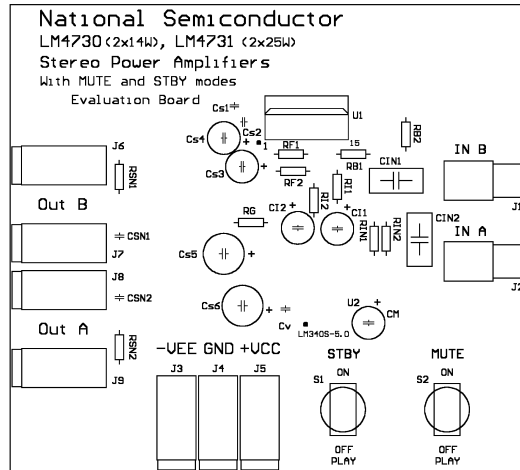


Figure 26. Top Layer

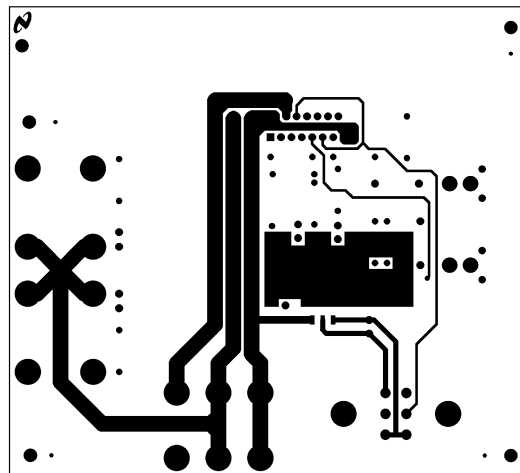
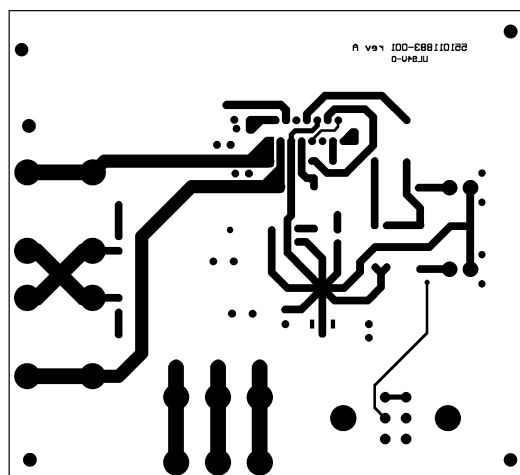


Figure 27. Bottom Layer



**Table 1. BILL OF MATERIALS FOR REFERENCE PCB**

Symbol	Value	Tolerance	Type/Description	Comments
R <sub>IN1</sub> , R <sub>IN2</sub>	47kΩ	5%	1/4 Watt	
R <sub>B1</sub> , R <sub>B2</sub>	1kΩ	1%	1/4 Watt	
R <sub>F1</sub> , R <sub>F2</sub>	20kΩ	1%	1/4 Watt	
R <sub>i1</sub> , R <sub>i2</sub>	1kΩ	1%	1/4 Watt	
R <sub>SN1</sub> , R <sub>SN2</sub>	4.7Ω	5%	1/4 Watt	
R <sub>G</sub>	2.7Ω	5%	1/4 Watt	
C <sub>IN1</sub> , C <sub>IN2</sub>	1μF	10%	Metallized Polyester Film	
C <sub>i1</sub> , C <sub>i2</sub>	47μF	20%	Electrolytic Radial / 35V	
C <sub>SN1</sub> , C <sub>SN2</sub>	0.1μF	20%	Monolithic Ceramic	
C <sub>V</sub>	0.1μF	20%	Monolithic Ceramic	
C <sub>M</sub>	10μF	20%	Electrolytic Radial / 16V	
C <sub>S1</sub> , C <sub>S2</sub>	0.1μF	20%	Monolithic Ceramic	
C <sub>S3</sub> , C <sub>S4</sub>	10μF	20%	Electrolytic Radial / 35V	
C <sub>S5</sub> , C <sub>S6</sub>	1,000μF	20%	Electrolytic Radial / 35V	
S <sub>1</sub> , S <sub>2</sub>			SPDT (on-on) Switch	
J <sub>1</sub> , J <sub>2</sub>			Non-switched PC Mount RCA Jack	
J <sub>4</sub> , J <sub>7</sub> , J <sub>8</sub>			PCB Banana Jack- BLACK	
J <sub>3</sub> , J <sub>5</sub> , J <sub>6</sub> , J <sub>9</sub>			PCB Banana Jack- RED	
U <sub>1</sub>			15 lead TO-220 Power Socket	
U <sub>2</sub>			LM340, 5V Fixed Regulator, TO-263 package (TS3B)	

**REVISION HISTORY**

<b>Changes from Revision B (April 2013) to Revision C</b>	<b>Page</b>
• Changed layout of National Data Sheet to TI format .....	<a href="#">15</a>

## IMPORTANT NOTICE

Texas Instruments Incorporated and its subsidiaries (TI) reserve the right to make corrections, enhancements, improvements and other changes to its semiconductor products and services per JESD46, latest issue, and to discontinue any product or service per JESD48, latest issue. Buyers should obtain the latest relevant information before placing orders and should verify that such information is current and complete. All semiconductor products (also referred to herein as "components") are sold subject to TI's terms and conditions of sale supplied at the time of order acknowledgment.

TI warrants performance of its components to the specifications applicable at the time of sale, in accordance with the warranty in TI's terms and conditions of sale of semiconductor products. Testing and other quality control techniques are used to the extent TI deems necessary to support this warranty. Except where mandated by applicable law, testing of all parameters of each component is not necessarily performed.

TI assumes no liability for applications assistance or the design of Buyers' products. Buyers are responsible for their products and applications using TI components. To minimize the risks associated with Buyers' products and applications, Buyers should provide adequate design and operating safeguards.

TI does not warrant or represent that any license, either express or implied, is granted under any patent right, copyright, mask work right, or other intellectual property right relating to any combination, machine, or process in which TI components or services are used. Information published by TI regarding third-party products or services does not constitute a license to use such products or services or a warranty or endorsement thereof. Use of such information may require a license from a third party under the patents or other intellectual property of the third party, or a license from TI under the patents or other intellectual property of TI.

Reproduction of significant portions of TI information in TI data books or data sheets is permissible only if reproduction is without alteration and is accompanied by all associated warranties, conditions, limitations, and notices. TI is not responsible or liable for such altered documentation. Information of third parties may be subject to additional restrictions.

Resale of TI components or services with statements different from or beyond the parameters stated by TI for that component or service voids all express and any implied warranties for the associated TI component or service and is an unfair and deceptive business practice. TI is not responsible or liable for any such statements.

Buyer acknowledges and agrees that it is solely responsible for compliance with all legal, regulatory and safety-related requirements concerning its products, and any use of TI components in its applications, notwithstanding any applications-related information or support that may be provided by TI. Buyer represents and agrees that it has all the necessary expertise to create and implement safeguards which anticipate dangerous consequences of failures, monitor failures and their consequences, lessen the likelihood of failures that might cause harm and take appropriate remedial actions. Buyer will fully indemnify TI and its representatives against any damages arising out of the use of any TI components in safety-critical applications.

In some cases, TI components may be promoted specifically to facilitate safety-related applications. With such components, TI's goal is to help enable customers to design and create their own end-product solutions that meet applicable functional safety standards and requirements. Nonetheless, such components are subject to these terms.

No TI components are authorized for use in FDA Class III (or similar life-critical medical equipment) unless authorized officers of the parties have executed a special agreement specifically governing such use.

Only those TI components which TI has specifically designated as military grade or "enhanced plastic" are designed and intended for use in military/aerospace applications or environments. Buyer acknowledges and agrees that any military or aerospace use of TI components which have **not** been so designated is solely at the Buyer's risk, and that Buyer is solely responsible for compliance with all legal and regulatory requirements in connection with such use.

TI has specifically designated certain components as meeting ISO/TS16949 requirements, mainly for automotive use. In any case of use of non-designated products, TI will not be responsible for any failure to meet ISO/TS16949.

### Products

Audio	<a href="http://www.ti.com/audio">www.ti.com/audio</a>
Amplifiers	<a href="http://amplifier.ti.com">amplifier.ti.com</a>
Data Converters	<a href="http://dataconverter.ti.com">dataconverter.ti.com</a>
DLP® Products	<a href="http://www.dlp.com">www.dlp.com</a>
DSP	<a href="http://dsp.ti.com">dsp.ti.com</a>
Clocks and Timers	<a href="http://www.ti.com/clocks">www.ti.com/clocks</a>
Interface	<a href="http://interface.ti.com">interface.ti.com</a>
Logic	<a href="http://logic.ti.com">logic.ti.com</a>
Power Mgmt	<a href="http://power.ti.com">power.ti.com</a>
Microcontrollers	<a href="http://microcontroller.ti.com">microcontroller.ti.com</a>
RFID	<a href="http://www.ti-rfid.com">www.ti-rfid.com</a>
OMAP Applications Processors	<a href="http://www.ti.com/omap">www.ti.com/omap</a>
Wireless Connectivity	<a href="http://www.ti.com/wirelessconnectivity">www.ti.com/wirelessconnectivity</a>

### Applications

Automotive and Transportation	<a href="http://www.ti.com/automotive">www.ti.com/automotive</a>
Communications and Telecom	<a href="http://www.ti.com/communications">www.ti.com/communications</a>
Computers and Peripherals	<a href="http://www.ti.com/computers">www.ti.com/computers</a>
Consumer Electronics	<a href="http://www.ti.com/consumer-apps">www.ti.com/consumer-apps</a>
Energy and Lighting	<a href="http://www.ti.com/energy">www.ti.com/energy</a>
Industrial	<a href="http://www.ti.com/industrial">www.ti.com/industrial</a>
Medical	<a href="http://www.ti.com/medical">www.ti.com/medical</a>
Security	<a href="http://www.ti.com/security">www.ti.com/security</a>
Space, Avionics and Defense	<a href="http://www.ti.com/space-avionics-defense">www.ti.com/space-avionics-defense</a>
Video and Imaging	<a href="http://www.ti.com/video">www.ti.com/video</a>

### TI E2E Community

[e2e.ti.com](http://e2e.ti.com)

## Looking for pricing, stock, or lifecycle information?

Click below to explore more details on WIN SOURCE:

 [View LM4730TA](#) on WIN SOURCE

 [Texas Instruments](#) Information

## Optimize Your Supply Chain with WIN SOURCE Solutions

-  Global Sourcing Solution
-  Obsolete Management
-  Cost Control Management
-  Shortage Management
-  Alternative Solution
-  Excess Inventory Management