



**THE DATASHEET OF  
LM4570LQ/NOPB**



## LM4570 Single-Ended Input Motor Driver

Check for Samples: [LM4570](#)

### FEATURES

- Output Short Circuit Protection
- High Output Current Capability
- Wide Output Voltage Range
- Fast Turn on Time
- Output Short Circuit Protection
- Low Power Shutdown Mode
- Minimum External Components
- Available in Space-Saving WSON Package

### APPLICATIONS

- Mobile Phones
- PDAs
- Video Game Systems

### KEY SPECIFICATIONS

- High Output Current @  $V_{DD} = 3V$ : 192 mA
- Fast Turn On Time @ 3V: 2.4 ms
- Quiescent Power Supply Current @ 3V: 1.9 mA
- Shutdown Current: 0.1  $\mu A$  (Typ)

### Typical Application

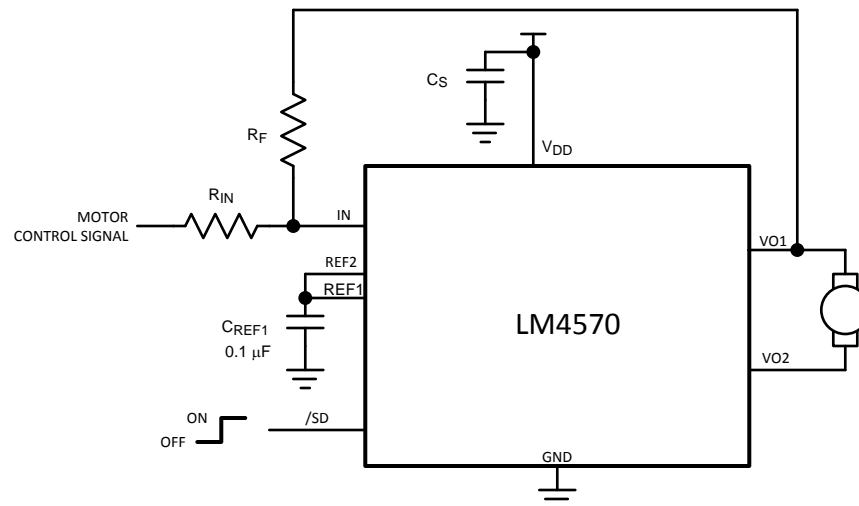

**Figure 1. Typical Motor Driver Application Circuit**

### DESCRIPTION

The LM4570 is a single supply motor driver for improved sensory experience in mobile phones and other handheld devices. The LM4570 is capable of driving up to 192mA while operating from a 3V supply. Near rail-to-rail output swing under load ensures sufficient voltage drive for most DC motors, while the differential output drive allows the voltage polarity across the motor to be reversed quickly. Reversing the voltage gives the LM4570 the ability to drive a motor both clock-wise and counter clock-wise from a single supply.

The LM4570 features fast turn on time, and a wide input voltage range for precise speed control. A low power shutdown mode minimizes power consumption.

Thermal and output short circuit protection prevents the device from being damaged during fault conditions.



Please be aware that an important notice concerning availability, standard warranty, and use in critical applications of Texas Instruments semiconductor products and disclaimers thereto appears at the end of this data sheet.

All trademarks are the property of their respective owners.

PRODUCTION DATA information is current as of publication date. Products conform to specifications per the terms of the Texas Instruments standard warranty. Production processing does not necessarily include testing of all parameters.

Copyright © 2006–2013, Texas Instruments Incorporated

## Connection Diagram

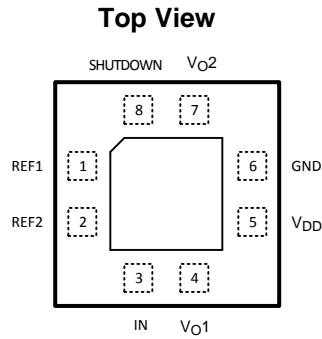

**Figure 2. Leadless Leadframe WSON Package**  
See Package Number NGP0008A



These devices have limited built-in ESD protection. The leads should be shorted together or the device placed in conductive foam during storage or handling to prevent electrostatic damage to the MOS gates.

### Absolute Maximum Ratings<sup>(1)(2)</sup>

Supply Voltage <sup>(3)</sup>		6.0V
Storage Temperature		-65°C to +150°C
Voltage at Any Input Pin		-0.3V $\geq$ to $V_{DD} + 0.3V$
Power Dissipation <sup>(4)</sup>		Internally Limited
ESD Susceptibility <sup>(5)</sup>		2000V
ESD Susceptibility <sup>(6)</sup>		200V
Junction Temperature ( $T_{JMAX}$ )		150°C
Thermal Resistance	$\theta_{JA}$ (WSON)	140°C/W

- (1) Absolute Maximum Ratings indicate limits beyond which damage to the device may occur. Operating Ratings indicate conditions for which the device is functional, but do not specify specific performance limits. Electrical Characteristics state DC and AC electrical specifications under particular test conditions which specify specific performance limits. This assumes that the device is within the Operating Ratings. Specifications are not specified for parameters where no limit is given; however, the typical value is a good indication of device performance.
- (2) If Military/Aerospace specified devices are required, please contact the Texas Instruments Sales Office/Distributors for availability and specifications.
- (3) All voltages are measured with respect to the ground pin, unless otherwise specified.
- (4) The maximum power dissipation must be de-rated at elevated temperatures and is dictated by  $T_{JMAX}$ ,  $\theta_{JC}$ , and the ambient temperature  $T_A$ . The maximum allowable power dissipation is  $P_{DMAX} = (T_{JMAX} - T_A) / \theta_{JA}$  or the number given in the Absolute Maximum Ratings, whichever is lower. For the LM4570,  $T_{JMAX} = 150^\circ\text{C}$  and the typical  $\theta_{JA}$  for the WSON package is 140°C/W.
- (5) Human body model, 100pF discharged through a 1.5k $\Omega$  resistor.
- (6) Machine Model, 220pF–240pF discharged through all pins.

### Operating Ratings

Temperature Range ( $T_{MIN} \leq T_A \leq T_{MAX}$ )		-40°C $\leq T_A \leq$ 85°C
Supply Voltage		2.4V $\leq V_{DD} \leq$ 5.5V

## Electrical Characteristics $V_{DD} = 5V$

(1)(2)

 The following specifications apply for  $V_{DD} = 5V$ ,  $A_{V-BTL} = 6dB$  unless otherwise specified. Limits apply for  $T_A = 25^\circ C$ .

Parameter	Test Conditions	LM4570		Units (Limits)	
		Typ <sup>(3)</sup>	Limit <sup>(4)(5)</sup>		
$I_{DD}$	Quiescent Power Supply Current	$V_{IN} = 0V, I_L = 0A$ , No Load	2.5	5.5	mA (max)
		$V_{IN} = 0V, I_L = 0A, R_L = 30\Omega$	2.6	5.5	mA (max)
$I_{SD}$	Shutdown Current	$V_{SD} = GND$	0.1	1.5	$\mu A$ (max)
$V_{IH}$	Logic Input High			1.4	V (min)
$V_{IL}$	Logic Input Low			0.4	V (max)
$V_{OS}$	Output Offset Voltage		5	$\pm 35$	mV (max)
$I_{OUT}$	Output Current	$V_{OH}, V_{OL} \leq 250mV$	268		mA
$T_{WU}$	Wake-up time		2.5		ms (max)
$V_{OH}$	Output High Voltage	$R_L = 30\Omega$ specified as $ V_{DD} - V_{OH} $	146	200	mV (max)
$V_{OL}$	Output Low Voltage	$R_L = 30\Omega$ specified as $ GND + V_{OH} $	106	200	mV (max)

- All voltages are measured with respect to the ground pin, unless otherwise specified.
- Absolute Maximum Ratings indicate limits beyond which damage to the device may occur. Operating Ratings indicate conditions for which the device is functional, but do not specify specific performance limits. Electrical Characteristics state DC and AC electrical specifications under particular test conditions which specify specific performance limits. This assumes that the device is within the Operating Ratings. Specifications are not specified for parameters where no limit is given; however, the typical value is a good indication of device performance.
- Typicals are measured at  $25^\circ C$  and represent the parametric norm.
- Limits are ensured to AOQL (Average Outgoing Quality Level).
- Datasheet min/max specification limits are ensured by design, test, or statistical analysis.

## Electrical Characteristics $V_{DD} = 3V$

(1)(2)

 The following specifications apply for  $V_{DD} = 3V$ ,  $A_{V-BTL} = 6dB$  unless otherwise specified. Limits apply for  $T_A = 25^\circ C$ .

Parameter	Test Conditions	LM4570		Units (Limits)	
		Typ <sup>(3)</sup>	Limit <sup>(4)(5)</sup>		
$I_{DD}$	Quiescent Power Supply Current	$V_{IN} = 0V, I_L = 0A$ , No Load	1.9	4	mA (max)
		$V_{IN} = 0V, I_L = 0A, R_L = 30\Omega$	1.95	4	
$I_{SD}$	Shutdown Current <sup>(6)</sup>	$V_{SD} = GND$	0.1	1.0	$\mu A$ (max)
$V_{IH}$	Logic Input High			1.4	V (min)
$V_{IL}$	Logic Input Low			0.4	V (max)
$V_{OS}$	Output Offset Voltage		5	$\pm 35$	mV (max)
$I_{OUT}$	Output Current	$V_{OH}, V_{OL} \leq 200mV$	192		mA
$T_{WU}$	Wake-up time		2.4		ms (max)
$V_{OH}$	Output High Voltage	$R_L = 30\Omega$ specified as $ V_{DD} - V_{OH} $	90	110	mV (max)
$V_{OL}$	Output Low Voltage	$R_L = 30\Omega$ specified as $ V_{DD} - V_{OH} $	63	110	mV (max)

- All voltages are measured with respect to the ground pin, unless otherwise specified.
- Absolute Maximum Ratings indicate limits beyond which damage to the device may occur. Operating Ratings indicate conditions for which the device is functional, but do not specify specific performance limits. Electrical Characteristics state DC and AC electrical specifications under particular test conditions which specify specific performance limits. This assumes that the device is within the Operating Ratings. Specifications are not specified for parameters where no limit is given; however, the typical value is a good indication of device performance.
- Typicals are measured at  $25^\circ C$  and represent the parametric norm.
- Limits are ensured to AOQL (Average Outgoing Quality Level).
- Datasheet min/max specification limits are ensured by design, test, or statistical analysis.
- Shutdown current is measured in a normal room environment. Exposure to direct sunlight will increase  $I_{SD}$  by a maximum of  $2\mu A$ .

Typical Performance Characteristics

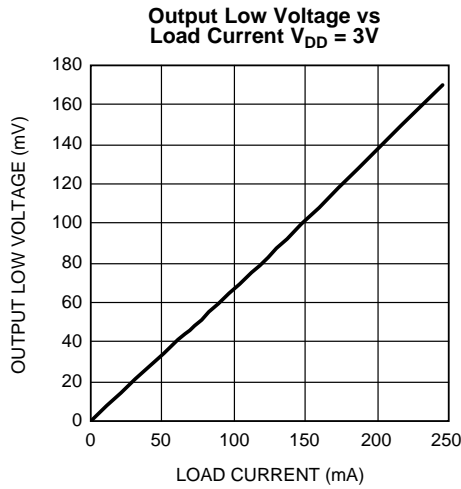

Figure 3.

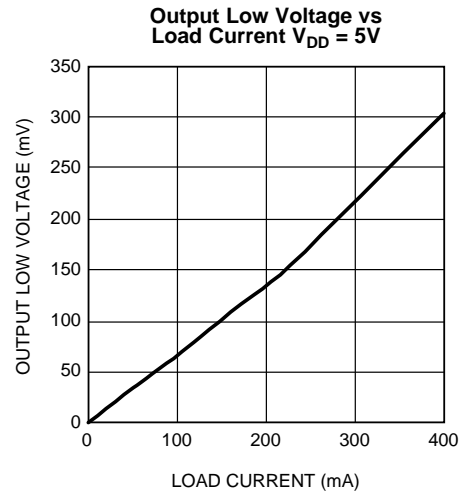

Figure 4.

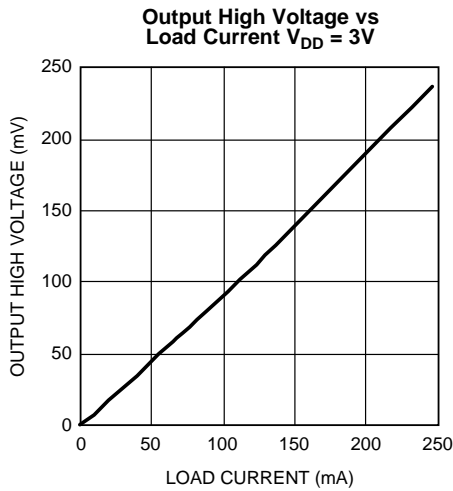

Figure 5.

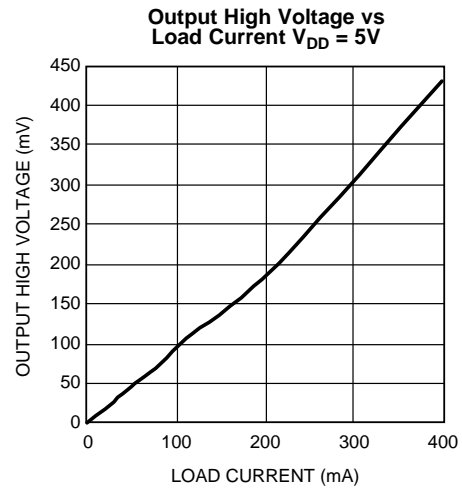

Figure 6.

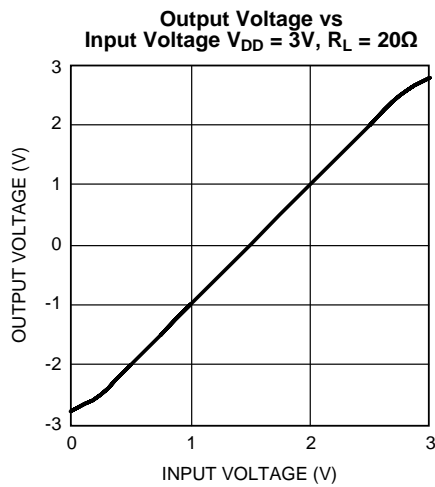

Figure 7.

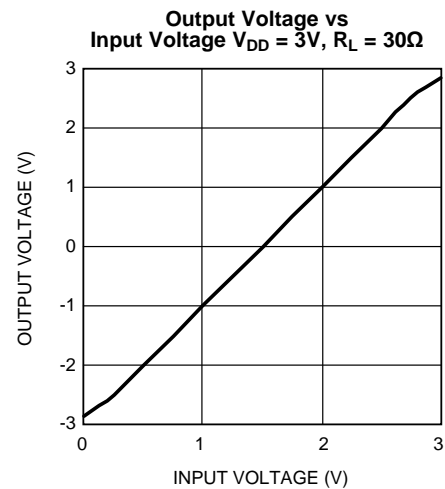

Figure 8.

Typical Performance Characteristics (continued)

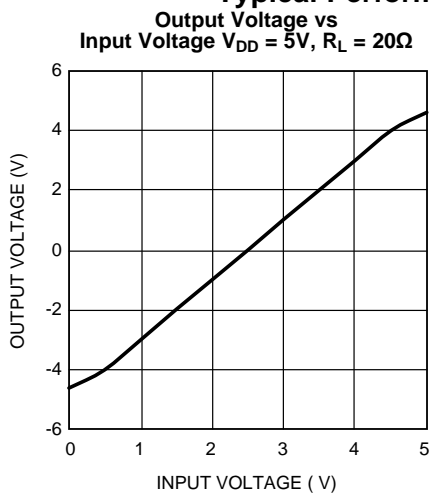

Figure 9.

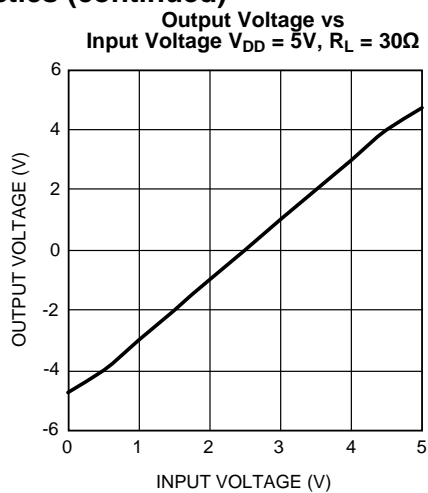

Figure 10.

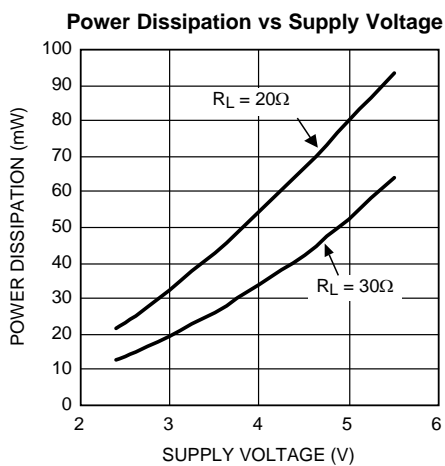

Figure 11.

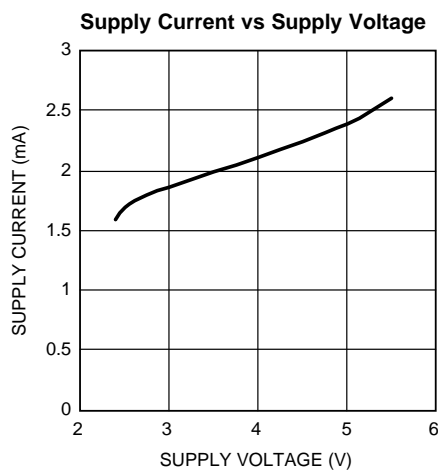

Figure 12.

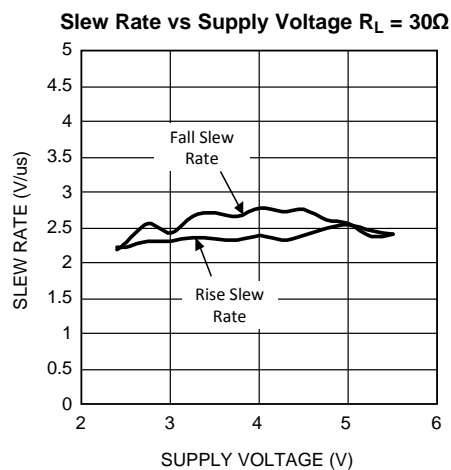

Figure 13.

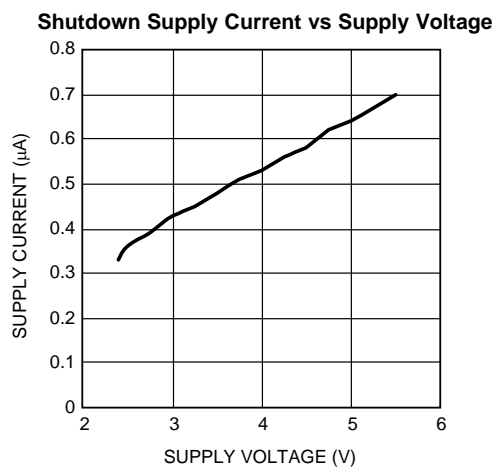

Figure 14.

**Typical Performance Characteristics (continued)**

Output Transition High to Low, Low to High  
 $V_{DD} = 3V$ , 1V/div, 400ns/div

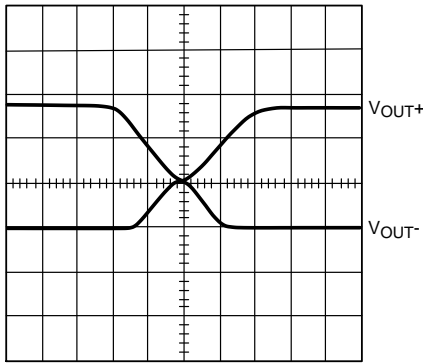

Figure 15.

Output Transition High to Low, Low to High  
 $V_{DD} = 5V$ , 1V/div, 1μs/div

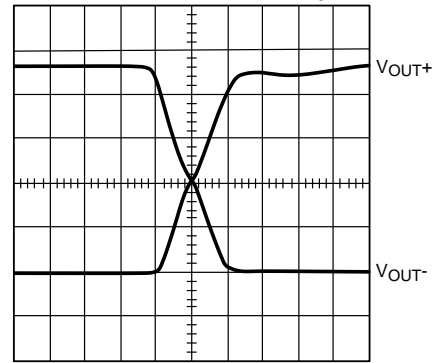

Figure 16.

Turn-Off Time  $V_{DD} = 5V$ , 2V/div, 1ms/div

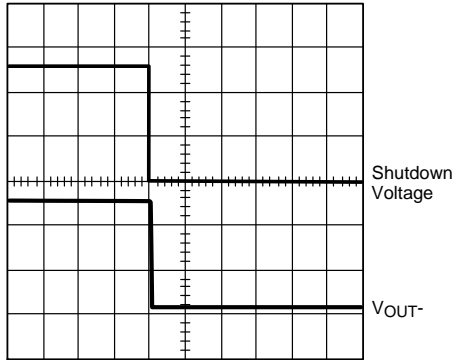

Figure 17.

Turn-On Time  $V_{DD} = 5V$ , 2V/div, 1ms/div

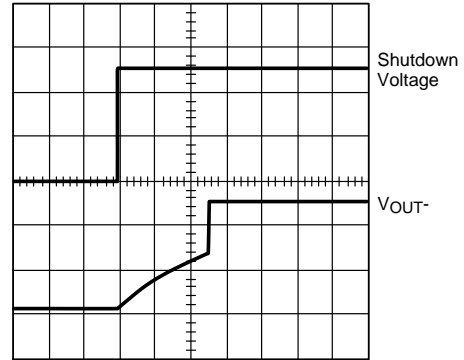

Figure 18.

## APPLICATION INFORMATION

### BRIDGE CONFIGURATION EXPLANATION

The LM4570 uses a bridged architecture that drives a load differentially. The BTL design offers several advantages over a single-ended design. The device outputs,  $V_{O1}$  and  $V_{O2}$ , both source and sink current, which means that the polarity of the voltage across the motor can be reversed quickly (Figure 19). A single-ended device would need to operate from split supplies to achieve this behavior. The ability to reverse the voltage polarity is necessary in applications where a negative (reverse polarity) pulse is used to quickly stop the motor. If the drive voltage is just removed from the motor (not reversed) then the motor will continue to spin until the residual energy stored in the windings has dissipated.

The output voltage of the LM4570 is determined by the difference between the input voltage and  $V_{REF1}$ , as well as the differential gain of the device. The output voltage is given by the following:

$$V_{O1} - V_{O2} = A_{VD}(V_{IN} - V_{REF1}) \quad (1)$$

For input voltages that are less than the reference voltage, the differential output voltage is negative. For input voltages that are greater than the reference voltage, the differential output voltage is positive. For example, when operating from a 5V supply ( $V_{REF1} = 2.5V$ ) and with a differential gain of 6dB, with a 1V input, the voltage measured across  $V_{O1}$  and  $V_{O2}$  is -3V, with a 4V input, the differential output voltage is +3V.

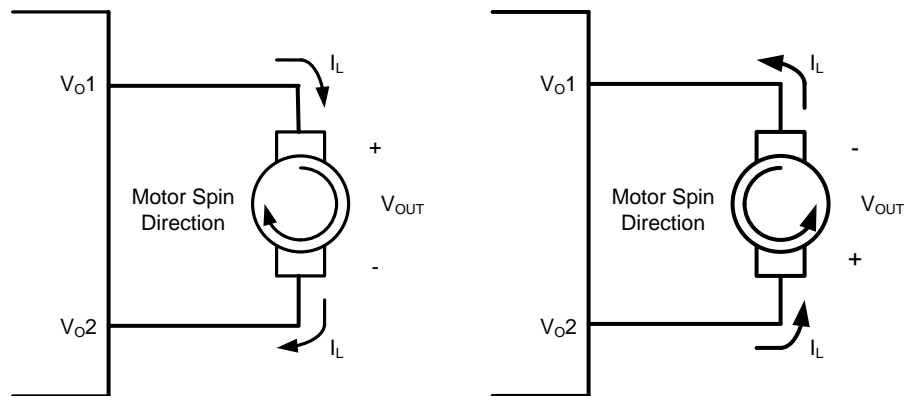

Figure 19. Voltage Polarity and Motor Direction

### GAIN SETTING

The resistors  $R_{IN}$  and  $R_F$  set the gain of the LM4570, given by:

$$V_{VD} = 2 \times (R_F / R_{IN}) \quad (2)$$

Where  $A_{VD}$  is the differential gain.  $A_{VD}$  differs from single-ended gain by a factor of 2. This doubling is due to the differential output architecture of the LM4570. Driving the load differentially doubles the output voltage compared to a single-ended output amplifier under the same conditions.

### POWER DISSIPATION

Figure 11 shows the power dissipation of the LM4570 with the input equal to the supply voltage, meaning the outputs swing rail-to-rail. This configuration results in the output devices of the LM4570 operating in the linear region, essentially very small resistors determined by the  $R_{DS(ON)}$  of the output devices. Under these conditions, the power dissipation is dominated by the  $I^2R$  drop associated with the output current across the  $R_{DS(ON)}$  of the output transistors, thus the power dissipation is very low (60mW for a 800mW output).

When the input voltage is not equal to GND or  $V_{DD}$ , the power dissipation of the LM4570 increases (Figure 20). Under these conditions, the output devices operate in the saturation region, where the devices consume current in addition to the current being steered to the load, increasing the power dissipation. Power dissipation for typical motor driving applications should not be an issue since the most of the time the device outputs will be driven rail-to-rail.

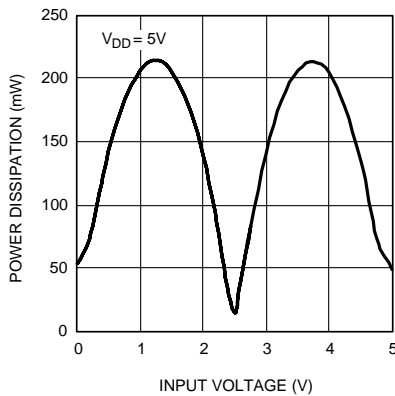

**Figure 20. Power Dissipation vs. Input Voltage**

## EXPOSED-DAP MOUNTING CONSIDERATIONS

The LM4570 is available in an 8-pin WSON package which features an exposed DAP (die attach paddle). The exposed DAP provides a direct thermal conduction path between the die and the PCB, improving the thermal performance by reducing the thermal resistance of the package. Connect the exposed DAP to GND through a large pad beneath the device, and multiple vias to a large unbroken GND plane. For best thermal performance, connect the DAP pad to a GND plane on an outside layer of the PCB. Connecting the DAP to a plane on an inner layer will result in a higher thermal resistance. Ensure efficient thermal conductivity by plugging and tenting the vias with plating and solder mask, respectively.

## POWER SUPPLY BYPASSING

Good power supply bypassing is critical for proper operation. Locate both the REF1 and  $V_{DD}$  bypass capacitors as close to the device as possible. Typical applications employ a regulator with a 10 $\mu$ F tantalum or electrolytic capacitor and a ceramic bypass capacitor which aid in supply stability. This does not eliminate the need for bypass capacitors near the LM4570. Place a 1 $\mu$ F ceramic capacitor as close to  $V_{DD}$  as possible. Place a 0.1 $\mu$ F capacitor as close to REF1 as possible. Smaller values of  $C_{REF1}$  may be chosen for decreased turn on times.

## SHUTDOWN FUNCTION

The LM4570 features a low power shutdown mode that disables the device and reduces quiescent current consumption to 0.1 $\mu$ A. Driving /SD Low disables the amplifiers and bias circuitry, and drives  $V_{REF1}$  and the outputs to GND. Connect /SD to  $V_{DD}$  for normal operation.

DEMO BOARD LAYOUT

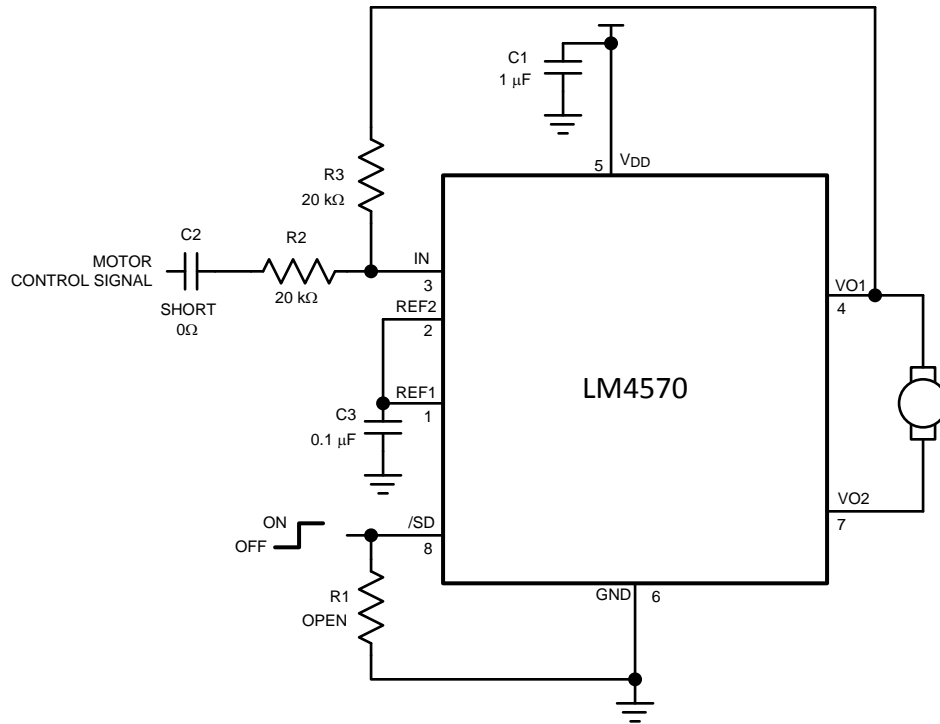

Revision History

Rev	Date	Description
1.0	04/13/06	Initial release.
1.01	07/28/09	Added the Ordering Information table.
C	04/08/13	Changed layout of National Data Sheet to TI format.

**PACKAGING INFORMATION**

Orderable Device	Status (1)	Package Type	Package Drawing	Pins	Package Qty	Eco Plan (2)	Lead/Ball Finish	MSL Peak Temp (3)	Op Temp (°C)	Device Marking (4/5)	Samples
LM4570LQ/NOPB	ACTIVE	WQFN	NGP	8	1000	Green (RoHS & no Sb/Br)	CU SN	Level-3-260C-168 HR	-40 to 85	GC8	Samples

(1) The marketing status values are defined as follows:

**ACTIVE:** Product device recommended for new designs.

**LIFEBUY:** TI has announced that the device will be discontinued, and a lifetime-buy period is in effect.

**NRND:** Not recommended for new designs. Device is in production to support existing customers, but TI does not recommend using this part in a new design.

**PREVIEW:** Device has been announced but is not in production. Samples may or may not be available.

**OBSOLETE:** TI has discontinued the production of the device.

(2) Eco Plan - The planned eco-friendly classification: Pb-Free (RoHS), Pb-Free (RoHS Exempt), or Green (RoHS & no Sb/Br) - please check <http://www.ti.com/productcontent> for the latest availability information and additional product content details.

**TBD:** The Pb-Free/Green conversion plan has not been defined.

**Pb-Free (RoHS):** TI's terms "Lead-Free" or "Pb-Free" mean semiconductor products that are compatible with the current RoHS requirements for all 6 substances, including the requirement that lead not exceed 0.1% by weight in homogeneous materials. Where designed to be soldered at high temperatures, TI Pb-Free products are suitable for use in specified lead-free processes.

**Pb-Free (RoHS Exempt):** This component has a RoHS exemption for either 1) lead-based flip-chip solder bumps used between the die and package, or 2) lead-based die adhesive used between the die and leadframe. The component is otherwise considered Pb-Free (RoHS compatible) as defined above.

**Green (RoHS & no Sb/Br):** TI defines "Green" to mean Pb-Free (RoHS compatible), and free of Bromine (Br) and Antimony (Sb) based flame retardants (Br or Sb do not exceed 0.1% by weight in homogeneous material)

(3) MSL, Peak Temp. -- The Moisture Sensitivity Level rating according to the JEDEC industry standard classifications, and peak solder temperature.

(4) There may be additional marking, which relates to the logo, the lot trace code information, or the environmental category on the device.

(5) Multiple Device Markings will be inside parentheses. Only one Device Marking contained in parentheses and separated by a "~" will appear on a device. If a line is indented then it is a continuation of the previous line and the two combined represent the entire Device Marking for that device.

**Important Information and Disclaimer:** The information provided on this page represents TI's knowledge and belief as of the date that it is provided. TI bases its knowledge and belief on information provided by third parties, and makes no representation or warranty as to the accuracy of such information. Efforts are underway to better integrate information from third parties. TI has taken and continues to take reasonable steps to provide representative and accurate information but may not have conducted destructive testing or chemical analysis on incoming materials and chemicals. TI and TI suppliers consider certain information to be proprietary, and thus CAS numbers and other limited information may not be available for release.

In no event shall TI's liability arising out of such information exceed the total purchase price of the TI part(s) at issue in this document sold by TI to Customer on an annual basis.

## TAPE AND REEL INFORMATION



### QUADRANT ASSIGNMENTS FOR PIN 1 ORIENTATION IN TAPE



\*All dimensions are nominal

Device	Package Type	Package Drawing	Pins	SPQ	Reel Diameter (mm)	Reel Width W1 (mm)	A0 (mm)	B0 (mm)	K0 (mm)	P1 (mm)	W (mm)	Pin1 Quadrant
LM4570LQ/NOPB	WQFN	NGP	8	1000	178.0	12.4	2.2	2.2	1.0	8.0	12.0	Q1

TAPE AND REEL BOX DIMENSIONS



\*All dimensions are nominal

Device	Package Type	Package Drawing	Pins	SPQ	Length (mm)	Width (mm)	Height (mm)
LM4570LQ/NOPB	WQFN	NGP	8	1000	210.0	185.0	35.0

NGP0008A

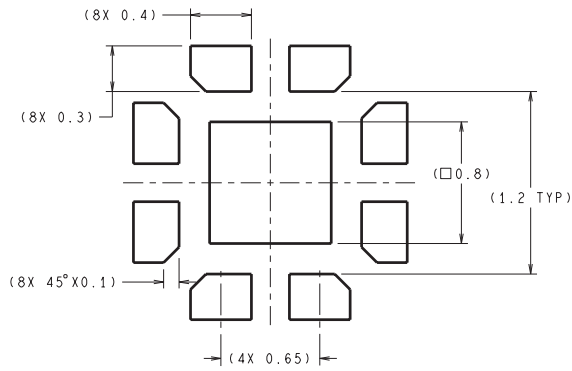

DIMENSIONS ARE IN MILLIMETERS

**RECOMMENDED LAND PATTERN**  
1:1 RATIO WITH PKG SOLDER PADS

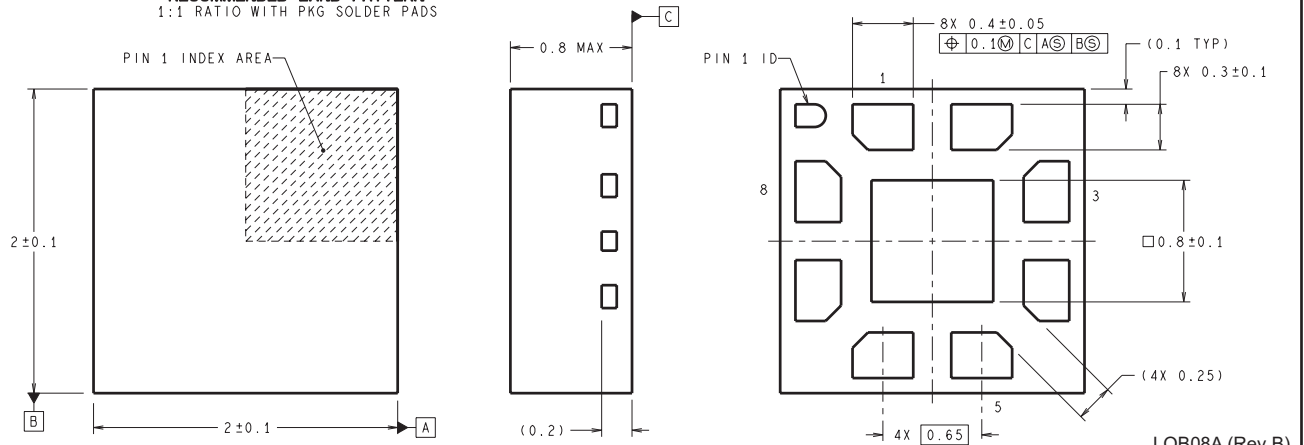

LQB08A (Rev B)

## IMPORTANT NOTICE

Texas Instruments Incorporated and its subsidiaries (TI) reserve the right to make corrections, enhancements, improvements and other changes to its semiconductor products and services per JESD46, latest issue, and to discontinue any product or service per JESD48, latest issue. Buyers should obtain the latest relevant information before placing orders and should verify that such information is current and complete. All semiconductor products (also referred to herein as "components") are sold subject to TI's terms and conditions of sale supplied at the time of order acknowledgment.

TI warrants performance of its components to the specifications applicable at the time of sale, in accordance with the warranty in TI's terms and conditions of sale of semiconductor products. Testing and other quality control techniques are used to the extent TI deems necessary to support this warranty. Except where mandated by applicable law, testing of all parameters of each component is not necessarily performed.

TI assumes no liability for applications assistance or the design of Buyers' products. Buyers are responsible for their products and applications using TI components. To minimize the risks associated with Buyers' products and applications, Buyers should provide adequate design and operating safeguards.

TI does not warrant or represent that any license, either express or implied, is granted under any patent right, copyright, mask work right, or other intellectual property right relating to any combination, machine, or process in which TI components or services are used. Information published by TI regarding third-party products or services does not constitute a license to use such products or services or a warranty or endorsement thereof. Use of such information may require a license from a third party under the patents or other intellectual property of the third party, or a license from TI under the patents or other intellectual property of TI.

Reproduction of significant portions of TI information in TI data books or data sheets is permissible only if reproduction is without alteration and is accompanied by all associated warranties, conditions, limitations, and notices. TI is not responsible or liable for such altered documentation. Information of third parties may be subject to additional restrictions.

Resale of TI components or services with statements different from or beyond the parameters stated by TI for that component or service voids all express and any implied warranties for the associated TI component or service and is an unfair and deceptive business practice. TI is not responsible or liable for any such statements.

Buyer acknowledges and agrees that it is solely responsible for compliance with all legal, regulatory and safety-related requirements concerning its products, and any use of TI components in its applications, notwithstanding any applications-related information or support that may be provided by TI. Buyer represents and agrees that it has all the necessary expertise to create and implement safeguards which anticipate dangerous consequences of failures, monitor failures and their consequences, lessen the likelihood of failures that might cause harm and take appropriate remedial actions. Buyer will fully indemnify TI and its representatives against any damages arising out of the use of any TI components in safety-critical applications.

In some cases, TI components may be promoted specifically to facilitate safety-related applications. With such components, TI's goal is to help enable customers to design and create their own end-product solutions that meet applicable functional safety standards and requirements. Nonetheless, such components are subject to these terms.

No TI components are authorized for use in FDA Class III (or similar life-critical medical equipment) unless authorized officers of the parties have executed a special agreement specifically governing such use.

Only those TI components which TI has specifically designated as military grade or "enhanced plastic" are designed and intended for use in military/aerospace applications or environments. Buyer acknowledges and agrees that any military or aerospace use of TI components which have **not** been so designated is solely at the Buyer's risk, and that Buyer is solely responsible for compliance with all legal and regulatory requirements in connection with such use.

TI has specifically designated certain components as meeting ISO/TS16949 requirements, mainly for automotive use. In any case of use of non-designated products, TI will not be responsible for any failure to meet ISO/TS16949.

### Products

Audio	<a href="http://www.ti.com/audio">www.ti.com/audio</a>
Amplifiers	<a href="http://amplifier.ti.com">amplifier.ti.com</a>
Data Converters	<a href="http://dataconverter.ti.com">dataconverter.ti.com</a>
DLP® Products	<a href="http://www.dlp.com">www.dlp.com</a>
DSP	<a href="http://dsp.ti.com">dsp.ti.com</a>
Clocks and Timers	<a href="http://www.ti.com/clocks">www.ti.com/clocks</a>
Interface	<a href="http://interface.ti.com">interface.ti.com</a>
Logic	<a href="http://logic.ti.com">logic.ti.com</a>
Power Mgmt	<a href="http://power.ti.com">power.ti.com</a>
Microcontrollers	<a href="http://microcontroller.ti.com">microcontroller.ti.com</a>
RFID	<a href="http://www.ti-rfid.com">www.ti-rfid.com</a>
OMAP Applications Processors	<a href="http://www.ti.com/omap">www.ti.com/omap</a>
Wireless Connectivity	<a href="http://www.ti.com/wirelessconnectivity">www.ti.com/wirelessconnectivity</a>

### Applications

Automotive and Transportation	<a href="http://www.ti.com/automotive">www.ti.com/automotive</a>
Communications and Telecom	<a href="http://www.ti.com/communications">www.ti.com/communications</a>
Computers and Peripherals	<a href="http://www.ti.com/computers">www.ti.com/computers</a>
Consumer Electronics	<a href="http://www.ti.com/consumer-apps">www.ti.com/consumer-apps</a>
Energy and Lighting	<a href="http://www.ti.com/energy">www.ti.com/energy</a>
Industrial	<a href="http://www.ti.com/industrial">www.ti.com/industrial</a>
Medical	<a href="http://www.ti.com/medical">www.ti.com/medical</a>
Security	<a href="http://www.ti.com/security">www.ti.com/security</a>
Space, Avionics and Defense	<a href="http://www.ti.com/space-avionics-defense">www.ti.com/space-avionics-defense</a>
Video and Imaging	<a href="http://www.ti.com/video">www.ti.com/video</a>

### TI E2E Community

[e2e.ti.com](http://e2e.ti.com)

## Looking for pricing, stock, or lifecycle information?

Click below to explore more details on WIN SOURCE:

 [View LM4570LQ/NOPB on WIN SOURCE](#)

 [Texas Instruments](#) Information

## Optimize Your Supply Chain with WIN SOURCE Solutions

-  Global Sourcing Solution
-  Obsolete Management
-  Cost Control Management
-  Shortage Management
-  Alternative Solution
-  Excess Inventory Management