



**THE DATASHEET OF
LM4546BVHX/NOPB**



LM4546B AC '97 Rev 2 Multi-Channel Audio Codec with Sample Rate Conversion and Texas Instruments 3D Sound

Check for Samples: [LM4546B](#)

FEATURES

- **AC '97 Rev 2.1 Compliant**
- **High Quality Sample Rate Conversion from 4 kHz to 48 kHz in 1 Hz Increments**
- **Multiple Codec Support**
- **Texas Instruments' 3D Sound Stereo Enhancement Circuitry**
- **Advanced Power Management Support**
- **Digital 3.3V and 5V Supply Options**
- **Extended Temperature: $-40^{\circ}\text{C} \leq T_A \leq 85^{\circ}\text{C}$**

APPLICATIONS

- **Desktop PC Audio Systems on PCI Cards, AMR Cards, or with Motherboard Chips Sets Featuring AC Link**
- **Portable PC Systems as on MDC Cards, or with a Chipset or Accelerator Featuring AC Link**
- **General and Multi-channel Audio Frequency Systems**
- **Automotive Telematics**

KEY SPECIFICATIONS

- **Analog Mixer Dynamic Range 97 dB (typ)**
- **DAC Dynamic Range 89 dB (typ)**
- **ADC Dynamic Range 90 dB (typ)**

DESCRIPTION

The LM4546B is an audio codec for PC systems which is fully PC99 compliant and performs the analog intensive functions of the AC '97 Rev 2.1 architecture. Using 18-bit Sigma-Delta ADCs and DACs, the LM4546B provides 90 dB of Dynamic Range.

The LM4546B was designed specifically to provide a high quality audio path and provide all analog functionality in a PC audio system. It features full duplex stereo ADCs and DACs and analog mixers with access to 2 stereo and 2 mono inputs. Each mixer input has separate gain, attenuation and mute control and the mixers drive 1 mono and 1 stereo output, each with attenuation and mute control. The LM4546B supports Texas Instruments' 3D Sound stereo enhancement and a comprehensive sample rate conversion capability. The sample rate for the ADCs and DACs can be programmed separately with a resolution of 1 Hz to convert any rate in the range 4 kHz – 48 kHz. Sample timing from the ADCs and sample request timing from the DACs are completely deterministic to ease task scheduling and application software development. These features together with an extended temperature range also make the LM4546B suitable for non-PC codec applications.

The LM4546B features the ability to connect several codecs together using the Extended AC Link configuration of one dedicated serial data signal to the Controller per codec. LM4546B systems support up to 8 simultaneous channels of streaming data on Input Frames (Codec to Controller) while Output Frames (Controller to Codec) carry 2 streams to multiple codecs. The LM4546B may also be used in systems with the Texas Instruments LM4550 to support up to 6 simultaneous channels of streaming data on Output Frames.

The AC '97 architecture separates the analog and digital functions of the PC audio system allowing both for system design flexibility and increased performance.



Please be aware that an important notice concerning availability, standard warranty, and use in critical applications of Texas Instruments semiconductor products and disclaimers thereto appears at the end of this data sheet.

All trademarks are the property of their respective owners.

Block Diagram

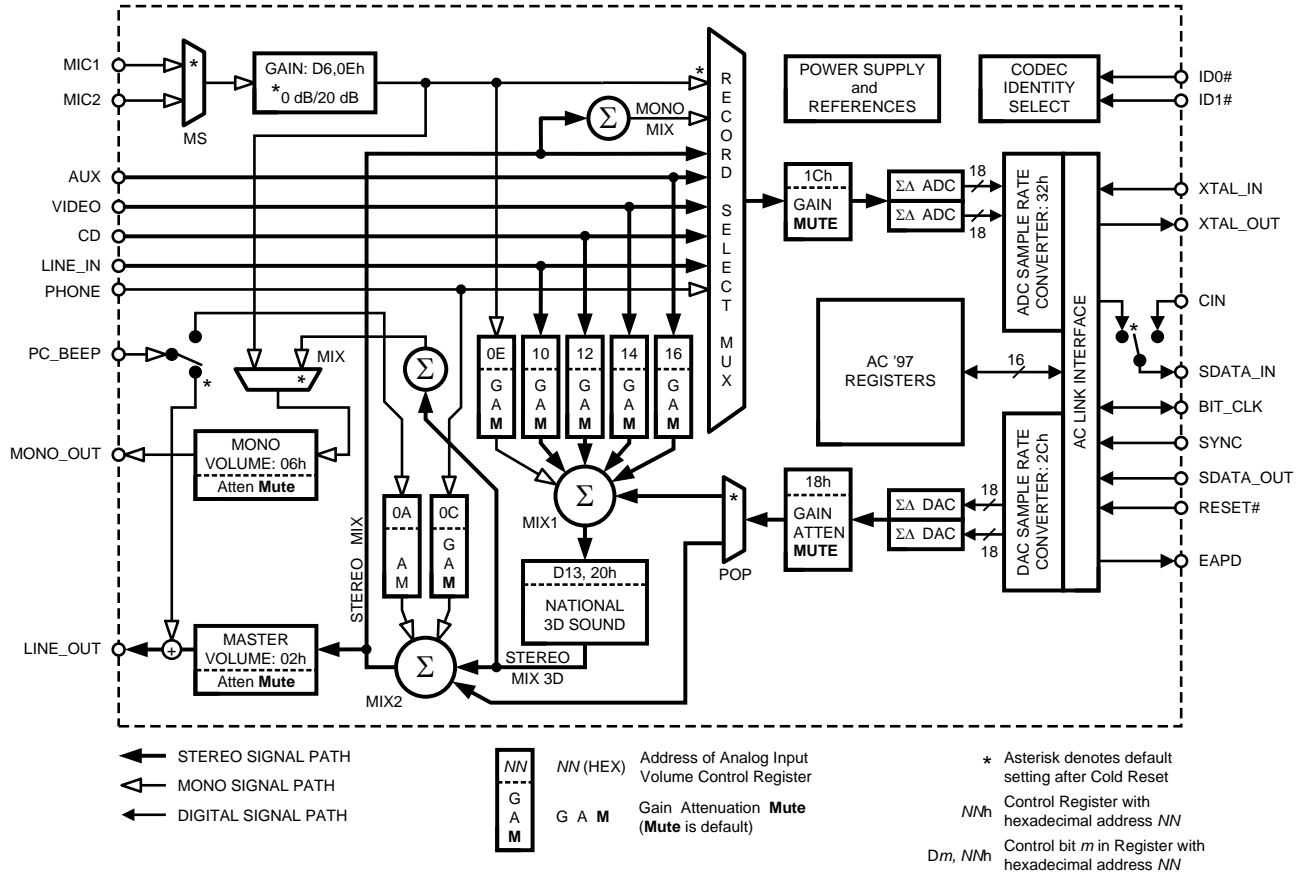

These devices have limited built-in ESD protection. The leads should be shorted together or the device placed in conductive foam during storage or handling to prevent electrostatic damage to the MOS gates.

Absolute Maximum Ratings⁽¹⁾⁽²⁾

Supply Voltage			6.0V
Storage Temperature			-65°C to +150°C
Input Voltage			-0.3V to V _{DD} + 0.3V
ESD Susceptibility ⁽³⁾			2000V
pin 3			750V
ESD Susceptibility ⁽⁴⁾			200V
pin 3			100V
Junction Temperature			150°C
Soldering Information	LQFP Package	Vapor Phase (60 sec.)	215°C
		Infrared (15 sec.)	220°C
θ _{JA} (typ) – PT0048A			74°C/W

- (1) *Absolute Maximum Ratings* indicate limits beyond which damage to the device may occur. *Operating Ratings* indicate conditions for which the device is functional, but do not ensure specific performance limits. *Electrical Characteristics* state DC and AC electrical specifications under particular test conditions which ensure specific performance limits. This assumes that the device is within the Operating Ratings. Specifications are not ensured for parameters where no limit is given, however, the typical value is a good indication of device performance.
- (2) If Military/Aerospace specified devices are required, please contact the Texas Instruments Sales Office/ Distributors for availability and specifications.
- (3) Human body model, 100 pF discharged through a 1.5 kΩ resistor.
- (4) Machine Model, 220 pF – 240 pF discharged through all pins.

Operating Ratings

Temperature Range	$T_{MIN} \leq T_A \leq T_{MAX}^{(1)}$	-40°C ≤ T _A ≤ 85°C
Analog Supply Range		4.2V ≤ AV _{DD} ≤ 5.5V
Digital Supply Range		3.0V ≤ DV _{DD} ≤ 5.5V

- (1) The maximum power dissipation must be derated at elevated temperatures and is dictated by T_{JMAX}, θ_{JA}, and the ambient temperature T_A. The maximum allowable power dissipation is P_{DMAX} = (T_{JMAX} - T_A)/θ_{JA} or the number given in Absolute Maximum Ratings, whichever is lower. For the LM4546B, T_{JMAX} = 150°C. The typical junction-to-ambient thermal resistance is 74°C/W for package number PT0048A.

Electrical Characteristics

⁽¹⁾⁽²⁾The following specifications apply for AV_{DD} = 5V, DV_{DD} = 3.3V, Sampling Frequency (F_s) = 48 kHz, single codec configuration, (primary mode) unless otherwise noted. Limits apply for T_A = 25°C. The reference for 0 dB is 1 V_{rms} unless otherwise specified.

Symbol	Parameter	Conditions	LM4546B		Units (Limits)
			Typical ⁽³⁾	Limit ⁽⁴⁾	
AV _{DD}	Analog Supply Range			4.2	V (min)
				5.5	V (max)
DV _{DD}	Digital Supply Range			3.0	V (min)
				5.5	V (max)
D _{IDD}	Digital Quiescent Power Supply Current	DV _{DD} = 5 V	34		mA
		DV _{DD} = 3.3 V	19		mA
A _{IDD}	Analog Quiescent Power Supply Current		53		mA
I _{DSD}	Digital Shutdown Current	PR543210 = 111111	19		μA
I _{ASD}	Analog Shutdown Current	PR543210 = 111111	70		μA

- (1) *Absolute Maximum Ratings* indicate limits beyond which damage to the device may occur. *Operating Ratings* indicate conditions for which the device is functional, but do not ensure specific performance limits. *Electrical Characteristics* state DC and AC electrical specifications under particular test conditions which ensure specific performance limits. This assumes that the device is within the Operating Ratings. Specifications are not ensured for parameters where no limit is given, however, the typical value is a good indication of device performance.
- (2) All voltages are measured with respect to the ground pin, unless otherwise specified.
- (3) Typicals are measured at 25°C and represent the parametric norm.
- (4) Limits are ensured to TI's AOQL (Average Outgoing Quality Level).

Electrical Characteristics (continued)

(1) (2) The following specifications apply for $V_{DD} = 5V$, $DV_{DD} = 3.3V$, Sampling Frequency (F_s) = 48 kHz, single codec configuration, (primary mode) unless otherwise noted. Limits apply for $T_A = 25^\circ C$. The reference for 0 dB is 1 Vrms unless otherwise specified.

Symbol	Parameter	Conditions	LM4546B		Units (Limits)
			Typical ⁽³⁾	Limit ⁽⁴⁾	
V_{REF}	Reference Voltage	No pullup resistor	2.16		V
PSRR	Power Supply Rejection Ratio		40		dB
Analog Loophrough Mode⁽⁵⁾					
	Dynamic Range ⁽⁶⁾	CD Input to Line Output, -60 dB Input THD+N	97	90	dB (min)
THD	Total Harmonic Distortion	$V_O = -3$ dB, $f = 1$ kHz, $R_L = 10$ k Ω	0.013	0.02	% (max)
Analog Input Section					
V_{IN}	Line Input Voltage	LINE_IN, AUX, CD, VIDEO, PC_BEEP, PHONE	1		Vrms
V_{IN}	Mic Input with 20 dB Gain		0.1		Vrms
V_{IN}	Mic Input with 0 dB Gain		1		Vrms
Xtalk	Crosstalk	CD Left to Right	-95		dB
Z_{IN}	Input Impedance ⁽⁶⁾	All Analog Inputs	40	10	k Ω (min)
C_{IN}	Input Capacitance ⁽⁶⁾		3.7	7	pF
	Interchannel Gain Mismatch	CD Left to Right	0.1		dB
Record Gain Amplifier - ADC					
A_S	Step Size	0 dB to 22.5 dB	1.5		dB
A_M	Mute Attenuation ⁽⁷⁾		86		dB
Mixer Section					
A_S	Step Size	+12 dB to -34.5 dB	1.5		dB
A_M	Mute Attenuation		86		dB
Analog to Digital Converters					
	Resolution		18		Bits
	Dynamic Range ⁽⁷⁾	-60 dB Input THD+N, A-Weighted	90	86	dB (min)
	Frequency Response	-1 dB Bandwidth	20		kHz
Digital to Analog Converters					
	Resolution		18		Bits
	Dynamic Range ⁽⁷⁾	-60 dB Input THD+N, A-Weighted	89	82	dB (min)
THD	Total Harmonic Distortion	$V_{IN} = -3$ dB, $f = 1$ kHz, $R_L = 10$ k Ω	0.01		%
	Frequency Response		20 - 21 k		Hz
	Group Delay ⁽⁷⁾	Sample Freq. = 48 kHz	0.36	1	ms (max)
	Out of Band Energy ⁽⁸⁾		-40		dB
	Stop Band Rejection		70		dB
D_T	Discrete Tones		-96		dB

(5) Loophrough mode describes a path from an analog input through the analog mixers to an analog output.

(6) These specifications are ensured by design and characterization; they are not production tested.

(7) These specifications are ensured by design and characterization; they are not production tested.

(8) Out of band energy is measured from 28.8 kHz to 100 kHz relative to a 1 Vrms DAC output.

Electrical Characteristics (continued)

⁽¹⁾ ⁽²⁾ The following specifications apply for $V_{DD} = 5V$, $DV_{DD} = 3.3V$, Sampling Frequency (F_s) = 48 kHz, single codec configuration, (primary mode) unless otherwise noted. Limits apply for $T_A = 25^\circ C$. The reference for 0 dB is 1 Vrms unless otherwise specified.

Symbol	Parameter	Conditions	LM4546B		Units (Limits)
			Typical ⁽³⁾	Limit ⁽⁴⁾	
Analog Output Section					
A_S	Step Size	0 dB to -46.5 dB	1.5		dB
A_M	Mute Attenuation		86		dB
Z_{OUT}	Output Impedance ⁽⁷⁾	All Analog Outputs	220		Ω
Digital I/O⁽⁷⁾					
V_{IH}	High level input voltage			$0.65 \times DV_{DD}$	V (min)
V_{IL}	Low level input voltage			$0.35 \times DV_{DD}$	V (max)
V_{OH}	High level output voltage	$I_O = -2.5$ mA.		$0.90 \times DV_{DD}$	V (min)
V_{OL}	Low level output voltage	$I_O = 2.5$ mA.		$0.10 \times DV_{DD}$	V (max)
I_L	Input Leakage Current	AC Link inputs		± 10	μA
I_L	Tri state Leakage Current	High impedance AC Link outputs		± 10	μA
C_{in}	AC-Link I/O capacitance	SDout, BitClk, SDin, Sync, Reset# only	4	7.5	pF(Max)
I_{DR}	Output drive current	AC Link outputs	5		mA
Digital Timing Specifications⁽⁷⁾					
F_{BC}	BIT_CLK frequency		12.288		MHz
T_{BCP}	BIT_CLK period		81.4		ns
T_{CH}	BIT_CLK high	Variation of BIT_CLK duty cycle from 50%		± 20	% (max)
F_{SYNC}	SYNC frequency		48		kHz
T_{SP}	SYNC period		20.8		μs
T_{SH}	SYNC high pulse width		1.3		μs
T_{SL}	SYNC low pulse width		19.5		μs
T_{DSETUP}	Setup Time for codec data input	SDATA_OUT to falling edge of BIT_CLK	3.5	10	ns (min)
T_{DHOLD}	Hold Time for codec data input	Hold time of SDATA_OUT from falling edge of BIT_CLK	5.3	10	ns (min)
T_{SSETUP}	Setup Time for codec SYNC input	SYNC to falling edge of BIT_CLK	3.8	10	ns (min)
T_{SHOLD}	Hold Time for codec SYNC input	Hold time of SYNC from falling edge of BIT_CLK		10	ns (min)
T_{CO}	Output Valid Delay	Output Delay of SDATA_IN from rising edge of BIT_CLK	5.2	15	ns (max)
T_{RISE}	Rise Time	BIT_CLK, SYNC, SDATA_IN or SDATA_OUT		6	ns (max)
T_{FALL}	Fall Time	BIT_CLK, SYNC, SDATA_IN or SDATA_OUT		6	ns (max)
T_{RST_LOW}	RESET# active low pulse width	For Cold Reset		1.0	μs (min)

Electrical Characteristics (continued)

(1) (2) The following specifications apply for $AV_{DD} = 5V$, $DV_{DD} = 3.3V$, Sampling Frequency (F_s) = 48 kHz, single codec configuration, (primary mode) unless otherwise noted. Limits apply for $T_A = 25^\circ C$. The reference for 0 dB is 1 Vrms unless otherwise specified.

Symbol	Parameter	Conditions	LM4546B		Units (Limits)
			Typical ⁽³⁾	Limit ⁽⁴⁾	
$T_{RST2CLK}$	RESET# inactive to BIT_CLK start up	For Cold Reset	271	162.8	ns (min)
T_{SH}	SYNC active high pulse width	For Warm Reset		1.0	μs (min)
$T_{SYNC2CLK}$	SYNC inactive to BIT_CLK start up	For Warm Reset		162.8	ns (min)
T_{S2_PDOWN}	AC Link Power Down Delay	Delay from end of Slot 2 to BIT_CLK, SDATA_IN low		1	μs (max)
$T_{SUPPLY2RST}$	Power On Reset	Time from minimum valid supply levels to end of Reset		1	μs (min)
T_{SU2RST}	Setup to trailing edge of RESET#	For ATE Test Mode		15	ns (min)
T_{RST2HZ}	Rising edge of RESET# to Hi-Z	For ATE Test Mode		25	ns (max)

Timing Diagrams

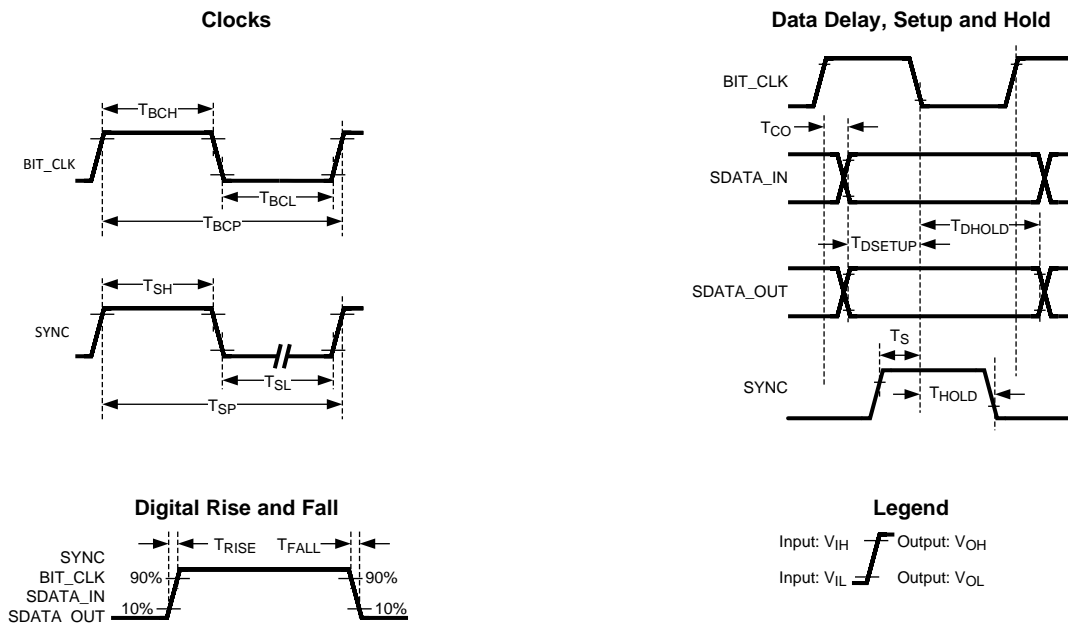

Figure 1. Power On Reset

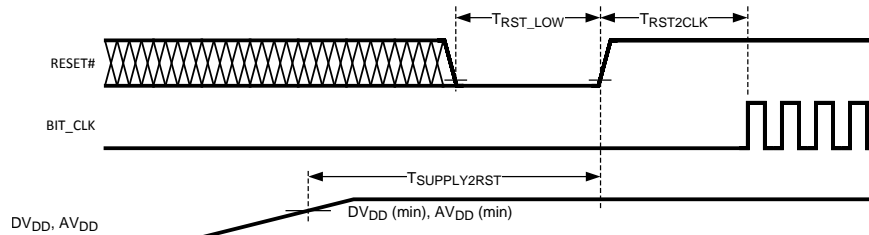

Figure 2. Cold Reset

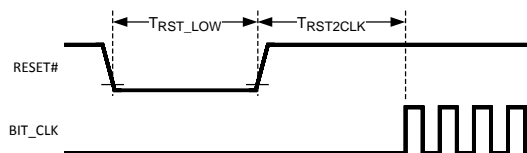
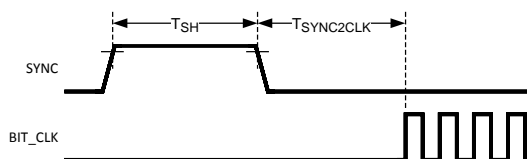

Figure 3. Warm Reset



Typical Application

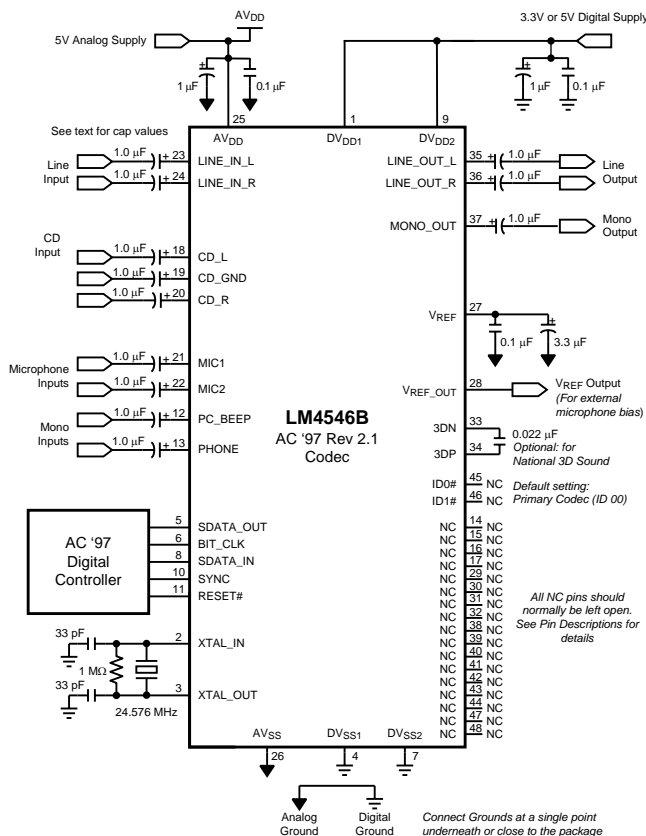

Figure 4. LM4546B Typical Application Circuit, Single Codec, 1 Vrms inputs

APPLICATION HINTS

- The LM4546B must be initialized by using RESET# to perform a Power-On-Reset as shown in [Figure 1](#)
- Don't leave unused analog inputs floating. Tie all unused inputs together and connect to Analog Ground through a capacitor (e.g. 0.1 μ F)
- Do not leave CD_GND floating when using the CD stereo input. CD_GND is the AC signal reference for the CD channels and should be connected to the CD source ground (Analog Ground may also be acceptable) through a 1 μ F capacitor
- If using a non-standard AC Link controller take care to keep the SYNC and SDATA_IN signals low during Cold Reset to avoid accidentally activating the ATE or Vendor test modes
- The PC_BEEP input should be explicitly muted if not used since it defaults to 0 dB gain on reset, unlike the mute default of the other analog inputs

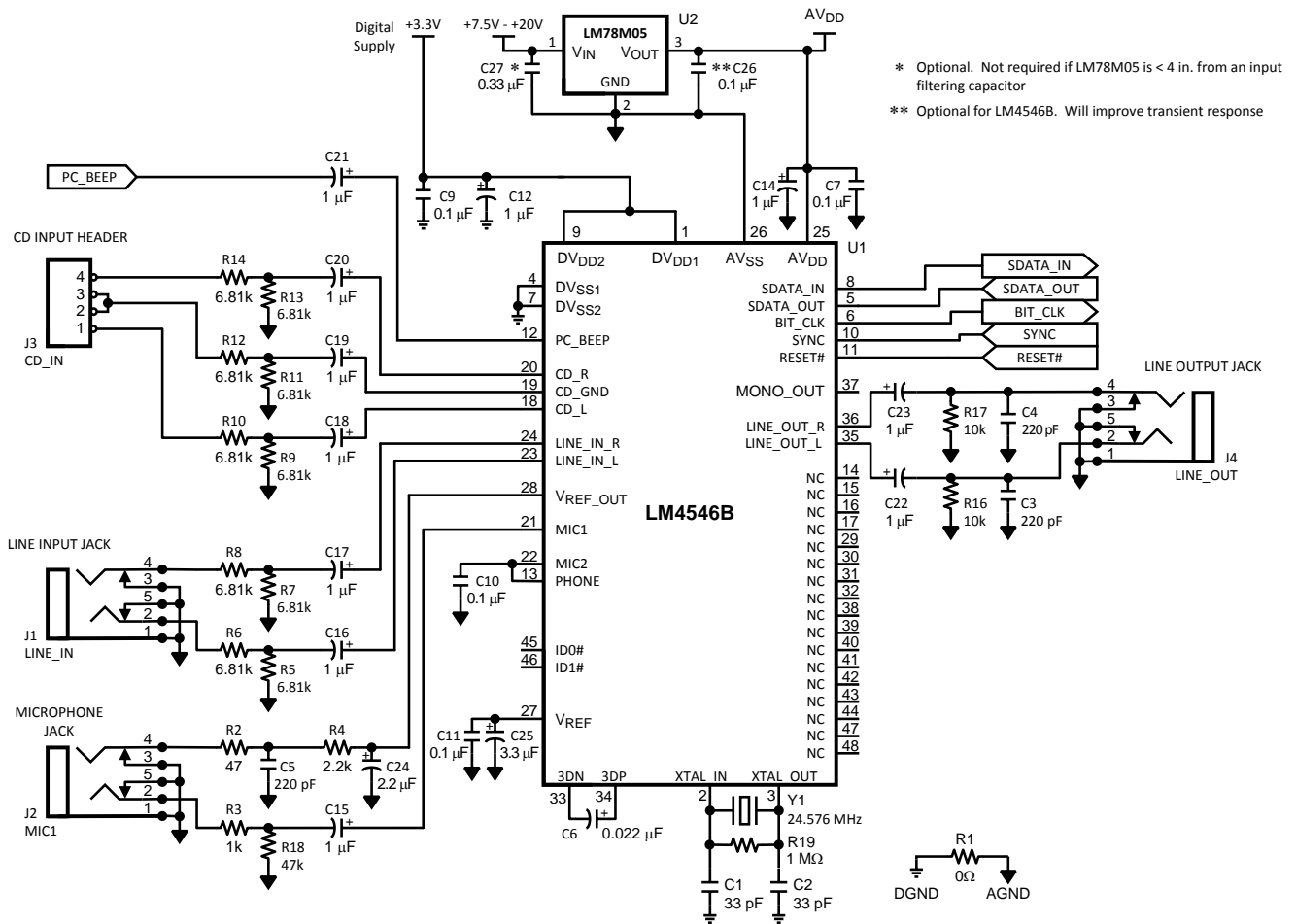

Figure 5. LM4546B Reference Design, Typical Application, Single Codec, 1 Vrms and 2 Vrms inputs, EMC output filters

Connection Diagram

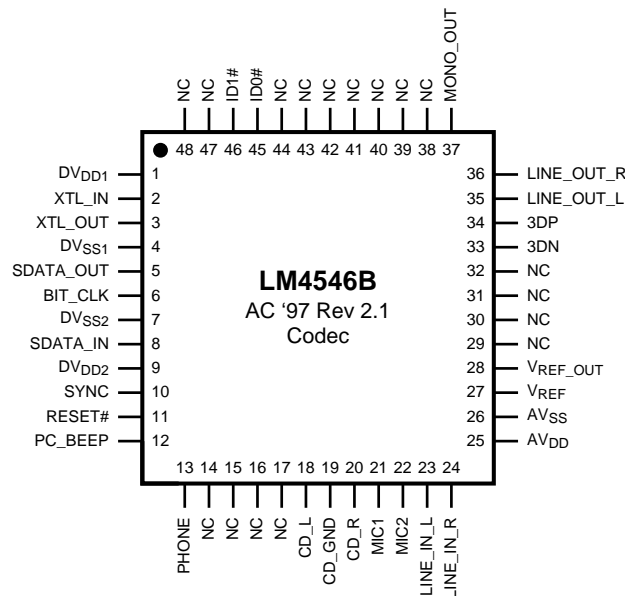

Figure 6. See Package Number PT0048A (Top View)

PIN DESCRIPTIONS

Table 1. ANALOG I/O

Name	Pin	I / O	Functional Description
PC_BEEP	12	I	Mono Input This line level (1 Vrms nominal) mono input is mixed equally into both channels of the Stereo Mix signal at MIX2 under the control of the PC_Beep Volume control register, 0Ah. The PC_BEEP level can be muted or adjusted from 0 dB to -45 dB in 3 dB steps. The Stereo Mix signal feeds both the Line Out and Line Level Out analog outputs and is also selectable at the Record Select Mux.
PHONE	13	I	Mono Input This line level (1 Vrms nominal) mono input is mixed equally into both channels of the Stereo Mix signal at MIX2 under the control of the Phone Volume register, 0Ch. The PHONE level can be muted or adjusted from +12 dB to -34.5 dB in 1.5 dB steps. The Stereo Mix signal feeds both the Line Out and Line Level Out analog stereo outputs and is also selectable at the Record Select Mux.
CD_L	18	I	Left Stereo Channel Input This line level input (1 Vrms nominal) is selectable at the left channel of the stereo Input Mux for conversion by the left channel ADC. It can also be mixed into the left channel of the Stereo Mix 3D signal at MIX1 under the control of the CD Volume register, 12h. The CD_L level can be muted (along with CD_R) or adjusted from +12 dB to -34.5 dB in 1.5 dB steps. Stereo Mix 3D is mixed into the Stereo Mix signal at MIX2 for access to the stereo outputs Line Out and Line Level Out.
CD_GND	19	I	AC Ground Reference This input is the reference for the signals on both CD_L and CD_R. CD_GND is NOT a DC ground and should be AC-coupled to the stereo source ground common to both CD_L and CD_R. The three inputs CD_GND, CD_L and CD_R act together as a quasi-differential stereo input with CD_GND providing AC common-mode feedback to reject ground noise. This can improve the input SNR for a stereo source with a good common ground but precision resistors may be needed in any external attenuators to achieve the necessary balance between the two channels.
CD_R	20	I	Right Stereo Channel Input This line level input (1 Vrms nominal) is selectable at the right channel of the stereo Input Mux for conversion by the right channel ADC. It can also be mixed into the right channel of the Stereo Mix 3D signal at MIX1 under the control of the CD Volume register, 12h. The CD_R level can be muted (along with CD_L) or adjusted from +12 dB to -34.5 dB in 1.5 dB steps. Stereo Mix 3D is combined into the Stereo Mix signal at MIX2 for access to the stereo outputs Line Out and Line Level Out.

Table 1. ANALOG I/O (continued)

Name	Pin	I / O	Functional Description
MIC1	21	I	Mono microphone input Either MIC1 or MIC2 can be muxed to a programmable boost amplifier with selection by the MS bit (bit D8) in the General Purpose register, 20h. The boost amplifier gain (0 dB or 20 dB) is set by the 20dB bit (D6) in the Mic Volume register, 0Eh. Nominal input levels at the two gain settings are 1 Vrms and 0.1 Vrms respectively. The amplifier output is selectable (Record Select register, 1Ah) by either the right or left channels of the Record Select Mux for conversion on either or both channels of the stereo ADC. The amplifier output can also be accessed at the stereo mixer MIX1 (muting and mixing adjustments via Mic Volume register, 0Eh) where it is mixed equally into both left and right channels of Stereo Mix 3D for access to the stereo outputs Line Out and Line Level Out. Access to the Mono analog output is selected by a mux controlled by the MIX bit (D9) in General Purpose register, 20h.
MIC2	22	I	Mono microphone input Either MIC1 or MIC2 can be muxed to a programmable boost amplifier with selection by the MS bit (bit D8) in the General Purpose register, 20h. The boost amplifier gain (0 dB or 20 dB) is set by the 20dB bit (D6) in the Mic Volume register, 0Eh. Nominal input levels at the two gain settings are 1 Vrms and 0.1 Vrms respectively. The amplifier output is selectable (Record Select register, 1Ah) by either the right or left channels of the Record Select Mux for conversion on either or both channels of the stereo ADCs. The amplifier output can also be accessed at the stereo mixer MIX1 (muting and mixing adjustments via Mic Volume register, 0Eh) where it is mixed equally into both left and right channels of Stereo Mix 3D for access to the stereo outputs Line Out and Line Level Out. Access to the Mono analog output is selected by a mux controlled by the MIX bit (D9) in General Purpose register, 20h.
LINE_IN_L	23	I	Left Stereo Channel Input This line level input (1 Vrms nominal) is selectable at the left channel of the stereo Record Select Mux for conversion by the left channel ADC. It can also be mixed into the left channel of the Stereo Mix 3D signal at MIX1 under the control of the Line In Volume register, 10h. The LINE_IN_L level can be muted (along with LINE_IN_R) or adjusted from +12 dB to -34.5 dB in 1.5 dB steps. Stereo Mix 3D is combined into the Stereo Mix signal at MIX2 for access to the stereo outputs Line Out and Line Level Out.
LINE_IN_R	24	I	Right Stereo Channel Input This line level input (1 Vrms nominal) is selectable at the right channel of the stereo Input Mux for conversion by the right channel ADC. It can also be mixed into the right channel of the Stereo Mix 3D signal at MIX1 under the control of the Line In Volume register, 10h. The LINE_IN_R level can be muted (along with LINE_IN_L) or adjusted from +12 dB to -34.5 dB in 1.5 dB steps. Stereo Mix 3D is combined into the Stereo Mix signal at MIX2 for access to the stereo outputs Line Out and Line Level Out.
LINE_OUT_L	35	O	Left Stereo Channel Output This line level output (1 Vrms nominal) is fed from the left channel of the Stereo Mix signal from MIX2 via the Master Volume register, 02h. The LINE_OUT_L amplitude can be muted (along with LINE_OUT_R) or adjusted from 0 dB to -46.5 dB in 1.5 dB steps.
LINE_OUT_R	36	O	Right Stereo Channel Output This line level output (1 Vrms nominal) is fed from the right channel of the Stereo Mix signal from MIX2 via the Master Volume register, 02h. The LINE_OUT_R amplitude can be muted (along with LINE_OUT_L) or adjusted from 0 dB to -46.5 dB in 1.5 dB steps.
MONO_OUT	37	O	Mono Output This mono line level output (1 Vrms nominal) is fed from either a microphone input (MIC1 or MIC2, after boost amplifier) or from the mono sum of the left and right Stereo Mix 3D channels from MIX1. The optional Texas Instruments 3D Sound enhancement can be disabled (default) by the 3D bit (bit D13) in the General Purpose register, 20h. Choice of input is by the MIX bit (D9) in the same register. MIX=0 selects a microphone input. Output level can be muted or adjusted from 0 dB to -46.5 dB in 1.5 dB steps via the Mono Volume register, 06h.

Table 2. DIGITAL I/O AND CLOCKING

Name	Pin	I / O	Functional Description
XTL_IN	2	I	24.576 MHz crystal or oscillator input To complete the oscillator circuit use a fundamental mode crystal operating in parallel resonance and connect a 1MΩ resistor across pins 2 and 3. Choose the load capacitors (Figure 5, C1, C2) to suit the load capacitance required by the crystal (e.g. C1 = C2 = 33 pF for a 20 pF crystal Assumes that each 'Input + trace' capacitance = 7 pF). This pin may also be used as the input for an external oscillator (24.576 MHz nominal) at standard logic levels (V _{IH} , V _{IL}). This pin is only used when the codec is in Primary mode. It may be left open (NC) for any Secondary mode.

Table 2. DIGITAL I/O AND CLOCKING (continued)

Name	Pin	I / O	Functional Description
XTL_OUT	3	O	24.576 MHz crystal output Used with XTAL_IN to configure a crystal oscillator. When the codec is used with an external oscillator this pin should be left open (NC). When the codec is configured in a Secondary mode this pin is not used and may be left open (NC).
SDATA_OUT	5	I	Input to codec This is the input for AC Link Output Frames from an AC '97 Digital Audio Controller to the LM4546B codec. These frames can contain both control data and DAC PCM audio data. This input is sampled by the LM4546B on the falling edge of BIT_CLK.
BIT_CLK	6	I/O	AC Link clock An OUTPUT when in Primary Codec mode. This pin provides a 12.288 MHz clock for the AC Link. The clock is derived (internally divided by two) from the 24.576 MHz signal at the crystal input (XTL_IN). This pin is an INPUT when the codec is configured in any of the Secondary Codec modes and would normally use the AC Link clock generated by a Primary Codec.
SDATA_IN	8	O	Output from codec This is the output for AC Link Input Frames from the LM4546B codec to an AC '97 Digital Audio Controller. These frames can contain both codec status data and PCM audio data from the ADCs. The LM4546B clocks data from this output on the rising edge of BIT_CLK.
SYNC	10	I	AC Link frame marker and Warm Reset This input defines the boundaries of AC Link frames. Each frame lasts 256 periods of BIT_CLK. In normal operation SYNC is a 48 kHz positive pulse with a duty cycle of 6.25% (16/256). SYNC is sampled on the falling edge of BIT_CLK and the codec takes the first positive sample of SYNC as defining the start of a new AC Link frame. If a subsequent SYNC pulse occurs within 255 BIT_CLK periods of the frame start it will be ignored. SYNC is also used as an active high input to perform an (asynchronous) Warm Reset. Warm Reset is used to clear a power down state on the codec AC Link interface.
RESET#	11	I	Cold Reset This active low signal causes a hardware reset which returns the control registers and all internal circuits to their default conditions. RESET# MUST be used to initialize the LM4546B after Power On when the supplies have stabilized. Cold Reset also clears the codec from both ATE and Vendor test modes. In addition, while active, it switches the PC_BEEP mono input directly to both channels of the LINE_OUT stereo output.
ID0	45	I	Codec Identity ID1 and ID0 determine the Codec Identity for multiple codec use. The Codec Identity configures the codec in either Primary or one of three Secondary Codec modes. These Identity pins are of inverted polarity relative to the Codec Identity bits ID1, ID0 (bits D15, D14) in the read-only Extended Audio ID register, 28h. If the ID0# pin (pin 45) is connected to ground then the ID0 bit (D14, reg 28h) will be set to "1". Similarly, connection to DV _{DD} will set the ID0 bit to "0". If left open (NC), ID0# is pulled high by an internal pull-up resistor.
ID1	46	I	Codec Identity ID1# and ID0# determine the codec address for multiple codec use. The Codec Identity configures the codec in either Primary or one of three Secondary Codec modes. These Identity pins are of inverted polarity relative to the Codec Identity bits ID1, ID0 (bits D15, D14) in the read-only Extended Audio ID register, 28h. If the ID1# pin (pin 46) is connected to ground then the ID1 bit (D15, reg 28h) will be set to "1". Similarly, connection to DV _{DD} will set the ID1 bit to "0". If left open (NC), ID1# is pulled high by an internal pull-up resistor.

Table 3. POWER SUPPLIES AND REFERENCES

Name	Pin	I / O	Functional Description
AV _{DD}	25	I	Analog supply
AV _{SS}	26	I	Analog ground
DV _{DD1}	1	I	Digital supply
DV _{DD2}	9	I	Digital supply
DV _{SS1}	4	I	Digital ground
DV _{SS2}	7	I	Digital ground
V _{REF}	27	O	Nominal 2.2 V internal reference Not intended to sink or source current. Use short traces to bypass (3.3 μ F, 0.1 μ F) this pin to maximize codec performance. See text.
V _{REF_OUT}	28	O	Nominal 2.2 V reference output Can source up to 5 mA of current and can be used to bias a microphone.

Table 4. 3D SOUND AND NO-CONNECTS (NC)

Name	Pin	I / O	Functional Description
3DP, 3DN	33,34	O	These pins are used to complete the Texas Instruments' 3D Sound stereo enhancement circuit. Connect a 0.022 μ F capacitor between pins 3DP and 3DN. Texas Instruments' 3D Sound can be turned on and off via the 3D bit (D13) in the General Purpose register, 20h. Texas Instruments' 3D Sound uses a fixed-depth type stereo enhancement circuit hence the 3D Control register, 22h is read-only and is not programmable. If Texas Instruments' 3D Sound is not needed, these pins should be left open (NC).
NC	14–17 29–32 38–44 47, 48	NC	These pins are not used and should be left open (NC). For second source applications these pins may be connected to a noise-free supply or ground (e.g. AV _{DD} or AV _{SS}), either directly or through a capacitor.

Typical Performance Characteristics

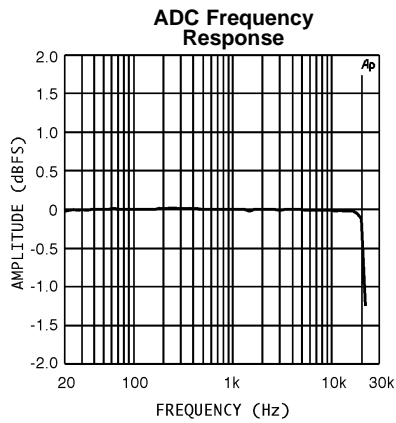

Figure 7.

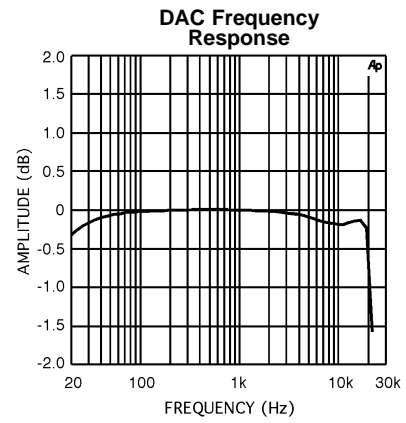

Figure 8.

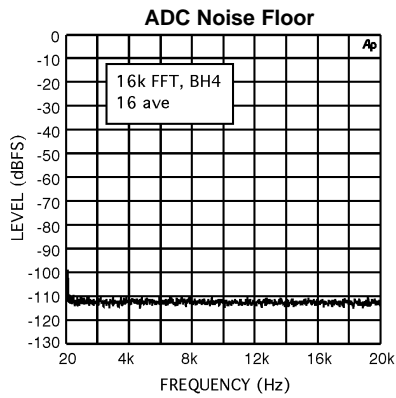

Figure 9.

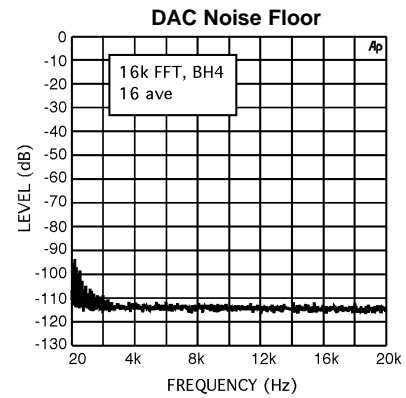

Figure 10.

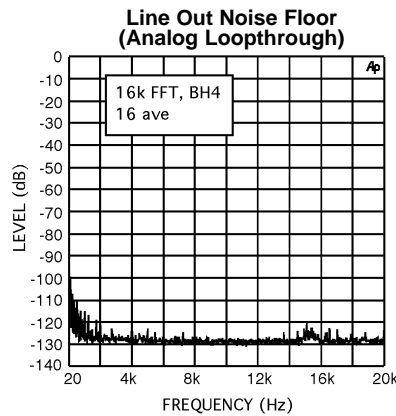

Figure 11.

Table 5. LM4546B Register Map

	REG	Name	D15	D14	D13	D12	D11	D10	D9	D8	D7	D6	D5	D4	D3	D2	D1	D0	Default
	00h	Reset	X	0	0	0	1	1	0	1	0	1	0	0	0	0	0	0	0D40h
Output Volume	02h	Master Volume	Mute	X	ML5	ML4	ML3	ML2	ML1	ML0	X	X	MR5	MR4	MR3	MR2	MR1	MR0	8000h
	06h	Mono Volume	Mute	X	X	X	X	X	X	X	X	X	MM5	MM4	MM3	MM2	MM1	MM0	8000h
Input Volume	0Ah	PC_Beep Volume	Mute	X	X	X	X	X	X	X	X	X	X	PV3	PV2	PV1	PV0	X	0000h
	0Ch	Phone Volume	Mute	X	X	X	X	X	X	X	X	X	X	GN4	GN3	GN2	GN1	GN0	8008h
	0Eh	Mic Volume	Mute	X	X	X	X	X	X	X	X	20dB	X	GN4	GN3	GN2	GN1	GN0	8008h
	10h	Line In Volume	Mute	X	X	GL4	GL3	GL2	GL1	GL0	X	X	X	GR4	GR3	GR2	GR1	GR0	8808h
	12h	CD Volume	Mute	X	X	GL4	GL3	GL2	GL1	GL0	X	X	X	GR4	GR3	GR2	GR1	GR0	8808h
	18h	PCM Out Volume	Mute	X	X	GL4	GL3	GL2	GL1	GL0	X	X	X	GR4	GR3	GR2	GR1	GR0	8808h
ADC Sources	1Ah	Record Select	X	X	X	X	X	SL2	SL1	SL0	X	X	X	X	X	SR2	SR1	SR0	0000h
	1Ch	Record Gain	Mute	X	X	X	GL3	GL2	GL1	GL0	X	X	X	X	GR3	GR2	GR1	GR0	8000h
	20h	General Purpose	POP	X	3D	X	X	X	MIX	MS	LPBK	X	X	X	X	X	X	X	0000h
	22h	3D Control (Read Only)	X	0	0	0	0	0	0	1	0	0	0	0	0	0	0	1	0101h
X	24h	Reserved	X	X	X	X	X	X	X	X	X	X	X	X	X	X	X	X	0000h
	26h	Powerdown Control/Status	PR7	PR6	PR5	PR4	PR3	PR2	PR1	PR0	X	X	X	X	REF	ANL	DAC	ADC	000Xh
	28h	Extended Audio ID	ID1	ID0	X	X	X	X	0	0	0	0	X	X	0	X	0	VRA	X001h
	2Ah	Extended Audio Control/Status	X	X	X	X	X	X	X	X	X	X	X	X	X	X	X	VRA	0000h
	2Ch	PCM DAC Rate	SR15	SR14	SR13	SR12	SR11	SR10	SR9	SR8	SR7	SR6	SR5	SR4	SR3	SR2	SR1	SR0	BB80h
	32h	PCM ADC Rate	SR15	SR14	SR13	SR12	SR11	SR10	SR9	SR8	SR7	SR6	SR5	SR4	SR3	SR2	SR1	SR0	BB80h
X	5Ah	Vendor Reserved 1	X	X	X	X	X	X	X	X	X	X	X	X	X	X	X	X	0000h
X	74h	Vendor Reserved 2	X	X	X	X	X	X	X	X	X	X	X	X	X	X	X	X	0000h
X	7Ah	Vendor Reserved 3	X	X	X	X	X	X	X	X	X	X	X	X	X	X	X	X	0000h
	7Ch	Vendor ID1	0	1	0	0	1	1	1	0	0	1	0	1	0	0	1	1	4E53h
	7Eh	Vendor ID2	0	1	0	0	0	0	1	1	0	1	0	0	0	1	1	0	4346h

Functional Description

GENERAL

The LM4546B codec can mix, process and convert among analog (stereo and mono) and digital (AC Link format) inputs and outputs. There are two stereo and four mono analog inputs and one stereo and one mono analog outputs. A single codec supports data streaming on two input and two output channels of the AC Link digital interface simultaneously.

ADC INPUTS AND OUTPUTS

Both stereo analog inputs and three of the mono analog inputs can be selected for conversion by the 18-bit stereo ADC. Digital output from the left and right channel ADCs is always located in AC Link Input Frame slots 3 and 4 respectively. Input level to either ADC channel can be muted or adjusted from the Record Gain register, 1Ch. Adjustments are in 1.5 dB steps over a gain range of 0 dB to +22.5 dB and both channels mute together (D15). Input selection for the ADC is through the Record Select Mux controlled from the Record Select register, 1Ah, together with microphone selection controlled by the MS bit (D8) in the General Purpose register, 20h. The stereo input, CD_IN, uses a quasi-differential 3-pin interface where both stereo channel inputs are referenced to the third pin, CD_GND. CD_GND should be AC coupled to the source ground and provides common-mode feedback to cancel ground noise. It is not a DC ground. The other stereo input, LINE_IN, is a 2-pin interface,

single-ended for each stereo channel with analog ground (AV_{SS}) as the signals' reference. Either of the two mono microphone inputs can be muxed to a programmable boost amplifier before selection for either channel of the ADC. The Microphone Mux is controlled by the Microphone Selection (MS) bit (D8) in the General Purpose register 20h and the 20 dB programmable boost is enabled by the 20dB bit (D6) in register 0Eh. The other selectable mono input, coupled directly to the Record Select Mux, is PHONE.

ANALOG MIXING: MIX1

Three analog inputs are available for mixing at the stereo mixer, MIX1 – both stereo and one mono, namely the microphone input selected by MS (D8, reg 20h). Digital input to the codec can be directed to either MIX1 or to MIX2 after conversion by the 18-bit stereo DAC and level adjustment by the PCM Out Volume control register (18h). Each input to MIX1 may be muted or level adjusted using the appropriate Mixer Input Volume Register: Mic Volume (0Eh), Line_In Volume (10h), CD Volume (12h) and PCM Out Volume (18h). The mono microphone input is mixed equally into left and right stereo channels but stereo mixing is orthogonal, *i.e.* left channels are only mixed with other left channels and right with right. The left and right amplitudes of any stereo input may be adjusted independently however mute for a stereo input acts on both left and right channels.

DAC MIXING AND 3D PROCESSING

Control of routing the DAC output to MIX1 or MIX2 is by the POP bit (D15) in the General Purpose register, 20h. If MIX1 is selected (default, POP=0) then the DAC output is available for processing by the Texas Instruments 3D Sound circuitry. If MIX2 is selected, the DAC output will bypass the 3D processing. This allows analog inputs to be enhanced by the analog 3D Sound circuitry prior to mixing with digital audio. The digital audio may then use alternative digital 3D enhancements. Texas Instruments 3D Sound circuitry is enabled by the 3D bit (D13) in the General Purpose register, 20h, and is a fixed depth implementation. The 3D Control register, 22h, is therefore not programmable (read-only). The 3D Sound circuitry defaults to disabled after reset.

ANALOG MIXING: MIX2

MIX2 combines the output of MIX1 (Stereo Mix 3D) with the two mono analog inputs, PHONE and PC_BEEP; each are each level-adjusted by the input control registers, Phone Volume (0Ch) and PC_Beep Volume (0Ah), respectively. If selected by the POP bit (D15, reg 20h), the DAC output is also summed into MIX2.

STEREO MIX

The output of MIX2 is the signal, Stereo Mix. Stereo Mix is used to drive the Line output (LINE_OUT) and can also be selected as the input to the ADC by the Record Select Mux. In addition, the two channels of Stereo Mix are summed to form a mono signal (Mono Mix) also selectable by the Record Select Mux as an input to either channel of the ADC.

STEREO OUTPUT

The output volume from LINE_OUT can be muted or adjusted by 0 dB to 45 dB in nominal 3 dB steps under the control of the Master Volume register, 02h. As with the input volume registers, adjustments to the levels of the two stereo channels can be made independently but both left and right channels share a mute bit (D15).

MONO OUTPUT

The mono output (MONO_OUT) is driven by one of two signals selected by the MIX bit (D9) in the General Purpose register, 20h. The signal selected by default (MIX = 0) is the mono summation of the two channels of Stereo Mix 3D, the stereo output of the mixer MIX1. Setting the control bit MIX = 1, selects a microphone input, MIC1 or MIC2. The choice of microphone is controlled by the Microphone Select (MS) bit (D8) also in the General Purpose register, 20h.

ANALOG LOOPTHROUGH AND DIGITAL LOOPBACK

Analog Loopthrough refers to an all-analog signal path from an analog input through the mixers to an analog output. Digital Loopback refers to a mixed-mode analog and digital signal path from an analog input through the ADC, looped-back (LPBK bit – D7, 20h) through the DAC and mixers to an analog output. This is an 18 bit digital loopback, bypassing the SRC logic, at a 48 kHz rate, even if another sample rate conversion is selected.

RESETS

COLD RESET is performed when RESET# (pin 11) is pulled low for $> 1 \mu\text{s}$. It is a complete reset. All registers and internal circuits are reset to their default state. It is the only reset which clears the ATE and Vendor Test Modes.

WARM RESET is performed when SYNC (pin 10) is held high for $> 1 \mu\text{s}$ and the codec AC Link digital interface is in powerdown (PR4 = 1, Powerdown Control / Status register, 26h). It is used to clear PR4 and power up the AC Link digital interface but otherwise does not change the contents of any registers nor reset any internal circuitry.

REGISTER RESET is performed when any value is written to the RESET register, 00h. It resets all registers to their default state and will modify circuit configurations accordingly but does not reset any other internal circuits.

AC Link Serial Interface Protocol

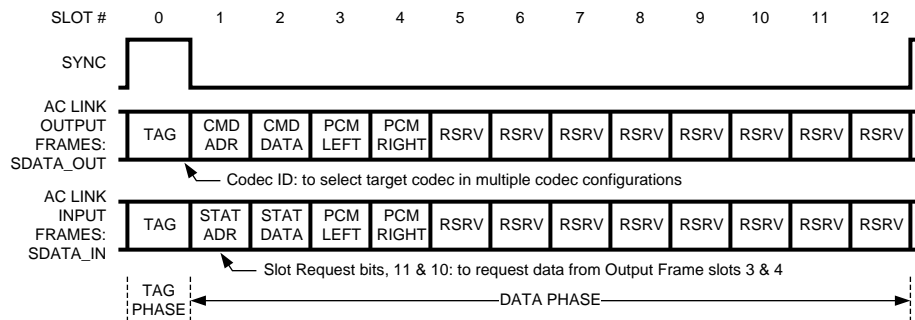

Figure 12. AC Link Bidirectional Audio Frame

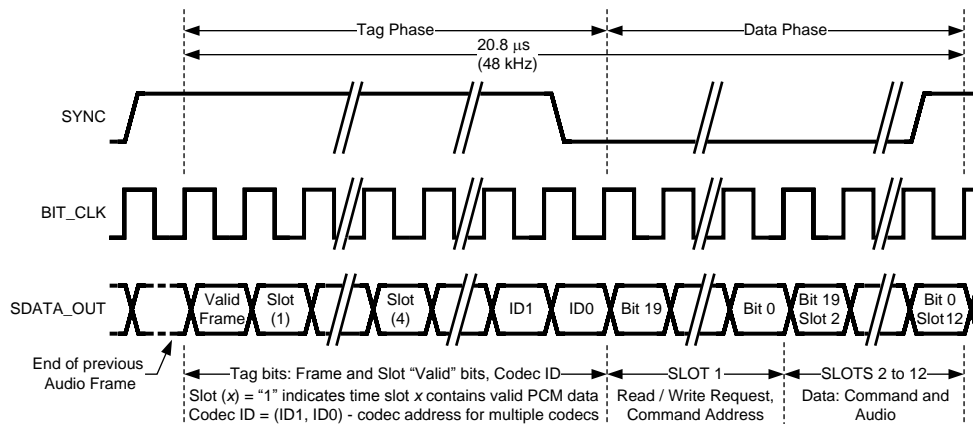

Figure 13. AC Link Output Frame

AC LINK OUTPUT FRAME: SDATA_OUT, CONTROLLER OUTPUT TO LM4546B INPUT

The AC Link Output Frame carries control and PCM data to the LM4546B control registers and stereo DAC. Output Frames are carried on the SDATA_OUT signal which is an output from the AC '97 Digital Controller and an input to the LM4546B codec. As shown in Figure 12, Output Frames are constructed from thirteen time slots: one Tag Slot followed by twelve Data Slots. Each Frame consists of 256 bits with each of the twelve Data Slots containing 20 bits. Input and Output Frames are aligned to the same SYNC transition. Note that since the LM4546B is a two channel codec, it only accepts data in 4 of the twelve Data Slots – 2 for control, one each for PCM data to the left and right channel DACs. Data Slot 3 & 4 are used to stream data to the stereo DAC for all modes selected by the Identity pins ID1#, ID0#.

A new Output Frame is signaled with a low-to-high transition of SYNC. SYNC should be clocked from the controller on a rising edge of BIT_CLK and, as shown in Figure 13 and Figure 14, the first tag bit in the Frame (“Valid Frame”) should be clocked from the controller by the next rising edge of BIT_CLK and sampled by the LM4546B on the following falling edge. The AC '97 Controller should always clock data to SDATA_OUT on a rising edge of BIT_CLK and the LM4546B always samples SDATA_OUT on the next falling edge. SYNC is sampled with the falling edge of BIT_CLK.

The LM4546B checks each Frame to ensure 256 bits are received. If a new Frame is detected (a low-to-high transition on SYNC) before 256 bits are received from the old Frame then the new Frame is ignored *i.e.* the data on SDATA_OUT is discarded until a valid new Frame is detected.

The LM4546B expects to receive data MSB first, in an MSB justified format.

SDATA_OUT: Slot 0 – Tag Phase

The first bit of Slot 0 is designated the “Valid Frame” bit. If this bit is 1, it indicates that the current Output Frame contains at least one slot of valid data and the LM4546B will check further tag bits for valid data in the expected Data Slots. With the codec in Primary mode, a controller will indicate valid data in a slot by setting the associated tag bit equal to 1. Since it is a two channel codec the LM4546B can only receive data from four slots in a given frame and so only checks the valid-data bits for 4 slots. In Primary mode these tag bits are for: slot 1 (Command Address), slot 2 (Command Data), slot 3 (PCM data for left DAC) and slot 4 (PCM data for right DAC).

The last two bits in the Tag contain the Codec ID used to select the target codec to receive the frame in multiple codec systems. When the frame is being sent to a codec in one of the Secondary modes the controller does not use bits 14 and 13 to indicate valid Command Address and Data in slots 1 and 2. Instead, this role is performed by the Codec ID bits – operation of the Extended AC Link assumes that the controller would not access a secondary codec unless it was providing valid Command Address and/or Data. When in one of the secondary modes the LM4546B only checks the tag bits for the Codec ID and for valid data in the two audio data slots 3 & 4.

When sending an Output Frame to a Secondary mode codec, a controller should set tag bits 14 and 13 to zero.

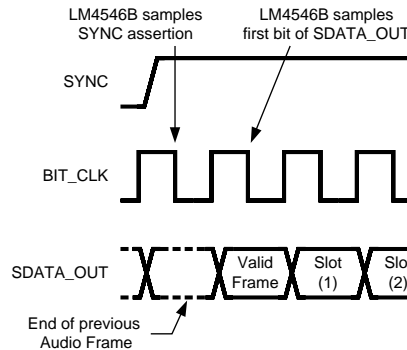

Figure 14. Start of AC Link Output Frame

Table 6. SLOT 0, OUTPUT FRAME

Bit	Description	Comment	
15	Valid Frame	1 =	Valid data in at least one slot.
14	Control register address	1 =	Valid Control Address in Slot 1 (Primary codec only)
13	Control register data	1 =	Valid Control Data in Slot 2 (Primary codec only)
12	Left DAC data in Slot 3	1 =	Valid PCM Data in Slot 3 (Primary & all Secondary modes)
11	Right DAC data in Slot 4	1 =	Valid PCM Data in Slot 4 (Primary & all Secondary modes)
10:2	Not Used	Controller should stuff these slots with “0”s	
1,0	Codec ID (ID1, ID0)	The codec ID is used in a multi-codec system to identify the target Secondary codec for the Control Register address and/or data sent in the Output Frame	

SDATA_OUT: Slot 1 – Read/Write, Control Address

Slot 1 is used by a controller to indicate both the address of a target register in the LM4546B and whether the access operation is a register read or register write. The MSB of slot 1 (bit 19) is set to 1 to indicate that the current access operation is 'read'. Bits 18 through 12 are used to specify the 7-bit register address of the read or write operation. The least significant twelve bits are reserved and should be stuffed with zeros by the AC '97 controller.

Table 7. SLOT 1, OUTPUT FRAME

Bits	Description	Comment
19	Read/Write	1 = Read 0 = Write
18:12	Register Address	Identifies the Status/Command register for read/write
11:0	Reserved	Controller should set to "0"

SDATA_OUT: Slot 2 – Control Data

Slot 2 is used to transmit 16-bit control data to the LM4546B when the access operation is 'write'. The least significant four bits should be stuffed with zeros by the AC '97 controller. If the access operation is a register read, the entire slot, bits 19 through 0 should be stuffed with zeros.

Table 8. SLOT 2, OUTPUT FRAME

Bits	Description	Comment
19:4	Control Register Write Data	Controller should stuff with zeros if operation is "read"
3:0	Reserved	Set to "0"

SDATA_OUT: Slots 3 & 4 – PCM Playback Left/Right Channels

Slots 3 and 4 are 20-bit fields used to transmit PCM data to the left and right channels of the stereo DAC for all codec Primary and Secondary modes. Any unused bits should be stuffed with zeros. The LM4546B DACs have 18-bit resolution and will therefore use the 18 MSBs of the 20-bit PCM data (MSB justified).

Table 9. SLOTS 3 & 4, OUTPUT FRAME

Bits	Description	Comment
19:0	PCM DAC Data (Left /Right Channels)	Slots used to stream data to DACs for all Primary or Secondary modes. Set unused bits to "0"

SDATA_OUT: Slots 5 to 12 – Reserved

These slots are not used by the LM4546B and should all be stuffed with zeros by the AC '97 Controller.

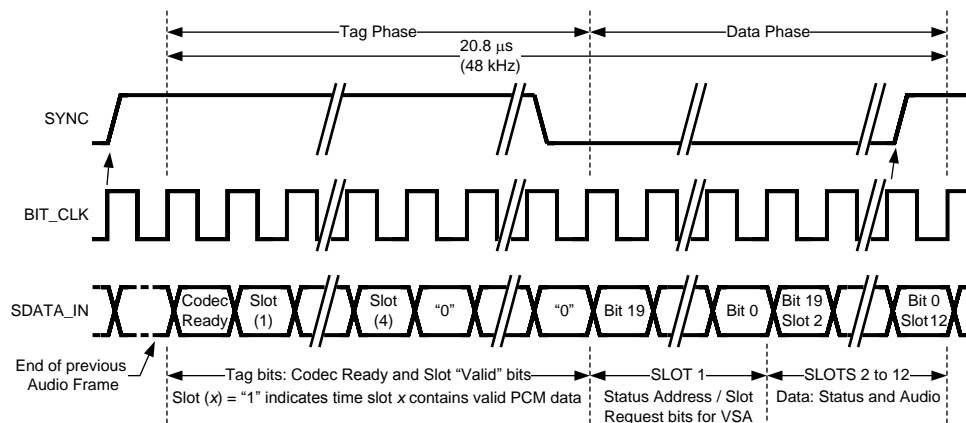

Figure 15. AC Link Input Frame

**AC LINK INPUT FRAME:
SDATA_IN, CONTROLLER INPUT FROM LM4546B OUTPUT**

The AC Link Input Frame contains status and PCM data from the LM4546B control registers and stereo ADC. Input Frames are carried on the SDATA_IN signal which is an input to the AC '97 Digital Audio Controller and an output from the LM4546B codec. As shown in Figure 12, Input Frames are constructed from thirteen time slots: one Tag Slot followed by twelve Data Slots. The Tag Slot, Slot 0, contains 16 bits of which 5 are used by the LM4546B. One is used to indicate that the AC Link interface is fully operational and the other 4 to indicate the validity of the data in the four of the twelve following Data Slots that are used by the LM4546B. Each Frame consists of 256 bits with each of the twelve data slots containing 20 bits.

A new Input Frame is signaled with a low-to-high transition of SYNC. SYNC should be clocked from the controller on a rising edge of BIT_CLK and, as shown in Figure 15 and Figure 16, the first tag bit in the Frame (“Codec Ready”) is clocked from the LM4546B by the next rising edge of BIT_CLK. The LM4546B always clocks data to SDATA_IN on a rising edge of BIT_CLK and the controller is expected to sample SDATA_IN on the next falling edge. The LM4546B samples SYNC on the falling edge of BIT_CLK.

Input and Output Frames are aligned to the same SYNC transition.

The LM4546B checks each Frame to ensure 256 bits are received. If a new Frame is detected (a low-to-high transition on SYNC) before 256 bits are received from an old Frame then the new Frame is ignored *i.e.* no valid data is sent on SDATA_IN until a valid new Frame is detected.

The LM4546B transmits data MSB first, in a MSB justified format. All reserved bits and slots are stuffed with "0"s by the LM4546B.

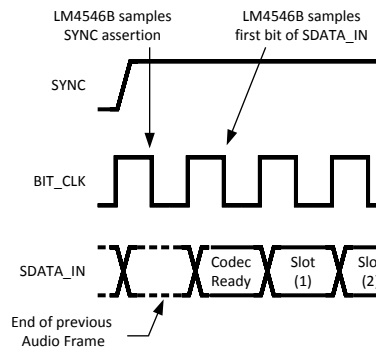

Figure 16. Start of AC Link Input Frame

SDATA_IN: Slot 0 – Codec/Slot Status Bits

The first bit (bit 15, “Codec Ready”) of slot 0 in the AC Link Input Frame indicates when the codec's AC Link digital interface and its status/control registers are fully operational. The digital controller is then able to read the LSBs from the Powerdown Control/Stat register (26h) to determine the status of the four main analog subsections. It is important to check the status of these subsections after Initialization, Cold Reset or the use of the powerdown modes in order to minimize the risk of distorting analog signals passed before the subsections are ready.

The 4 bits 14, 13, 12 and 11 indicate that the data in slots 1, 2, 3 and 4, respectively, are valid.

Table 10. SLOT 0, INPUT FRAME

Bit	Description	Comment	
15	Codec Ready Bit	1 =	AC Link Interface Ready
14	Slot 1 data valid	1 =	Valid Status Address or Slot Request
13	Slot 2 data valid	1 =	Valid Status Data

Table 10. SLOT 0, INPUT FRAME (continued)

Bit	Description	Comment	
12	Slot 3 data valid	1 =	Valid PCM Data (Left ADC)
11	Slot 4 data valid	1 =	Valid PCM Data (Right ADC)

SDATA_IN: Slot 1 – Status Address / Slot Request Bits

This slot echoes (in bits 18 – 12) the 7-bit address of the codec control/status register received from the controller as part of a read-request in the previous frame. If no read-request was received, the codec stuffs these bits with zeros.

Bits 11, 10 are Slot Request bits that support the Variable Rate Audio (VRA) capabilities of the LM4546B. For all codec Primary and Secondary modes, the left and right channels of the DAC take PCM data from slots 3 and 4 in the Output Frame respectively. The codec will therefore use bits 11 and 10 to request DAC data from these two slots. If bits 11 and 10 are set to 0, the controller should respond with valid PCM data in slots 3 and 4 of the next Output Frame. If bits 11 and 10 are set to 1, the controller should not send data.

The codec has full control of the slot request bits. By default, data is requested in every frame, corresponding to a sample rate equal to the frame rate (SYNC frequency) – 48 kHz when XTAL_IN = 24.576 MHz. To send samples at a rate below the frame rate, a controller should set VRA = 1 (bit 0 in the Extended Audio Control/Status register, 2Ah) and program the desired rate into the PCM DAC Rate register, 2Ch. Both DAC channels operate at the same sample rate. Values for common sample rates are given in the [Register Descriptions](#) section (Sample Rate Control Registers, 2Ch, 32h) but any rate between 4 kHz and 48 kHz (to a resolution of 1 Hz) is supported. Slot Requests from the LM4546B are issued completely deterministically. For example if a sample rate of 8000 Hz is programmed into 2Ch then the LM4546B will always issue a slot request in every sixth frame. A frequency of 9600 Hz will result in a request every fifth frame while a frequency of 8800 Hz will cause slot requests to be spaced alternately five and six frames apart. This determinism makes it easy to plan task scheduling on a system controller and simplifies application software development.

The LM4546B will ignore data in Output Frame slots that do not follow an Input Frame with a Slot Request. For example, if the LM4546B is expecting data at a 8000 Hz rate yet the AC '97 Digital Audio Controller continues to send data at 48000 Hz, then only those one-in-six audio samples that follow a Slot Request will be used by the DAC. The rest will be discarded.

Bits 9 – 2 are request bits for slots not used by the LM4546B and are stuffed with zeros. Bits 1 and 0 are reserved and are also stuffed with zeros.

Table 11. SLOT 1, INPUT FRAME

Bits	Description	Comment	
19	Reserved	Stuffed with "0" by LM4546B	
18:12	Status Register Index	Echo of the requested Status Register address	
11	Slot 3 Request bit (For left DAC PCM data)	0 =	Controller should send valid data in Slot 3 of the next Output Frame.
		1 =	Controller should not send Slot 3 data.
10	Slot 4 Request bit (For right DAC PCM data)	0 =	Controller should send valid data in Slot 4 of the next Output Frame.
		1 =	Controller should not send Slot 4 data.
9:2	Unused Slot Request bits	Stuffed with "0"s by LM4546B	
1,0	Reserved	Stuffed with "0"s by LM4546B	

SDATA_IN: Slot 2 – Status Data

This slot returns 16-bit status data read from a codec control/status register. The codec sends the data in the frame following a read-request by the controller (bit 15, slot 1 of the Output Frame). If no read-request was made in the previous frame the codec will stuff this slot with zeros.

Table 12. SLOT 2, INPUT FRAME

Bits	Description	Comment
19:4	Status Data	Data read from a codec control/status register. Stuffed with "0"s if no read-request in previous frame.
3:0	Reserved	Stuffed with "0"s by LM4546B

SDATA_IN: Slot 3 – PCM Record Left Channel

This slot contains sampled data from the left channel of the stereo ADC. The signal to be digitized is selected using the Record Select register (1Ah) and subsequently routed through the Record Select Mux and the Record Gain amplifier to the ADC.

This is a 20-bit slot and the digitized 18-bit PCM data is transmitted in an MSB justified format. The remaining 2 LSBs are stuffed with zeros.

Table 13. SLOT 3, INPUT FRAME

Bits	Description	Comment
19:2	PCM Record Left Channel data	18-bit PCM sample from left ADC
1:0	Reserved	Stuffed with "0"s by LM4546B

SDATA_IN: Slot 4 – PCM Record Right Channel

This slot contains sampled data from the right channel of the stereo ADC. The signal to be digitized is selected using the Record Select register (1Ah) and subsequently routed through the Record Select Mux and the Record Gain amplifier to the ADC.

This is a 20-bit slot and the digitized 18-bit PCM data is transmitted in an MSB justified format. The remaining 2 LSBs are stuffed with zeros.

Table 14. SLOT 4, INPUT FRAME

Bits	Description	Comment
19:2	PCM Record Right Channel data	18-bit PCM audio sample from right ADC
1:0	Reserved	Stuffed with "0"s by LM4546B

SDATA_IN: Slots 5 to 12 – Reserved

Slots 5 – 12 of the AC Link Input Frame are not used for data by the LM4546B and are always stuffed with zeros.

Register Descriptions

Default settings are indicated by *.

RESET REGISTER (00h)

Writing any value to this register causes a Register Reset which changes all registers back to their default values. If a read is performed on this register, the LM4546B will return a value of 0D40h. This value can be interpreted in accordance with the AC '97 specification to indicate that Texas Instruments 3D Sound is implemented and 18-bit data is supported for both the ADCs and DACs.

MASTER VOLUME REGISTER (02h)

This output register allows the output level from either channel of the stereo LINE_OUT to be muted or attenuated over the range 0 dB – 46.5 dB in nominal 1.5 dB steps. There are 6 bits of volume control for each channel and both stereo channels can be individually attenuated. The mute bit (D15) acts simultaneously on both stereo channels of LINE_OUT. The AC'97 specification states that "support for the MSB of the level is optional." All six bits may be written to the register, but if the MSB is a 1, the MSB is ignored and the register will be set to 0 11111. This will be the value when the register is read, allowing the software driver to detect whether the MSB is supported or not.

Mute	Mx5:Mx0	Function
0	0 00000	0 dB attenuation
0	0 11111	46.5 dB attenuation
0	1 xxxxx	As written
0	0 11111	As read back
1	X XXXXX	*mute
Default: 8000h		

MONO VOLUME REGISTER (06h)

This output register allows the level from MONO_OUT to be muted or attenuated over the range 0 dB – 46.5 dB in nominal 1.5 dB steps. There are 6bits of volume control and one mute bit (D15). All six bits may be written to the register, but if the MSB is a 1, the MSB is ignored and the register will be set to 0 11111. This will be the value when the register is read, allowing the software driver to detect whether the MSB is supported or not.

Mute	MM5:MM0	Function
0	0 00000	0 dB attenuation
0	0 11111	46.5 dB attenuation
0	1 xxxxx	As written
0	0 11111	As read back
1	X XXXXX	*mute
Default: 8000h		

PC BEEP VOLUME REGISTER (0Ah)

This input register adjusts the level of the mono PC_BEEP input to the stereo mixer MIX2 where it is summed equally into both channels of the Stereo Mix signal. PC_BEEP can be both muted and attenuated over a range of 0 dB to 45 dB in nominal 3 dB steps. Note that the **default setting for the PC_BEEP Volume register is 0 dB attenuation rather than mute.**

Mute	PV3:PV0	Function
0	0000	*0 dB attenuation
0	1111	45 dB attenuation
1	XXXX	mute
Default: 0000h		

MIXER INPUT VOLUME REGISTERS (Index 0Ch - 18h)

These input registers adjust the volume levels into the stereo mixers MIX1 and MIX2. Each channel may be adjusted over a range of +12 dB gain to –34.5 dB attenuation in 1.5 dB steps. For stereo ports, volumes of the left and right channels can be independently adjusted. Muting a given port is accomplished by setting the MSB to 1. Setting the MSB to 1 for stereo ports mutes both the left and right channel. The Mic Volume register (0Eh) controls an additional 20 dB boost for the selected microphone input by setting the 20dB bit (D6).

Mute	Gx4:Gx0	Function
0	0 0000	+12 dB gain
0	0 1000	0 dB gain
0	1 1111	34.5 dB attenuation
1	X XXXX	*mute
Default:	8008h (mono registers) 8808h (stereo registers)	

RECORD SELECT REGISTER (1Ah)

This register independently controls the sources for the right and left channels of the stereo ADC. The default value of 0000h corresponds to selecting the (mono) Mic input for both channels.

SL2:SL0	Source for Left Channel ADC
0	*Mic input
1	CD input (L)
2	Not used
3	Not used
4	LINE_IN input (L)
5	Stereo Mix (L)
6	Mono Mix
7	PHONE input

SR2:SR0	Source for Right Channel ADC
0	*Mic input
1	CD input (R)
2	Not used
3	Not used
4	LINE_IN input (R)
5	Stereo Mix (R)
6	Mono Mix
7	PHONE input

Default: 0000h

RECORD GAIN REGISTER (1Ch)

This register controls the input levels for both channels of the stereo ADC. The inputs come from the Record Select Mux and are selected via the Record Select Control register, 1Ah. The gain of each channel can be individually programmed from 0 dB to +22.5 dB in 1.5 dB steps. Both channels can also be muted by setting the MSB to 1.

Table 15. Record Gain Register (1Ch)

Mute	Gx3:Gx0	Function
0	1111	+22.5 dB gain
0	0000	0 dB gain
1	XXXX	*mute

Default: 8000h

GENERAL PURPOSE REGISTER (20h)

This register controls many miscellaneous functions implemented on the LM4546B. The miscellaneous control bits include POP which allows the DAC output to bypass the Texas Instruments 3D Sound circuitry, 3D which enables or disables the Texas Instruments 3D Sound circuitry, MIX which selects the MONO_OUT source, MS which controls the Microphone Selection mux, and LPBK which connects the 18 bit output of the stereo ADC to the 18 bit input of the stereo DAC, bypassing the Sample Rate Conversion (SRC) logic. LPBK provides a mixed-mode analog and digital loopback path between analog inputs and analog outputs.

BIT	Function			
POP	PCM Out Path:			
	<table border="0"> <tr> <td>*0 =</td> <td>3D allowed</td> </tr> <tr> <td>1 =</td> <td>3D bypassed</td> </tr> </table>	*0 =	3D allowed	1 =
*0 =	3D allowed			
1 =	3D bypassed			

BIT	Function	
3D	Texas Instruments 3D Sound:	*0 = off
		1 = on
MIX	Mono output select:	*0 = Mix
		1 = Mic
MS	Mic select:	*0 = MIC1
		1 = MIC2
LPBK	ADC/DAC Loopback:	*0 = No Loopback
		1 = Loopback
Default: 0000h		

3D CONTROL REGISTER (22h)

This read-only (0101h) register indicates, in accordance with the AC '97 Rev 2.1 Specification, the fixed depth and center characteristics of the Texas Instruments 3D Sound stereo enhancement.

POWERDOWN CONTROL / STATUS REGISTER (26h)

This read/write register is used both to monitor subsystem readiness and also to program the LM4546B powerdown states. The 4 LSBs indicate status and 6 of the 8 MSBs control powerdown.

The 4 LSBs of this register indicate the status of the 4 audio subsections of the codec: Reference voltage, Analog mixers and amplifiers, DAC section, ADC section. When the "Codec Ready" indicator bit in the AC Link Input Frame (SDATA_IN: slot 0, bit 15) is a "1", it indicates that the AC Link and AC '97 registers are in a fully operational state and that control and status information can be transferred. It does NOT indicate that the codec is ready to send or receive audio PCM data or to pass signals through the analog I/O and mixers. To determine that readiness, the Controller must check that the 4 LSBs of this register are set to "1" indicating that the appropriate audio subsections are ready.

The powerdown bits PR0 – PR5 control internal subsections of the codec. They are implemented in compliance with AC '97 Rev 2.1 to support the standard device power management states D0 – D3 as defined in the ACPI and PCI Bus Power Management specification.

PR0 controls the powerdown state of the ADC and associated sampling rate conversion circuitry. PR1 controls powerdown for the DAC and the DAC sampling rate conversion circuitry. PR2 powers down the mixer circuits (MIX1, MIX2, Texas Instruments 3D Sound, Mono Out, Line Out). PR3 powers down V_{REF} in addition to all the same mixer circuits as PR2. PR4 powers down the AC Link digital interface – see [Figure 17](#) for signal powerdown timing. PR5 disables internal clocks. PR6 and PR7 are not used.

BIT#	BIT	Function: Status	
0	ADC	1 =	ADC section ready to transmit data
1	DAC	1 =	DAC section ready to accept data
2	ANL	1 =	Analog mixers ready
3	REF	1 =	V_{REF} is up to nominal level

BIT#	BIT	Function: Powerdown	
8	PR0	1 =	Powerdown ADCs and Record Select Mux
9	PR1	1 =	Powerdown DACs
10	PR2	1 =	Powerdown Analog Mixer (V_{REF} still on)
11	PR3	1 =	Powerdown Analog Mixer (V_{REF} off)
12	PR4	1 =	Powerdown AC Link digital interface (BIT_CLK off)
13	PR5	1 =	Disable Internal Clock
14	PR6	Not Used	
15	PR7	Not Used	

Default: 000Fh If ready; otherwise 000Xh (see text)

EXTENDED AUDIO ID REGISTER (28h)

This read-only register (X001h) identifies which AC '97 Extended Audio features are supported. The LM4546B features VRA (Variable Rate Audio) and ID1, ID0 (Multiple Codec support). VRA is indicated by a "1" in bit 0. The two MSBs, ID1 and ID0, show the current Codec Identity as defined by the Identity pins ID1#, ID0# (pins 46 and 45). Note that the external logic connections to ID1#, ID0#, are inverse in polarity to the value of the Codec Identity (ID1, ID0) held in bits D15, D14. Codec mode selections are shown in the table below.

Pin 46 (ID1)	Pin 45 (ID0)	D15,28h (ID1)	D14,28h (ID0)	Codec Identity Mode
NC/DV _{DD}	NC/DV _{DD}	0	0	Primary
NC/DV _{DD}	GND	0	1	Secondary 1
GND	NC/DV _{DD}	1	0	Secondary 2
GND	GND	1	1	Secondary 3

EXTENDED AUDIO STATUS/CONTROL REGISTER (2Ah)

This read/write register provides status and control of the variable sample rate capabilities in the LM4546B. Setting the LSB of this register to "1" enables Variable Rate Audio (VRA) mode and allows DAC and ADC sample rates to be programmed via registers 2Ch and 32h respectively.

BIT	Function
VRA	*0 = VRA off (Frame-rate sampling) 1 = VRA on

Default: 0000h

SAMPLE RATE CONTROL REGISTERS (2Ch, 32h)

These read/write registers are used to set the sample rate for the left and right channels of the DAC (PCM DAC Rate, 2Ch) and the ADC (PCM ADC Rate, 32h). When Variable Rate Audio is enabled via bit 0 of the Extended Audio Control/Status register (2Ah), the sample rates can be programmed, in 1 Hz increments, to be any value from 4 kHz to 48 kHz. The value required is the hexadecimal representation of the desired sample rate, e.g. 8000₁₀ = 1F40h. Below is a list of the most common sample rates and the corresponding register (hex) values.

Table 16. Common Sample Rates

SR15:SR0	Sample Rate (Hz)
1F40h	8000
2B11h	11025
3E80h	16000
5622h	22050
AC44h	44100
*BB80h	*48000

VENDOR ID REGISTERS (7Ch – 7Eh)

These two read-only (4E53h, 4346h) registers contain Texas Instruments's Vendor ID and Texas Instruments's LM45xx codec version designation. The first 24 bits (4Eh, 53h, 43h) represent the three ASCII characters "NSC" which is Texas Instruments's Vendor ID for Microsoft's Plug and Play. The last 8 bits are the two binary coded decimal characters, 4, 6 and identify the codec to be an LM4546B.

RESERVED REGISTERS

Do not write to reserved registers. In particular, do not write to registers 24h, 5Ah, 74h and 7Ah. All registers not listed in the LM4546B Register Map are reserved. Reserved Registers will return 0000h if read.

Low Power Modes

The LM4546B provides 6 bits to control the powerdown state of internal analog and digital subsections and clocks. These 6 bits (PR0 – PR5) are located in the 8 MSBs of the Powerdown Control/Status register, 26h. The status of the four main analog subsections is given by the 4 LSBs in the same register, 26h.

The powerdown bits are implemented in compliance with AC '97 Rev 2.1 to support the standard device power management states D0 – D3 as defined in the ACPI and PCI Bus Power Management specification.

PR0 controls the powerdown state of the ADC and associated sampling rate conversion circuitry. PR1 controls powerdown for the DAC and the DAC sampling rate conversion circuitry. PR2 powers down the mixer circuits (MIX1, MIX2, Texas Instruments 3D Sound, Mono Out, Line Out). PR3 powers down V_{REF} in addition to all the same mixer circuits as PR2. PR4 powers down the AC Link Digital Interface – see Figure 17 for signal powerdown timing. PR5 disables internal clocks but leaves the crystal oscillator and BIT_CLK running (needed for minimum Primary mode powerdown dissipation in multi-codec systems). PR6 and PR7 are not used.

After a subsection has undergone a powerdown cycle, the appropriate status bit(s) in the Powerdown Control/Status register (26h) must be polled to confirm readiness. In particular the startup time of the V_{REF} circuitry depends on the value of the decoupling capacitors on pin 27 (3.3 μ F, 0.1 μ F in parallel is recommended) and this dependency is behind the requirement for both PR2 and PR3 functionality in AC '97 Rev 2.1.

When the AC Link Digital Interface is powered down the codec output signals SDATA_IN and BIT_CLK (Primary mode) are cleared to zero and no control data can be passed between controller and codec(s). This powerdown state can be cleared in two ways: Cold Reset (RESET# = 0) or Warm Reset (SYNC = 1, no BIT_CLK). Cold Reset sets all registers back to their default values (including clearing PR4) whereas Warm Reset only clears the PR4 bit and restarts the AC Link Digital Interface leaving all register contents otherwise unaffected. For Warm Reset (see Timing Diagrams), the SYNC input is used asynchronously. The LM4546B codec allows the AC Link digital interface powerdown state to be cleared immediately so that its duration can be essentially as short as T_{SH} , the Warm Reset pulse width. However for conformance with AC '97 Rev 2.1, Warm Reset should not be applied within 4 frame times of powerdown *i.e.* the AC Link powerdown state should be allowed to last at least 82.8 μ s.

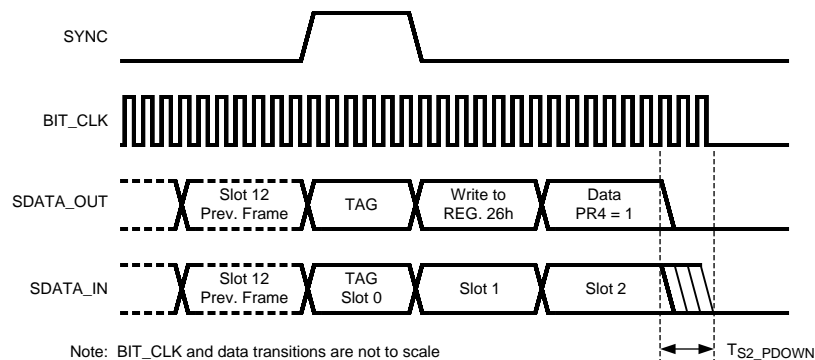

Figure 17. AC Link Powerdown Timing

Improving System Performance

The audio codec is capable of dynamic range performance in excess of 90 db., but the user must pay careful attention to several factors to achieve this. A primary consideration is keeping analog and digital grounds separate, and connecting them together in only one place. Some designers show the connection as a zero ohm resistor, which allows naming the nets separately. Although it is possible to use a two layer board, it is recommended that a minimum of four layers be used, with the two inside layers being analog ground and digital ground. If EMI is a system consideration, then as many as eight layers have been successfully used. The 12 and 25 MHz. clocks can have significant harmonic content depending on the rise and fall times. With the exception of the digital VDD pins, (covered later) bypass capacitors should be very close to the package. The analog VDD pins should be supplied from a separate regulator to reduce noise. By operating the digital portion on 3.3V instead of 5V, an additional 0.5-0.7 db improvement can be obtained.

The bandgap reference and the anti-pop slow turn-on circuit were improved in the LM4546B. A pullup resistor is not required on V_{REF} , pin 27. For an existing design, the 10 k Ω resistor can be left on the pc board, but the temperature coefficient will improve with no resistor on this pin. In addition, the THD will improve by 0.2–0.5 dB. The external capacitor is charged by an internal current source, ramping the voltage slowly. This results in slow turn-on of the audio stages, eliminating “pops and clicks”. Thus, turn-on performance is also improved. The pullup resistor, in conjunction with the internal impedance and the external capacitor, form a frequency dependent divider from the analog supply. Noise on the analog supply will be coupled into the audio path, with approximately 30 dB of attenuation. Although this is not a large amount if the noise on the supply is tens of millivolts, it will prevent SNR from exceeding 80 dB.

In [Figure 4](#) and [Figure 5](#), the input coupling capacitors are shown as 1 μ F capacitors. This is only necessary for extending the response down to 20 Hz. for music applications. For telematics or voice applications, the lower 3 dB can be much higher. Using a specified input resistance of 10 k Ω , (40 k Ω typical), a 0.1 μ F capacitor may be used. The lower 3 dB point will still be below 300 Hz. By using a smaller capacitor, the package size may be reduced, leading to a lower system cost.

Backwards Compatibility

The LM4546B is improved compared to the LM4546A. If it is required to build a board that will use either part, a 10 k Ω resistor must be added from the V_{REF} pin (pin 27) to AV_{DD} for the LM4546A. It is not required for the LM4546B. Addition of this resistor will slightly increase the temperature coefficient of the internal bandgap reference and slightly decrease the THD performance, but overall performance will still be better than the LM4546A.

The LM4546A requires that pins 1 and 9 (DV_{DD}) connect directly to a 27 nH inductor before going to the 3.3 Volt digital supply and bypass capacitors. The inductor is not required for the LM4546B and should not be used.

Multiple Codecs

EXTENDED AC LINK

Up to four codecs can be supported on the extended AC Link. These multiple codec implementations should run off a common BIT_CLK generated by the Primary Codec. All codecs share the AC '97 Digital Controller output signals, SYNC, SDATA_OUT, and RESET#. Each codec, however, supplies its own SDATA_IN signal back to the controller, with the result that the controller requires one dedicated input pin per codec ([Figure 18](#)).

By definition there can be one Primary Codec and up to three Secondary Codecs on an extended AC Link. The Primary Codec has a Codec Identity = (ID1, ID0) = ID = 00 while Secondary Codecs take identities equal to 01, 10 or 11. The Codec Identity is used as a chip select function. This allows the Command and Status registers in any of the codecs to be individually addressed although the access mechanism for Secondary Codecs differs slightly from that for a Primary.

The Identity control pins, ID1, ID0 (pins 46 and 45) are internally pulled up to DV_{DD} . The Codec may therefore be configured as 'Primary' either by leaving ID1, ID0 open (NC) or by strapping them externally to DV_{DD} (Digital supply).

The difference between Primary and Secondary codec modes is in their timing source and in the Tag Bit handling in Output Frames for Command/Status register access. For a timing source, a Primary codec divides down by 2 the frequency of the signal on XTAL_IN and also generates this as the BIT_CLK output for the use of the controller and any Secondary codecs. Secondary codecs use BIT_CLK as an input and as their timing source and do not use XTAL_IN or XTAL_OUT. The use of Tag Bits is described below.

SECONDARY CODEC REGISTER ACCESS

For Secondary Codec access, the controller must set the tag bits for Command Address and Data in the Output Frame as invalid (*i.e.* equal to 0). The Command Address and Data tag bits are in slot 0, bits 14 and 13 and Output Frames are those in the SDATA_OUT signal from controller to codec. The controller must also place the non-zero value (01, 10, or 11) corresponding to the Identity (ID1, ID0) of the target Secondary Codec into the Codec ID field (slot 0, bits 1 and 0) in that same Output Frame. The value set in the Codec ID field determines which of the three possible Secondary Codecs is accessed. Unlike a Primary Codec, a Secondary Codec will disregard the Command Address and Data tag bits when there is a match between the 2-bit Codec ID value (slot 0, bits 1 and 0) and the Codec Identity (ID1, ID0). Instead it uses the Codec-ID/Identity match to indicate that the Command Address in slot 1 and (if a “write”) the Command Data in slot 2 are valid.

When reading from a Secondary Codec, the controller must send the correct Codec ID bits (*i.e.* the target Codec Identity in slot 0, bits 1 and 0) along with the read-request bit (slot 1, bit 19) and target register address (slot 1, bits 18 – 12). To write to a Secondary Codec, a controller must send the correct Codec ID bits when slot 1 contains a valid target register address and “write” indicator bit and slot 2 contains valid target register data. A write operation is only valid if the register address and data are both valid and sent within the same frame. When accessing the Primary Codec, the Codec ID bits are cleared and the tag bits 14 and 13 resume their role indicating the validity of Command Address and Data in slots 1 and 2.

The use of the tag bits in Input Frames (carried by the SDATA_IN signal) is the same for Primary and Secondary Codecs.

The Codec Identity is determined by the input pins ID1#, ID0# (pins 46 and 45) and can be read as the value of the ID1, ID0 bits (D15, D14) in the Extended Audio ID register, 28h of the target codec.

Slots in the AC Link Output Frame are always mapped to carry data to the left DAC channel in slot 3 and data to the right DAC channel in slot 4. Similarly, slots in AC Link Input Frames are always mapped such that PCM data from the left ADC channel is carried by slot 3 and PCM data from the right ADC channel by slot 4. Output Frames are those carried by the SDATA_OUT signal from the controller to the codec while Input Frames are those carried by the SDATA_IN signal from the codec to the controller.

SLOT 0: TAG bits in Output Frames (controller to codec)

Bit 15	14	13	12	11	10	9	8	7	6	5	4	3	2	1	0
Valid Frame	Slot 1 Valid	Slot 2 Valid	Slot 3 Valid	Slot 4 Valid	X	X	X	X	X	X	X	X	X	ID1	ID0

Extended Audio ID register (28h): Support for Multiple Codecs

Reg	Name	D15	D14	D13	D12	D11	D10	D9	D8	D7	D6	D5	D4	D3	D2	D1	D0	Default
28h	Extended Audio ID	ID1	ID0	X	X	X	X	X	X	X	X	X	X	X	X	X	VRA	X001h

Test Modes

AC '97 Rev 2.1 defines two test modes: ATE test mode and Vendor test mode. Cold Reset is the only way to exit either of them. The ATE test mode is activated if SDATA_OUT is sampled high by the trailing edge (zero-to-one transition) of RESET#. In ATE test mode the codec AC Link outputs SDATA_IN and BIT_CLK are then configured to a high impedance state to allow tester control of the AC Link interface for controller testing. ATE test mode timing parameters are given in the [Electrical Characteristics](#) table. The Vendor test mode is entered if SYNC is sampled high by the zero-to-one transition of RESET#. Neither of these entry conditions can occur in normal AC Link operation but care must be taken to avoid mistaken activation of the test modes when using non standard controllers.

REVISION HISTORY

Changes from Revision E (May 2013) to Revision F	Page
• Changed layout of National Data Sheet to TI format	30

PACKAGING INFORMATION

Orderable Device	Status (1)	Package Type	Package Drawing	Pins	Package Qty	Eco Plan (2)	Lead/Ball Finish (6)	MSL Peak Temp (3)	Op Temp (°C)	Device Marking (4/5)	Samples
LM4546BVH/NOPB	ACTIVE	LQFP	PT	48	250	Green (RoHS & no Sb/Br)	CU SN	Level-3-260C-168 HR	-40 to 85	LM4546 BVH	Samples
LM4546BVHX/NOPB	ACTIVE	LQFP	PT	48	1000	Green (RoHS & no Sb/Br)	CU SN	Level-3-260C-168 HR	-40 to 85	LM4546 BVH	Samples

(1) The marketing status values are defined as follows:

ACTIVE: Product device recommended for new designs.

LIFEBUY: TI has announced that the device will be discontinued, and a lifetime-buy period is in effect.

NRND: Not recommended for new designs. Device is in production to support existing customers, but TI does not recommend using this part in a new design.

PREVIEW: Device has been announced but is not in production. Samples may or may not be available.

OBSOLETE: TI has discontinued the production of the device.

(2) Eco Plan - The planned eco-friendly classification: Pb-Free (RoHS), Pb-Free (RoHS Exempt), or Green (RoHS & no Sb/Br) - please check <http://www.ti.com/productcontent> for the latest availability information and additional product content details.

TBD: The Pb-Free/Green conversion plan has not been defined.

Pb-Free (RoHS): TI's terms "Lead-Free" or "Pb-Free" mean semiconductor products that are compatible with the current RoHS requirements for all 6 substances, including the requirement that lead not exceed 0.1% by weight in homogeneous materials. Where designed to be soldered at high temperatures, TI Pb-Free products are suitable for use in specified lead-free processes.

Pb-Free (RoHS Exempt): This component has a RoHS exemption for either 1) lead-based flip-chip solder bumps used between the die and package, or 2) lead-based die adhesive used between the die and leadframe. The component is otherwise considered Pb-Free (RoHS compatible) as defined above.

Green (RoHS & no Sb/Br): TI defines "Green" to mean Pb-Free (RoHS compatible), and free of Bromine (Br) and Antimony (Sb) based flame retardants (Br or Sb do not exceed 0.1% by weight in homogeneous material)

(3) MSL, Peak Temp. - The Moisture Sensitivity Level rating according to the JEDEC industry standard classifications, and peak solder temperature.

(4) There may be additional marking, which relates to the logo, the lot trace code information, or the environmental category on the device.

(5) Multiple Device Markings will be inside parentheses. Only one Device Marking contained in parentheses and separated by a "~" will appear on a device. If a line is indented then it is a continuation of the previous line and the two combined represent the entire Device Marking for that device.

(6) Lead/Ball Finish - Orderable Devices may have multiple material finish options. Finish options are separated by a vertical ruled line. Lead/Ball Finish values may wrap to two lines if the finish value exceeds the maximum column width.

Important Information and Disclaimer: The information provided on this page represents TI's knowledge and belief as of the date that it is provided. TI bases its knowledge and belief on information provided by third parties, and makes no representation or warranty as to the accuracy of such information. Efforts are underway to better integrate information from third parties. TI has taken and continues to take reasonable steps to provide representative and accurate information but may not have conducted destructive testing or chemical analysis on incoming materials and chemicals. TI and TI suppliers consider certain information to be proprietary, and thus CAS numbers and other limited information may not be available for release.

In no event shall TI's liability arising out of such information exceed the total purchase price of the TI part(s) at issue in this document sold by TI to Customer on an annual basis.

TAPE AND REEL INFORMATION

QUADRANT ASSIGNMENTS FOR PIN 1 ORIENTATION IN TAPE

*All dimensions are nominal

Device	Package Type	Package Drawing	Pins	SPQ	Reel Diameter (mm)	Reel Width W1 (mm)	A0 (mm)	B0 (mm)	K0 (mm)	P1 (mm)	W (mm)	Pin1 Quadrant
LM4546BVHX/NOPB	LQFP	PT	48	1000	330.0	16.4	9.3	9.3	2.2	12.0	16.0	Q2

TAPE AND REEL BOX DIMENSIONS



*All dimensions are nominal

Device	Package Type	Package Drawing	Pins	SPQ	Length (mm)	Width (mm)	Height (mm)
LM4546BVHX/NOPB	LQFP	PT	48	1000	367.0	367.0	38.0

PT (S-PQFP-G48)

PLASTIC QUAD FLATPACK

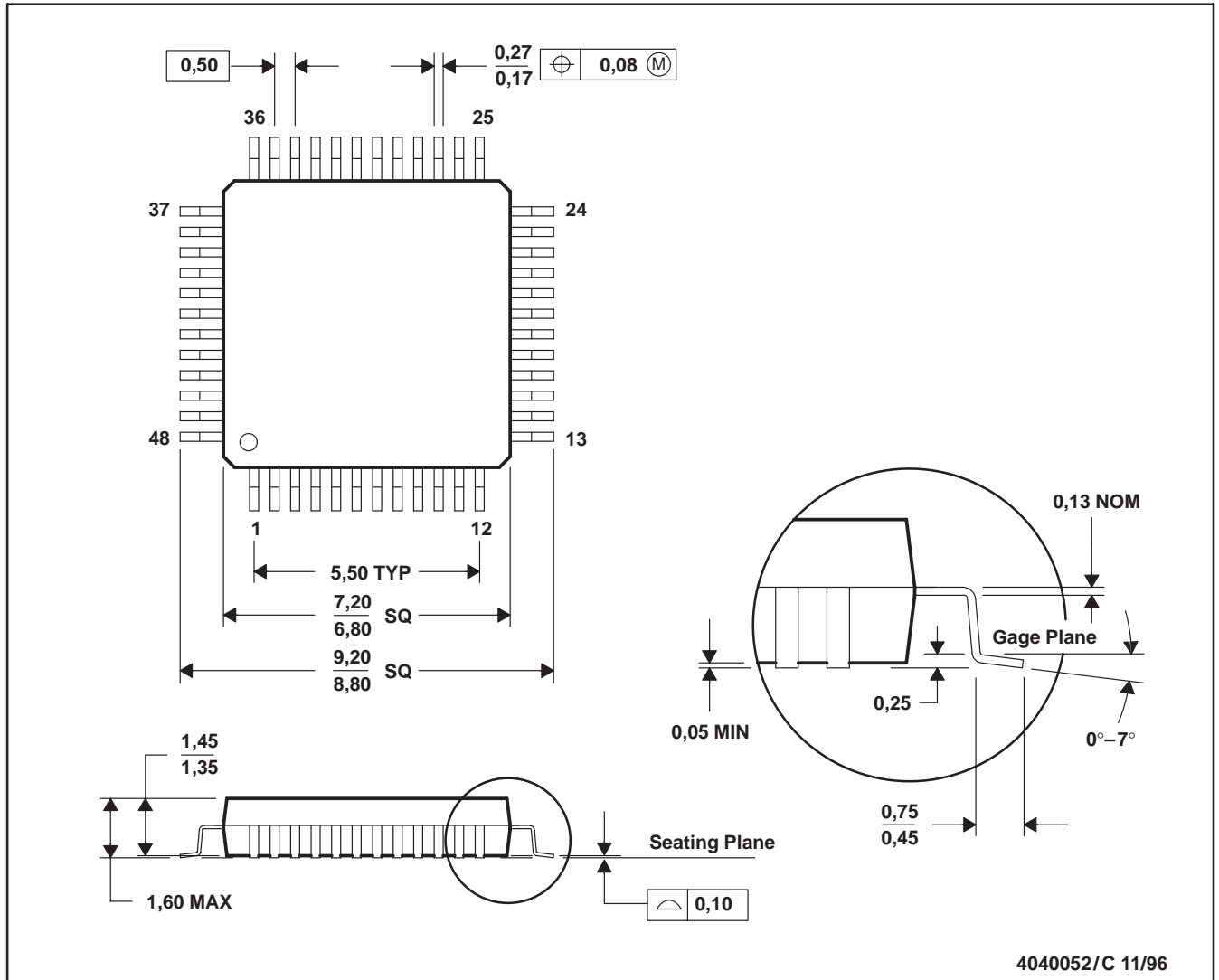

- NOTES: A. All linear dimensions are in millimeters.
 B. This drawing is subject to change without notice.
 C. Falls within JEDEC MS-026
 D. This may also be a thermally enhanced plastic package with leads connected to the die pads.

IMPORTANT NOTICE

Texas Instruments Incorporated (TI) reserves the right to make corrections, enhancements, improvements and other changes to its semiconductor products and services per JESD46, latest issue, and to discontinue any product or service per JESD48, latest issue. Buyers should obtain the latest relevant information before placing orders and should verify that such information is current and complete.

TI's published terms of sale for semiconductor products (<http://www.ti.com/sc/docs/stdterms.htm>) apply to the sale of packaged integrated circuit products that TI has qualified and released to market. Additional terms may apply to the use or sale of other types of TI products and services.

Reproduction of significant portions of TI information in TI data sheets is permissible only if reproduction is without alteration and is accompanied by all associated warranties, conditions, limitations, and notices. TI is not responsible or liable for such reproduced documentation. Information of third parties may be subject to additional restrictions. Resale of TI products or services with statements different from or beyond the parameters stated by TI for that product or service voids all express and any implied warranties for the associated TI product or service and is an unfair and deceptive business practice. TI is not responsible or liable for any such statements.

Buyers and others who are developing systems that incorporate TI products (collectively, "Designers") understand and agree that Designers remain responsible for using their independent analysis, evaluation and judgment in designing their applications and that Designers have full and exclusive responsibility to assure the safety of Designers' applications and compliance of their applications (and of all TI products used in or for Designers' applications) with all applicable regulations, laws and other applicable requirements. Designer represents that, with respect to their applications, Designer has all the necessary expertise to create and implement safeguards that (1) anticipate dangerous consequences of failures, (2) monitor failures and their consequences, and (3) lessen the likelihood of failures that might cause harm and take appropriate actions. Designer agrees that prior to using or distributing any applications that include TI products, Designer will thoroughly test such applications and the functionality of such TI products as used in such applications.

TI's provision of technical, application or other design advice, quality characterization, reliability data or other services or information, including, but not limited to, reference designs and materials relating to evaluation modules, (collectively, "TI Resources") are intended to assist designers who are developing applications that incorporate TI products; by downloading, accessing or using TI Resources in any way, Designer (individually or, if Designer is acting on behalf of a company, Designer's company) agrees to use any particular TI Resource solely for this purpose and subject to the terms of this Notice.

TI's provision of TI Resources does not expand or otherwise alter TI's applicable published warranties or warranty disclaimers for TI products, and no additional obligations or liabilities arise from TI providing such TI Resources. TI reserves the right to make corrections, enhancements, improvements and other changes to its TI Resources. TI has not conducted any testing other than that specifically described in the published documentation for a particular TI Resource.

Designer is authorized to use, copy and modify any individual TI Resource only in connection with the development of applications that include the TI product(s) identified in such TI Resource. NO OTHER LICENSE, EXPRESS OR IMPLIED, BY ESTOPPEL OR OTHERWISE TO ANY OTHER TI INTELLECTUAL PROPERTY RIGHT, AND NO LICENSE TO ANY TECHNOLOGY OR INTELLECTUAL PROPERTY RIGHT OF TI OR ANY THIRD PARTY IS GRANTED HEREIN, including but not limited to any patent right, copyright, mask work right, or other intellectual property right relating to any combination, machine, or process in which TI products or services are used. Information regarding or referencing third-party products or services does not constitute a license to use such products or services, or a warranty or endorsement thereof. Use of TI Resources may require a license from a third party under the patents or other intellectual property of the third party, or a license from TI under the patents or other intellectual property of TI.

TI RESOURCES ARE PROVIDED "AS IS" AND WITH ALL FAULTS. TI DISCLAIMS ALL OTHER WARRANTIES OR REPRESENTATIONS, EXPRESS OR IMPLIED, REGARDING RESOURCES OR USE THEREOF, INCLUDING BUT NOT LIMITED TO ACCURACY OR COMPLETENESS, TITLE, ANY EPIDEMIC FAILURE WARRANTY AND ANY IMPLIED WARRANTIES OF MERCHANTABILITY, FITNESS FOR A PARTICULAR PURPOSE, AND NON-INFRINGEMENT OF ANY THIRD PARTY INTELLECTUAL PROPERTY RIGHTS. TI SHALL NOT BE LIABLE FOR AND SHALL NOT DEFEND OR INDEMNIFY DESIGNER AGAINST ANY CLAIM, INCLUDING BUT NOT LIMITED TO ANY INFRINGEMENT CLAIM THAT RELATES TO OR IS BASED ON ANY COMBINATION OF PRODUCTS EVEN IF DESCRIBED IN TI RESOURCES OR OTHERWISE. IN NO EVENT SHALL TI BE LIABLE FOR ANY ACTUAL, DIRECT, SPECIAL, COLLATERAL, INDIRECT, PUNITIVE, INCIDENTAL, CONSEQUENTIAL OR EXEMPLARY DAMAGES IN CONNECTION WITH OR ARISING OUT OF TI RESOURCES OR USE THEREOF, AND REGARDLESS OF WHETHER TI HAS BEEN ADVISED OF THE POSSIBILITY OF SUCH DAMAGES.

Unless TI has explicitly designated an individual product as meeting the requirements of a particular industry standard (e.g., ISO/TS 16949 and ISO 26262), TI is not responsible for any failure to meet such industry standard requirements.

Where TI specifically promotes products as facilitating functional safety or as compliant with industry functional safety standards, such products are intended to help enable customers to design and create their own applications that meet applicable functional safety standards and requirements. Using products in an application does not by itself establish any safety features in the application. Designers must ensure compliance with safety-related requirements and standards applicable to their applications. Designer may not use any TI products in life-critical medical equipment unless authorized officers of the parties have executed a special contract specifically governing such use. Life-critical medical equipment is medical equipment where failure of such equipment would cause serious bodily injury or death (e.g., life support, pacemakers, defibrillators, heart pumps, neurostimulators, and implantables). Such equipment includes, without limitation, all medical devices identified by the U.S. Food and Drug Administration as Class III devices and equivalent classifications outside the U.S.

TI may expressly designate certain products as completing a particular qualification (e.g., Q100, Military Grade, or Enhanced Product). Designers agree that it has the necessary expertise to select the product with the appropriate qualification designation for their applications and that proper product selection is at Designers' own risk. Designers are solely responsible for compliance with all legal and regulatory requirements in connection with such selection.

Designer will fully indemnify TI and its representatives against any damages, costs, losses, and/or liabilities arising out of Designer's non-compliance with the terms and provisions of this Notice.

Looking for pricing, stock, or lifecycle information?

Click below to explore more details on WIN SOURCE:

 [View LM4546BVHX/NOPB on WIN SOURCE](#)

 [Texas Instruments](#) Information

Optimize Your Supply Chain with WIN SOURCE Solutions

-  Global Sourcing Solution
-  Obsolete Management
-  Cost Control Management
-  Shortage Management
-  Alternative Solution
-  Excess Inventory Management