



**THE DATASHEET OF  
LM3881MMX/NOPB**



## LM3881 Simple Power Sequencer With Adjustable Timing

### 1 Features

- Easiest Method to Sequence Rails
- Power-Up and Power-Down Control
- Tiny Footprint
- Low Quiescent Current of 80  $\mu$ A
- Input Voltage Range of 2.7 V to 5.5 V
- Output Invert Feature
- Timing Controlled by Small Value External Capacitor

### 2 Applications

- Security Cameras
- Servers
- Networking Elements
- FPGA Sequencing
- Microprocessor and Microcontroller Sequencing
- Multiple Supply Sequencing

### 3 Description

The LM3881 Simple Power Sequencer offers the easiest method to control power up and power down of multiple power supplies (switching or linear regulators). By staggering the start-up sequence, it is possible to avoid latch conditions or large inrush currents that can affect the reliability of the system.

Available in VSSOP-8 package, the Simple Sequencer contains a precision enable pin and three open-drain output flags. When the LM3881 is enabled, the three output flags will sequentially release, after individual time delays, thus permitting the connected power supplies to start up. The output flags will follow a reverse sequence during power down to avoid latch conditions. Time delays are defined using an external capacitor and the output flag states can be inverted by the user.

#### Device Information<sup>(1)</sup>

PART NUMBER	PACKAGE	BODY SIZE (NOM)
LM3881	VSSOP (8)	3.00 mm x 3.00 mm

(1) For all available packages, see the orderable addendum at the end of the datasheet.

#### Typical System Application

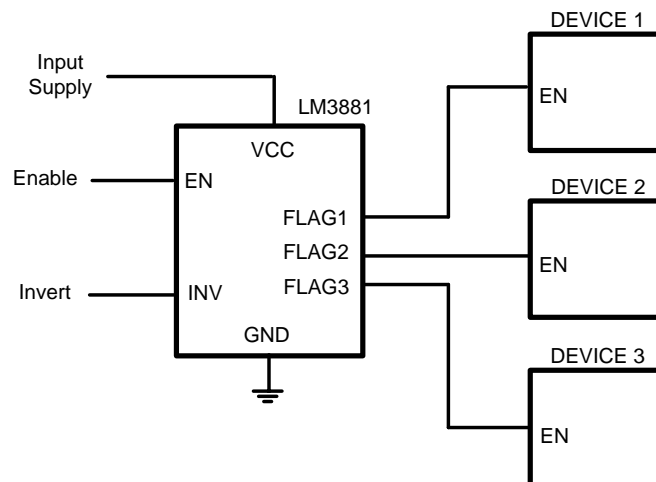

## Table of Contents

<b>1 Features</b> ..... 1 <b>2 Applications</b> ..... 1 <b>3 Description</b> ..... 1 <b>4 Revision History</b> ..... 2 <b>5 Pin Configuration and Functions</b> ..... 3 <b>6 Specifications</b> ..... 4 6.1 Absolute Maximum Ratings ..... 4 6.2 Handling Ratings ..... 4 6.3 Recommended Operating Conditions ..... 4 6.4 Thermal Information ..... 4 6.5 Electrical Characteristics ..... 5 6.6 Typical Characteristics ..... 6 <b>7 Detailed Description</b> ..... 8 7.1 Overview ..... 8 7.2 Functional Block Diagram ..... 8	7.3 Feature Description ..... 8 7.4 Device Functional Modes ..... 13 <b>8 Application and Implementation</b> ..... 15 8.1 Application Information ..... 15 8.2 Typical Application ..... 15 <b>9 Power Supply Recommendations</b> ..... 18 <b>10 Layout</b> ..... 18 10.1 Layout Guidelines ..... 18 10.2 Layout Example ..... 18 <b>11 Device and Documentation Support</b> ..... 20 11.1 Device Support ..... 20 11.2 Trademarks ..... 20 11.3 Electrostatic Discharge Caution ..... 20 11.4 Glossary ..... 20 <b>12 Mechanical, Packaging, and Orderable Information</b> ..... 20
-----------------------------------------------------------------------------------------------------------------------------------------------------------------------------------------------------------------------------------------------------------------------------------------------------------------------------------------------------------------------------------------------------------------------------------------------------------------------------------------------------------------------------------------------------------------------------	--------------------------------------------------------------------------------------------------------------------------------------------------------------------------------------------------------------------------------------------------------------------------------------------------------------------------------------------------------------------------------------------------------------------------------------------------------------------------------------------------------------------------------------------------------------------------------------------------------------------------------

## 4 Revision History

NOTE: Page numbers for previous revisions may differ from page numbers in the current version.

Changes from Revision C (April 2013) to Revision D	Page
<ul style="list-style-type: none"> <li>• Added <i>Handling Rating</i> table, <i>Feature Description</i> section, <i>Device Functional Modes</i>, <i>Application and Implementation</i> section, <i>Power Supply Recommendations</i> section, <i>Layout</i> section, <i>Device and Documentation Support</i> section, and <i>Mechanical, Packaging, and Orderable Information</i> section</li> </ul>	4

Changes from Revision B (April 2013) to Revision C	Page
<ul style="list-style-type: none"> <li>• Changed layout of National Data Sheet to TI format</li> </ul>	13

## 5 Pin Configuration and Functions

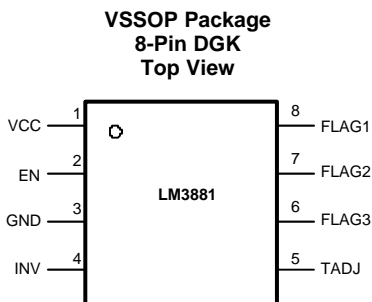

### Pin Functions

PIN		I/O	DESCRIPTION
NAME	NO.		
VCC	1	I	Input Supply
EN	2	I	Precision Enable
GND	3	–	Ground
INV	4	I	Output Logic Invert
TADJ	5	O	Timer Adjust
FLAG3	6	O	Open-Drain Output 3
FLAG2	7	O	Open-Drain Output 2
FLAG1	8	O	Open-Drain Output 1

## 6 Specifications

### 6.1 Absolute Maximum Ratings

over operating free-air temperature (unless otherwise noted) <sup>(1)(2)</sup>

	MIN	MAX	UNIT
VCC, EN, INV, TADJ, FLAG1, FLAG2, FLAG3 to GND	-0.3	6.0	V
Junction Temperature		150	°C
Lead Temperature (Soldering, 5 s)		260	°C

- (1) Stresses beyond those listed under *Absolute Maximum Ratings* may cause permanent damage to the device. These are stress ratings only, which do not imply functional operation of the device at these or any other conditions beyond those indicated under *Recommended Operating Conditions*. Exposure to absolute-maximum-rated conditions for extended periods may affect device reliability.
- (2) If Military/Aerospace specified devices are required, please contact the Texas Instruments Sales Office/Distributors for availability and specifications.

### 6.2 Handling Ratings

	MIN	MAX	UNIT
T <sub>stg</sub> Storage temperature range	-65	150	°C
V <sub>(ESD)</sub> Electrostatic discharge Human body model (HBM), per ANSI/ESDA/JEDEC JS-001, all pins <sup>(1)</sup>		2	kV

- (1) JEDEC document JEP155 states that 500-V HBM allows safe manufacturing with a standard ESD control process.

### 6.3 Recommended Operating Conditions

over operating free-air temperature range (unless otherwise noted)

	MIN	MAX	UNIT
VCC to GND	2.7	5.5	V
EN, INV, TADJ, FLAG1, FLAG2, FLAG3 to GND	-0.3	VCC + 0.3	V
Junction Temperature	-40	125	°C

### 6.4 Thermal Information

THERMAL METRIC <sup>(1)</sup>		LM3881	UNIT
		DGK	
		8 PINS	
R <sub>θJA</sub>	Junction-to-ambient thermal resistance	224.5	°C/W
R <sub>θJC(top)</sub>	Junction-to-case (top) thermal resistance	107.6	
R <sub>θJB</sub>	Junction-to-board thermal resistance	145.3	
Ψ <sub>JT</sub>	Junction-to-top characterization parameter	31.8	
Ψ <sub>JB</sub>	Junction-to-board characterization parameter	143.7	

- (1) For more information about traditional and new thermal metrics, see the *IC Package Thermal Metrics* application report, [SPRA953](http://www.ti.com/lit/an/spra953).

## 6.5 Electrical Characteristics

over operating free-air temperature range (unless otherwise noted). Minimum and Maximum limits are ensured through test, design or statistical correlation. Typical values represent the most likely parametric norm at  $T_J = 25^\circ\text{C}$  and are provided for reference purposes only.  $T_J = -40^\circ\text{C}$  to  $+125^\circ\text{C}$ ,  $V_{CC} = 3.3\text{ V}$ , unless otherwise specified.

PARAMETER	TEST CONDITIONS	MIN <sup>(1)</sup>	TYP <sup>(2)</sup>	MAX <sup>(1)</sup>	UNIT	
$I_Q$	Operating Quiescent Current		80	110	$\mu\text{A}$	
<b>OPEN-DRAIN FLAGS</b>						
$I_{\text{FLAG}}$	FLAGx Leakage Current	$V_{\text{FLAGx}} = 3.3\text{ V}$	0.001	1	$\mu\text{A}$	
$V_{\text{OL}}$	FLAGx Output Voltage Low	$I_{\text{FLAGx}} = 1.2\text{ mA}$		0.4	V	
<b>TIME DELAYS</b>						
$I_{\text{TADJ\_SRC}}$	TADJ Source Current		4	12	20	$\mu\text{A}$
$I_{\text{TADJ\_SNK}}$	TADJ Sink Current		4	12	20	$\mu\text{A}$
$V_{\text{HTH}}$	High Threshold Level		1.0	1.22	1.4	V
$V_{\text{LTH}}$	Low Threshold Level		0.3	0.5	0.7	V
$T_{\text{CLK}}$	Clock Cycle	$C_{\text{ADJ}} = 10\text{ nF}$		1.2		ms
$T_{\text{D1}}, T_{\text{D4}}$	Flag Time Delay		9		10	Clock cycles
$T_{\text{D2}}, T_{\text{D3}}, T_{\text{D5}}, T_{\text{D6}}$	Flag Time Delay			8		Clock cycles
<b>ENABLE PIN</b>						
$V_{\text{EN}}$	EN Pin Threshold		1.0	1.22	1.5	V
$I_{\text{EN}}$	EN Pin Pullup Current	$V_{\text{EN}} = 0\text{ V}$		7		$\mu\text{A}$
<b>INV PIN</b>						
$V_{\text{IH\_INV}}$	Invert Pin $V_{\text{IH}}$		90% VCC			V
$V_{\text{IL\_INV}}$	Invert Pin $V_{\text{IL}}$				10% VCC	V

- (1) Limits are 100% production tested at  $25^\circ\text{C}$ . Limits over the operating temperature range are ensured through correlation using Statistical Quality Control (SQC) methods. The limits are used to calculate TI's Average Outgoing Quality Level (AOQL).
- (2) Typical numbers are at  $25^\circ\text{C}$  and represent the most likely parametric norm.

### 6.6 Typical Characteristics

V<sub>CC</sub> = 3.3 V unless otherwise specified.

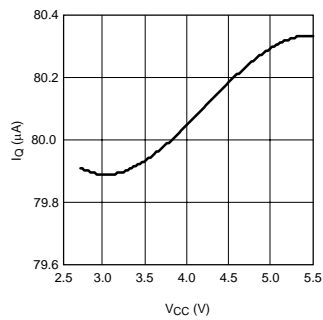

Figure 1. Quiescent Current vs V<sub>CC</sub>

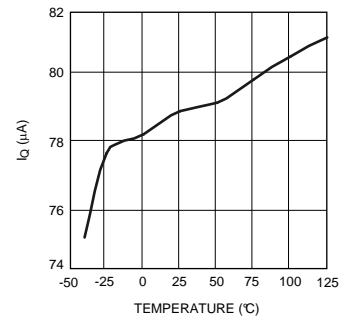

Figure 2. Quiescent Current vs Temperature

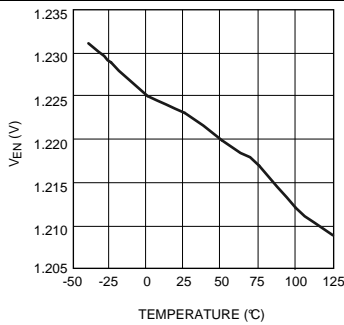

Figure 3. Enable Threshold vs Temperature

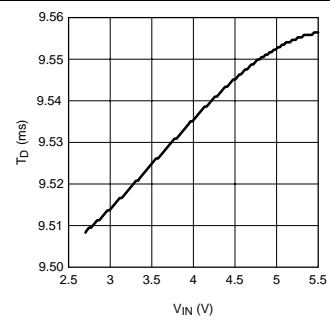

Figure 4. Time Delay vs V<sub>IN</sub> (C<sub>ADJ</sub> = 10 nF Nominal)

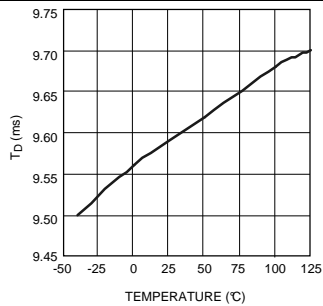

Figure 5. Time Delay vs Temperature (C<sub>ADJ</sub> = 10 nF Nominal)

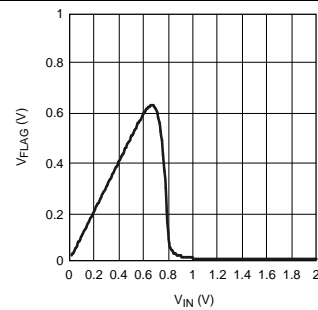
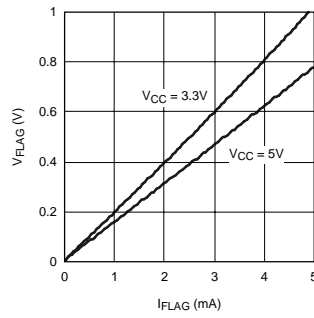

Figure 6. V<sub>FLAG</sub> vs V<sub>IN</sub> (INV Low, R<sub>FLAG</sub> = 100 kΩ)

**Typical Characteristics (continued)**

$V_{CC} = 3.3\text{ V}$  unless otherwise specified.



**Figure 7. FLAG Voltage vs Current**

## 7 Detailed Description

### 7.1 Overview

The LM3881 Simple Power Sequencer provides a simple solution for sequencing multiple rails in a controlled manner. An established clock signal facilitates control of the power up and power down of three open-drain FET output flags. These flags permit connection to shutdown or enable pins of linear regulators and/or switching regulators to control the operation of the power supplies. This allows design of a complete power system without the concern of large inrush currents or latch-up conditions that can occur during an uncontrolled startup. An invert (INV) pin reverses the logic of the output flags. This pin should be tied to a logic output high or low and not allowed to remain open circuit. The following discussion assumes the INV pin is held low such that the flag output is active high.

### 7.2 Functional Block Diagram

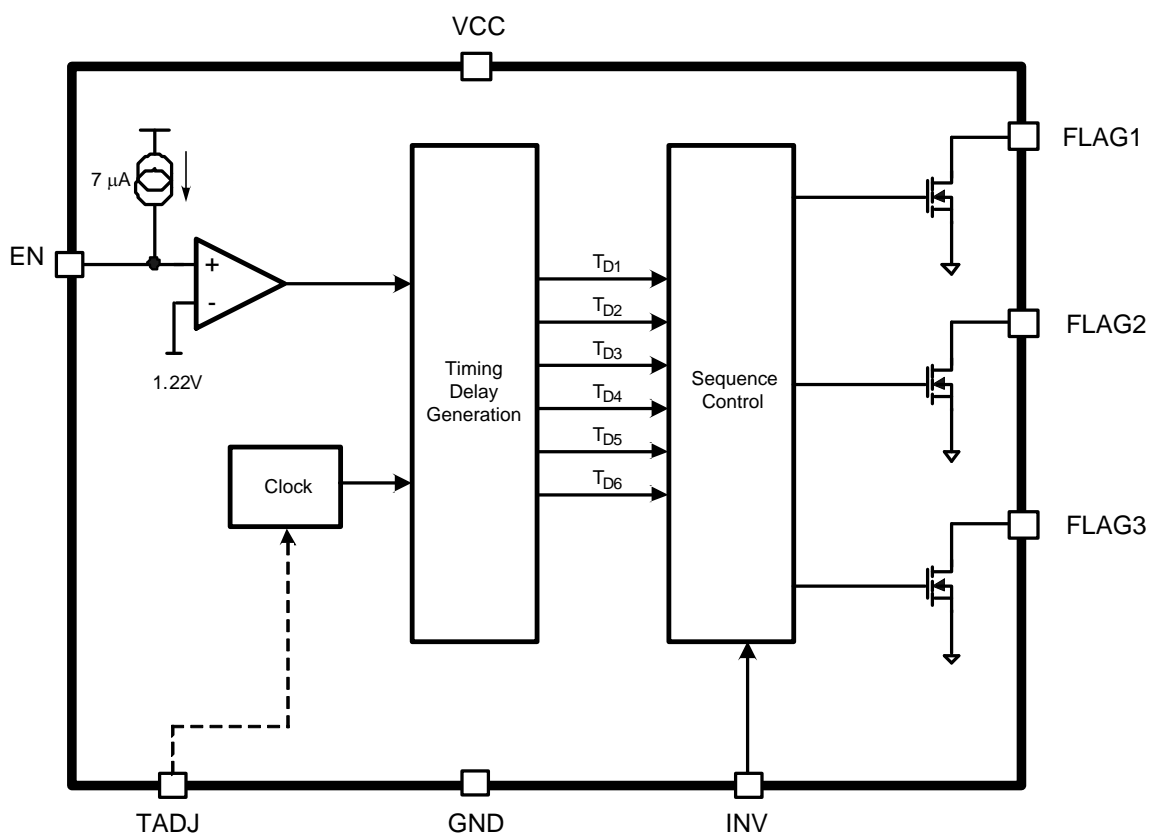

### 7.3 Feature Description

#### 7.3.1 Adjustable Timing

A small external timing capacitor is connected to the TADJ pin that establishes the clock waveform. This capacitor is linearly charged/discharged by a fixed current source/sink, denoted  $I_{TADJ\_SRC}$  /  $I_{TADJ\_SNK}$ , of magnitude 12  $\mu\text{A}$  between predefined voltage threshold levels, denoted  $V_{LTH}$  and  $V_{HTH}$ , to generate the timing waveform as shown in [Figure 8](#).

Feature Description (continued)

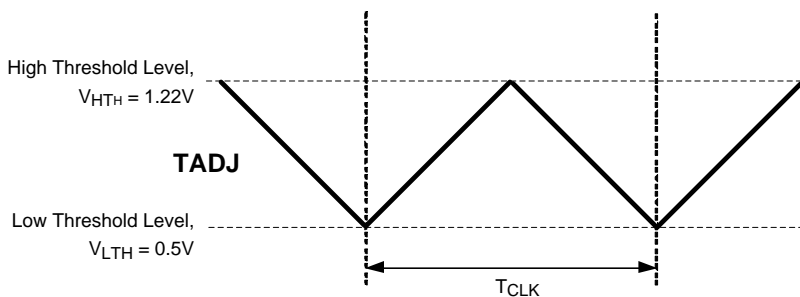

Figure 8. TADJ Pin Timing Waveform

Thus, the clock cycle duration is directly proportional to the timing capacitor value. Considering the TADJ voltage threshold levels and the charge/discharge current magnitude, it can be shown that the timing capacitor-clock period relationship is typically 120  $\mu\text{s/nF}$ . For example, a 10-nF capacitor sets up a clock period of 1.2 ms.

The timing sequence of the LM3881 is controlled by the enable (EN) pin. Upon power up, all the flags are held low until the precision enable pin exceeds its threshold. After the EN pin is asserted, the power-up sequence will commence and the open-drain flags will be sequentially released.

An internal counter will delay the first flag (FLAG1) from rising until a fixed time period, denoted by  $T_{D1}$  in Figure 9, elapses. This corresponds to at least nine, maximum 10, clock cycles depending on where EN is asserted relative to the clock signal. Upon release of the first flag, another timer will begin to delay the release of the second flag (FLAG2). This time delay, denoted  $T_{D2}$ , corresponds to exactly eight clock periods. Similarly, FLAG3 is released after time delay  $T_{D3}$ , again eight clock cycles, has expired. Accordingly, a TADJ capacitor of 10 nF generates typical time delays  $T_{D2}$  and  $T_{D3}$  of 9.6 ms and  $T_{D1}$  of from 10.8 ms to 12.0 ms.

The power-down sequence is the same as power up, but in reverse order. When the EN pin is deasserted, a timer will begin that delays the third flag (FLAG3) from pulling low. The second and first flag will then follow in a sequential manner after their appropriate time delays. These time delays, denoted  $T_{D4}$ ,  $T_{D5}$ ,  $T_{D6}$ , are equal to  $T_{D1}$ ,  $T_{D2}$ ,  $T_{D3}$ , respectively.

For robustness, the pulldown FET associated with each flag is designed such that it can sustain a short circuit to VCC.

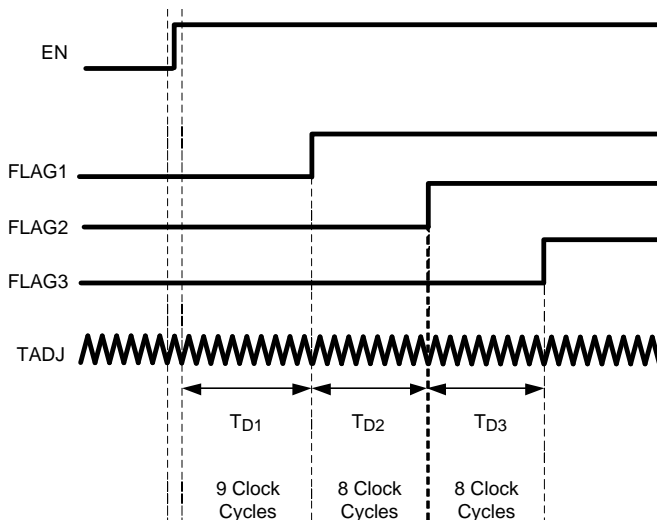
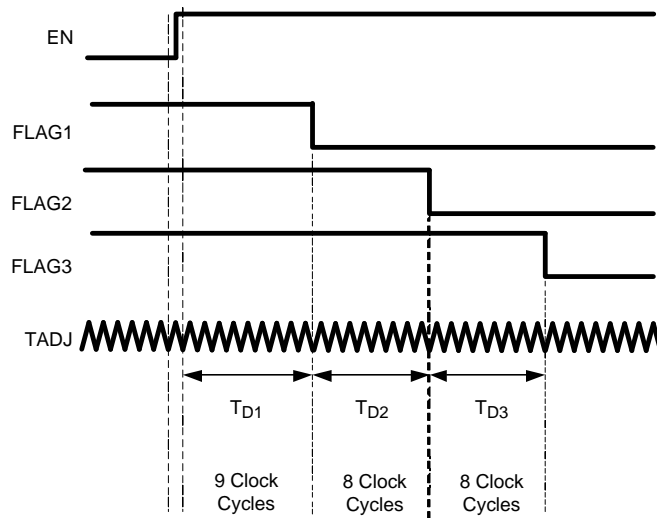
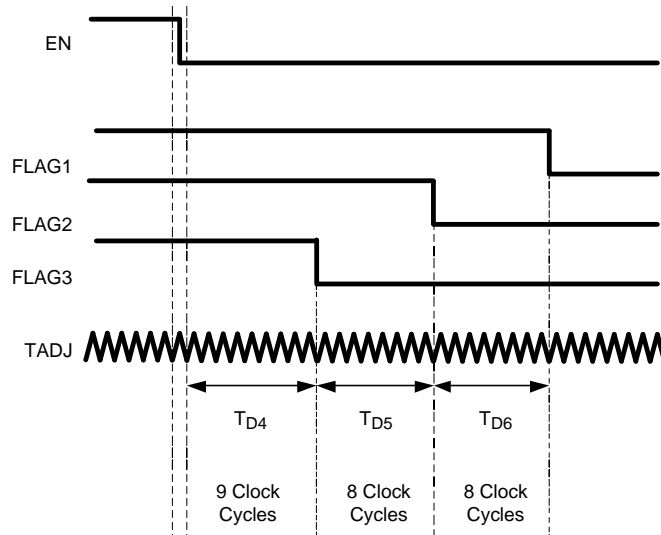

Figure 9. Power-Up Sequence, INV Low

**Feature Description (continued)**

**Figure 10. Power-Up Sequence, INV High**

**Figure 11. Power-Down Sequence, INV Low**

### Feature Description (continued)

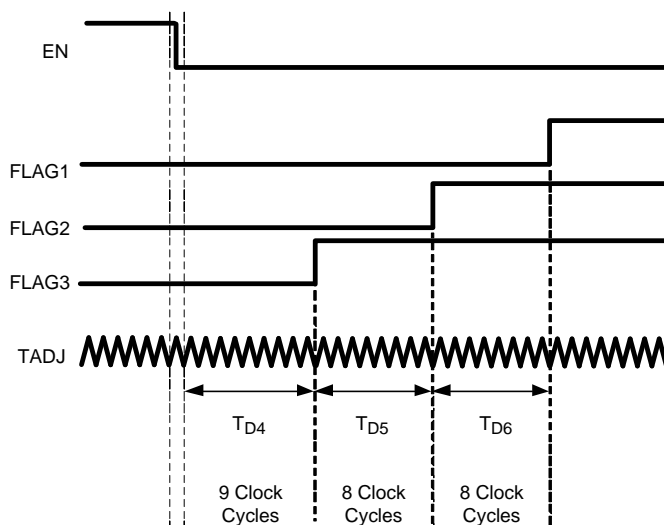

Figure 12. Power-Down Sequence, INV High

#### 7.3.2 Enable Circuit

The enable circuit is designed with an internal comparator, referenced to a bandgap voltage (1.22 V), to provide a precision threshold. This allows the timing to be set externally using a capacitor as shown in Figure 13. Alternatively, sequencing can be based on a certain event such as a line voltage reaching 90% of its nominal value by employing a resistor divider from VCC to Enable.

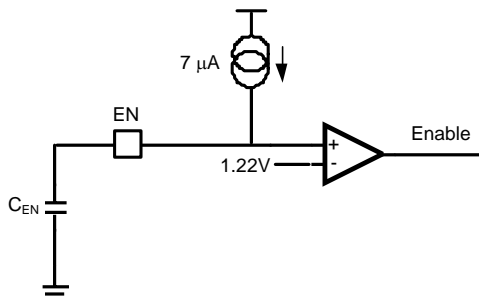

Figure 13. Precision Enable Circuit

Using the internal pullup current source to charge the external capacitor  $C_{EN}$ , the time delay while the enable voltage reaches the required threshold, assuming EN is charging from 0V, can be calculated by the equation as follows.

$$T_{enable\_delay} = \frac{1.22V \times C_{EN}}{7 \mu A} \tag{1}$$

Feature Description (continued)

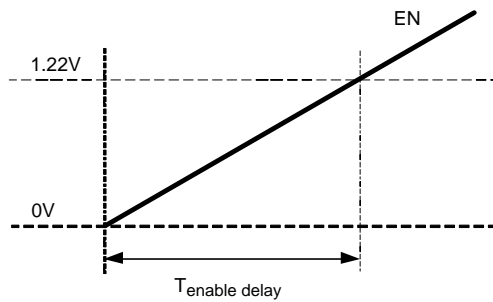

Figure 14. Enable Delay Timing

A resistor divider can also be used to enable the LM3881 based on exceeding a certain VCC supply voltage threshold. Take care when sizing the resistor divider to include the effects of the internal EN pullup current source. The supply voltage for which EN is asserted is given by

$$VCC_{ENABLE} = 1.22V \left( 1 + \frac{R_{EN1}}{R_{EN2}} \right) - 7 \mu A (R_{EN1} || R_{EN2}) \tag{2}$$

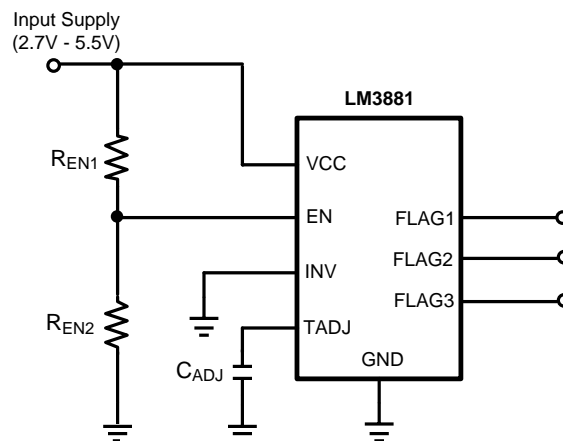

Figure 15. Enable Based On Input Supply Level

One of the features of the EN pin is that it provides glitch free operation. The timer will start counting at a rising threshold, but will always reset if the EN pin is deasserted before the first output flag is released. This is illustrated in Figure 16, assuming INV is low.

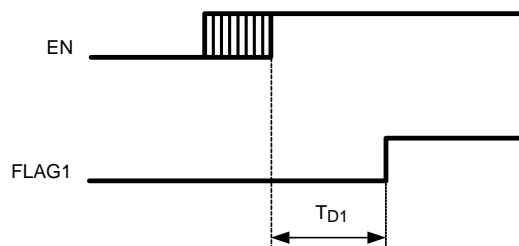

Figure 16. Enable Glitch Timing, INV Low

## Feature Description (continued)

If the EN pin remains high for the entire power up sequence, then the part will operate as shown in the standard timing diagrams. However, if the EN signal is deasserted before the power-up sequence completes, the part will enter a controlled shutdown. This allows the system to initiate a controlled power sequence, preventing any latch conditions to occur. Figure 17 describes the flag sequence if the EN pin is deasserted after FLAG1 releases, but before the entire power-up sequence is completed. INV is assumed low.

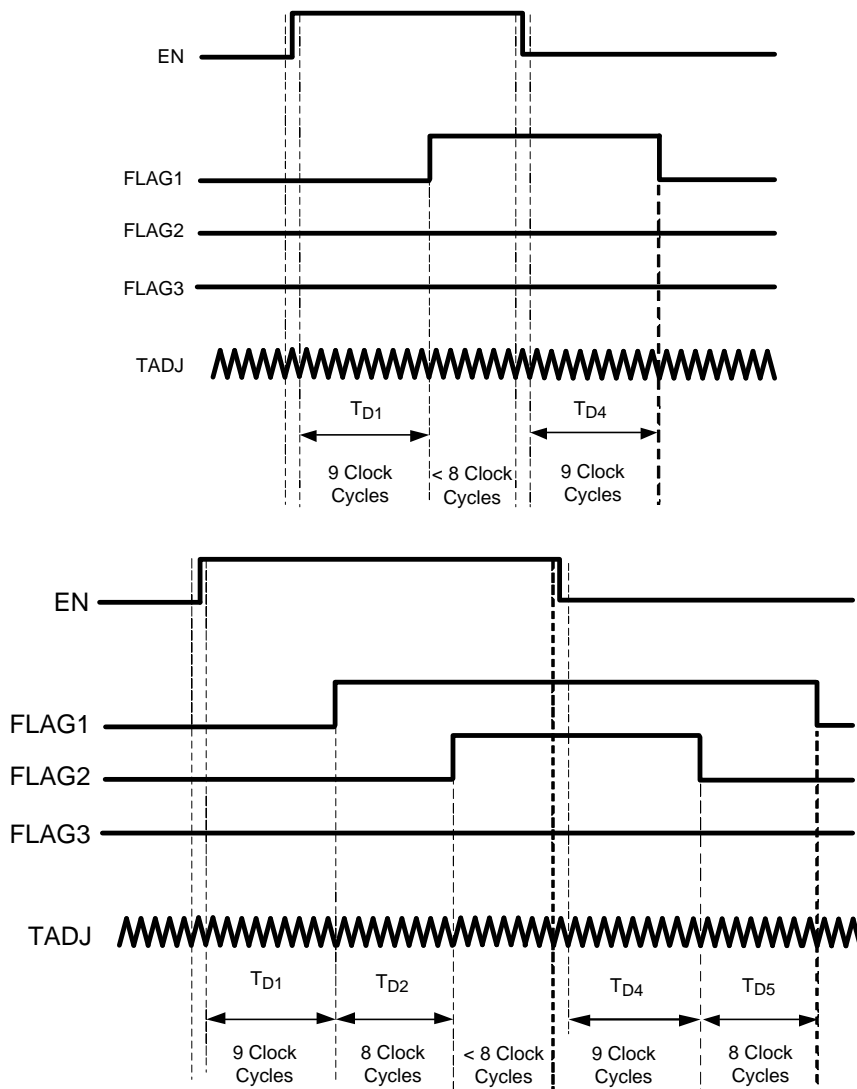

Figure 17. Incomplete Sequence Timing, INV Low

## 7.4 Device Functional Modes

### 7.4.1 Power Up with EN Pin

The timing sequence of the Simple Power Sequencer is controlled entirely by the enable (EN) pin. Upon power up, all the flags are held low until this precision enable is pulled high. After the EN pin is asserted, the power-up sequence will commence.

## Device Functional Modes (continued)

### 7.4.2 Power Down with EN Pin

When EN pin is deasserted, the power down sequence will commence. A timer will begin that delays the third flag (FLAG3) from pulling low. The second and first flag will then follow in a sequential manner after their appropriate delays.

### 7.4.3 Noninverted Output Mode

When the INV pin is tied to a logic output low, the logic mode of the output flags is active high. This mode is useful to sequence power supplies which have an active high enable input.

### 7.4.4 Inverted Output Mode

When the INV pin is tied to a logic output high, the logic mode of the output flags is active low. This mode is useful to sequence power supplies which have an active low enable input.

## 8 Application and Implementation

### NOTE

Information in the following applications sections is not part of the TI component specification, and TI does not warrant its accuracy or completeness. TI's customers are responsible for determining suitability of components for their purposes. Customers should validate and test their design implementation to confirm system functionality.

### 8.1 Application Information

#### 8.1.1 Open-Drain Flags Pullup

The Simple Power Sequencer contains three open-drain output flags which need to be pulled up for proper operation. 100-k $\Omega$  resistors can be used as pullup resistors.

#### 8.1.2 Enable the Device

See [Enable Circuit](#).

#### 8.1.3 Timing Adjust

See [Adjustable Timing](#).

### 8.2 Typical Application

#### 8.2.1 Simple Sequencing of Three Power Supplies

The Simple Power Sequencer is used to implement a power-up (1 - 2 - 3) and power-down (3 - 2 - 1) sequence of three power supplies.

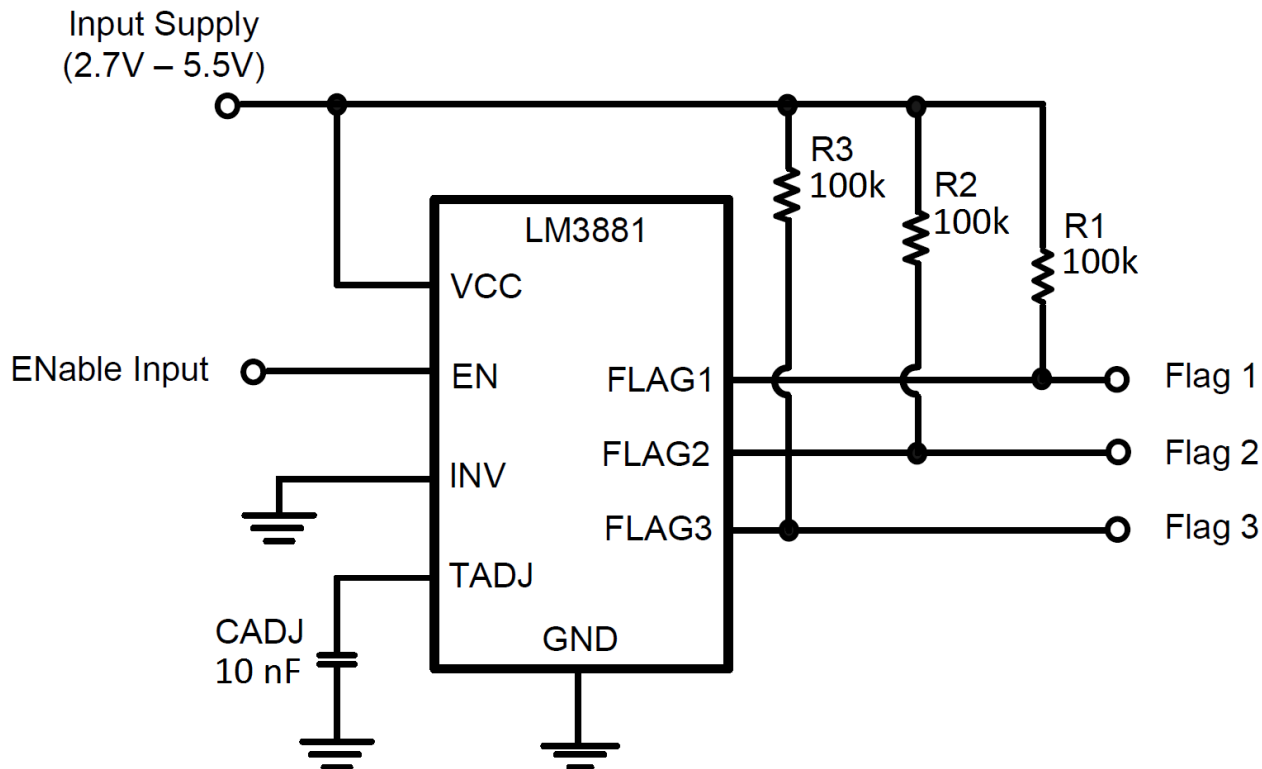

Figure 18. Typical Application Circuit

## Typical Application (continued)

### 8.2.1.1 Design Requirements

For this design example, use the parameters listed in [Table 1](#) as the input parameters.

**Table 1. Design Parameters**

Design Parameter	Example Value
Input Supply voltage range	2.7 V to 5.5 V
Flag Output voltage, EN high	Input Supply
Flag Output voltage, EN low	0 V
Flag Timing Delay, $T_{D1}$	10.8 ms - 12.0 ms
Flag Timing Delay, $T_{D2}$ and $T_{D3}$	9.6 ms
Power-Up Sequence	1 - 2 - 3
Power-Down Sequence	3 - 2 - 1

### 8.2.1.2 Detailed Design Procedure

**Table 2. Evaluation Board Bill of Materials**

Ref Des	Description	Case Size	Manufacturer	Manufacturer P/N
U1	LM3881 Sequencer	MSOP-8	Texas Instruments	LM388
R1	100 k $\Omega$	0603	Vishay Dale	CRCW06031003F-e3
R2	100 k $\Omega$	0603	Vishay Dale	CRCW06031003F-e3
R3	100 k $\Omega$	0603	Vishay Dale	CRCW06031003F-e3
CADJ	10 nF $\pm$ 10% X7R 16 V	0603	Murata	GRM188R71C103KA01

A timing capacitor of  $C_{ADJ} = 10$  nF generates typical time delays  $T_{D2}$  and  $T_{D3}$  of 9.6 ms and  $T_{D1}$  of between 10.8 ms and 12.0 ms. The INV pin is tied to GND so that the output flags are active high. See [Adjustable Timing](#) for calculating the value for  $C_{ADJ}$ .

### 8.2.1.3 Application Curves

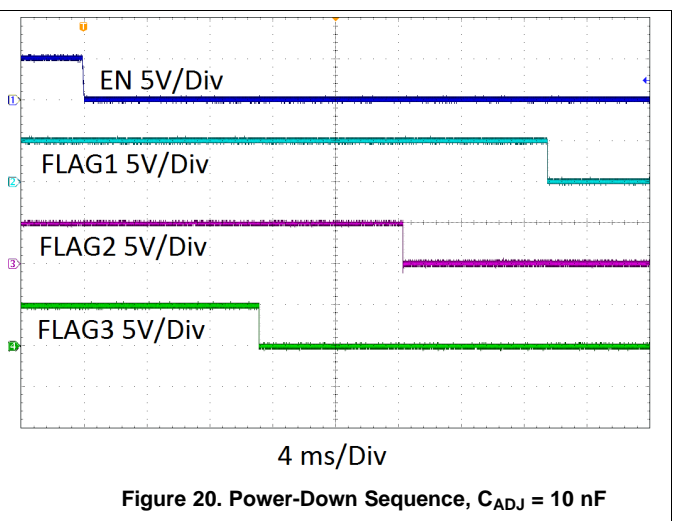
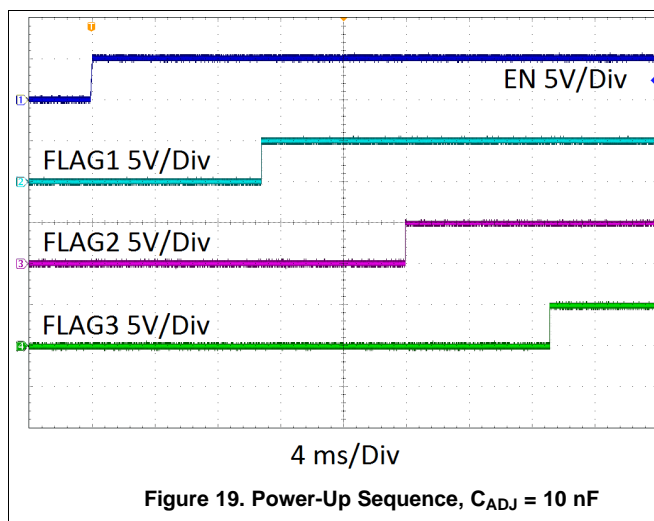

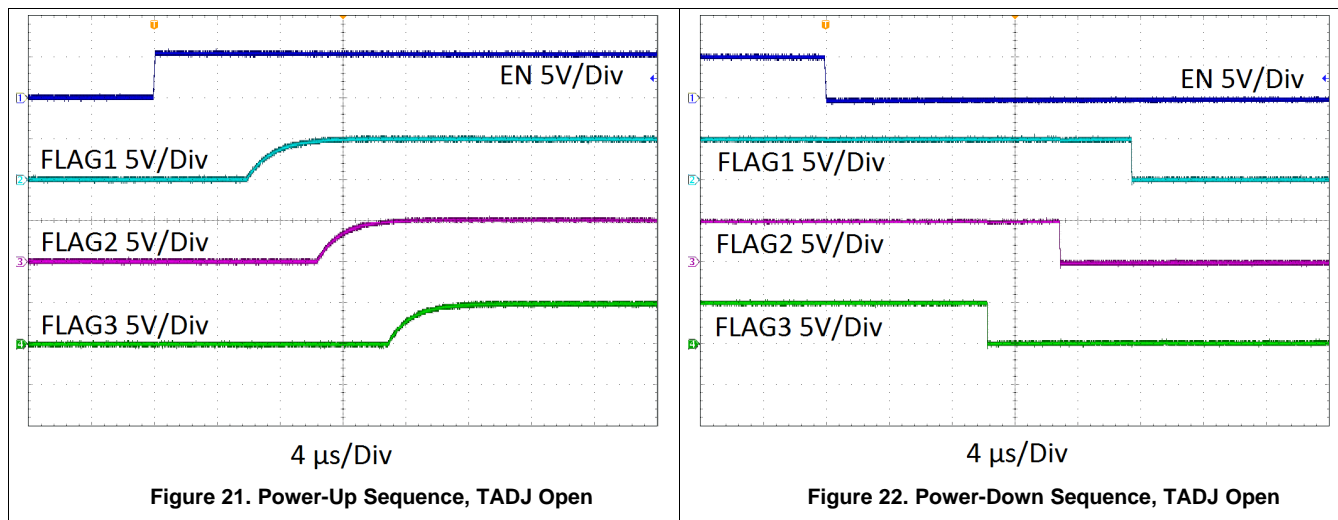

### 8.2.2 Sequencing Using Independent Flag Supply

For applications requiring a flag output voltage that is different from the VCC, a separate Flag Supply may be used to pullup the open-drain outputs of the Simple Power Sequencer. This is useful when interfacing the flag outputs with inputs that require a different voltage than VCC. The designer must ensure the Flag Supply voltage is within the range specified in the [Recommended Operating Conditions](#).

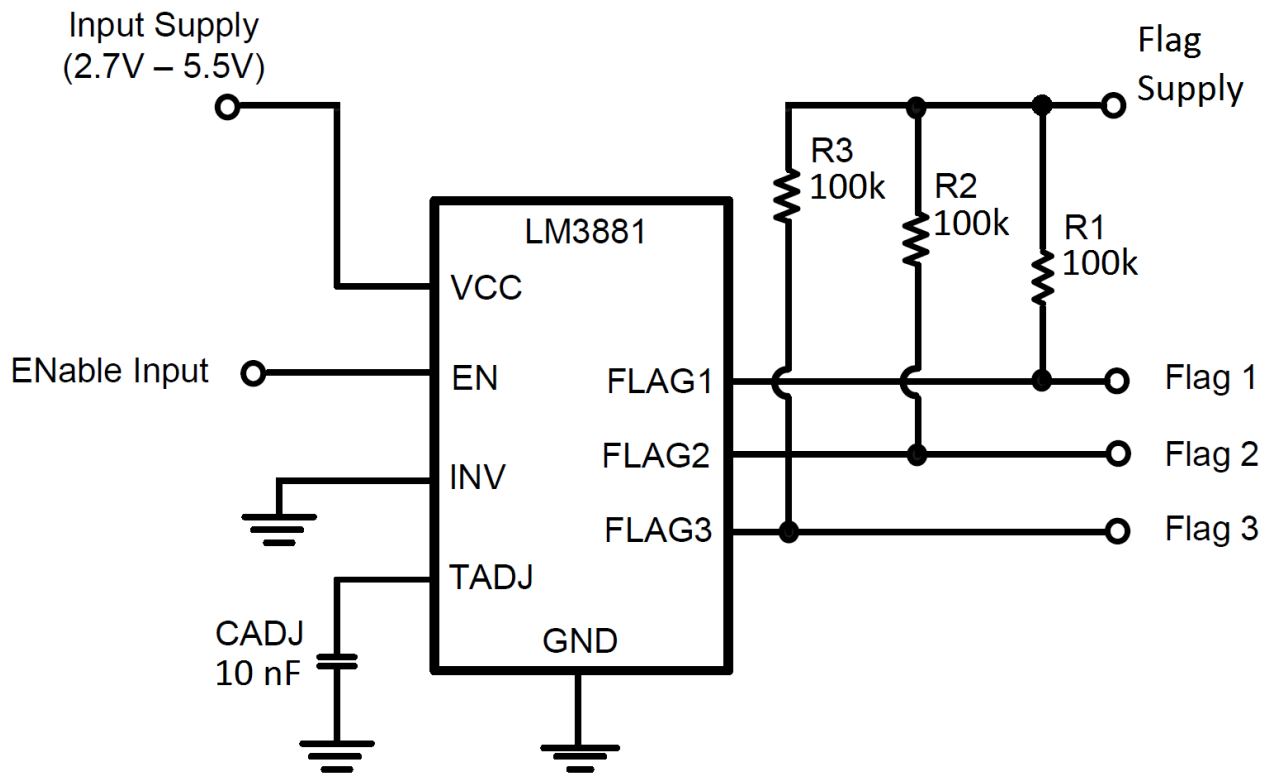

Figure 23. Sequencing Using Independent Flag Supply

## 9 Power Supply Recommendations

The VCC pin should be located as close as possible to the input supply (2.7V - 5.5V). An input capacitor is not required but is recommended when noise might be present on the VCC pin. A 0.1  $\mu\text{F}$  ceramic capacitor may be used to bypass this noise.

## 10 Layout

### 10.1 Layout Guidelines

- Pullup resistors should be connected between the flag output pins and a positive input supply, usually VCC. An independent flag supply may also be used. These resistors should be placed as close as possible to the Simple Power Sequencer and the flag supply. Minimal trace length is recommended to make the connections. A typical value for the pullup resistors is 100k $\Omega$ .
- For very tight sequencing requirements, minimal and equal trace lengths should be used to connect the flag outputs to the desired inputs. This will reduce any propagation delay and timing errors between the flag outputs along the line.

### 10.2 Layout Example

Figure 24 and Figure 25 are layout examples for the LM3881. These examples are taken from the LM3881EVAL. An optional component, assigned reference designator R4, is placed on the bottom side of the PCB to facilitate connection of INV to GND.

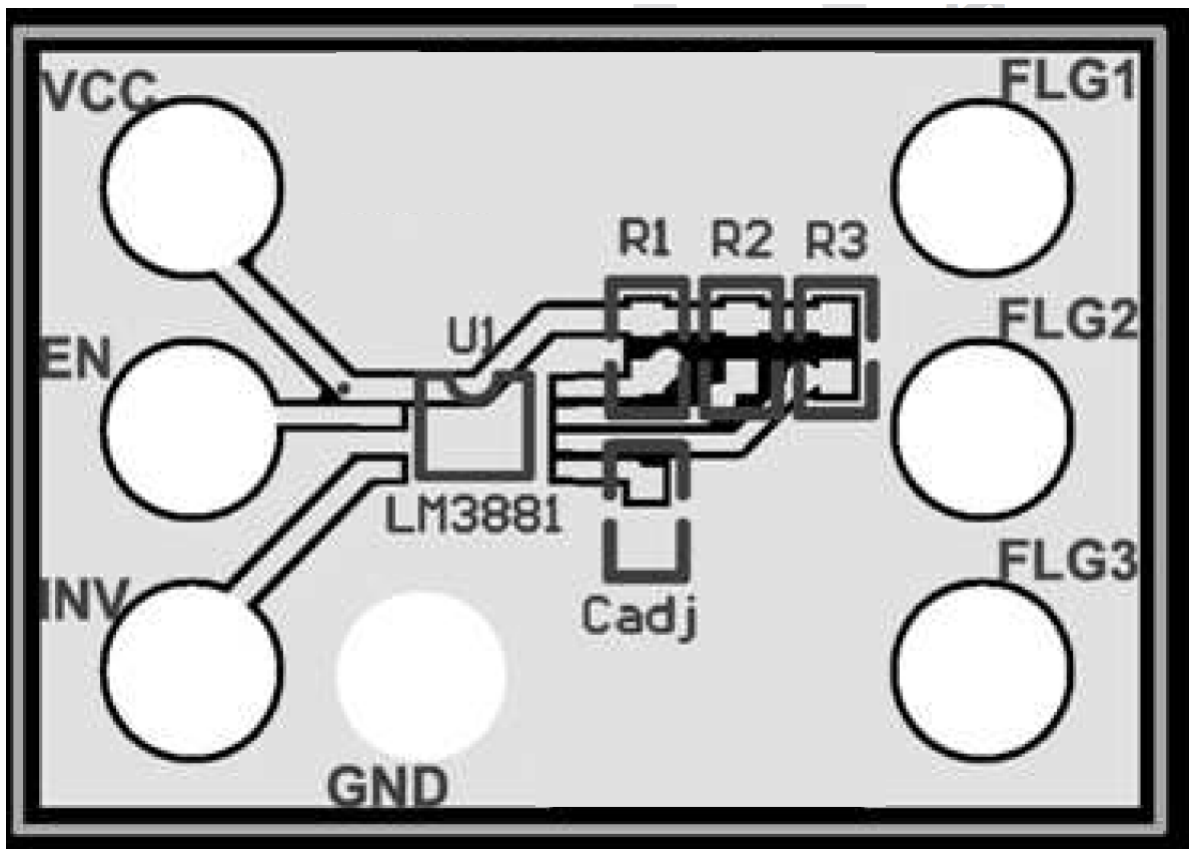

Figure 24. LM3881 Top

Layout Example (continued)

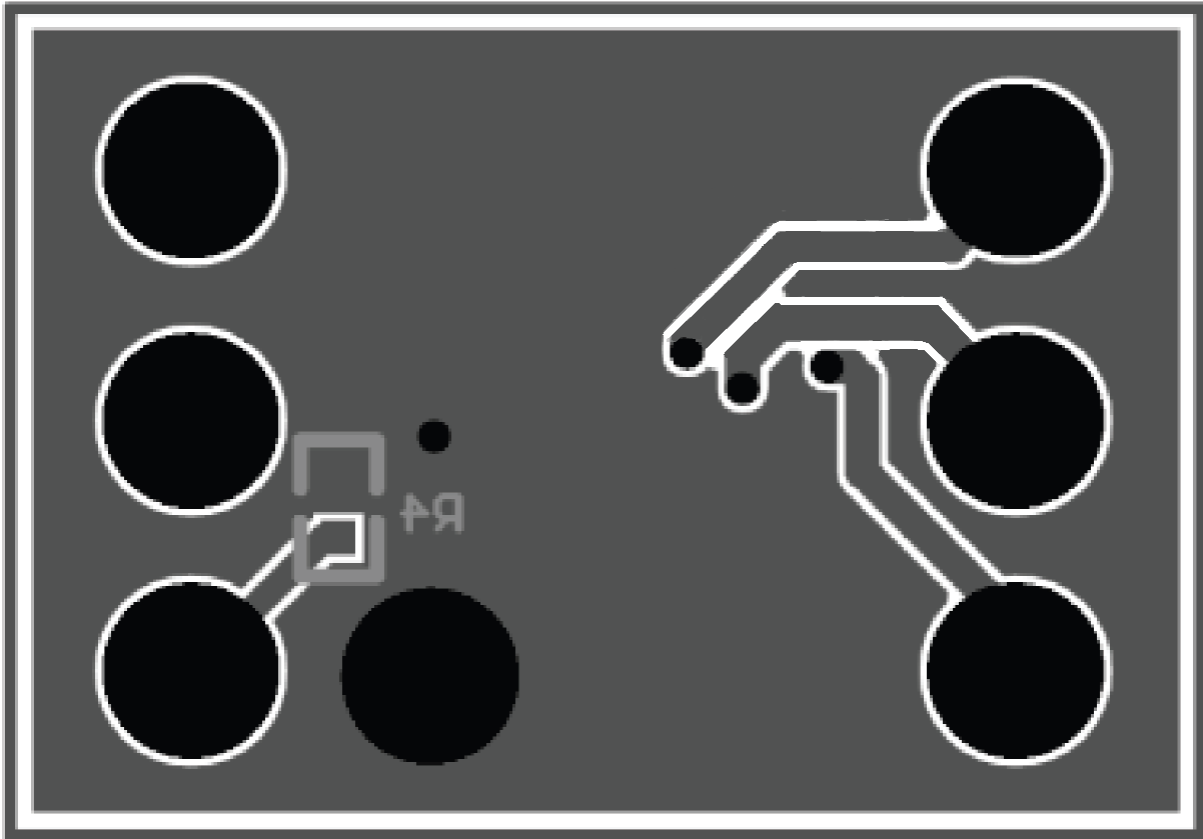

Figure 25. LM3881 Bottom

## 11 Device and Documentation Support

### 11.1 Device Support

#### 11.1.1 Third-Party Products Disclaimer

TI'S PUBLICATION OF INFORMATION REGARDING THIRD-PARTY PRODUCTS OR SERVICES DOES NOT CONSTITUTE AN ENDORSEMENT REGARDING THE SUITABILITY OF SUCH PRODUCTS OR SERVICES OR A WARRANTY, REPRESENTATION OR ENDORSEMENT OF SUCH PRODUCTS OR SERVICES, EITHER ALONE OR IN COMBINATION WITH ANY TI PRODUCT OR SERVICE.

#### 11.2 Trademarks

All trademarks are the property of their respective owners.

#### 11.3 Electrostatic Discharge Caution



These devices have limited built-in ESD protection. The leads should be shorted together or the device placed in conductive foam during storage or handling to prevent electrostatic damage to the MOS gates.

#### 11.4 Glossary

[SLYZ022](#) — *TI Glossary*.

This glossary lists and explains terms, acronyms, and definitions.

## 12 Mechanical, Packaging, and Orderable Information

The following pages include mechanical, packaging, and orderable information. This information is the most current data available for the designated devices. This data is subject to change without notice and revision of this document. For browser-based versions of this data sheet, refer to the left-hand navigation.

**PACKAGING INFORMATION**

Orderable Device	Status (1)	Package Type	Package Drawing	Pins	Package Qty	Eco Plan (2)	Lead/Ball Finish (6)	MSL Peak Temp (3)	Op Temp (°C)	Device Marking (4/5)	Samples
LM3881MM/NOPB	ACTIVE	VSSOP	DGK	8	1000	Green (RoHS & no Sb/Br)	CU SN	Level-1-260C-UNLIM	-40 to 125	STBB	<a href="#">Samples</a>
LM3881MME/NOPB	ACTIVE	VSSOP	DGK	8	250	Green (RoHS & no Sb/Br)	CU SN	Level-1-260C-UNLIM	-40 to 125	STBB	<a href="#">Samples</a>
LM3881MMX/NOPB	ACTIVE	VSSOP	DGK	8	3500	Green (RoHS & no Sb/Br)	CU SN	Level-1-260C-UNLIM	-40 to 125	STBB	<a href="#">Samples</a>

(1) The marketing status values are defined as follows:

**ACTIVE:** Product device recommended for new designs.

**LIFEBUY:** TI has announced that the device will be discontinued, and a lifetime-buy period is in effect.

**NRND:** Not recommended for new designs. Device is in production to support existing customers, but TI does not recommend using this part in a new design.

**PREVIEW:** Device has been announced but is not in production. Samples may or may not be available.

**OBSOLETE:** TI has discontinued the production of the device.

(2) Eco Plan - The planned eco-friendly classification: Pb-Free (RoHS), Pb-Free (RoHS Exempt), or Green (RoHS & no Sb/Br) - please check <http://www.ti.com/productcontent> for the latest availability information and additional product content details.

**TBD:** The Pb-Free/Green conversion plan has not been defined.

**Pb-Free (RoHS):** TI's terms "Lead-Free" or "Pb-Free" mean semiconductor products that are compatible with the current RoHS requirements for all 6 substances, including the requirement that lead not exceed 0.1% by weight in homogeneous materials. Where designed to be soldered at high temperatures, TI Pb-Free products are suitable for use in specified lead-free processes.

**Pb-Free (RoHS Exempt):** This component has a RoHS exemption for either 1) lead-based flip-chip solder bumps used between the die and package, or 2) lead-based die adhesive used between the die and leadframe. The component is otherwise considered Pb-Free (RoHS compatible) as defined above.

**Green (RoHS & no Sb/Br):** TI defines "Green" to mean Pb-Free (RoHS compatible), and free of Bromine (Br) and Antimony (Sb) based flame retardants (Br or Sb do not exceed 0.1% by weight in homogeneous material)

(3) MSL, Peak Temp. - The Moisture Sensitivity Level rating according to the JEDEC industry standard classifications, and peak solder temperature.

(4) There may be additional marking, which relates to the logo, the lot trace code information, or the environmental category on the device.

(5) Multiple Device Markings will be inside parentheses. Only one Device Marking contained in parentheses and separated by a "~" will appear on a device. If a line is indented then it is a continuation of the previous line and the two combined represent the entire Device Marking for that device.

(6) Lead/Ball Finish - Orderable Devices may have multiple material finish options. Finish options are separated by a vertical ruled line. Lead/Ball Finish values may wrap to two lines if the finish value exceeds the maximum column width.

**Important Information and Disclaimer:** The information provided on this page represents TI's knowledge and belief as of the date that it is provided. TI bases its knowledge and belief on information provided by third parties, and makes no representation or warranty as to the accuracy of such information. Efforts are underway to better integrate information from third parties. TI has taken and

continues to take reasonable steps to provide representative and accurate information but may not have conducted destructive testing or chemical analysis on incoming materials and chemicals. TI and TI suppliers consider certain information to be proprietary, and thus CAS numbers and other limited information may not be available for release.

In no event shall TI's liability arising out of such information exceed the total purchase price of the TI part(s) at issue in this document sold by TI to Customer on an annual basis.

## TAPE AND REEL INFORMATION



### QUADRANT ASSIGNMENTS FOR PIN 1 ORIENTATION IN TAPE



\*All dimensions are nominal

Device	Package Type	Package Drawing	Pins	SPQ	Reel Diameter (mm)	Reel Width W1 (mm)	A0 (mm)	B0 (mm)	K0 (mm)	P1 (mm)	W (mm)	Pin1 Quadrant
LM3881MM/NOPB	VSSOP	DGK	8	1000	178.0	12.4	5.3	3.4	1.4	8.0	12.0	Q1
LM3881MME/NOPB	VSSOP	DGK	8	250	178.0	12.4	5.3	3.4	1.4	8.0	12.0	Q1
LM3881MMX/NOPB	VSSOP	DGK	8	3500	330.0	12.4	5.3	3.4	1.4	8.0	12.0	Q1

**TAPE AND REEL BOX DIMENSIONS**

\*All dimensions are nominal

Device	Package Type	Package Drawing	Pins	SPQ	Length (mm)	Width (mm)	Height (mm)
LM3881MM/NOPB	VSSOP	DGK	8	1000	210.0	185.0	35.0
LM3881MME/NOPB	VSSOP	DGK	8	250	210.0	185.0	35.0
LM3881MMX/NOPB	VSSOP	DGK	8	3500	367.0	367.0	35.0

DGK (S-PDSO-G8)

PLASTIC SMALL-OUTLINE PACKAGE

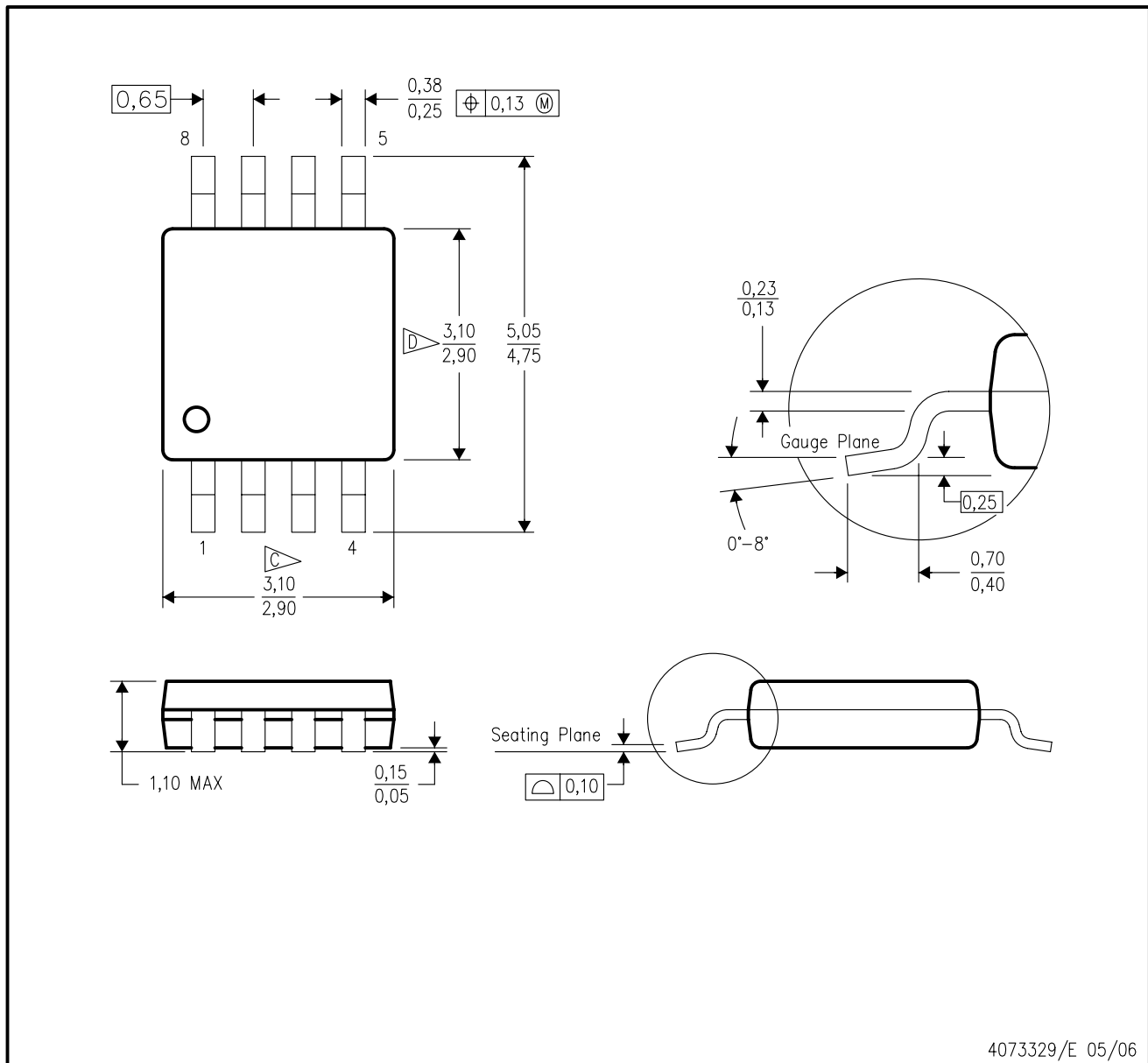

- NOTES:
- A. All linear dimensions are in millimeters.
  - B. This drawing is subject to change without notice.
  - C. Body length does not include mold flash, protrusions, or gate burrs. Mold flash, protrusions, or gate burrs shall not exceed 0.15 per end.
  - D. Body width does not include interlead flash. Interlead flash shall not exceed 0.50 per side.
  - E. Falls within JEDEC MO-187 variation AA, except interlead flash.



- NOTES:
- A. All linear dimensions are in millimeters.
  - B. This drawing is subject to change without notice.
  - C. Publication IPC-7351 is recommended for alternate designs.
  - D. Laser cutting apertures with trapezoidal walls and also rounding corners will offer better paste release. Customers should contact their board assembly site for stencil design recommendations. Refer to IPC-7525 for other stencil recommendations.
  - E. Customers should contact their board fabrication site for solder mask tolerances between and around signal pads.

## IMPORTANT NOTICE AND DISCLAIMER

TI PROVIDES TECHNICAL AND RELIABILITY DATA (INCLUDING DATASHEETS), DESIGN RESOURCES (INCLUDING REFERENCE DESIGNS), APPLICATION OR OTHER DESIGN ADVICE, WEB TOOLS, SAFETY INFORMATION, AND OTHER RESOURCES "AS IS" AND WITH ALL FAULTS, AND DISCLAIMS ALL WARRANTIES, EXPRESS AND IMPLIED, INCLUDING WITHOUT LIMITATION ANY IMPLIED WARRANTIES OF MERCHANTABILITY, FITNESS FOR A PARTICULAR PURPOSE OR NON-INFRINGEMENT OF THIRD PARTY INTELLECTUAL PROPERTY RIGHTS.

These resources are intended for skilled developers designing with TI products. You are solely responsible for (1) selecting the appropriate TI products for your application, (2) designing, validating and testing your application, and (3) ensuring your application meets applicable standards, and any other safety, security, or other requirements. These resources are subject to change without notice. TI grants you permission to use these resources only for development of an application that uses the TI products described in the resource. Other reproduction and display of these resources is prohibited. No license is granted to any other TI intellectual property right or to any third party intellectual property right. TI disclaims responsibility for, and you will fully indemnify TI and its representatives against, any claims, damages, costs, losses, and liabilities arising out of your use of these resources.

TI's products are provided subject to TI's Terms of Sale ([www.ti.com/legal/termsofsale.html](http://www.ti.com/legal/termsofsale.html)) or other applicable terms available either on [ti.com](http://ti.com) or provided in conjunction with such TI products. TI's provision of these resources does not expand or otherwise alter TI's applicable warranties or warranty disclaimers for TI products.

Mailing Address: Texas Instruments, Post Office Box 655303, Dallas, Texas 75265  
Copyright © 2019, Texas Instruments Incorporated

## Looking for pricing, stock, or lifecycle information?

Click below to explore more details on WIN SOURCE:

 [View LM3881MMX/NOPB on WIN SOURCE](#)

 [Texas Instruments](#) Information

## Optimize Your Supply Chain with WIN SOURCE Solutions

-  Global Sourcing Solution
-  Obsolete Management
-  Cost Control Management
-  Shortage Management
-  Alternative Solution
-  Excess Inventory Management