



# THE DATASHEET OF LM386N



# LM386 Low Voltage Audio Power Amplifier

## 1 Features

- Battery Operation
- Minimum External Parts
- Wide Supply Voltage Range: 4 V–12 V or 5 V–18 V
- Low Quiescent Current Drain: 4 mA
- Voltage Gains from 20 to 200
- Ground-Referenced Input
- Self-Centering Output Quiescent Voltage
- Low Distortion: 0.2% ( $A_V = 20$ ,  $V_S = 6$  V,  $R_L = 8$   $\Omega$ ,  $P_O = 125$  mW,  $f = 1$  kHz)
- Available in 8-Pin MSOP Package

## 2 Applications

- AM-FM Radio Amplifiers
- Portable Tape Player Amplifiers
- Intercoms
- TV Sound Systems
- Line Drivers
- Ultrasonic Drivers
- Small Servo Drivers
- Power Converters

## 3 Description

The LM386M-1 and LM386MX-1 are power amplifiers designed for use in low voltage consumer applications. The gain is internally set to 20 to keep external part count low, but the addition of an external resistor and capacitor between pins 1 and 8 increases the gain to any value from 20 to 200.

The inputs are ground referenced while the output automatically biases to one-half the supply voltage. The quiescent power drain is only 24 mW when operating from a 6-V supply, making the LM386M-1 and LM386MX-1 preferred for battery operation.

### Device Information<sup>(1)</sup>

PART NUMBER	PACKAGE	BODY SIZE (NOM)
LM386N-1	PDIP (8)	9.60 mm × 6.35 mm
LM386N-3	PDIP (8)	9.60 mm × 6.35 mm
LM386N-4	PDIP (8)	9.60 mm × 6.35 mm
LM386M-1	SOIC (8)	4.90 mm × 3.90 mm
LM386MX-1	SOIC (8)	4.90 mm × 3.90 mm
LM386MMX-1	VSSOP (8)	3.00 mm × 3.00 mm

(1) For all available packages, see the orderable addendum at the end of the data sheet.

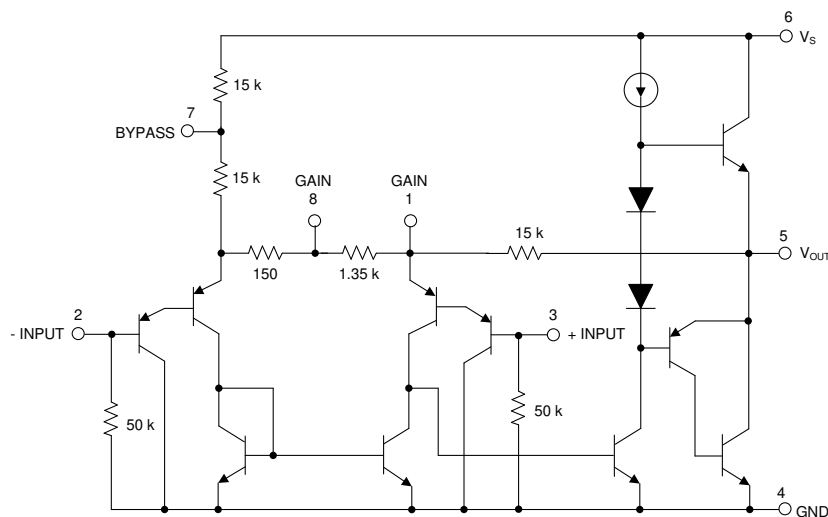

Schematic



## Table of Contents

<b>1 Features</b> .....	1	8.3 Feature Description.....	9
<b>2 Applications</b> .....	1	8.4 Device Functional Modes.....	9
<b>3 Description</b> .....	1	<b>9 Application and Implementation</b> .....	10
<b>4 Revision History</b> .....	2	9.1 Application Information.....	10
<b>5 Pin Configuration and Functions</b> .....	3	9.2 Typical Application.....	10
<b>6 Specifications</b> .....	4	<b>10 Power Supply Recommendations</b> .....	17
6.1 Absolute Maximum Ratings.....	4	<b>11 Layout</b> .....	18
6.2 ESD Ratings.....	4	11.1 Layout Guidelines.....	18
6.3 Recommended Operating Conditions.....	4	11.2 Layout Examples.....	18
6.4 Thermal Information.....	4	<b>12 Device and Documentation Support</b> .....	20
6.5 Electrical Characteristics.....	5	12.1 Device Support.....	20
6.6 Typical Characteristics.....	6	12.2 Documentation Support.....	20
<b>7 Parameter Measurement Information</b> .....	8	12.3 Receiving Notification of Documentation Updates.....	20
<b>8 Detailed Description</b> .....	9	12.4 Community Resources.....	20
8.1 Overview.....	9	12.5 Trademarks.....	20
8.2 Functional Block Diagram.....	9		

## 4 Revision History

NOTE: Page numbers for previous revisions may differ from page numbers in the current version.

<b>Changes from Revision C (May 2017) to Revision D (August 2023)</b>	<b>Page</b>
• Updated Typical Output Power Spec.....	5

<b>Changes from Revision B (March 2017) to Revision C (May 2017)</b>	<b>Page</b>
• Changed devices LM386M-1/LM386MX-1 To: LM386 in the data sheet title.....	1
• Updated the numbering format for tables, figures, and cross-references throughout the document.....	1
• Changed From: LM386N-4 To: Speaker Impedance in the <i>Recommended Operating Conditions</i> table.....	4
• Changed From: 5 Ω to 12 Ω To: 5 V to 12 V for Supply Voltage in <a href="#">Table 9-1</a> .....	10
• Changed kW To: kΩ in the <i>Gain Control</i> section.....	10
• Changed kW To: kΩ in the <i>Input Biasing</i> section.....	11
• Changed <a href="#">Figure 9-2</a> .....	11
• Changed From: 5 Ω to 12 Ω To: 5 V to 12 V for Supply Voltage in <a href="#">Table 9-2</a> .....	12
• Changed <a href="#">Figure 9-4</a> .....	12
• Changed From: 5 Ω to 12 Ω To: 5 V to 12 V for Supply Voltage in <a href="#">Table 9-3</a> .....	13
• Changed <a href="#">Figure 9-6</a> .....	13
• Changed From: 5 Ω to 12 Ω To: 5 V to 12 V for Supply Voltage in <a href="#">Table 9-4</a> .....	14
• Changed <a href="#">Figure 9-8</a> .....	14
• Changed From: 5 Ω to 12 Ω To: 5 V to 12 V for Supply Voltage in <a href="#">Table 9-5</a> .....	15
• Changed From: 5 Ω to 12 Ω To: 5 V to 12 V for Supply Voltage in <a href="#">Table 9-6</a> .....	16
• Changed <a href="#">Figure 9-12</a> .....	16
• Changed From: 5 Ω to 12 Ω To: 5 V to 12 V for Supply Voltage in <a href="#">Table 9-7</a> .....	17
• Changed <a href="#">Figure 9-14</a> .....	17

<b>Changes from Revision A (May 2004) to Revision B (March 2017)</b>	<b>Page</b>
• Added LM386MX-1 device to the data sheet. ....	1
• Added Device Information, Application and Implementation, Power Supply Recommendation, Layout, and Device and Documentation Support sections.....	1
• Inserted Functional Block Diagram.....	9

## 5 Pin Configuration and Functions

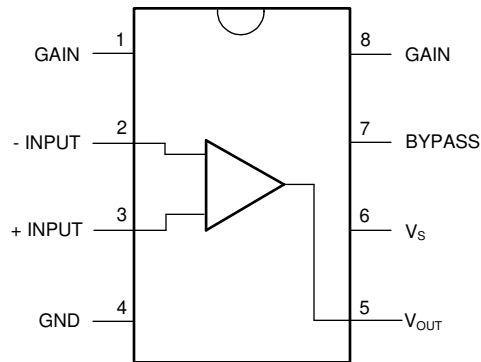

**Figure 5-1. D Package 8-Pin MSOP Top View**

**Table 5-1. Pin Functions**

PIN		TYPE <sup>(1)</sup>	DESCRIPTION
NAME	NO.		
GAIN	1	–	Gain setting pin
–INPUT	2	I	Inverting input
+INPUT	3	I	Noninverting input
GND	4	P	Ground reference
V <sub>OUT</sub>	5	O	Output
V <sub>S</sub>	6	P	Power supply voltage
BYPASS	7	O	Bypass decoupling path
GAIN	8	–	Gain setting pin

(1) I = Input, O = Output, P = Power

## 6 Specifications

### 6.1 Absolute Maximum Ratings

over operating free-air temperature range (unless otherwise noted)<sup>(1)</sup>

		MIN	MAX	UNIT
Supply Voltage, $V_{CC}$	LM386N-1/-3, LM386M-1		15	V
	LM386N-4		22	
Package Dissipation	LM386N		1.25	W
	LM386M		0.73	
	LM386MM-1		0.595	
Input Voltage, $V_I$		-0.4	0.4	V
Storage temperature, $T_{stg}$		-65	150	°C

- (1) Stresses beyond those listed under *Absolute Maximum Ratings* may cause permanent damage to the device. These are stress ratings only, which do not imply functional operation of the device at these or any other conditions beyond those indicated under *Recommended Operating Conditions*. Exposure to absolute-maximum-rated conditions for extended periods may affect device reliability.

### 6.2 ESD Ratings

		VALUE	UNIT
$V_{(ESD)}$ Electrostatic discharge	Human-body model (HBM), per ANSI/ESDA/JEDEC JS-001 <sup>(1)</sup>	±1000	V
	Charged-device model (CDM), per JEDEC specification JESD22-C101 <sup>(2)</sup>	±1000	

- (1) JEDEC document JEP155 states that 500-V HBM allows safe manufacturing with a standard ESD control process.  
 (2) JEDEC document JEP157 states that 250-V CDM allows safe manufacturing with a standard ESD control process.

### 6.3 Recommended Operating Conditions

over operating free-air temperature range (unless otherwise noted)

		MIN	NOM	MAX	UNIT
$V_{CC}$	Supply Voltage	4		12	V
	LM386N-4	5		18	V
	Speaker Impedance	4			Ω
$V_I$	Analog input voltage	-0.4		0.4	V
TA	Operating free-air temperature	0		70	°C

### 6.4 Thermal Information

THERMAL METRIC <sup>(1)</sup>		LM386	LM386	LM386	UNIT
		D (SOIC)	DGK (VSSOP)	P (PDIP)	
		8	8	8	
$R_{\theta JA}$	Junction-to-ambient thermal resistance	115.7	169.3	53.4	°C/W
$R_{\theta JC(top)}$	Junction-to-case (top) thermal resistance	59.7	73.1	42.1	°C/W
$R_{\theta JB}$	Junction-to-board thermal resistance	56.2	100.2	30.6	°C/W
$\psi_{JT}$	Junction-to-top characterization parameter	12.4	9.2	19.0	°C/W
$\psi_{JB}$	Junction-to-board characterization parameter	55.6	99.1	50.5	°C/W

- (1) For more information about traditional and new thermal metrics, see the [Semiconductor and IC Package Thermal Metrics](#) application report.

## 6.5 Electrical Characteristics

over operating free-air temperature range (unless otherwise noted)

PARAMETER		TEST CONDITIONS	MIN	TYP	MAX	UNIT
V <sub>S</sub>	Operating Supply Voltage	LM386N-1, -3, LM386M-1, LM386MM-1	4		12	V
		LM386N-4	5		18	
I <sub>Q</sub>	Quiescent Current	V <sub>S</sub> = 6 V, V <sub>IN</sub> = 0		4	8	mA
P <sub>OUT</sub>	Output Power	V <sub>S</sub> = 6 V, R <sub>L</sub> = 8 Ω, THD = 10% (LM386N-1, LM386M-1, LM386MM-1)	250	325		mW
		V <sub>S</sub> = 9 V, R <sub>L</sub> = 8 Ω, THD = 10% (LM386N-3)	500	700		
		V <sub>S</sub> = 16 V, R <sub>L</sub> = 32 Ω, THD = 10% (LM386N-4)	700	1000		
A <sub>V</sub>	Voltage Gain	V <sub>S</sub> = 6 V, f = 1 kHz		26		dB
		10 μF from Pin 1 to 8		46		
BW	Bandwidth	V <sub>S</sub> = 6 V, Pins 1 and 8 Open		300		kHz
THD	Total Harmonic Distortion	V <sub>S</sub> = 6 V, R <sub>L</sub> = 8 Ω, P <sub>OUT</sub> = 125 mW f = 1 kHz, Pins 1 and 8 Open		0.2%		
PSRR	Power Supply Rejection Ratio	V <sub>S</sub> = 6 V, f = 1 kHz, CBYPASS = 10 μF Pins 1 and 8 Open, Referred to Output		50		dB
R <sub>IN</sub>	Input Resistance			50		kΩ
I <sub>BIAS</sub>	Input Bias Current	V <sub>S</sub> = 6 V, Pins 2 and 3 Open		250		nA

### 6.6 Typical Characteristics

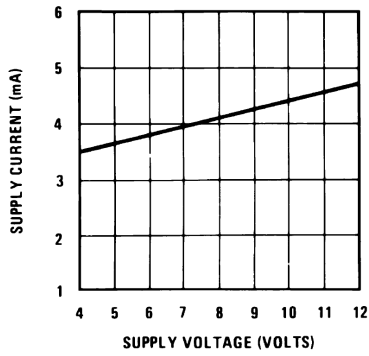

Figure 6-1. Supply Current vs Supply Voltage

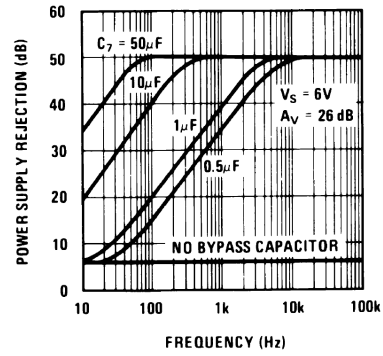

Figure 6-2. Power Supply Rejection vs Frequency

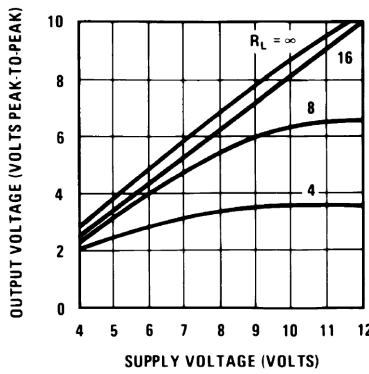

Figure 6-3. Output Voltage vs Supply Voltage

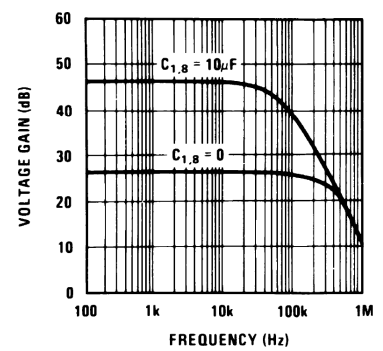

Figure 6-4. Voltage Gain vs Frequency

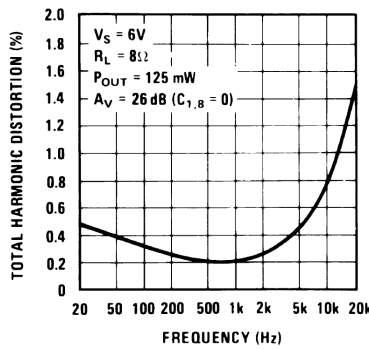

Figure 6-5. Total Harmonic Distortion vs Frequency

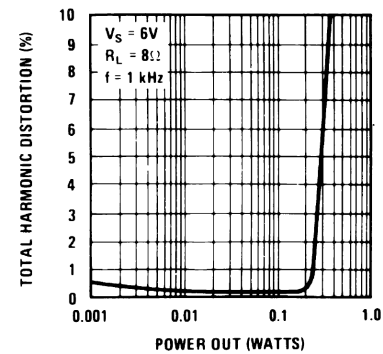

Figure 6-6. Total Harmonic Distortion vs Power Out

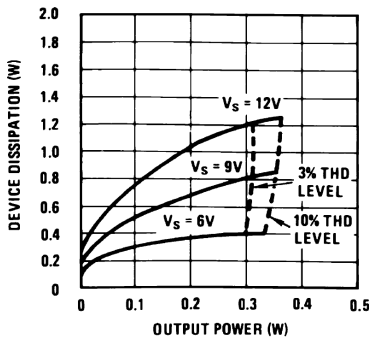

Figure 6-7. Device Dissipation vs Output Power

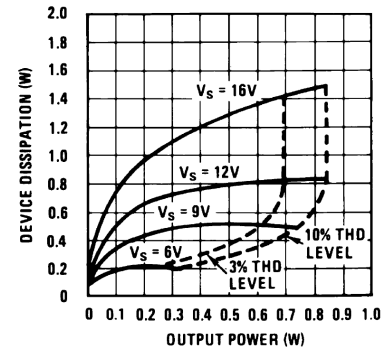
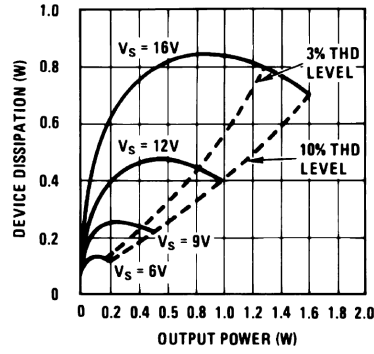

Figure 6-8. Device Dissipation vs Output Power



**Figure 6-9. Device Dissipation vs Output Power**

## 7 Parameter Measurement Information

All parameters are measured according to the conditions described in the [Section 6](#) section.

## 8 Detailed Description

### 8.1 Overview

The LM386 is a mono low voltage amplifier that can be used in a variety of applications. It can drive loads from 4  $\Omega$  to 32  $\Omega$ . The gain is internally set to 20 but it can be modified from 20 to 200 by placing a resistor and capacitor between pins 1 and 8. This device comes in three different 8-pin packages as PDIP, SOIC and VSSOP to fit in different applications.

### 8.2 Functional Block Diagram

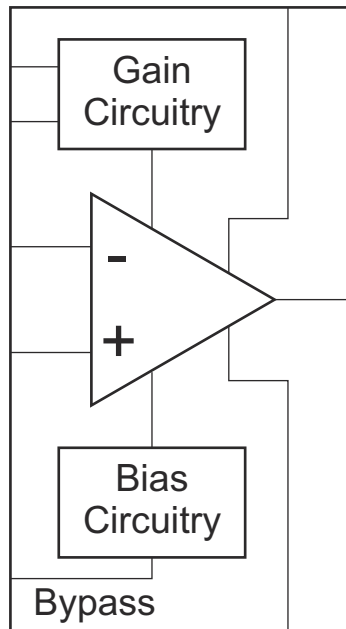

### 8.3 Feature Description

There is an internal 1.35-K $\Omega$  resistor that sets the gain of this device to 20. The gain can be modified from 20 to 200. Detailed information about gain setting can be found in the [Section 9.2.2.2](#) section.

### 8.4 Device Functional Modes

As this is an Op Amp it can be used in different configurations to fit in several applications. The internal gain setting resistor allows the LM386 to be used in a very low part count system. In addition a series resistor can be placed between pins 1 and 5 to modify the gain and frequency response for specific applications.

## 9 Application and Implementation

### Note

Information in the following applications sections is not part of the TI component specification, and TI does not warrant its accuracy or completeness. TI's customers are responsible for determining suitability of components for their purposes. Customers should validate and test their design implementation to confirm system functionality.

### 9.1 Application Information

Below are shown different setups that show how the LM386 can be implemented in a variety of applications.

### 9.2 Typical Application

#### 9.2.1 LM386 with Gain = 20

Figure 9-1 shows the minimum part count application that can be implemented using LM386. Its gain is internally set to 20.

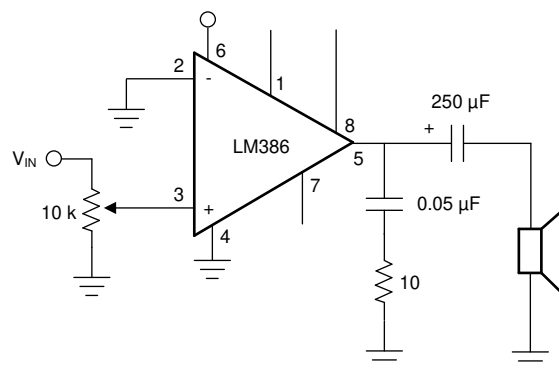

Copyright © 2017, Texas Instruments Incorporated

Figure 9-1. LM386 with Gain = 20

#### 9.2.1.1 Design Requirements

Table 9-1. Design Parameters

DESIGN PARAMETER	EXAMPLE VALUE
Load Impedance	4 Ω to 32 Ω
Supply Voltage	5 V to 12 V

#### 9.2.1.2 Detailed Design Procedure

##### 9.2.1.2.1 Gain Control

To make the LM386 a more versatile amplifier, two pins (1 and 8) are provided for gain control. With pins 1 and 8 open the 1.35-kΩ resistor sets the gain at 20 (26 dB). If a capacitor is put from pin 1 to 8, bypassing the 1.35-kΩ resistor, the gain will go up to 200 (46 dB). If a resistor is placed in series with the capacitor, the gain can be set to any value from 20 to 200. Gain control can also be done by capacitively coupling a resistor (or FET) from pin 1 to ground.

Additional external components can be placed in parallel with the internal feedback resistors to tailor the gain and frequency response for individual applications. For example, we can compensate poor speaker bass response by frequency shaping the feedback path. This is done with a series RC from pin 1 to 5 (paralleling the internal

15-kΩ resistor). For 6 dB effective bass boost:  $R \approx 15 \text{ k}\Omega$ , the lowest value for good stable operation is  $R = 10 \text{ k}\Omega$  if pin 8 is open. If pins 1 and 8 are bypassed then  $R$  as low as 2 kΩ can be used. This restriction is because the amplifier is only compensated for closed-loop gains greater than 9.

### 9.2.1.2.2 Input Biasing

The schematic shows that both inputs are biased to ground with a 50 kΩ resistor. The base current of the input transistors is about 250 nA, so the inputs are at about 12.5 mV when left open. If the dc source resistance driving the LM386 is higher than 250 kΩ it will contribute very little additional offset (about 2.5 mV at the input, 50 mV at the output). If the dc source resistance is less than 10 kΩ, then shorting the unused input to ground will keep the offset low (about 2.5 mV at the input, 50 mV at the output). For dc source resistances between these values we can eliminate excess offset by putting a resistor from the unused input to ground, equal in value to the dc source resistance. Of course all offset problems are eliminated if the input is capacitively coupled.

When using the LM386 with higher gains (bypassing the 1.35 kΩ resistor between pins 1 and 8) it is necessary to bypass the unused input, preventing degradation of gain and possible instabilities. This is done with a 0.1 μF capacitor or a short to ground depending on the dc source resistance on the driven input.

### 9.2.1.3 Application Curve

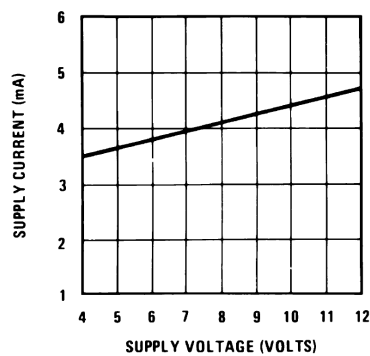

**Figure 9-2. Supply Current vs Supply Voltage**

### 9.2.2 LM386 with Gain = 200

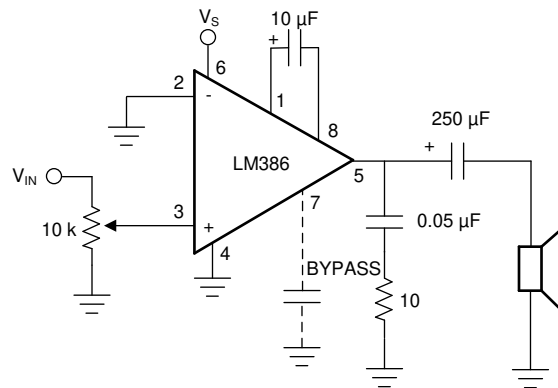

Copyright © 2017, Texas Instruments Incorporated

Figure 9-3. LM386 with Gain = 200

#### 9.2.2.1 Design Requirements

Table 9-2. Design Parameters

DESIGN PARAMETER	EXAMPLE VALUE
Load Impedance	4 Ω to 32 Ω
Supply Voltage	5 V to 12 V

#### 9.2.2.2 Detailed Design Procedure

The Detailed Design Procedure can be found in the [Section 9.2.1.2](#) section.

#### 9.2.2.3 Application Curve

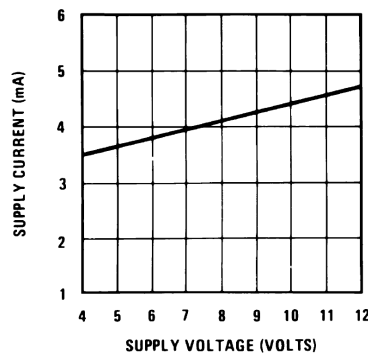
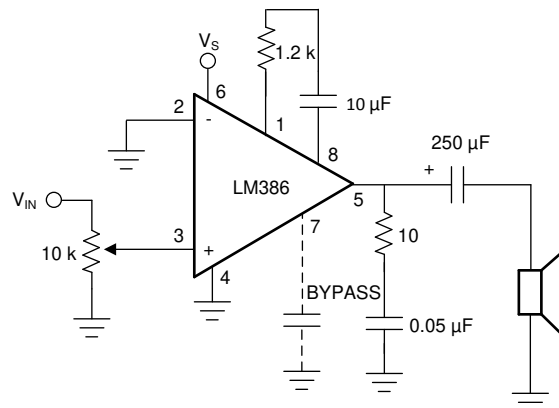

Figure 9-4. Supply Current vs Supply Voltage

### 9.2.3 LM386 with Gain = 50



Copyright © 2017, Texas Instruments Incorporated

Figure 9-5. LM386 with Gain = 50

#### 9.2.3.1 Design Requirements

Table 9-3. Design Parameters

DESIGN PARAMETER	EXAMPLE VALUE
Load Impedance	4 Ω to 32 Ω
Supply Voltage	5 V to 12 V

#### 9.2.3.2 Detailed Design Procedure

The Detailed Design Procedure can be found in the [Section 9.2.1.2](#) section.

#### 9.2.3.3 Application Curve

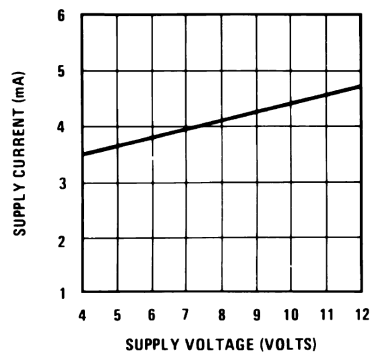
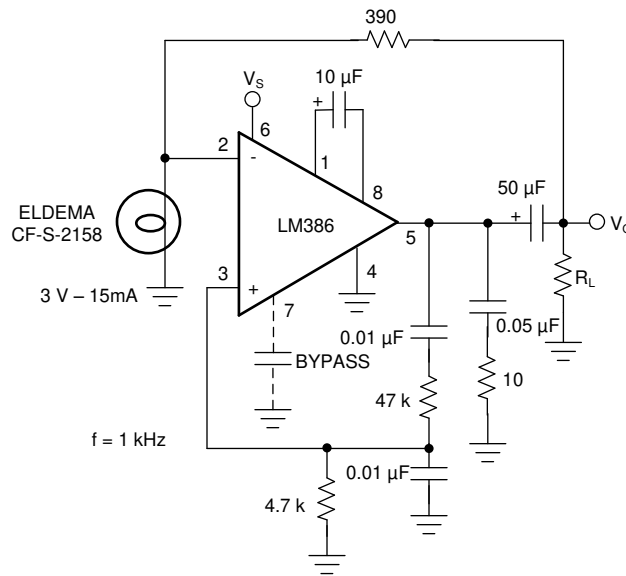

Figure 9-6. Supply Current vs Supply Voltage

### 9.2.4 Low Distortion Power Wienbridge Oscillator



Copyright © 2017, Texas Instruments Incorporated

Figure 9-7. Low Distortion Power Wienbridge Oscillator

#### 9.2.4.1 Design Requirements

Table 9-4. Design Parameters

DESIGN PARAMETER	EXAMPLE VALUE
Load Impedance	4 Ω to 32 Ω
Supply Voltage	5 V to 12 V

#### 9.2.4.2 Detailed Design Procedure

The Detailed Design Procedure can be found in the [Section 9.2.1.2](#) section.

#### 9.2.4.3 Application Curve

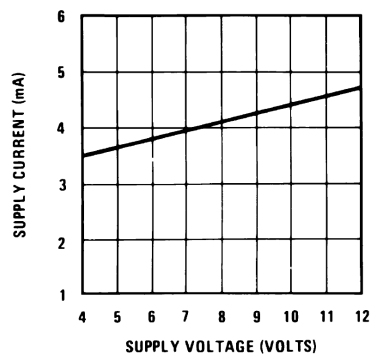
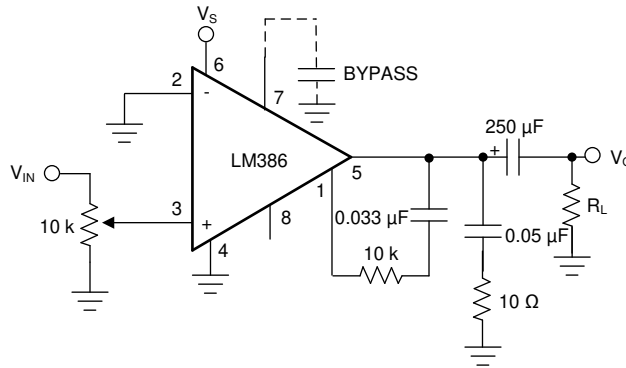

Figure 9-8. Supply Current vs Supply Voltage

### 9.2.5 LM386 with Bass Boost



Copyright © 2017, Texas Instruments Incorporated

**Figure 9-9. LM386 with Bass Boost**

#### 9.2.5.1 Design Requirements

**Table 9-5. Design Parameters**

DESIGN PARAMETER	EXAMPLE VALUE
Load Impedance	4 Ω to 32 Ω
Supply Voltage	5 V to 12 V

#### 9.2.5.2 Detailed Design Procedure

The Detailed Design Procedure can be found in the [Section 9.2.1.2](#) section.

#### 9.2.5.3 Application Curve

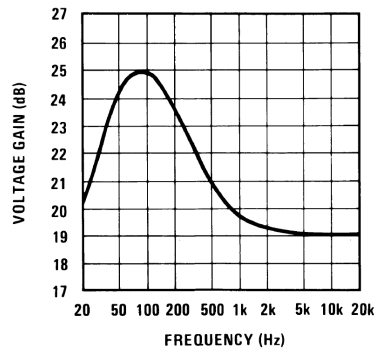

**Figure 9-10. Voltage Gain vs Frequency**

### 9.2.6 Square Wave Oscillator

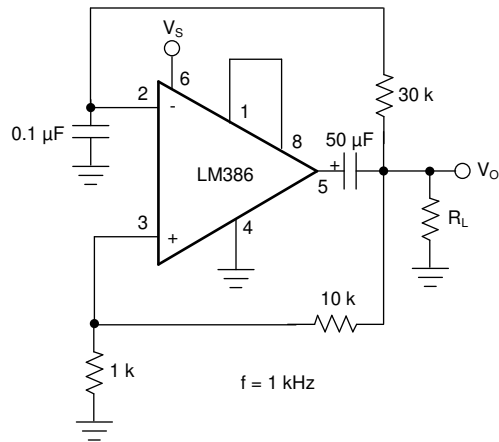

Copyright © 2017, Texas Instruments Incorporated

Figure 9-11. Square Wave Oscillator

Table 9-6. Design Parameters

DESIGN PARAMETER	EXAMPLE VALUE
Load Impedance	4 Ω to 32 Ω
Supply Voltage	5 V to 12 V

#### 9.2.6.1 Detailed Design Procedure

The Detailed Design Procedure can be found in the [Section 9.2.1.2](#) section.

#### 9.2.6.2 Application Curve

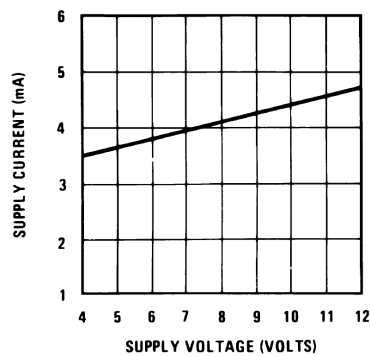
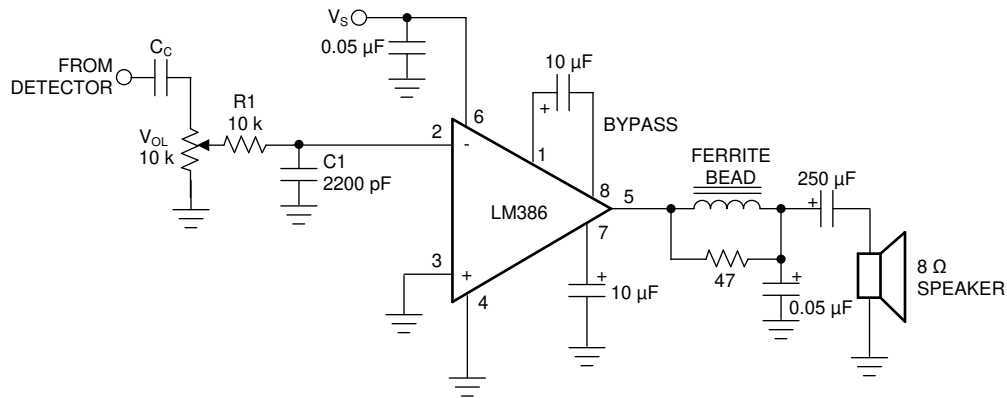

Figure 9-12. Supply Current vs Supply Voltage

### 9.2.7 AM Radio Power Amplifier



Copyright © 2017, Texas Instruments Incorporated

Figure 9-13. AM Radio Power Amplifier

#### 9.2.7.1 Design Requirements

Table 9-7. Design Parameters

DESIGN PARAMETER	EXAMPLE VALUE
Load Impedance	4 Ω to 32 Ω
Supply Voltage	5 V to 12 V

#### 9.2.7.2 Detailed Design Procedure

The Detailed Design Procedure can be found in the [Section 9.2.1.2](#) section.

#### 9.2.7.3 Application Curve

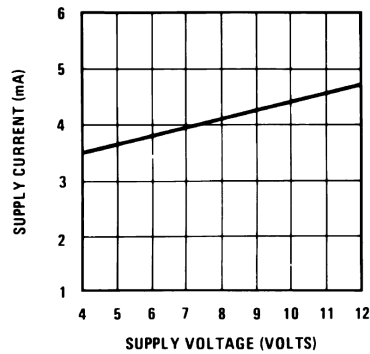

Figure 9-14. Supply Current vs Supply Voltage

## 10 Power Supply Recommendations

The LM386 is specified for operation up to 12 V or 18 V. The power supply should be well regulated and the voltage must be within the specified values. It is recommended to place a capacitor to GND close to the LM386 power supply pin.

## 11 Layout

### 11.1 Layout Guidelines

Place all required components as close as possible to the device. Use short traces for the output to the speaker connection. Route the analog traces far from the digital signal traces and avoid crossing them.

### 11.2 Layout Examples

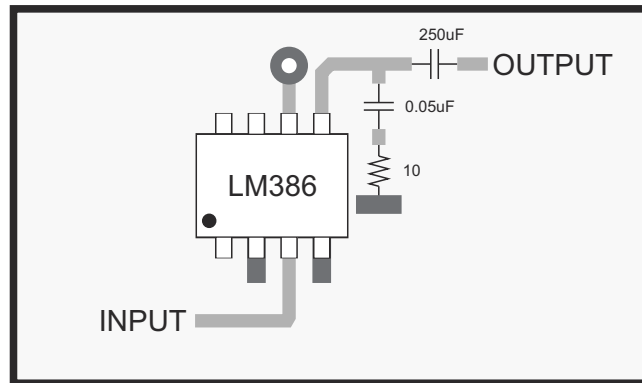

**Figure 11-1. Layout Example for Minimum Parts Gain = 20 dB on PDIP package**

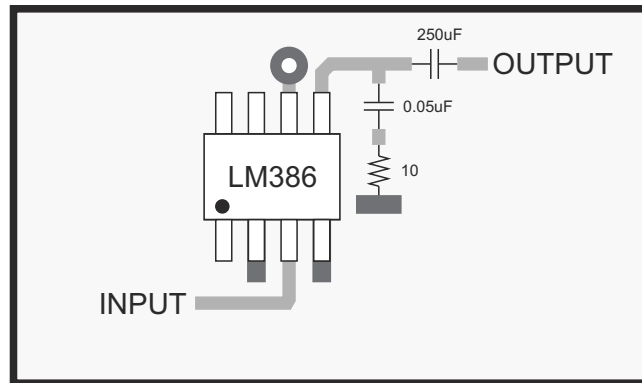

**Figure 11-2. Layout Example for Minimum Parts Gain = 20 dB on SOIC package**

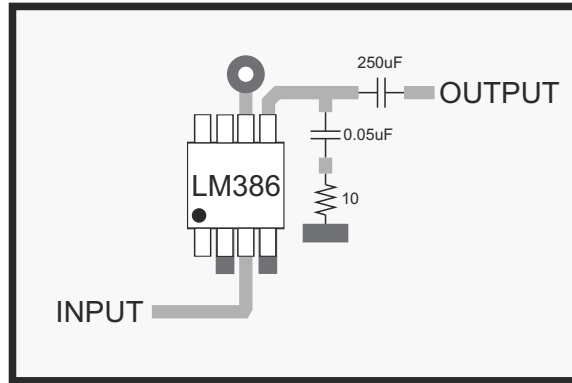

-  Connection to ground plane
-  Connection to power 5V
-  Top layer traces
-  Top layer ground plane

**Figure 11-3. Layout Example for Minimum Parts Gain = 20 dB on VSSOP package**

## 12 Device and Documentation Support

### 12.1 Device Support

#### 12.1.1 Development Support

### 12.2 Documentation Support

### 12.3 Receiving Notification of Documentation Updates

To receive notification of documentation updates — go to the product folder for your device on ti.com. In the upper right-hand corner, click the *Alert me* button to register and receive a weekly digest of product information that has changed (if any). For change details, check the revision history of any revised document.

### 12.4 Community Resources

### 12.5 Trademarks

All trademarks are the property of their respective owners.

## Mechanical, Packaging, and Orderable Information

The following pages include mechanical, packaging, and orderable information. This information is the most current data available for the designated devices. This data is subject to change without notice and revision of this document. For browser-based versions of this data sheet, refer to the left-hand navigation.

**PACKAGING INFORMATION**

Orderable Device	Status (1)	Package Type	Package Drawing	Pins	Package Qty	Eco Plan (2)	Lead finish/ Ball material (6)	MSL Peak Temp (3)	Op Temp (°C)	Device Marking (4/5)	Samples
LM386M-1/NOPB	ACTIVE	SOIC	D	8	95	RoHS & Green	SN	Level-1-260C-UNLIM	0 to 70	LM386 M-1	<a href="#">Samples</a>
LM386MMX-1/NOPB	ACTIVE	VSSOP	DGK	8	3500	RoHS & Green	SN	Level-1-260C-UNLIM	0 to 70	Z86	<a href="#">Samples</a>
LM386MX-1/NOPB	ACTIVE	SOIC	D	8	2500	RoHS & Green	SN	Level-1-260C-UNLIM	0 to 70	LM386 M-1	<a href="#">Samples</a>
LM386N-1/NOPB	ACTIVE	PDIP	P	8	40	RoHS & Green	NIPDAU	Level-1-NA-UNLIM	0 to 70	LM 386N-1	<a href="#">Samples</a>
LM386N-3/NOPB	ACTIVE	PDIP	P	8	40	RoHS & Green	NIPDAU	Level-1-NA-UNLIM	0 to 70	LM 386N-3	<a href="#">Samples</a>
LM386N-4/NOPB	ACTIVE	PDIP	P	8	40	RoHS & Green	NIPDAU	Level-1-NA-UNLIM	0 to 70	LM 386N-4	<a href="#">Samples</a>

(1) The marketing status values are defined as follows:

**ACTIVE:** Product device recommended for new designs.

**LIFEBUY:** TI has announced that the device will be discontinued, and a lifetime-buy period is in effect.

**NRND:** Not recommended for new designs. Device is in production to support existing customers, but TI does not recommend using this part in a new design.

**PREVIEW:** Device has been announced but is not in production. Samples may or may not be available.

**OBSELETE:** TI has discontinued the production of the device.

(2) **RoHS:** TI defines "RoHS" to mean semiconductor products that are compliant with the current EU RoHS requirements for all 10 RoHS substances, including the requirement that RoHS substance do not exceed 0.1% by weight in homogeneous materials. Where designed to be soldered at high temperatures, "RoHS" products are suitable for use in specified lead-free processes. TI may reference these types of products as "Pb-Free".

**RoHS Exempt:** TI defines "RoHS Exempt" to mean products that contain lead but are compliant with EU RoHS pursuant to a specific EU RoHS exemption.

**Green:** TI defines "Green" to mean the content of Chlorine (Cl) and Bromine (Br) based flame retardants meet JS709B low halogen requirements of <=1000ppm threshold. Antimony trioxide based flame retardants must also meet the <=1000ppm threshold requirement.

(3) MSL, Peak Temp. - The Moisture Sensitivity Level rating according to the JEDEC industry standard classifications, and peak solder temperature.

(4) There may be additional marking, which relates to the logo, the lot trace code information, or the environmental category on the device.

(5) Multiple Device Markings will be inside parentheses. Only one Device Marking contained in parentheses and separated by a "~" will appear on a device. If a line is indented then it is a continuation of the previous line and the two combined represent the entire Device Marking for that device.

<sup>(6)</sup> Lead finish/Ball material - Orderable Devices may have multiple material finish options. Finish options are separated by a vertical ruled line. Lead finish/Ball material values may wrap to two lines if the finish value exceeds the maximum column width.

**Important Information and Disclaimer:**The information provided on this page represents TI's knowledge and belief as of the date that it is provided. TI bases its knowledge and belief on information provided by third parties, and makes no representation or warranty as to the accuracy of such information. Efforts are underway to better integrate information from third parties. TI has taken and continues to take reasonable steps to provide representative and accurate information but may not have conducted destructive testing or chemical analysis on incoming materials and chemicals. TI and TI suppliers consider certain information to be proprietary, and thus CAS numbers and other limited information may not be available for release.

In no event shall TI's liability arising out of such information exceed the total purchase price of the TI part(s) at issue in this document sold by TI to Customer on an annual basis.

**TAPE AND REEL INFORMATION**

**QUADRANT ASSIGNMENTS FOR PIN 1 ORIENTATION IN TAPE**

\*All dimensions are nominal

Device	Package Type	Package Drawing	Pins	SPQ	Reel Diameter (mm)	Reel Width W1 (mm)	A0 (mm)	B0 (mm)	K0 (mm)	P1 (mm)	W (mm)	Pin1 Quadrant
LM386MMX-1/NOPB	VSSOP	DGK	8	3500	330.0	12.4	5.3	3.4	1.4	8.0	12.0	Q1
LM386MX-1/NOPB	SOIC	D	8	2500	330.0	12.4	6.5	5.4	2.0	8.0	12.0	Q1

## TAPE AND REEL BOX DIMENSIONS



\*All dimensions are nominal

Device	Package Type	Package Drawing	Pins	SPQ	Length (mm)	Width (mm)	Height (mm)
LM386MMX-1/NOPB	VSSOP	DGK	8	3500	367.0	367.0	35.0
LM386MX-1/NOPB	SOIC	D	8	2500	367.0	367.0	35.0

**TUBE**

\*All dimensions are nominal

Device	Package Name	Package Type	Pins	SPQ	L (mm)	W (mm)	T (μm)	B (mm)
LM386M-1/NOPB	D	SOIC	8	95	495	8	4064	3.05
LM386N-1/NOPB	P	PDIP	8	40	502	14	11938	4.32
LM386N-3/NOPB	P	PDIP	8	40	502	14	11938	4.32
LM386N-4/NOPB	P	PDIP	8	40	502	14	11938	4.32



D0008A

# PACKAGE OUTLINE

SOIC - 1.75 mm max height

SMALL OUTLINE INTEGRATED CIRCUIT



4214825/C 02/2019

### NOTES:

1. Linear dimensions are in inches [millimeters]. Dimensions in parenthesis are for reference only. Controlling dimensions are in inches. Dimensioning and tolerancing per ASME Y14.5M.
2. This drawing is subject to change without notice.
3. This dimension does not include mold flash, protrusions, or gate burrs. Mold flash, protrusions, or gate burrs shall not exceed  $.006$  [0.15] per side.
4. This dimension does not include interlead flash.
5. Reference JEDEC registration MS-012, variation AA.

# EXAMPLE BOARD LAYOUT

D0008A

SOIC - 1.75 mm max height

SMALL OUTLINE INTEGRATED CIRCUIT



LAND PATTERN EXAMPLE  
EXPOSED METAL SHOWN  
SCALE:8X



SOLDER MASK DETAILS

4214825/C 02/2019

NOTES: (continued)

- 6. Publication IPC-7351 may have alternate designs.
- 7. Solder mask tolerances between and around signal pads can vary based on board fabrication site.

# EXAMPLE STENCIL DESIGN

D0008A

SOIC - 1.75 mm max height

SMALL OUTLINE INTEGRATED CIRCUIT



SOLDER PASTE EXAMPLE  
BASED ON .005 INCH [0.125 MM] THICK STENCIL  
SCALE:8X

4214825/C 02/2019

NOTES: (continued)

8. Laser cutting apertures with trapezoidal walls and rounded corners may offer better paste release. IPC-7525 may have alternate design recommendations.
9. Board assembly site may have different recommendations for stencil design.

P (R-PDIP-T8)

PLASTIC DUAL-IN-LINE PACKAGE

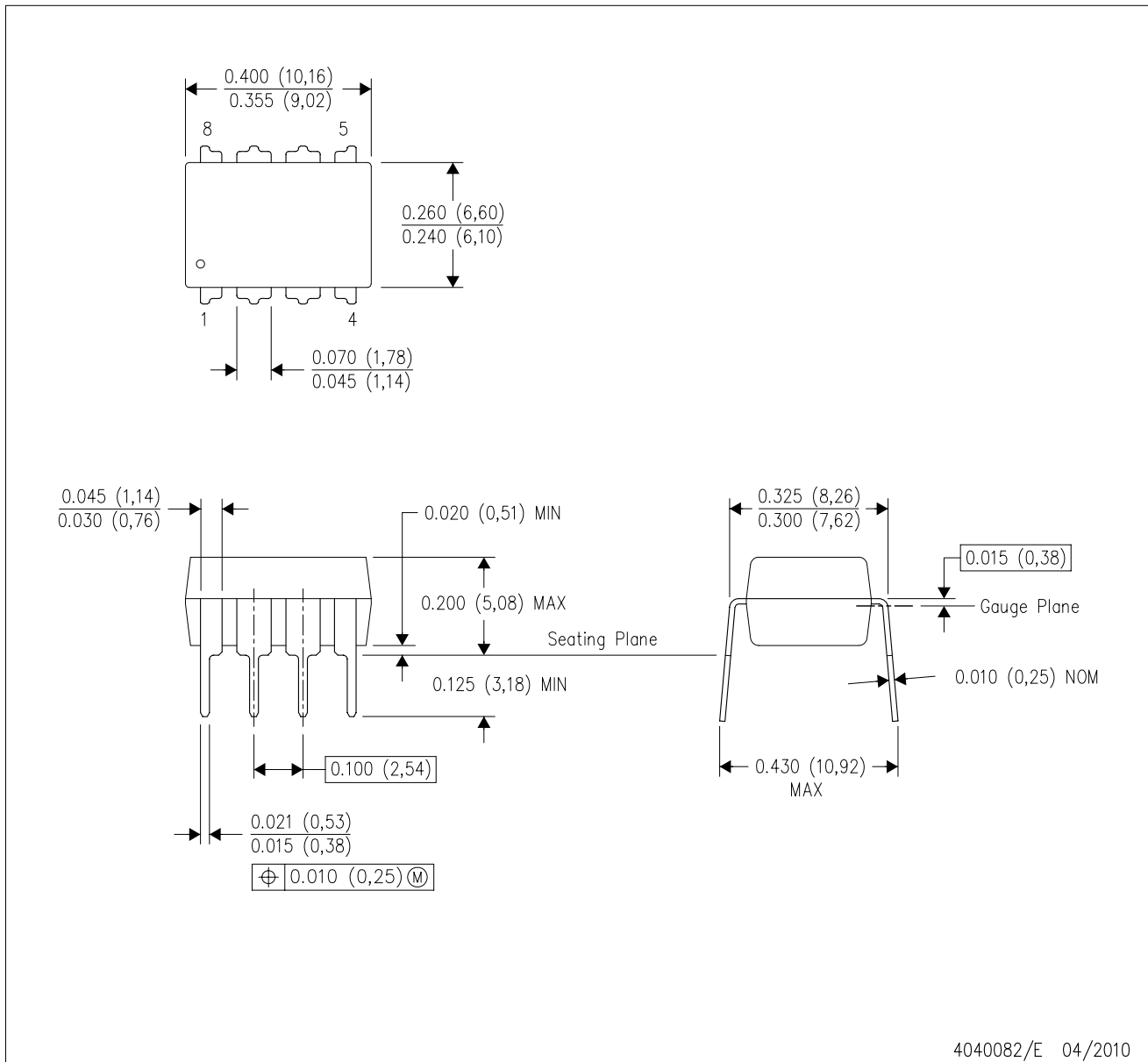

- NOTES:
- A. All linear dimensions are in inches (millimeters).
  - B. This drawing is subject to change without notice.
  - C. Falls within JEDEC MS-001 variation BA.

# DGK0008A



# PACKAGE OUTLINE

VSSOP - 1.1 mm max height

SMALL OUTLINE PACKAGE



**NOTES:**

PowerPAD is a trademark of Texas Instruments.

1. All linear dimensions are in millimeters. Any dimensions in parenthesis are for reference only. Dimensioning and tolerancing per ASME Y14.5M.
2. This drawing is subject to change without notice.
3. This dimension does not include mold flash, protrusions, or gate burrs. Mold flash, protrusions, or gate burrs shall not exceed 0.15 mm per side.
4. This dimension does not include interlead flash. Interlead flash shall not exceed 0.25 mm per side.
5. Reference JEDEC registration MO-187.

# EXAMPLE BOARD LAYOUT

DGK0008A

™ VSSOP - 1.1 mm max height

SMALL OUTLINE PACKAGE



LAND PATTERN EXAMPLE  
EXPOSED METAL SHOWN  
SCALE: 15X



SOLDER MASK DETAILS

4214862/A 04/2023

NOTES: (continued)

6. Publication IPC-7351 may have alternate designs.
7. Solder mask tolerances between and around signal pads can vary based on board fabrication site.
8. Vias are optional depending on application, refer to device data sheet. If any vias are implemented, refer to their locations shown on this view. It is recommended that vias under paste be filled, plugged or tented.
9. Size of metal pad may vary due to creepage requirement.

# EXAMPLE STENCIL DESIGN

DGK0008A

™ VSSOP - 1.1 mm max height

SMALL OUTLINE PACKAGE



SOLDER PASTE EXAMPLE  
SCALE: 15X

4214862/A 04/2023

NOTES: (continued)

11. Laser cutting apertures with trapezoidal walls and rounded corners may offer better paste release. IPC-7525 may have alternate design recommendations.
12. Board assembly site may have different recommendations for stencil design.

## IMPORTANT NOTICE AND DISCLAIMER

TI PROVIDES TECHNICAL AND RELIABILITY DATA (INCLUDING DATA SHEETS), DESIGN RESOURCES (INCLUDING REFERENCE DESIGNS), APPLICATION OR OTHER DESIGN ADVICE, WEB TOOLS, SAFETY INFORMATION, AND OTHER RESOURCES "AS IS" AND WITH ALL FAULTS, AND DISCLAIMS ALL WARRANTIES, EXPRESS AND IMPLIED, INCLUDING WITHOUT LIMITATION ANY IMPLIED WARRANTIES OF MERCHANTABILITY, FITNESS FOR A PARTICULAR PURPOSE OR NON-INFRINGEMENT OF THIRD PARTY INTELLECTUAL PROPERTY RIGHTS.

These resources are intended for skilled developers designing with TI products. You are solely responsible for (1) selecting the appropriate TI products for your application, (2) designing, validating and testing your application, and (3) ensuring your application meets applicable standards, and any other safety, security, regulatory or other requirements.

These resources are subject to change without notice. TI grants you permission to use these resources only for development of an application that uses the TI products described in the resource. Other reproduction and display of these resources is prohibited. No license is granted to any other TI intellectual property right or to any third party intellectual property right. TI disclaims responsibility for, and you will fully indemnify TI and its representatives against, any claims, damages, costs, losses, and liabilities arising out of your use of these resources.

TI's products are provided subject to [TI's Terms of Sale](#) or other applicable terms available either on [ti.com](https://www.ti.com) or provided in conjunction with such TI products. TI's provision of these resources does not expand or otherwise alter TI's applicable warranties or warranty disclaimers for TI products.

TI objects to and rejects any additional or different terms you may have proposed.

Mailing Address: Texas Instruments, Post Office Box 655303, Dallas, Texas 75265  
Copyright © 2024, Texas Instruments Incorporated

## Looking for pricing, stock, or lifecycle information?

Click below to explore more details on WIN SOURCE:

-  [View LM386N on WIN SOURCE](#)
-  [Texas Instruments](#) Information

## Optimize Your Supply Chain with WIN SOURCE Solutions

-  Global Sourcing Solution
-  Obsolete Management
-  Cost Control Management
-  Shortage Management
-  Alternative Solution
-  Excess Inventory Management