



**THE DATASHEET OF
LM3710XQMMX-308**



LM3710/LM3711 Microprocessor Supervisory Circuits with Power Fail Input, Low Line Output, Manual Reset and Watchdog Timer

 Check for Samples: [LM3710](#), [LM3711](#)

FEATURES

- **Standard Reset Threshold Voltage: 3.08V**
- **Custom Reset Threshold Voltages: For other voltages between 2.2V and 5.0V in 10mV increments, contact TI**
- **No External Components Required**
- **Manual-Reset Input**
- **$\overline{\text{RESET}}$ (LM3710) or $\overline{\text{RESET}}$ (LM3711) Outputs**
- **Precision Supply Voltage Monitor**
- **Factory Programmable Reset and Watchdog Timeout Delays**
- **Separate Power Fail Comparator**
- **Available in DSBGA Package for Minimum Footprint**
- **$\pm 0.5\%$ Reset Threshold Accuracy at Room Temperature**
- **$\pm 2\%$ Reset Threshold Accuracy Over Temperature Extremes**
- **Reset Assertion Down to 1V V_{CC} ($\overline{\text{RESET}}$ Option Only)**
- **28 μA V_{CC} Supply Current**

APPLICATIONS

- **Embedded Controllers and Processors**
- **Intelligent Instruments**
- **Automotive Systems**
- **Critical μP Power Monitoring**

Typical Application

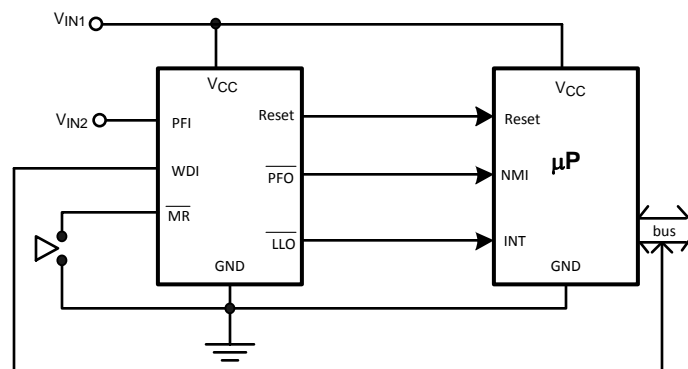

DESCRIPTION

The LM3710/LM3711 series of microprocessor supervisory circuits provide the maximum flexibility for monitoring power supplies and battery controlled functions in systems without backup batteries. The LM3710/LM3711 series are available in VSSOP-10 and 9-bump DSBGA packages.

Built-in features include the following:

Reset: Reset is asserted during power-up, power-down, and brownout conditions. $\overline{\text{RESET}}$ is ensured down to V_{CC} of 1.0V.

Manual Reset Input: An input that asserts reset when pulled low.

Power-Fail Input: A 1.225V threshold detector for power fail warning, or to monitor a power supply other than V_{CC} .

Low Line Output: This early power failure warning indicator goes low when the supply voltage drops to a value which is 2% higher than the reset threshold voltage.

Watchdog Timer: The WDI (Watchdog Input) monitors one of the μP 's output lines for activity. If no output transition occurs during the watchdog timeout period, reset is activated.



Please be aware that an important notice concerning availability, standard warranty, and use in critical applications of Texas Instruments semiconductor products and disclaimers thereto appears at the end of this data sheet.

All trademarks are the property of their respective owners.

Connection Diagram

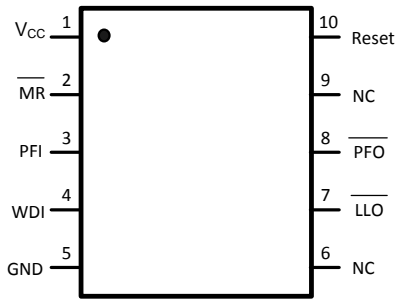

Figure 1. VSSOP-10

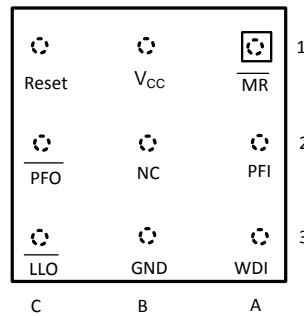

Figure 2. Top View (looking from the coating side) DSBGA 9 Bump Package

PIN DESCRIPTIONS

Pin No.		Name	Function
DSBGA	VSSOP		
A1	2	\overline{MR}	Manual-Reset input. When \overline{MR} is less than V_{MRT} (Manual Reset Threshold) $\overline{RESET}/RESET$ is engaged.
B1	1	V_{CC}	Power Supply input.
C1	10	\overline{RESET}	Reset Logic Output. Pulses low for t_{RP} (Reset Timeout Period) when triggered, and stays low whenever V_{CC} is below the reset threshold or when \overline{MR} is below V_{MRT} . It remains low for t_{RP} after either V_{CC} rises above the reset threshold, or after \overline{MR} input rises above V_{MRT} (LM3710 only).
		RESET	Reset Logic Output. RESET is the inverse of \overline{RESET} (LM3711 only).
C2	8	\overline{PFO}	Power-Fail Logic Output. When PFI is below V_{PFT} , \overline{PFO} goes low; otherwise, \overline{PFO} remains high.
C3	7	\overline{LLO}	Low-Line Logic Output. Early Power-Fail warning output. Low when V_{CC} falls below V_{LLOT} (Low-Line Output Threshold). This output can be used to generate an NMI (Non-Maskable Interrupt) to provide an early warning of imminent power-failure.
B3	5	GND	Ground reference for all signals.
A3	4	WDI	Watchdog Input Transition Monitor: If no transition activity occurs for a period exceeding t_{WD} (Watchdog Timeout Period), reset is engaged.
A2	3	PFI	Power-Fail Comparator Input. When PFI is less than V_{PFT} (Power-Fail Reset Threshold), the \overline{PFO} goes low; otherwise, \overline{PFO} remains high.
B2	6, 9	NC	No Connect. Test input used at factory only. Leave floating.

Block Diagram

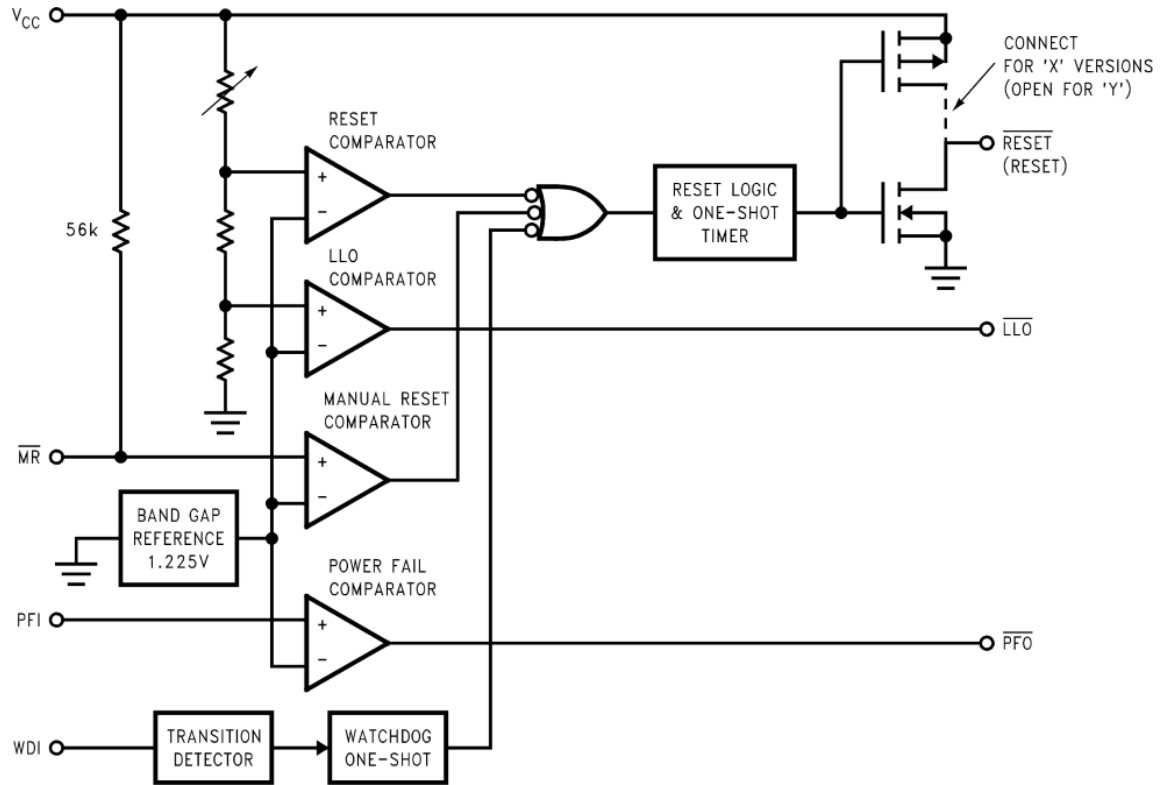

Table Of Functions

Part Number	Active Low Reset	Active High Reset	Output (X = totem-pole) (Y = open-drain)	Reset Timeout Period	Watchdog Timeout Period	Manual Reset	Power Fail Comparator	Low Line Output
LM3710	x		X, Y ⁽¹⁾	Customized	Customized	x	x	x
LM3711		x	X	Customized	Customized	x	x	x

(1) Available upon request. Contact TI.



These devices have limited built-in ESD protection. The leads should be shorted together or the device placed in conductive foam during storage or handling to prevent electrostatic damage to the MOS gates.

Absolute Maximum Ratings⁽¹⁾⁽²⁾

Supply Voltage (V_{CC})	-0.3V to 6.0V
All Other Inputs	-0.3V to $V_{CC} + 0.3V$
ESD Ratings ⁽³⁾	
Human Body Model	1.5kV
Machine Model	150V
Power Dissipation	⁽⁴⁾

- (1) **Absolute Maximum Ratings** indicate limits beyond which damage to the device may occur. **Operating Ratings** indicate conditions for which the device is intended to be functional, but do not ensure specific performance limits. For ensured specifications and test conditions, see the Electrical Characteristics. The ensured specifications apply only for the test conditions listed. Some performance characteristics may degrade when the device is not operated under the listed conditions.
- (2) If Military/Aerospace specified devices are required, please contact the Texas Instruments Sales Office/Distributors for availability and specifications.
- (3) The Human Body model is a 100 pF capacitor discharged through a 1.5 k Ω resistor into each pin. The machine model is a 200pF capacitor discharged directly into each pin.
- (4) The maximum allowable power dissipation is a function of the maximum junction temperature, $T_J(\text{MAX})$, the junction-to-ambient thermal resistance, θ_{J-A} , and the ambient temperature, T_A . The maximum allowable power dissipation at any ambient temperature is calculated using:

$$P(\text{MAX}) = \frac{T_J(\text{MAX}) - T_A}{\theta_{J-A}}$$

Where the value of θ_{J-A} for the VSSOP-10 package is 195°C/W in a typical PC board mounting and the DSBGA package is 220°C/W.

Operating Ratings⁽¹⁾

Temperature Range	$-40^\circ\text{C} \leq T_J \leq 85^\circ\text{C}$
-------------------	--

- (1) **Absolute Maximum Ratings** indicate limits beyond which damage to the device may occur. **Operating Ratings** indicate conditions for which the device is intended to be functional, but do not ensure specific performance limits. For ensured specifications and test conditions, see the Electrical Characteristics. The ensured specifications apply only for the test conditions listed. Some performance characteristics may degrade when the device is not operated under the listed conditions.

LM3710/LM3711 Series Electrical Characteristics

Limits in the standard typeface are for $T_J = 25^\circ\text{C}$ and limits in **boldface type** apply over full operating range. Unless otherwise specified: $V_{CC} = +2.2V$ to 5.5V.

Symbol	Parameter	Conditions	Min	Typ	Max	Units
POWER SUPPLY						
V_{CC}	Operating Voltage Range: V_{CC}	LM3710	1.0		5.5	V
		LM3711	1.2		5.5	
I_{CC}	V_{CC} Supply Current	All inputs = V_{CC} ; all outputs floating		28	50	μA
RESET THRESHOLD						
V_{RST}	Reset Threshold	V_{CC} falling	-0.5 -2	V_{RST}	+0.5 +2	%
		V_{CC} falling: $T_A = 0^\circ\text{C}$ to 70°C	-1.5		+1.5	
V_{RSTH}	Reset Threshold Hysteresis			$0.0032 \cdot V_{RST}$		mV
t_{RP}	Reset Timeout Period	Reset Timeout Period = E, J, N, S	1	1.4	2	ms
		Reset Timeout Period = F, K, P, T	20	28	40	
		Reset Timeout Period = G, L, Q, U	140	200	280	
		Reset Timeout Period = H, M, R, V	1120	1600	2240	
t_{RD}	V_{CC} to Reset Delay	V_{CC} falling at 1mV/ μs		20		μs
RESET (LM3711)						
V_{OL}	RESET	$V_{CC} > 2.25V$, $I_{SINK} = 900\mu\text{A}$			0.3	V
		$V_{CC} > 2.7V$, $I_{SINK} = 1.2\text{mA}$			0.3	
		$V_{CC} > 4.5V$, $I_{SINK} = 3.2\text{mA}$			0.4	
V_{OH}	RESET	$V_{CC} > 1.2V$, $I_{SOURCE} = 50\mu\text{A}$	0.8 V_{CC}			V
		$V_{CC} > 1.8V$, $I_{SOURCE} = 150\mu\text{A}$	0.8 V_{CC}			
		$V_{CC} > 2.25V$, $I_{SOURCE} = 300\mu\text{A}$	0.8 V_{CC}			
		$V_{CC} > 2.7V$, $I_{SOURCE} = 500\mu\text{A}$	0.8 V_{CC}			
		$V_{CC} > 4.5V$, $I_{SOURCE} = 800\mu\text{A}$	$V_{CC} - 1.5V$			

LM3710/LM3711 Series Electrical Characteristics (continued)

 Limits in the standard typeface are for $T_J = 25^\circ\text{C}$ and limits in **boldface type** apply over full operating range. Unless otherwise specified: $V_{CC} = +2.2\text{V}$ to 5.5V .

Symbol	Parameter	Conditions	Min	Typ	Max	Units
I_{LKG}	Output Leakage Current	$V_{RESET} = 5.5\text{V}$			1.0	μA
RESET (LM3710)						
V_{OL}	RESET	$V_{CC} > 1.0\text{V}$, $I_{SINK} = 50\mu\text{A}$			0.3	V
		$V_{CC} > 1.2\text{V}$, $I_{SINK} = 100\mu\text{A}$			0.3	
		$V_{CC} > 2.25\text{V}$, $I_{SINK} = 900\mu\text{A}$			0.3	
		$V_{CC} > 2.7\text{V}$, $I_{SINK} = 1.2\text{mA}$			0.3	
		$V_{CC} > 4.5\text{V}$, $I_{SINK} = 3.2\text{mA}$			0.4	
V_{OH}	RESET	$V_{CC} > 2.25\text{V}$, $I_{SOURCE} = 300\mu\text{A}$	$0.8 V_{CC}$			
		$V_{CC} > 2.7\text{V}$, $I_{SOURCE} = 500\mu\text{A}$	$0.8 V_{CC}$			
		$V_{CC} > 4.5\text{V}$, $I_{SOURCE} = 800\mu\text{A}$	$V_{CC} - 1.5\text{V}$			
WDI						
WDI	Watchdog Input Current		-1		+1	μA
WDI_T	Watchdog Input Threshold		$0.2 \cdot V_{CC}$	1.225	$0.8 \cdot V_{CC}$	V
t_{WD}	Watchdog Timeout Period	Watchdog Timeout Period = E, F, G, H Watchdog Timeout Period = J, K, L, M Watchdog Timeout Period = N, P, Q, R Watchdog Timeout Period = S, T, U, V	4.3 71 1120 17900	6.2 102 1600 25600	9.3 153 2400 38400	ms
PFI/MR						
V_{PFT}	PFI Input Threshold		1.200	1.225	1.250	V
V_{MRT}	MR Input Threshold	MR, Low			0.8	V
		MR, High	2.0			
$V_{PFTH}/V_{MRT H}$	PFI/MR Threshold Hysteresis	PFI/MR falling: $V_{CC} = V_{RST\ MAX}$ to 5.5V		$0.0032 \cdot V_{RST}$		mV
I_{PFI}	Input Current (PFI only)		-75		75	nA
R_{MR}	MR Pull-up Resistance		35	56	75	k Ω
t_{MD}	MR to Reset Delay			12		μs
t_{MR}	MR Pulse Width		25			μs
PFO, LLO						
V_{OL}	PFO, LLO Output Voltage	$V_{CC} > 2.25\text{V}$, $I_{SINK} = 900\mu\text{A}$			0.3	V
		$V_{CC} > 2.7\text{V}$, $I_{SINK} = 1.2\text{mA}$			0.3	
		$V_{CC} > 4.5\text{V}$, $I_{SINK} = 3.2\text{mA}$			0.4	
V_{OH}		$V_{CC} > 2.25\text{V}$, $I_{SOURCE} = 300\mu\text{A}$	$0.8 V_{CC}$			
		$V_{CC} > 2.7\text{V}$, $I_{SOURCE} = 500\mu\text{A}$	$0.8 V_{CC}$			
		$V_{CC} > 4.5\text{V}$, $I_{SOURCE} = 800\mu\text{A}$	$V_{CC} - 1.5\text{V}$			
LLO OUTPUT						
V_{LLOT}	LLO Output Threshold ($V_{LLO} - V_{RST}$, V_{CC} falling)		$1.01 \cdot V_{RST}$	$1.02 \cdot V_{RST}$	$1.03 \cdot V_{RST}$	V
V_{LLOTH}	Low-Line Comparator Hysteresis			$0.0032 \cdot V_{RST}$		mV
t_{CD}	Low-Line Comparator Delay	V_{CC} falling at $1\text{mV}/\mu\text{s}$		20		μs

Typical Performance Characteristics

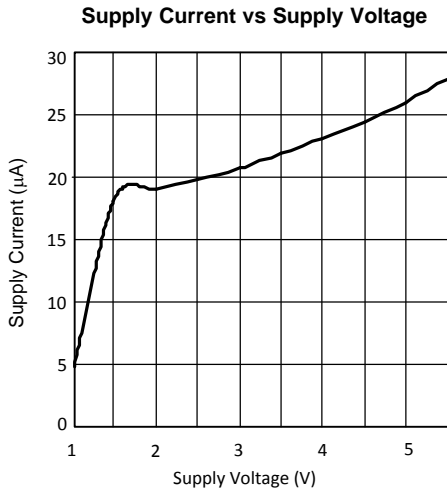

Figure 3.

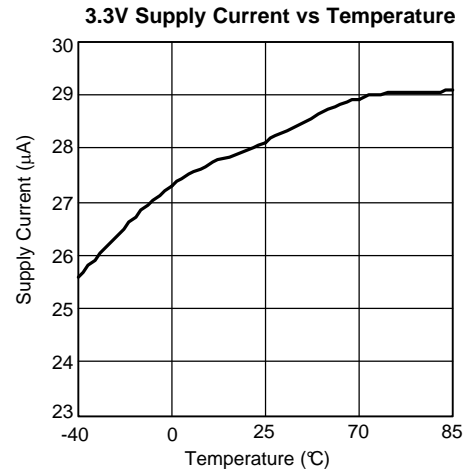

Figure 4.

Normalized Reset Threshold Voltage vs Temperature

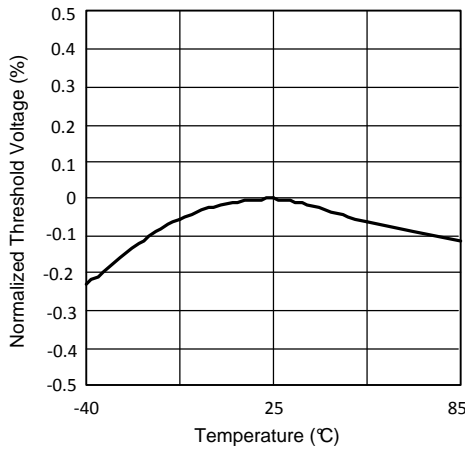

Figure 5.

Reset Timeout Period vs V_{CC}

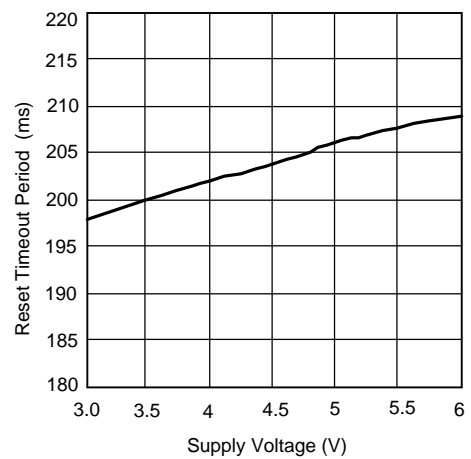

Figure 6.

Reset Timeout Period vs Temperature

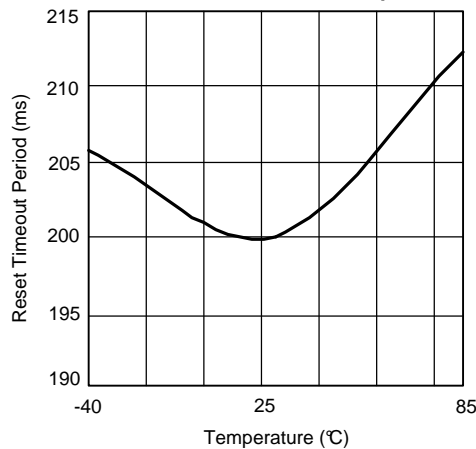

Figure 7.

Max. Transient Duration vs Reset Comparator Overdrive (V_{CC} = 3.3V)

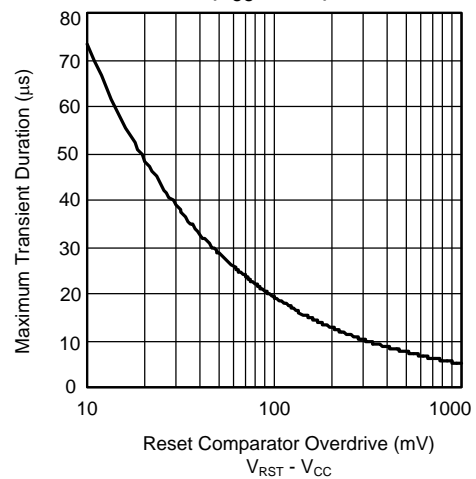

Figure 8.

Typical Performance Characteristics (continued)

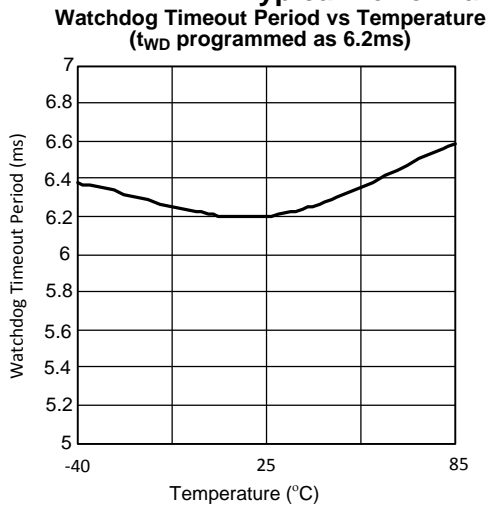

Figure 9.

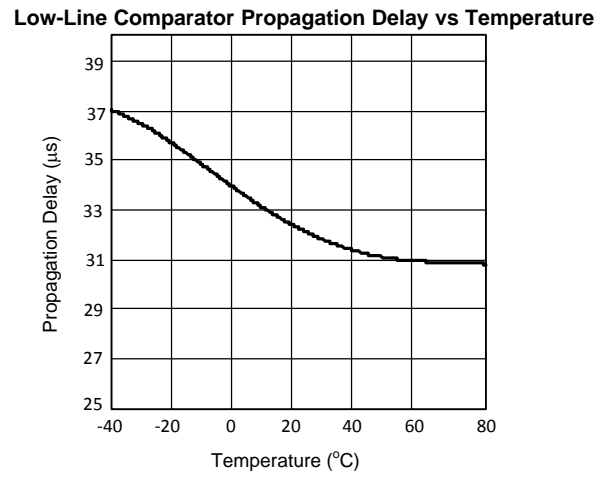

Figure 10.

CIRCUIT INFORMATION

RESET OUTPUT

The Reset input of a μP initializes the device into a known state. The LM3710/LM3711 microprocessor supervisory circuits assert a forced reset output to prevent code execution errors during power-up, power-down, and brownout conditions.

$\overline{\text{RESET}}$ is ensured valid for $V_{\text{CC}} > 1\text{V}$. Once V_{CC} exceeds the reset threshold, an internal timer maintains the output for the reset timeout period. After this interval, reset goes high. The LM3710 offers an active-low $\overline{\text{RESET}}$; The LM3711 offers an active-high RESET.

Any time V_{CC} drops below the reset threshold (such as during a brownout), the reset activates. When V_{CC} again rises above the reset threshold, the internal timer starts. Reset holds until V_{CC} exceeds the reset threshold for longer than the reset timeout period. After this time, reset releases.

The Manual Reset input ($\overline{\text{MR}}$) will initiate a forced reset also. See the [MANUAL RESET INPUT \(\$\overline{\text{MR}}\$ \)](#) section.

RESET THRESHOLD

The LM3710/LM3711 family is available with a reset voltage of 3.08V. Other reset thresholds in the 2.20V to 5.0V range, in steps of 10 mV, are available; contact Texas Instruments for details.

MANUAL RESET INPUT ($\overline{\text{MR}}$)

Many μP -based products require a manual reset capability, allowing the operator to initiate a reset. The $\overline{\text{MR}}$ input is fully debounced and provides an internal 56 k Ω pull-up. When the $\overline{\text{MR}}$ input is pulled below V_{MRT} (1.225V) for more than 25 μs , reset is asserted after a typical delay of 12 μs . Reset remains active as long as $\overline{\text{MR}}$ is held low, and releases after the reset timeout period expires after $\overline{\text{MR}}$ rises above V_{MRT} . Use $\overline{\text{MR}}$ with digital logic to assert or to daisy chain supervisory circuits. It may be used as another low-line comparator by adding a buffer.

POWER-FAIL COMPARATOR (PFI/ $\overline{\text{PFO}}$)

The PFI is compared to a 1.225V internal reference, V_{PFT} . If PFI is less than V_{PFT} , the Power Fail Output $\overline{\text{PFO}}$ drops low. The power-fail comparator signals a falling power supply, and is driven typically by an external voltage divider that senses either the unregulated supply or another system supply voltage. The voltage divider generally is chosen so the voltage at PFI drops below V_{PFT} several milliseconds before the main supply voltage drops below the reset threshold, providing advanced warning of a brownout.

The voltage threshold is set by R_1 and R_2 and is calculated as follows:

$$V_{\text{PFT}} = \left(\frac{R_1 + R_2}{R_2} \right) \times 1.225\text{V} \quad (1)$$

Note this comparator is completely separate from the rest of the circuitry, and may be employed for other functions as needed.

LOW-LINE OUTPUT ($\overline{\text{LLO}}$)

The low-line output comparator is typically used to provide a non-maskable interrupt to a μP when V_{CC} begins falling. $\overline{\text{LLO}}$ monitors V_{CC} and goes low when V_{CC} falls below V_{LLOT} (typically $1.02 \cdot V_{\text{RST}}$) with hysteresis of $0.0032 \cdot V_{\text{RST}}$.

WATCHDOG TIMER INPUT (WDI)

The watchdog timer input monitors one of the microprocessor's output lines for activity. Each time a transition occurs on this monitored line, the watchdog counter is reset. However, if no transition occurs and the timeout period is reached, the LM3710/LM3711 assumes that the microprocessor has locked up and the reset output is activated.

WDI is a high impedance input.

SPECIAL PRECAUTIONS FOR THE DSBGA PACKAGE

As with most integrated circuits, the LM3710 and LM3711 are sensitive to exposure from visible and infrared (IR) light radiation. Unlike a plastic encapsulated IC, the DSBGA package has very limited shielding from light, and some sensitivity to light reflected from the surface of the PC board or long wavelength IR entering the die from the side may be experienced. This light could have an unpredictable affect on the electrical performance of the IC. Care should be taken to shield the device from direct exposure to bright visible or IR light during operation.

DSBGA MOUNTING

The DSBGA package requires specific mounting techniques which are detailed in TI Application Note AN-1112 (SNVA009). Referring to the section **Surface Mount Assembly Considerations**, it should be noted that the pad style which must be used with the 9-pin package is the NSMD (non-solder mask defined) type.

For best results during assembly, alignment ordinals on the PC board may be used to facilitate placement of the DSBGA device.

Timing Diagrams

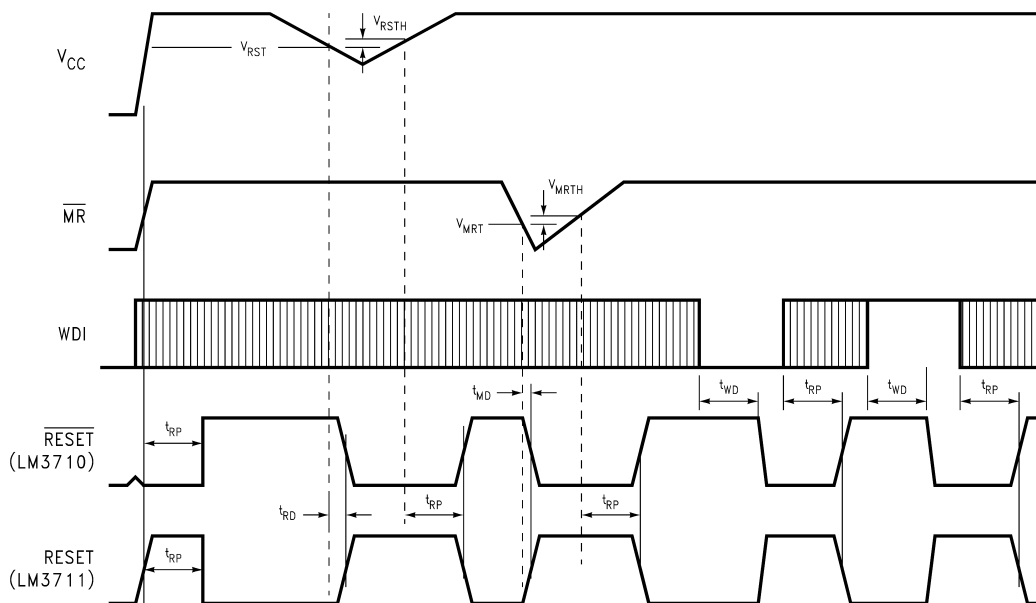

Figure 11. LM3710/LM3711 Reset Time with \overline{MR} and WDI

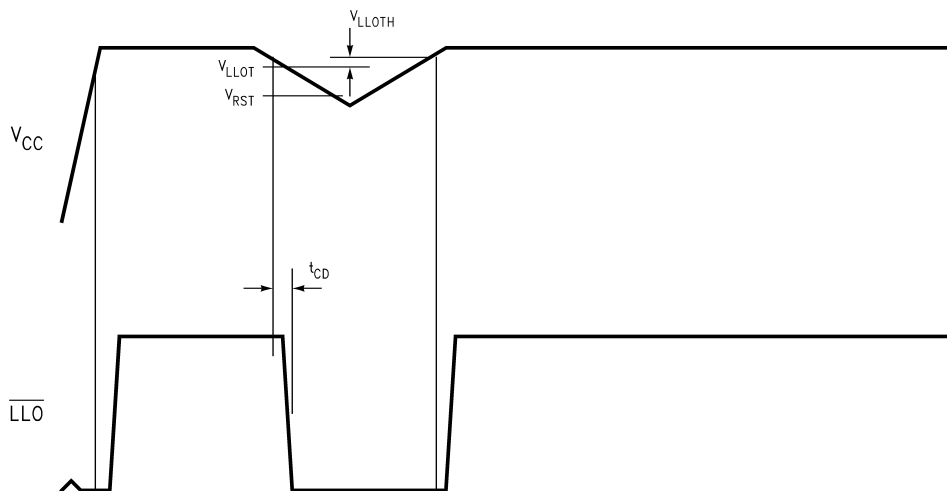

Figure 12. \overline{LLO} Output

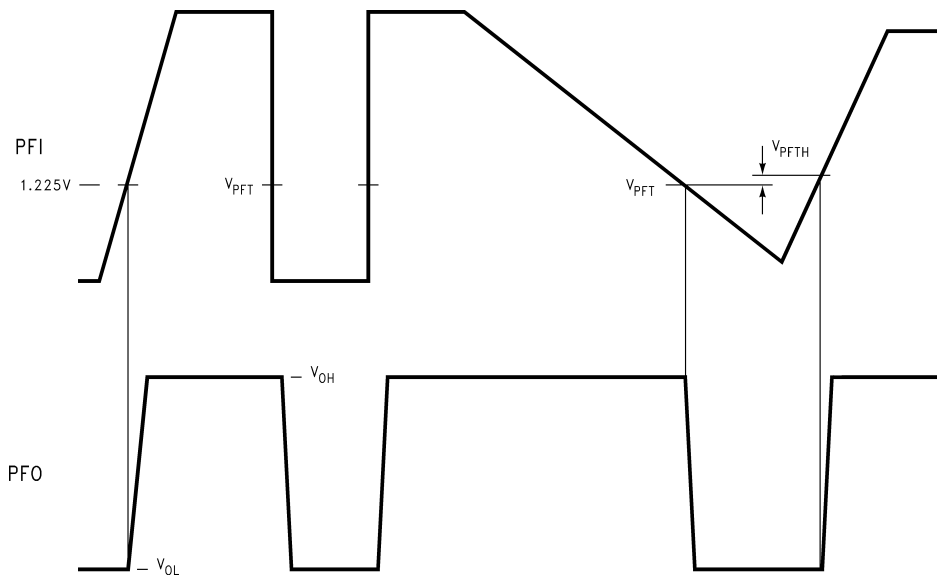

Figure 13. PFI Comparator Timing Diagram

Typical Application Circuits

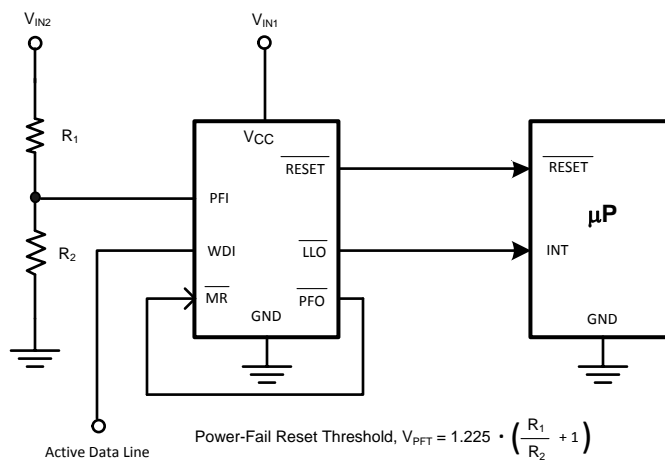

Figure 14. Monitoring Two Critical Supplies And Dataline

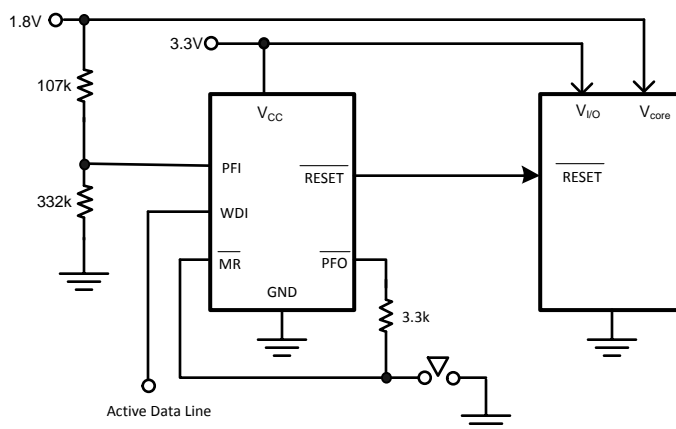

Figure 15. Monitoring Two Supplies plus Manual Reset And Dataline

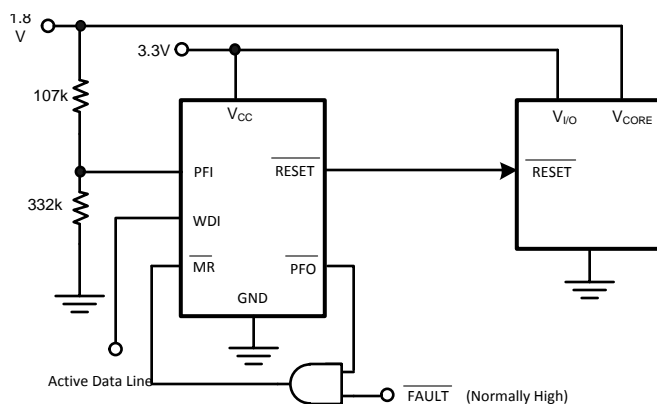
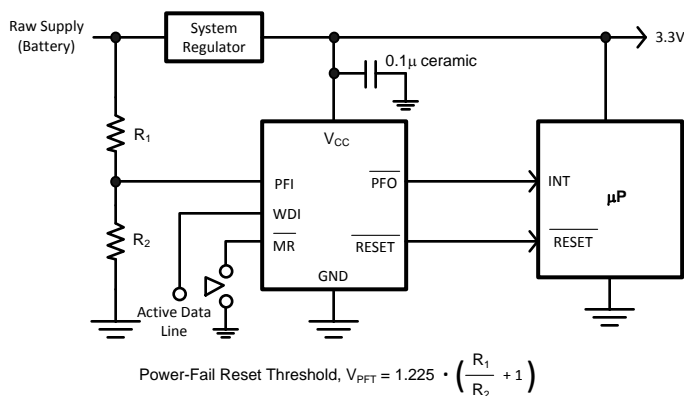

Figure 16. Monitoring Dual Supplies plus External Fault Input And Dataline



Note: \overline{MR} input with its 1.225V nominal threshold, may monitor an additional supply voltage. An internal 56 kΩ pull-up resistor is included on this input.

Figure 17. Microprocessor Supervisor with Early Warning Detector

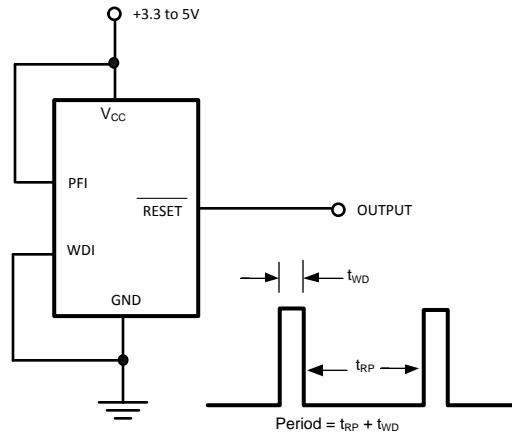

Figure 18. LM3710 Long Period oscillator

REVISION HISTORY

Changes from Revision D (March 2013) to Revision E	Page
• Changed layout of National Data Sheet to TI format	12

PACKAGING INFORMATION

Orderable Device	Status (1)	Package Type	Package Drawing	Pins	Package Qty	Eco Plan (2)	Lead/Ball Finish (6)	MSL Peak Temp (3)	Op Temp (°C)	Device Marking (4/5)	Samples
LM3710XKMM-463/NOPB	ACTIVE	VSSOP	DGS	10	1000	Green (RoHS & no Sb/Br)	CU SN	Level-1-260C-UNLIM		R74B	Samples
LM3710XQMM-308/NOPB	ACTIVE	VSSOP	DGS	10	1000	Green (RoHS & no Sb/Br)	CU SN	Level-1-260C-UNLIM	-40 to 85	R37B	Samples
LM3710YQMM-232/NOPB	ACTIVE	VSSOP	DGS	10	1000	Green (RoHS & no Sb/Br)	CU SN	Level-1-260C-UNLIM		R77B	Samples

(1) The marketing status values are defined as follows:

ACTIVE: Product device recommended for new designs.

LIFEBUY: TI has announced that the device will be discontinued, and a lifetime-buy period is in effect.

NRND: Not recommended for new designs. Device is in production to support existing customers, but TI does not recommend using this part in a new design.

PREVIEW: Device has been announced but is not in production. Samples may or may not be available.

OBSOLETE: TI has discontinued the production of the device.

(2) Eco Plan - The planned eco-friendly classification: Pb-Free (RoHS), Pb-Free (RoHS Exempt), or Green (RoHS & no Sb/Br) - please check <http://www.ti.com/productcontent> for the latest availability information and additional product content details.

TBD: The Pb-Free/Green conversion plan has not been defined.

Pb-Free (RoHS): TI's terms "Lead-Free" or "Pb-Free" mean semiconductor products that are compatible with the current RoHS requirements for all 6 substances, including the requirement that lead not exceed 0.1% by weight in homogeneous materials. Where designed to be soldered at high temperatures, TI Pb-Free products are suitable for use in specified lead-free processes.

Pb-Free (RoHS Exempt): This component has a RoHS exemption for either 1) lead-based flip-chip solder bumps used between the die and package, or 2) lead-based die adhesive used between the die and leadframe. The component is otherwise considered Pb-Free (RoHS compatible) as defined above.

Green (RoHS & no Sb/Br): TI defines "Green" to mean Pb-Free (RoHS compatible), and free of Bromine (Br) and Antimony (Sb) based flame retardants (Br or Sb do not exceed 0.1% by weight in homogeneous material)

(3) MSL, Peak Temp. - The Moisture Sensitivity Level rating according to the JEDEC industry standard classifications, and peak solder temperature.

(4) There may be additional marking, which relates to the logo, the lot trace code information, or the environmental category on the device.

(5) Multiple Device Markings will be inside parentheses. Only one Device Marking contained in parentheses and separated by a "~" will appear on a device. If a line is indented then it is a continuation of the previous line and the two combined represent the entire Device Marking for that device.

(6) Lead/Ball Finish - Orderable Devices may have multiple material finish options. Finish options are separated by a vertical ruled line. Lead/Ball Finish values may wrap to two lines if the finish value exceeds the maximum column width.

Important Information and Disclaimer: The information provided on this page represents TI's knowledge and belief as of the date that it is provided. TI bases its knowledge and belief on information provided by third parties, and makes no representation or warranty as to the accuracy of such information. Efforts are underway to better integrate information from third parties. TI has taken and

continues to take reasonable steps to provide representative and accurate information but may not have conducted destructive testing or chemical analysis on incoming materials and chemicals. TI and TI suppliers consider certain information to be proprietary, and thus CAS numbers and other limited information may not be available for release.

In no event shall TI's liability arising out of such information exceed the total purchase price of the TI part(s) at issue in this document sold by TI to Customer on an annual basis.

TAPE AND REEL INFORMATION

QUADRANT ASSIGNMENTS FOR PIN 1 ORIENTATION IN TAPE

*All dimensions are nominal

Device	Package Type	Package Drawing	Pins	SPQ	Reel Diameter (mm)	Reel Width W1 (mm)	A0 (mm)	B0 (mm)	K0 (mm)	P1 (mm)	W (mm)	Pin1 Quadrant
LM3710XKMM-463/NOPB	VSSOP	DGS	10	1000	178.0	12.4	5.3	3.4	1.4	8.0	12.0	Q1
LM3710XQMM-308/NOPB	VSSOP	DGS	10	1000	178.0	12.4	5.3	3.4	1.4	8.0	12.0	Q1
LM3710YQMM-232/NOPB	VSSOP	DGS	10	1000	178.0	12.4	5.3	3.4	1.4	8.0	12.0	Q1

TAPE AND REEL BOX DIMENSIONS

*All dimensions are nominal

Device	Package Type	Package Drawing	Pins	SPQ	Length (mm)	Width (mm)	Height (mm)
LM3710XKMM-463/NOPB	VSSOP	DGS	10	1000	210.0	185.0	35.0
LM3710XQMM-308/NOPB	VSSOP	DGS	10	1000	210.0	185.0	35.0
LM3710YQMM-232/NOPB	VSSOP	DGS	10	1000	210.0	185.0	35.0

DGS0010A

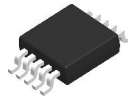

PACKAGE OUTLINE

VSSOP - 1.1 mm max height

SMALL OUTLINE PACKAGE

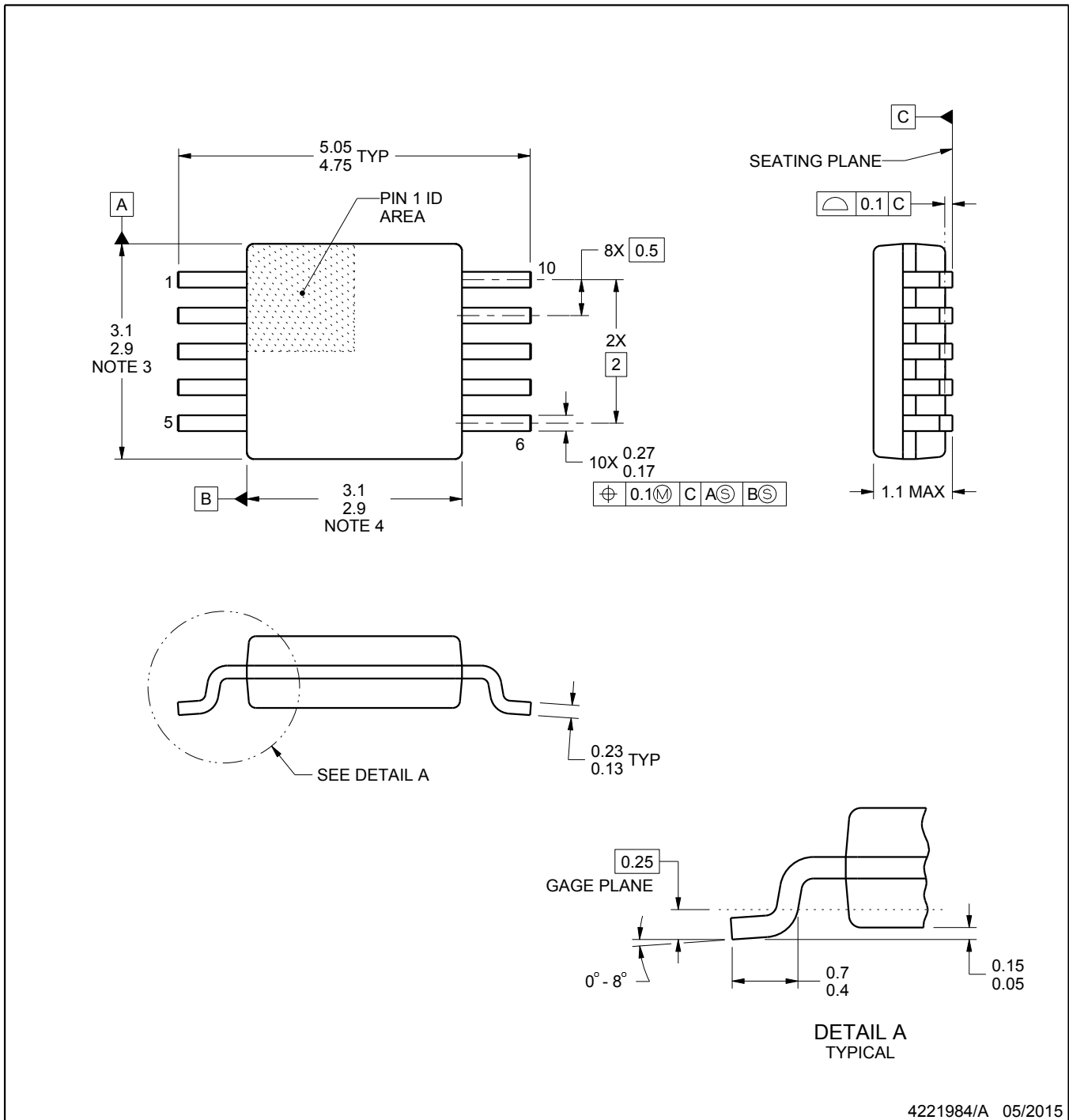

4221984/A 05/2015

NOTES:

1. All linear dimensions are in millimeters. Any dimensions in parenthesis are for reference only. Dimensioning and tolerancing per ASME Y14.5M.
2. This drawing is subject to change without notice.
3. This dimension does not include mold flash, protrusions, or gate burrs. Mold flash, protrusions, or gate burrs shall not exceed 0.15 mm per side.
4. This dimension does not include interlead flash. Interlead flash shall not exceed 0.25 mm per side.
5. Reference JEDEC registration MO-187, variation BA.

EXAMPLE BOARD LAYOUT

DGS0010A

VSSOP - 1.1 mm max height

SMALL OUTLINE PACKAGE

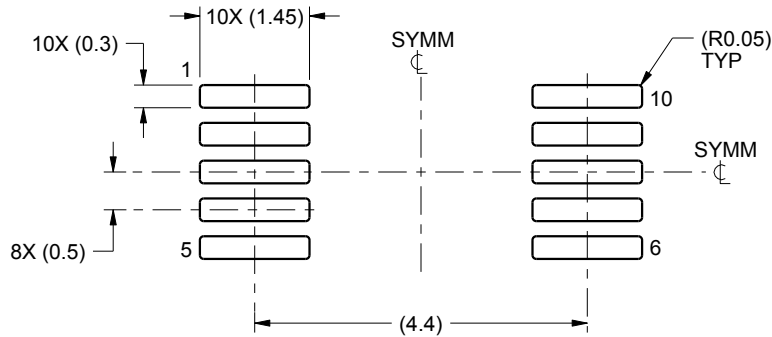

LAND PATTERN EXAMPLE
SCALE:10X



SOLDER MASK DETAILS
NOT TO SCALE

4221984/A 05/2015

NOTES: (continued)

- 6. Publication IPC-7351 may have alternate designs.
- 7. Solder mask tolerances between and around signal pads can vary based on board fabrication site.

EXAMPLE STENCIL DESIGN

DGS0010A

VSSOP - 1.1 mm max height

SMALL OUTLINE PACKAGE

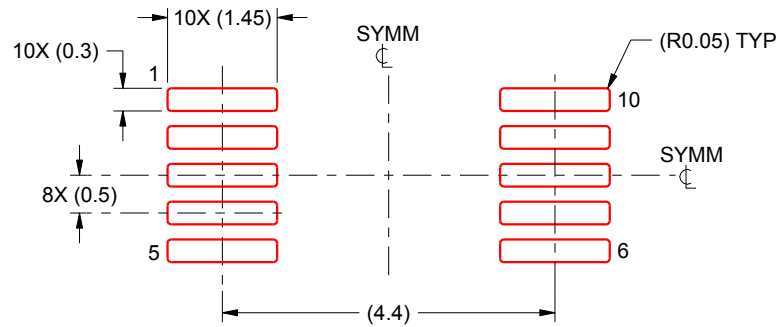

SOLDER PASTE EXAMPLE
BASED ON 0.125 mm THICK STENCIL
SCALE:10X

4221984/A 05/2015

NOTES: (continued)

8. Laser cutting apertures with trapezoidal walls and rounded corners may offer better paste release. IPC-7525 may have alternate design recommendations.
9. Board assembly site may have different recommendations for stencil design.

IMPORTANT NOTICE AND DISCLAIMER

TI PROVIDES TECHNICAL AND RELIABILITY DATA (INCLUDING DATASHEETS), DESIGN RESOURCES (INCLUDING REFERENCE DESIGNS), APPLICATION OR OTHER DESIGN ADVICE, WEB TOOLS, SAFETY INFORMATION, AND OTHER RESOURCES "AS IS" AND WITH ALL FAULTS, AND DISCLAIMS ALL WARRANTIES, EXPRESS AND IMPLIED, INCLUDING WITHOUT LIMITATION ANY IMPLIED WARRANTIES OF MERCHANTABILITY, FITNESS FOR A PARTICULAR PURPOSE OR NON-INFRINGEMENT OF THIRD PARTY INTELLECTUAL PROPERTY RIGHTS.

These resources are intended for skilled developers designing with TI products. You are solely responsible for (1) selecting the appropriate TI products for your application, (2) designing, validating and testing your application, and (3) ensuring your application meets applicable standards, and any other safety, security, or other requirements. These resources are subject to change without notice. TI grants you permission to use these resources only for development of an application that uses the TI products described in the resource. Other reproduction and display of these resources is prohibited. No license is granted to any other TI intellectual property right or to any third party intellectual property right. TI disclaims responsibility for, and you will fully indemnify TI and its representatives against, any claims, damages, costs, losses, and liabilities arising out of your use of these resources.

TI's products are provided subject to TI's Terms of Sale (www.ti.com/legal/termsofsale.html) or other applicable terms available either on ti.com or provided in conjunction with such TI products. TI's provision of these resources does not expand or otherwise alter TI's applicable warranties or warranty disclaimers for TI products.

Mailing Address: Texas Instruments, Post Office Box 655303, Dallas, Texas 75265
Copyright © 2018, Texas Instruments Incorporated

Looking for pricing, stock, or lifecycle information?

Click below to explore more details on WIN SOURCE:

- ⊖ [View LM3710XQMMX-308](#) on WIN SOURCE
- ⊖ [Texas Instruments](#) Information

Optimize Your Supply Chain with WIN SOURCE Solutions

- ✓ Global Sourcing Solution
- ✓ Obsolete Management
- ✓ Cost Control Management
- ✓ Shortage Management
- ✓ Alternative Solution
- ✓ Excess Inventory Management